

HOME GUARARAPES

V-7 08/08/23

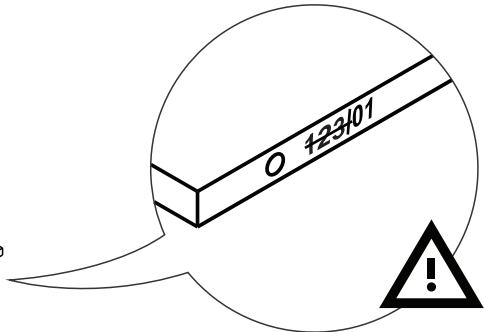
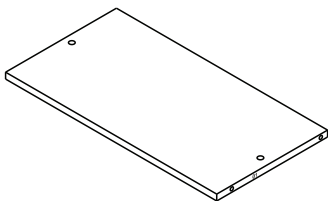
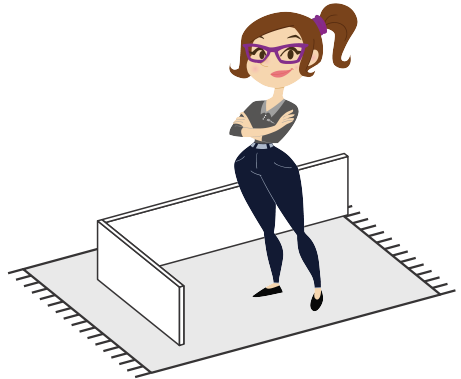
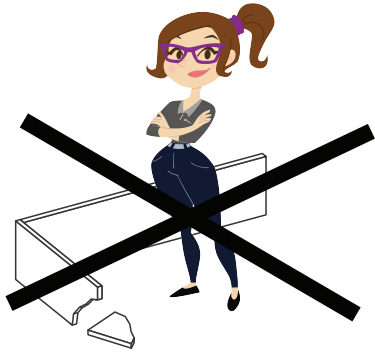
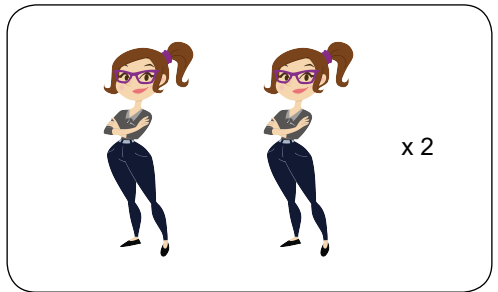
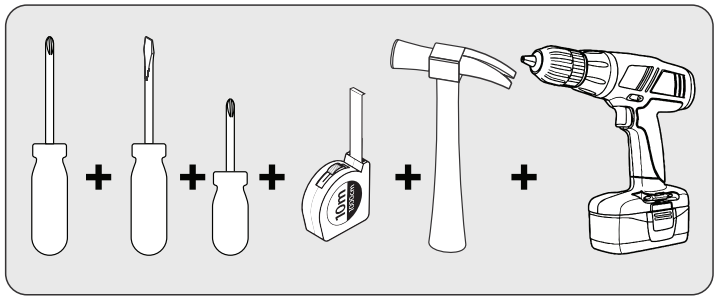
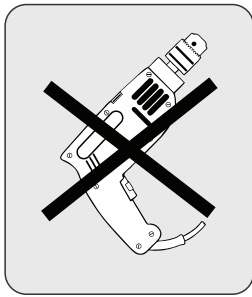

GARANTIA / GARANTIA / WARRANTY

Nossos produtos são garantidos por 90 dias contra defeitos de fabricação. Ao constatar um problema coberto pela garantia, entre em contato com a loja onde o produto foi comprado. Ela estará capacitada para atendê-lo da melhor forma diante de cada caso. Reclamações de garantia somente poderão ser atendidas se o termo de garantia for apresentado no ato de reivindicação, acompanhado de sua nota fiscal de compra.

Nuestros productos están garantidos contra defectos de fabricación por 90 días, a partir de la compra. Ao constatar un problema protegido por la garantía, póngase en contacto con la tienda donde se adquirió el producto. Ella estará capacitada para atenderlo de la mejor manera de acuerdo con cada caso.

Our products are guaranteed against manufacturing defects for 90 days from the date of purchase. When you find a problem covered by the warranty, please contact the store where the product was purchased. The store be able to serve you in the best way in each case.

Exclusões

- Desgaste natural ou danos causados por água, maresia, ferrugem, incêndio, calor, cupins e pragas em geral.
- Montagem, manutenção e uso inadequado.
- Não cumprimento das recomendações técnicas do esquema.
- Montagens e desmontagens após a primeira instalação.
- Instalações elétricas e outras afins.

Exclusiones

- *Desgaste natural o daños causados por agua, mares, maresia, incendios, calor, termitas y plagas en general.*
- *Montaje, mantenimiento y uso inadecuado.*
- *No cumplimiento de las recomendaciones técnicas del esquema.*
- *Montaje y desmontaje después de la primera instalación.*
- *Instalaciones eléctricas y otras afines.*

Exclusions

- *Natural wear or damage caused by water, sea, rust, fire, heat, termites and plagues in general.*
- *Assembly, maintenance and improper use.*
- *Failure to comply with the technical recommendations of the assembly instructions.*
- *Assembly and disassembly after first installation.*

Importante

A Linea Brasil não autoriza nenhuma pessoa, loja ou entidade assumir em seu nome qualquer outra garantia que não conste no certificado. A fabricante reserva-se no direito de efetuar nos produtos eventuais modificações que considerar necessárias, sem prejudicar as características essenciais. Os produtos terão peças de assistência para reposição no período de 1 ano a contar de sua retirada do mercado, desde que haja matéria-prima equivalente, observando o dispositivo no Art.32 da Lei 8.078/90 (Cód. Defesa do Consumidor). O atendimento para produtos fora de linha é feito por programação especial, através da loja revendedora sob aprovação de consulta prévia ao fabricante.

Importante

Linea Brasil no autoriza a ninguna persona, tienda o entidad a asumir en su nombre cualquier otra garantía que no figure en el certificado. El fabricante se reserva el derecho de efectuar en los productos eventuales modificaciones que considere necesarias, sin perjudicar las características esenciales. Los productos tendrán piezas de asistencia para reposición en el período de 1 año a partir de su retirada del mercado. La atención para productos fuera de línea es hecha por programación especial, a través de la tienda revendedora bajo aprobación de consulta previa al fabricante.

Important

Linea Brasil does not authorize any person, store or entity to assume on its behalf any other warranty that does not appear on the certificate. The manufacturer reserves the right to make in the products any modifications that it considers necessary without prejudice to the essential characteristics. The products will have replacement parts within one year of being withdrawn from the market. The service for off-line products is done by special programming, through the store reseller under prior consultation with the manufacturer.

INSTRUÇÕES DE LIMPEZA E CONSERVAÇÃO

INSTRUCCIONES PARA LA LIMPIEZA E CONSERVACION / CLEAN AND PRESERVATION INSTRUCTURE

Para retirar o pó, utilize um pano seco, espanador ou aspirador. Se necessário, para uma limpeza mais efetiva, utilize um pano levemente umedecido com água. Finalize com uma flanela limpa e seca.

Para eliminar el polvo, utilice un paño seco, mopa o la aspiradora. Si es necesario, para una limpieza más eficaz, utilice un paño ligeramente humedecido con agua. Terminar con un paño limpio y seco.

To take dirty, use a dry cloth, duster or vacuum. If necessary to take the dust, use a wet cloth. Finish with a clean and dry flannel.

IMPORTANTE / IMPORTANTE / IMPORTANT



Não utilize produtos abrasivos como álcool e detergentes, como também esponjas rígidas ou palha de aço na limpeza dos móveis. No use limpiadores abrasivos como alcohol y detergentes, así como esponjas rígidas o lana de acero para limpiar los muebles. Do not use abrasives such as alcohol and detergent, tough soaker also steel wool to clean the furniture.



Proteja a superfície do móvel de objetos que transmitam calor ou umidade. Proteja la superficie del mueble de objetos que transmitan calor o humedad. Protect the surface of the furniture against objects that can pass heat and humidity.



Evitar o contato de água e produto de limpeza com o rodapé do produto, pois poderá danificá-lo. Evitar el contacto con agua y producto de limpieza con el rodapé del producto, pues podrá dañarlo. Avoid the contact of water and cleaning products with baseboard, cause it should damage your product.



Procure sempre utilizar flanela limpa e seca para a limpeza. Busque siempre utilizar flanela limpia y seca para la limpieza. Try always to use a clean and dry flannel to cleaning.



Cuidado com objetos pontiagudos, eles podem arranhar a superfície das portas e tampo. Cuidado con objetos afilados, ellos pueden rayar la superficie de las puertas e la tapa. Take care with sharp objects, they can scratch the door lid surface.

INSTRUÇÃO DE INSTALAÇÃO DE TELEVISORES

INSTRUCCIÓN DE INSTALACIÓN DE TELEVISIÓN / TELEVISION INSTALLATION INSTRUCTION

Para o uso do maior televisor indicado recomendamos a instalação da TV no painel do produto.

Para utilizar el televisor más grande indicado, recomendamos la instalación del televisor en el panel del producto. To use the largest television indicated, we recommend installing the TV on the product panel.

TAMANHO DE TV SUGERIDO

TAMANO DE TELEVISOR SUGERIDO
SUGGESTED TV SIZE

50"

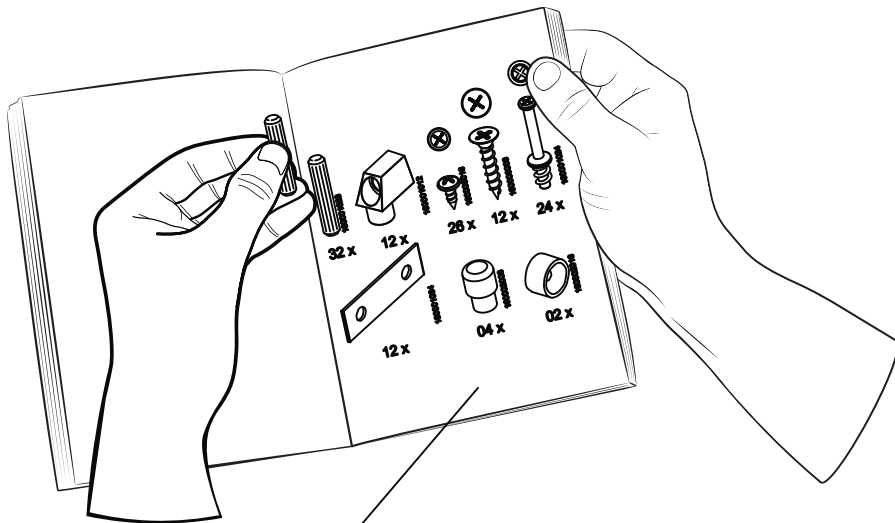

Preste Atenção! ¡Preste atención! Attention!



As ferragens dos nossos manuais são sempre apresentadas nas mesmas proporções da peça na vida real. Caso apareça alguma dúvida no decorrer do processo de montagem, coloque a ferragem ao lado do desenho e faça a consulta :D

Los accesorios de nuestros manuales siempre se presentan en las mismas proporciones que la pieza en la vida real. Si tiene alguna duda durante el proceso de montaje, coloque los accesorios junto al dibujo y haga una consulta :D

The accessories in our manuals are always presented in the same proportions as the spare part in real life. If you have any questions during the assembly process, place the accessory next to the drawing and make an inquiry :D

Símbolos: Simbolos: Symbols:



- + Parafuso Phillips
- Parafuso Fenda
- ⊙ Parafuso Allen

- + Tornillo Philips
- Tornillo Ranurado
- ⊙ Tornillo Allen

- + Phillips screw
- Slotted Screw
- ⊙ Allenscrew

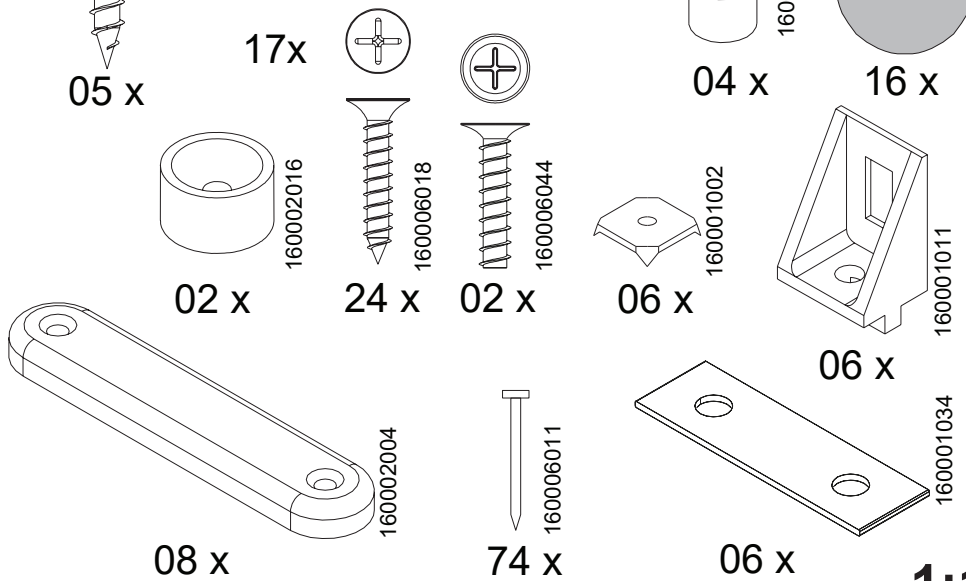
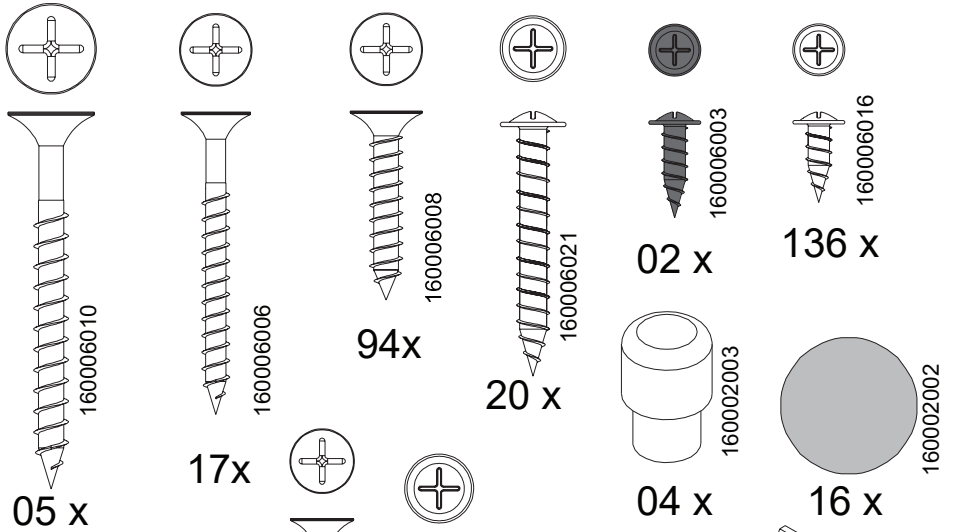
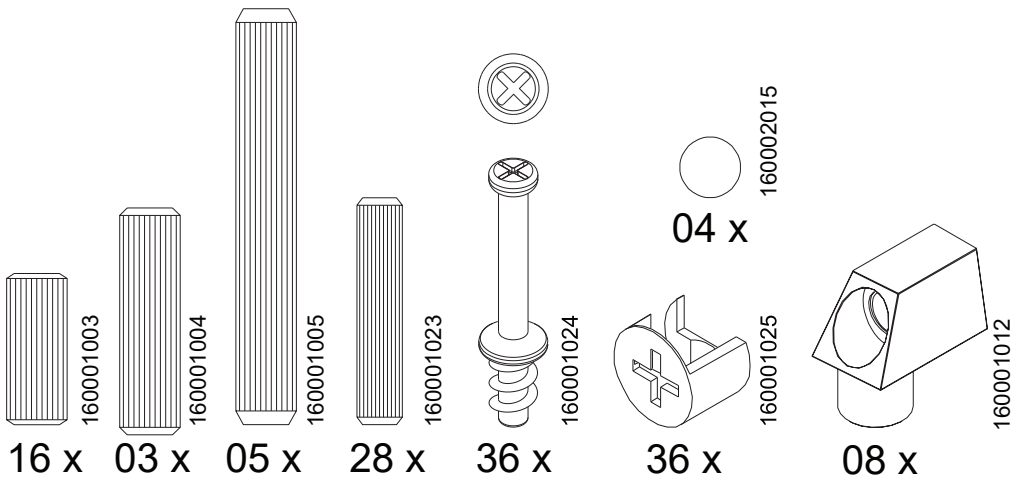

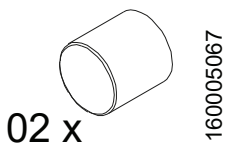
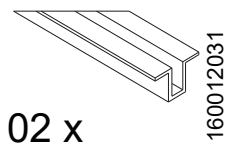
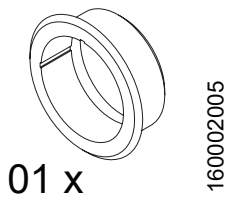
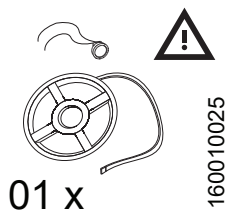
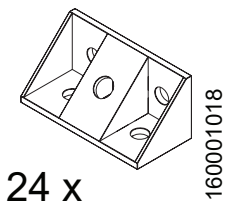
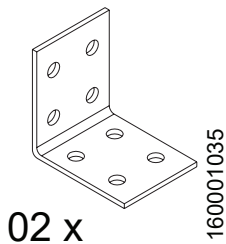
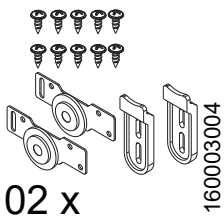

Item de compra opcional.

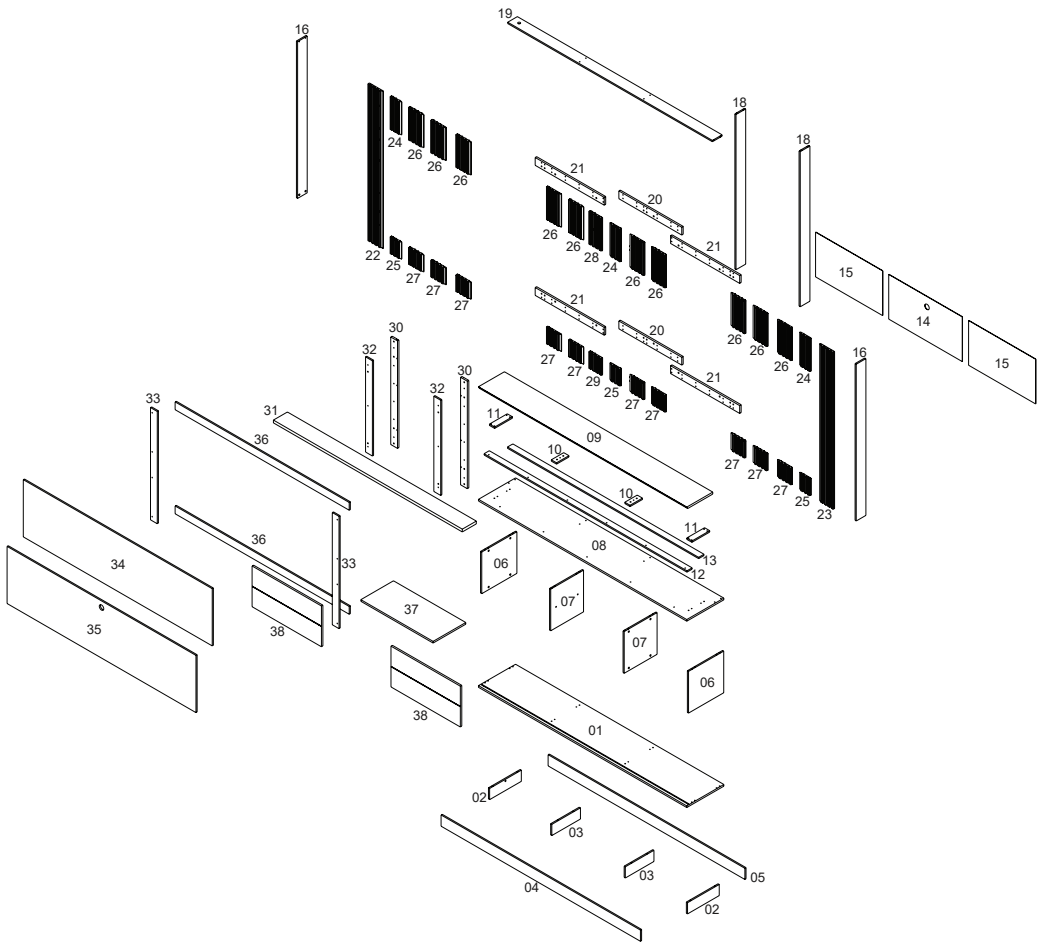

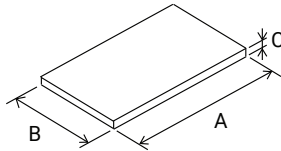

VOLUME Caja Box	ITEM Artículo Item	PEÇA Pieza Part	DESCRIÇÃO Descripción Description	DIMENSÕES (mm) Dimensión/Dimension			QUANTIDADE La Cantidad The Amount	MATERIAL
				A	B	C		
1	1	510269001	BASE	2154	384	15	1	MDP
1	2	510269002	RODAPE LATERAL	328	100	12	2	MDP
2	3	510269003	RODAPE CENTRAL	296	100	12	2	MDP
1	4	510269004	RODAPE FRONTAL	2062	100	12	1	MDP
1	5	510269005	RODAPE TRASEIRO	2034	100	12	1	MDP
3	6	510269006	LATERAL	373	362	12	2	MDP
3	7	510269007	DIVISÃO	373	340	12	2	MDP
1	8	510269008	TAMPO INFERIOR	2154	384	15	1	MDP
1	9	510269009	TAMPO SUPERIOR	2154	268	18	1	MDF
2	10	510269010	ENGROSSO CENTRAL	128	54	12	2	MDP
1	11	510269011	ENGROSSO LATERAL	184	54	12	2	MDP
1	12	510269012	ENGROSSO FRONTAL	2098	54	12	1	MDP
1	13	510269013	ENGROSSO TRASEIRO	1976	55	12	1	MDP
2	14	510269014	FUNDO CENTRAL (COM FURO)	760	400	2.8	1	MDF
2	15	510269015	FUNDO LATERAL	692	400	2.8	2	MDF
1	16	510269016	TRAVESSA LATERAL	1403	100	12	2	MDP
1	18	510269018	TRAVESSA CENTRAL	1389	100	12	2	MDP
1	19	510269019	TRAVESSA SUPERIOR	2116	100	12	1	MDP
3	20	510269020	TRAVESSA APOIO CENTRAL MOLDURA	650	70	15	2	MDP
3	21	510269021	TRAVESSA APOIO LATERAL MOLDURA	714	70	15	4	MDP
2	22	510269022	MOLDURA LATERAL ESQUERDA	1405	147	15	1	MDF
1	23	510269023	MOLDURA LATERAL DIREITA	1405	147	15	1	MDF
3	24	510269024	MOLDURA CENTRAL ESTREITA SUPERIOR	293	110	15	3	MDF
3	25	510269025	MOLDURA CENTRAL ESTREITA INFERIOR	150	110	15	3	MDF
2	26	510269026	MOLDURA CENTRAL LARGA SUPERIOR	293	147	15	10	MDF
2	27	510269027	MOLDURA CENTRAL LARGA INFERIOR	150	147	15	10	MDF
3	28	510269028	MOLDURA CENTRAL SUPERIOR (COM FURO)	293	120	15	1	MDF
3	29	510269029	MOLDURA CENTRAL INFERIOR (COM FURO)	150	120	15	1	MDF
2	30	510269030	TRAVESSA APOIO	962	70	15	2	MDP
2	31	510269031	PRATELEIRA SUPERIOR	1954	145	25	1	MDP
2	32	510269032	TRAVESSA LED CENTRAL	842	71	12	2	MDP
2	33	510269033	TRAVESSA LED LATERAL	1006	70	12	2	MDP
2	34	510269034	PAINEL TV SUPERIOR	1954	513	12	1	MDP
2	35	510269035	PAINEL TV INFEIROR (COM FURO)	1954	513	12	1	MDP
2	36	510269036	TRAVESSA LED SUPERIOR INFERIOR	1794	70	12	2	MDP
1	37	510269037	PRATELEIRA MOVEL	747	388	15	1	MDP
3	38	510269038	PORTA	718	366	15	2	MDF

ARTÍCULO	DESCRIPCIÓN
1	BASE
2	ZOCALO LATERAL
3	ZOCALO CENTRAL
4	ZOCALO FRONTAL
5	ZOCALO TRASERO
6	LATERAL
7	DIVISION
8	BASE INFERIOR
9	BASE SUPERIOR
10	APOYO CENTRAL
11	APOYO LATERAL
12	APOYOFRONTAL
13	APOYO DEL FONDO
14	FONDO CENTRAL (CON AGUJERO)
15	FONDO LATERAL
16	TRAVESAÑO LATERAL
18	TRAVESAÑO CENTRAL
19	TRAVESAÑO SUPERIOR
20	TRAVESAÑO DE APOYO CENTRAL DEL MARCO
21	TRAVESAÑO DE APOYO LATERAL DEL MARCO
22	MARCO LATERAL IZQUIERDO
23	MARCO LATERAL DERECHO
24	MARCO CENTRAL ESTRECHO SUPERIOR
25	MARCO CENTRAL ESTRECHO INFERIOR
26	MARCO CENTRAL ANCH SUPERIOR
27	MARCO CENTRAL ANCHO INFERIOR
28	MARCO CENTRAL SUPERIOR (CON AGUJERO)
29	MARCO CENTRAL INFERIOR (CON AGUJERO)
30	TRAVESAÑO DE APOYO
31	REPISA SUPERIOR
32	TRAVESAÑO DEL LED CENTRAL
33	TRAVESAÑO DEL LED LATERAL
34	PANEL TV SUPERIOR
35	PANEL TV INFERIOR (CON AGUJERO)
36	TRAVESAÑO DEL LED SUPERIOR INFERIOR
37	REPISA MOVIL
38	PUERTA

ITEM	DESCRIPTION
1	BASE
2	SIDE BASEBOARD
3	CENTRAL BASEBOARD
4	FRONT BASEBOARD
5	BACK BASEBOARD
6	LEFT
7	DIVISION
8	BOTTOM BASE
9	TOP BASE
10	CENTRAL SUPORT
11	SIDE SUPORT
12	FRONTAL SUPPORT
13	BACK SUPPORT
14	CENTRAL BACK (WHITE HOLE)
15	LATERAL BACK
16	SIDE CROSSBAR
18	CENTRAL CROSSBAR
19	TOP CROSSBAR
20	CENTRAL SUPPORT OF THE FRAME
21	SIDE SUPPORT OF THE FRAME
22	LEFT FRAME
23	RIGHT FRAME
24	NARROW CENTER TOP FRAME
25	NARROW CENTER BOTTOM FRAME
26	WIDE CENTER TOP FRAME
27	WIDE CENTER BOTTOM FRAME
28	TOP CENTER FRAME (WITH HOLE)
29	BOTTOM CENTER FRAME (WITH HOLE)
30	SUPPORT CROSSBAR
31	UPPER SHELF
32	CENTRAL LAMP CROSSBAR
33	SIDE LAMP CROSSBAR
34	TOP TV PANEL
35	BOTTOM TV PANEL (WITH HOLE)
36	BOTTOM AND TOP LAMP CROSSBAR
37	MOBILE SHELF
38	DOOR

1

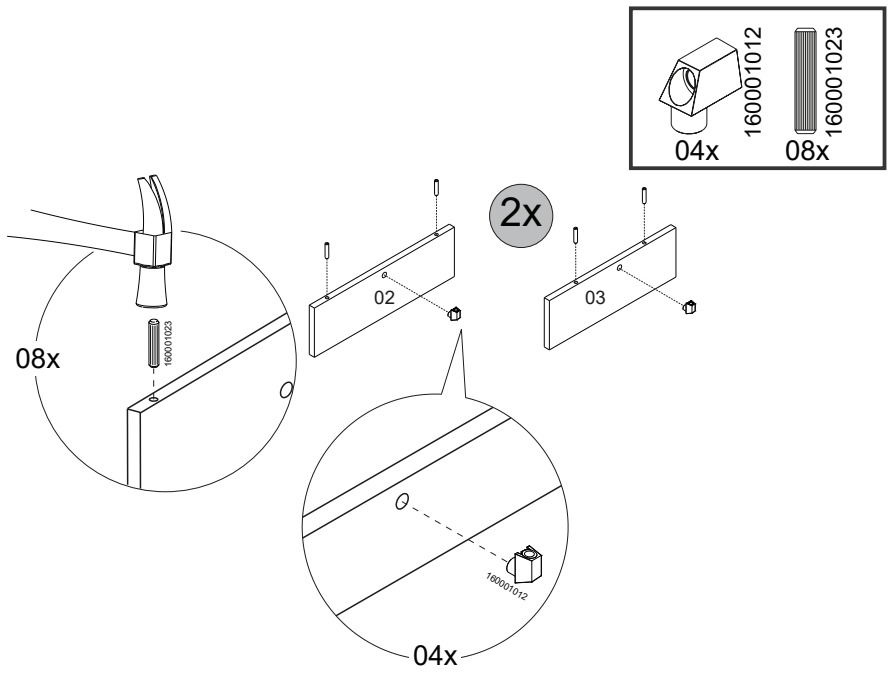

2

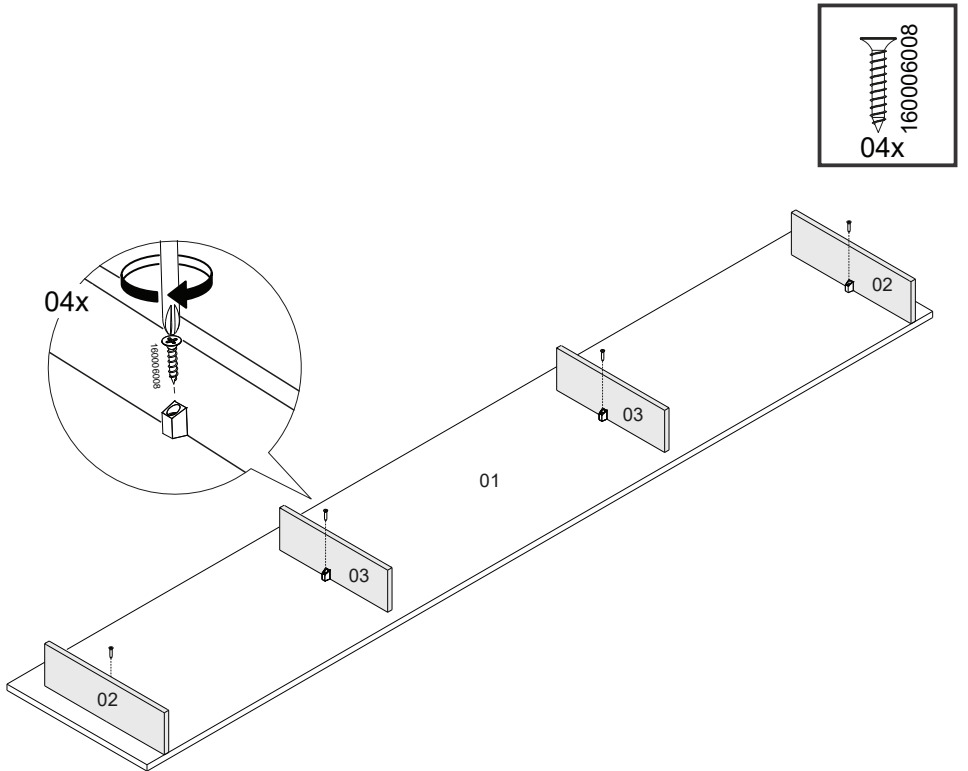

3

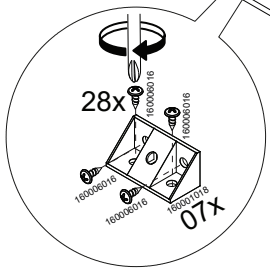
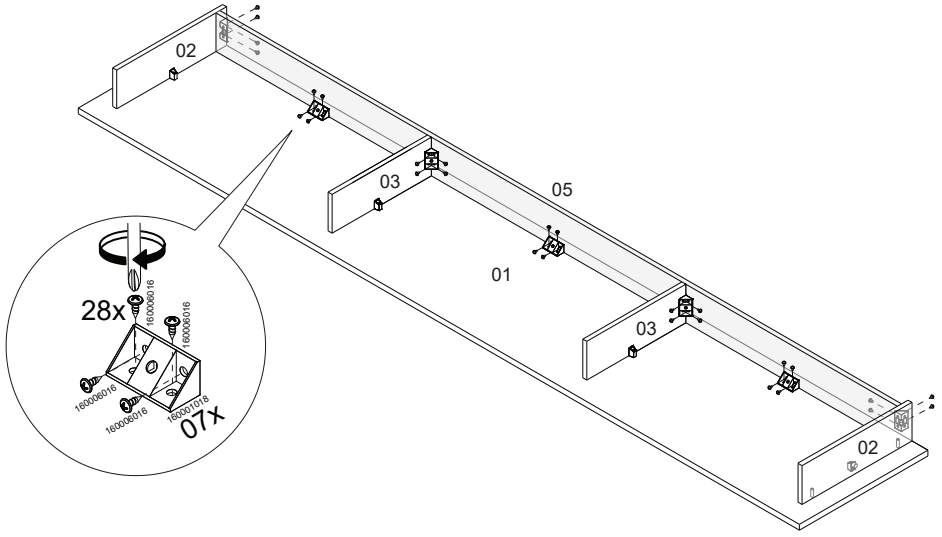
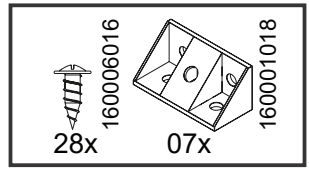

4

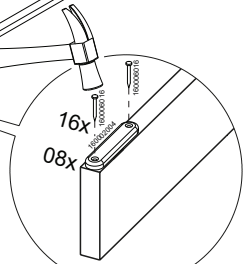
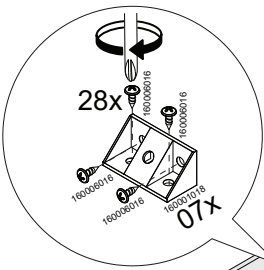
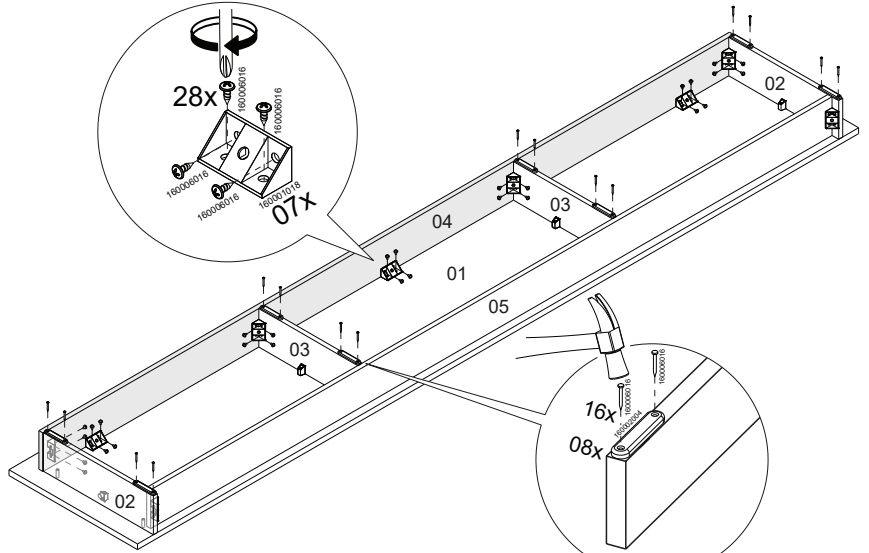
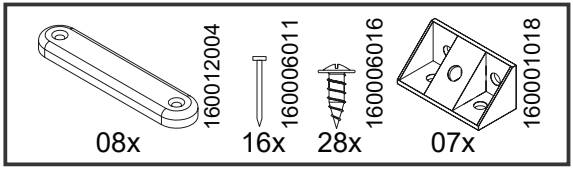

5

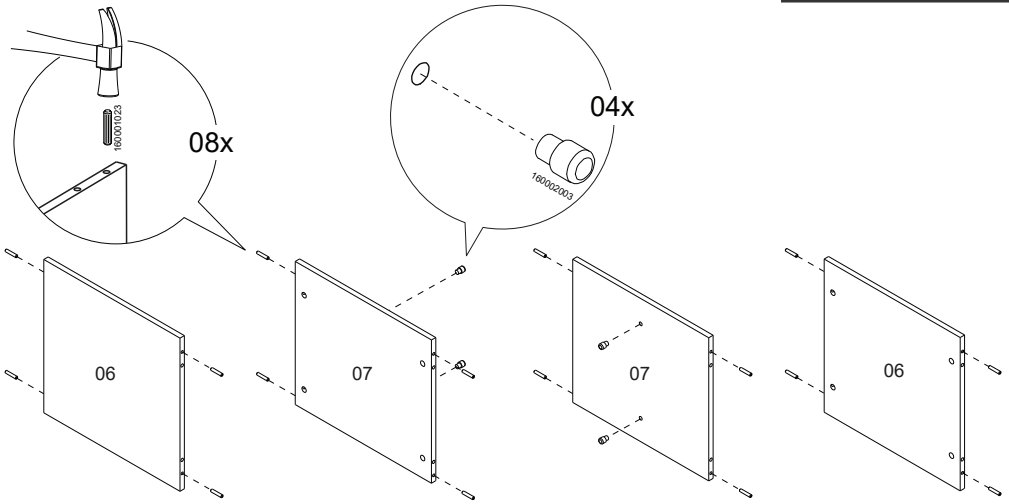
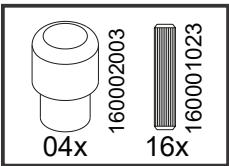

6

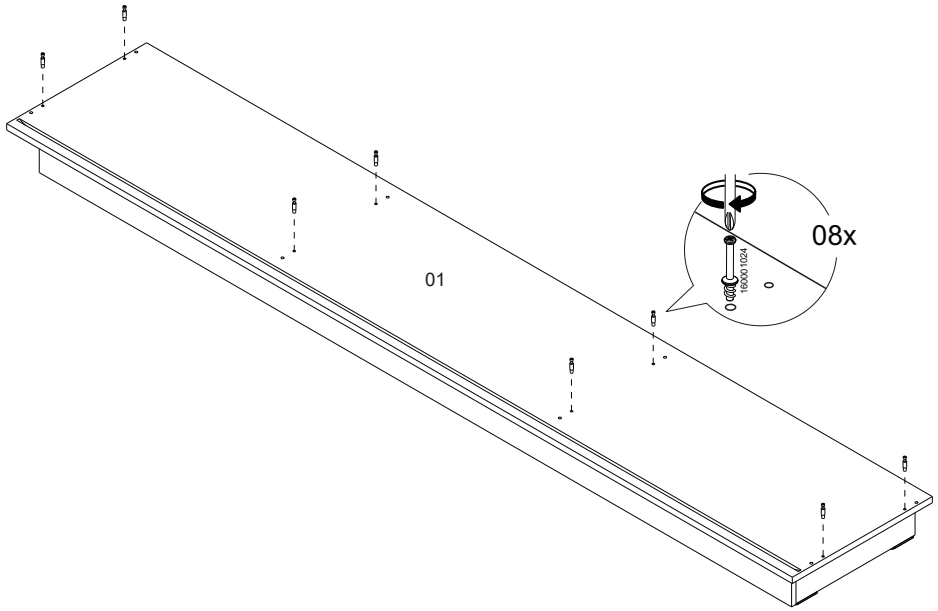
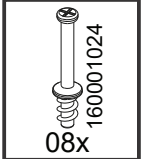

7

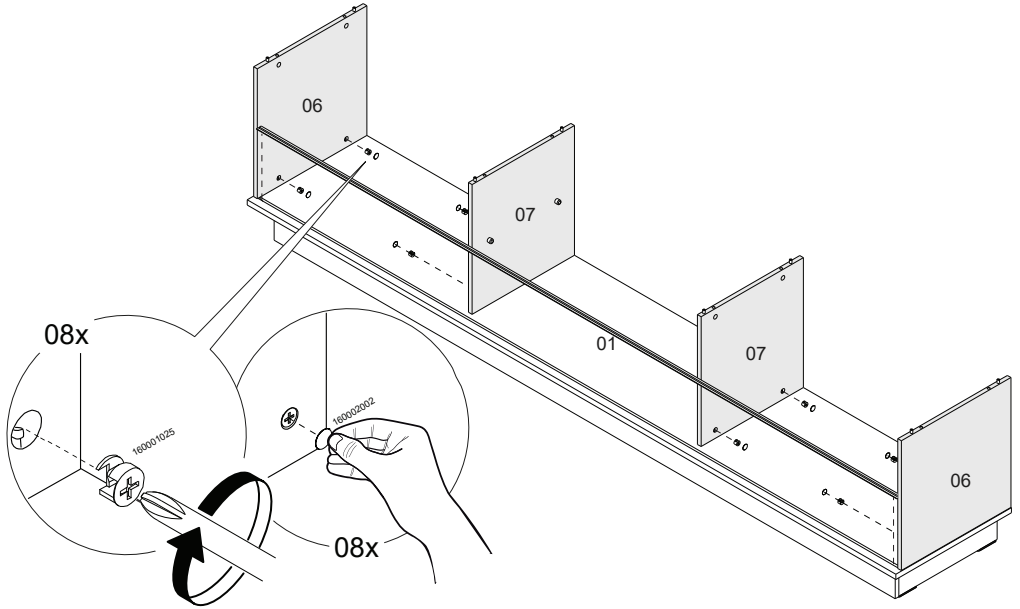
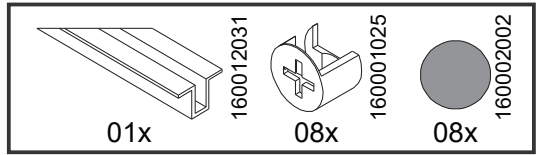

8

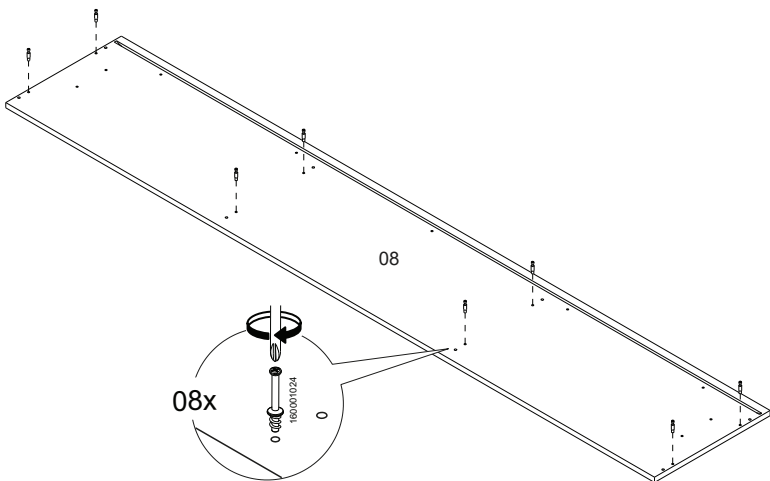
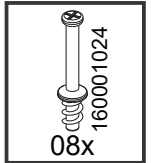

9

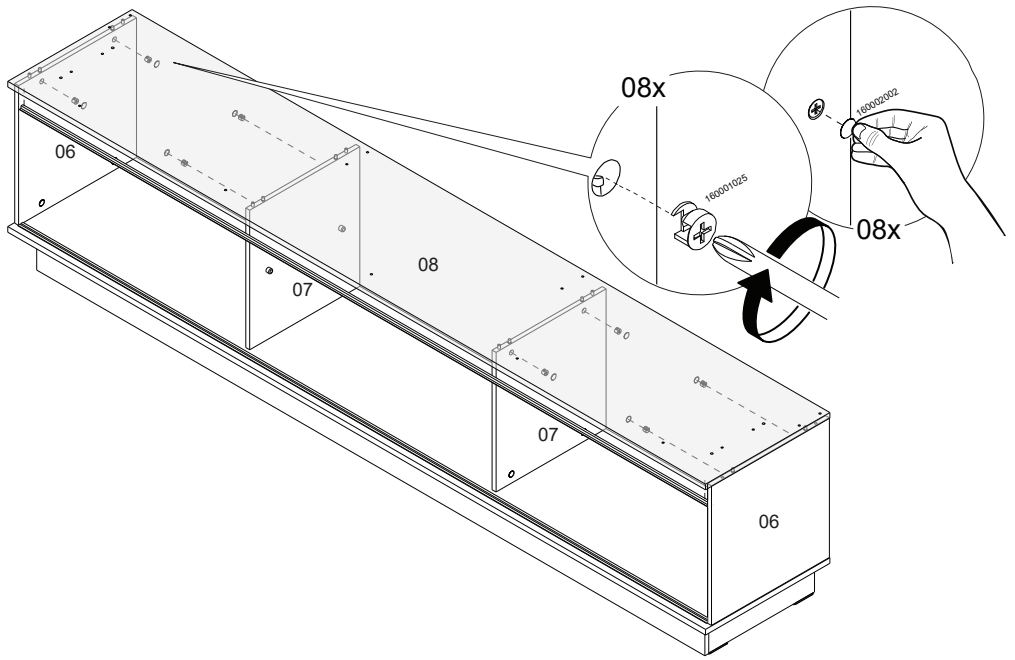
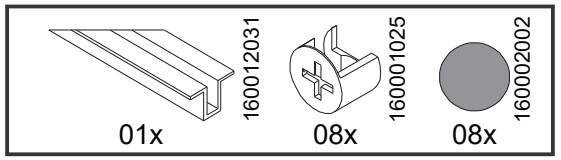

10

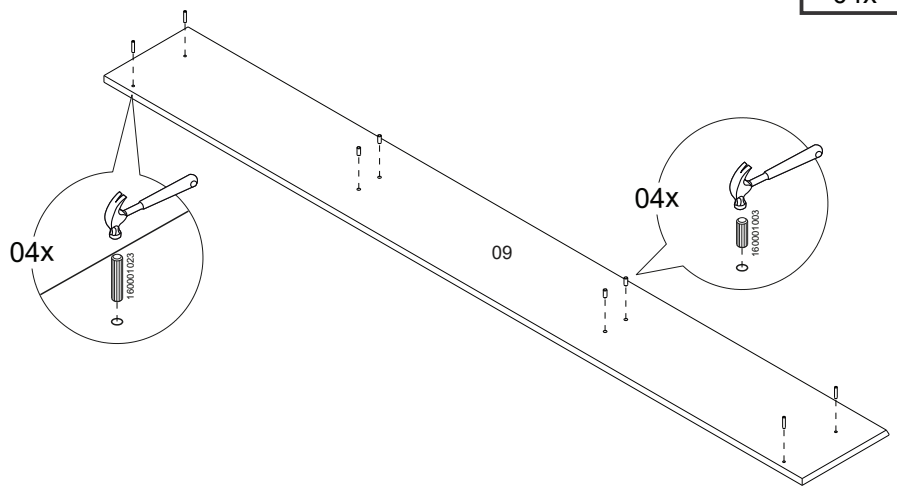
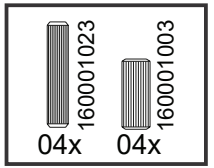

11

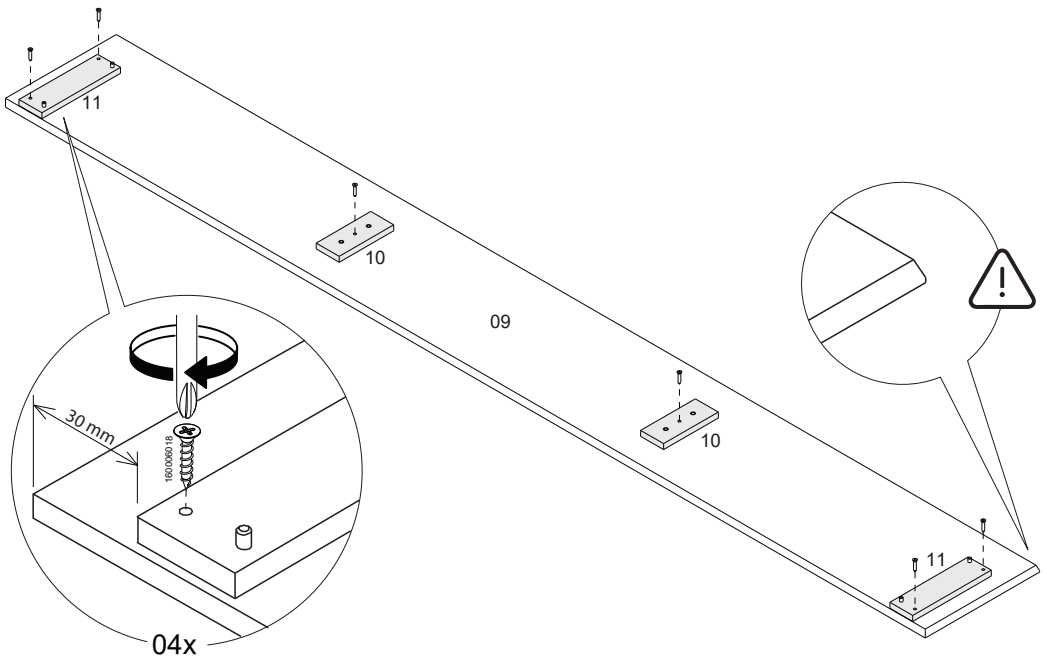
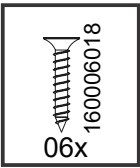

12

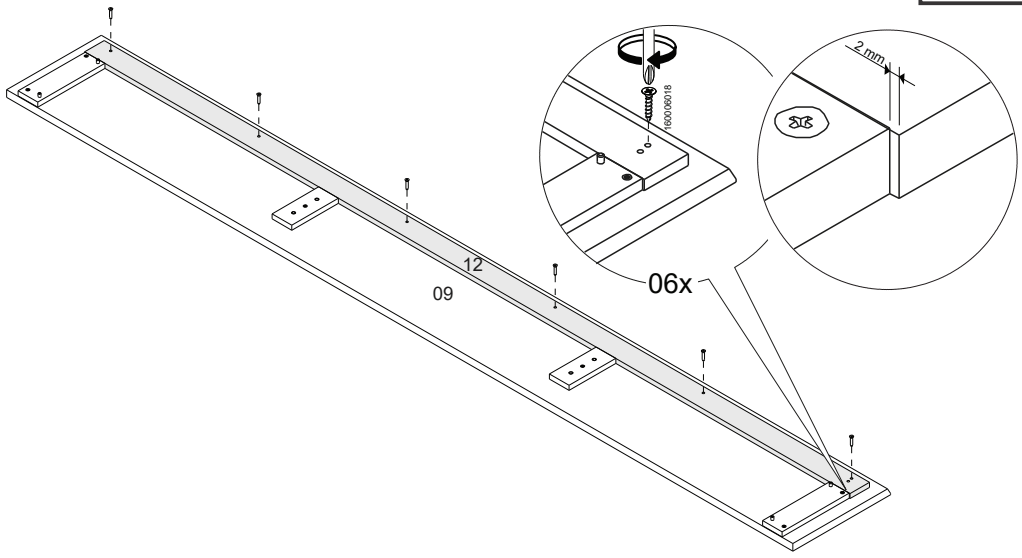
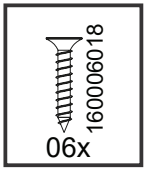

13

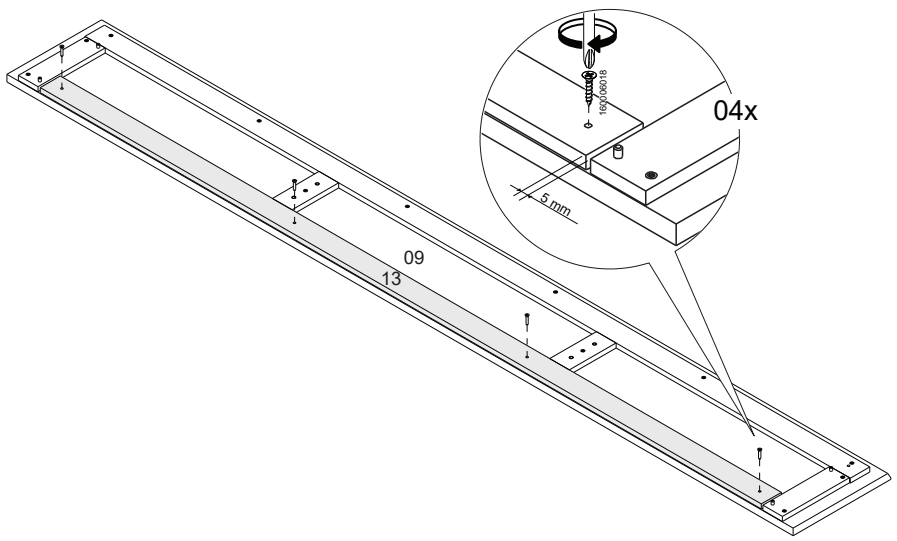
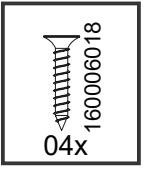

14

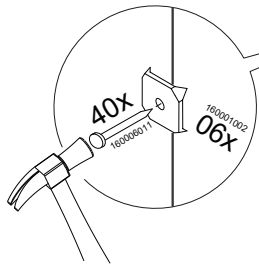
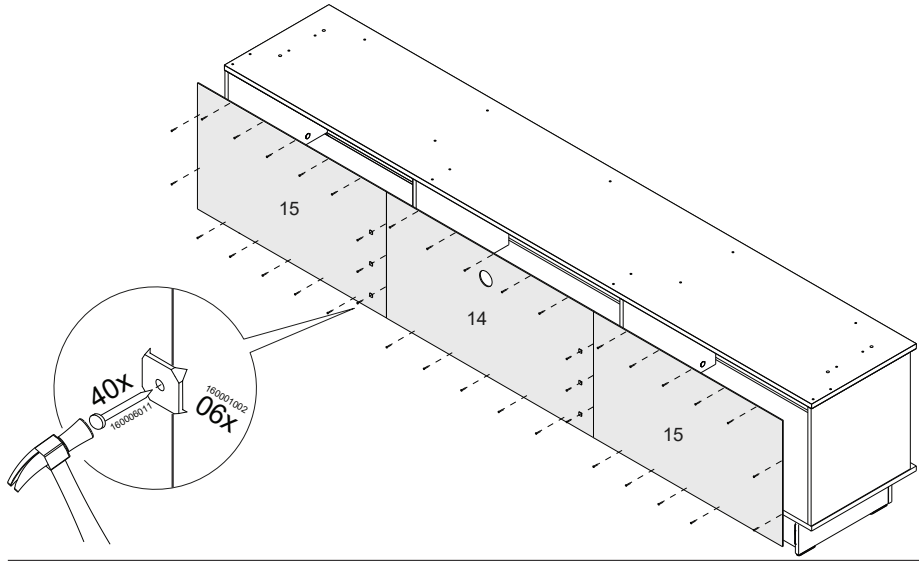
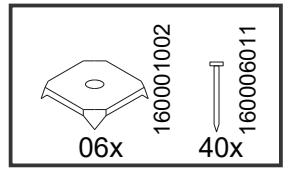

15

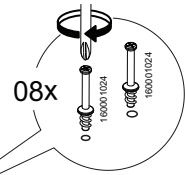
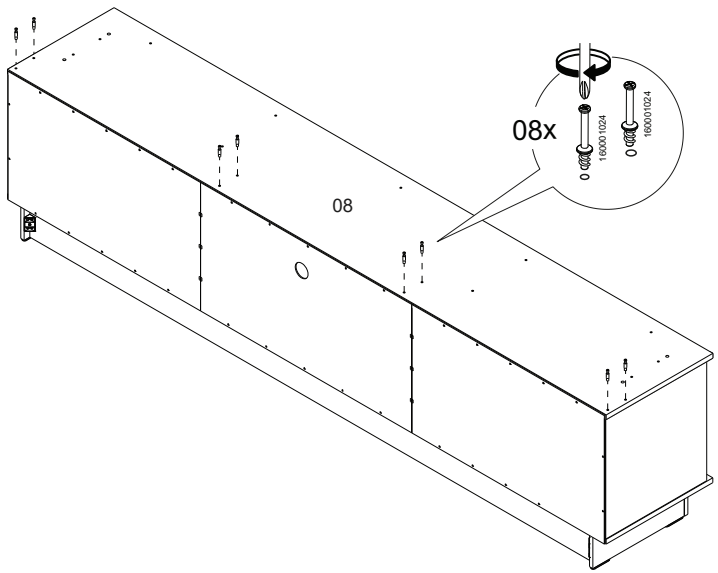
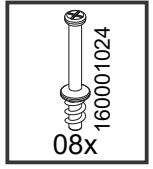

16

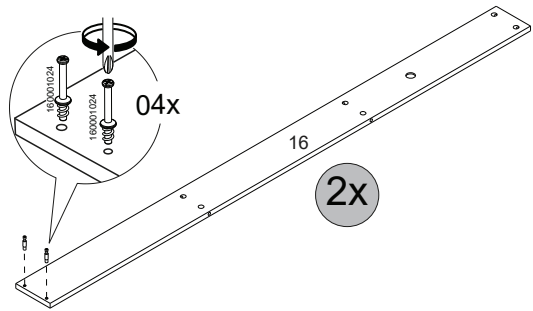
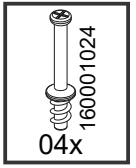

17

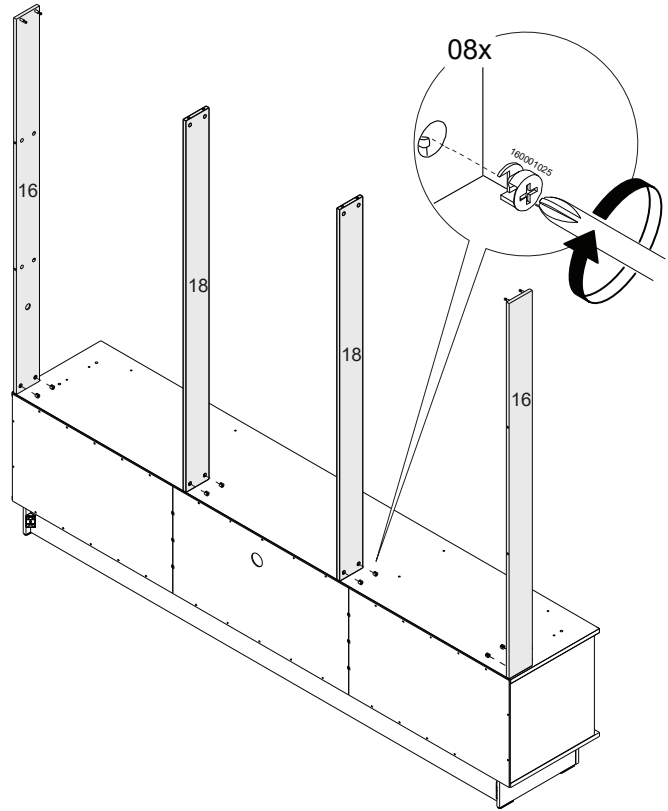
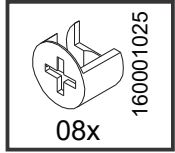
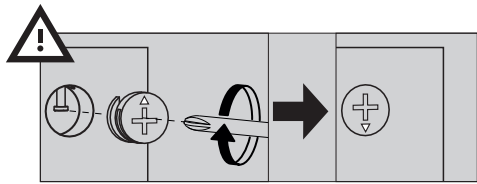

18

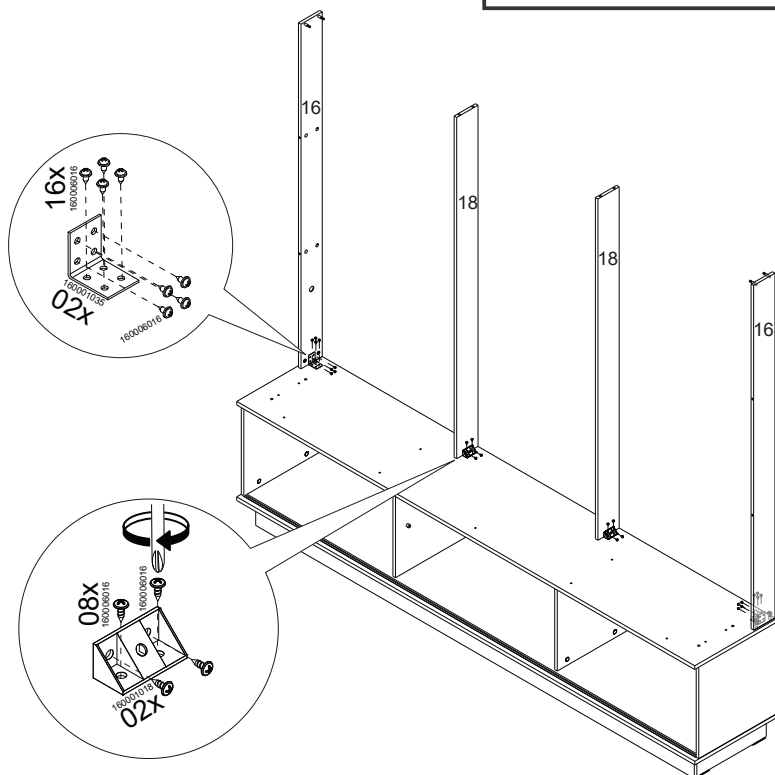
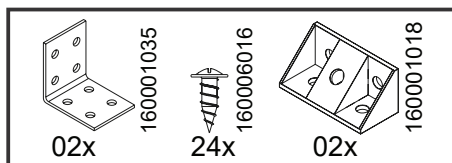

19

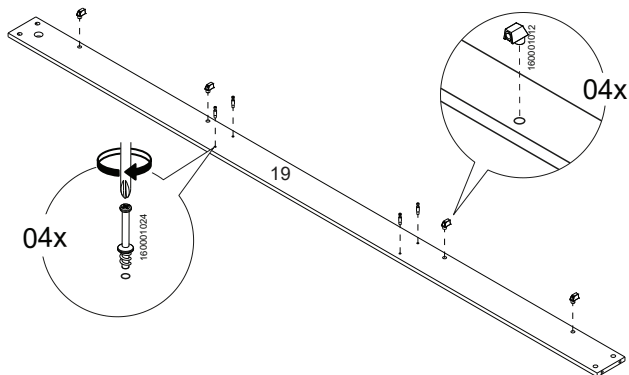
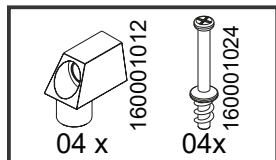

20

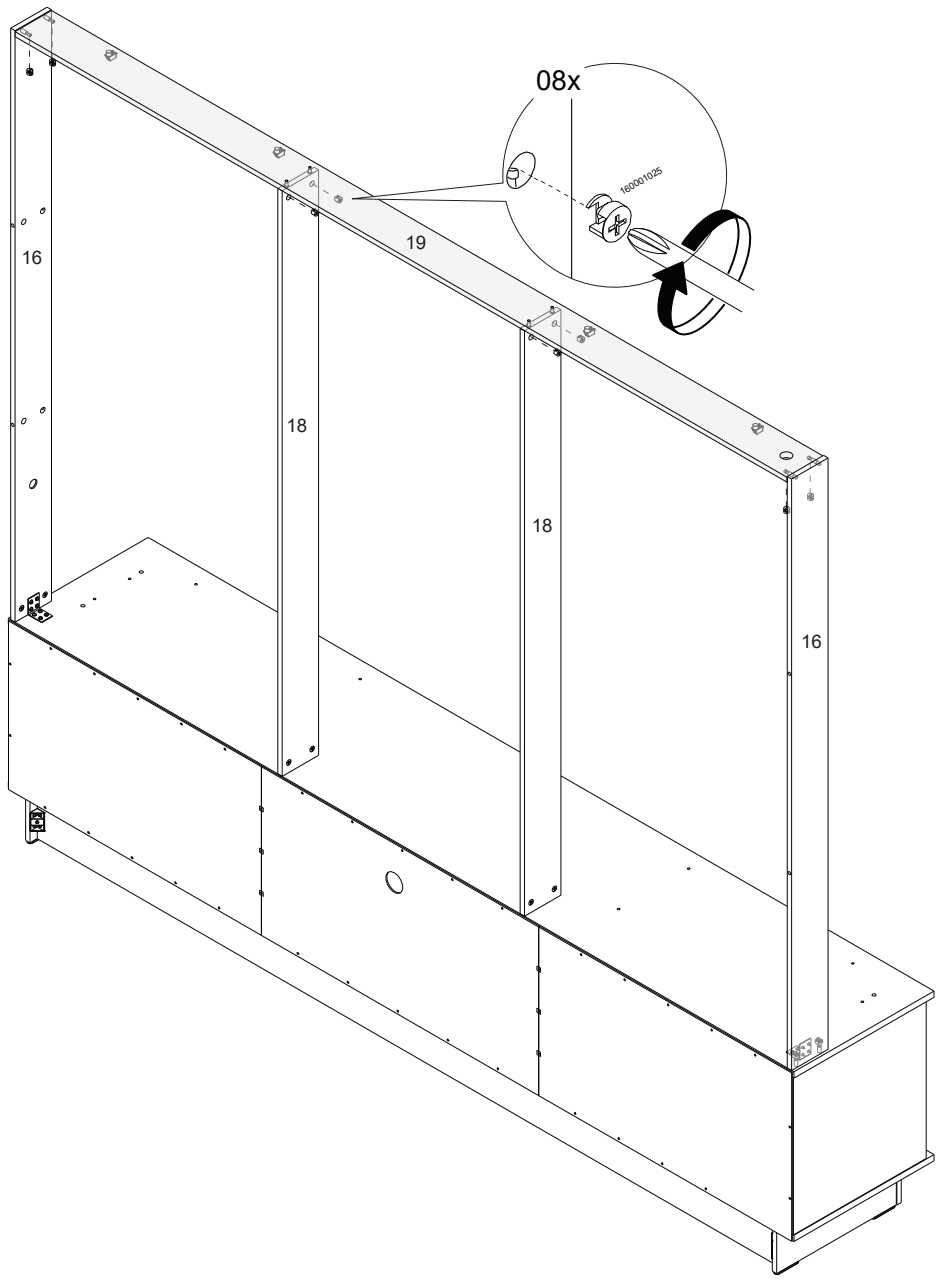
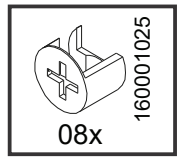
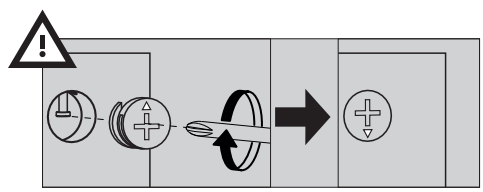

21

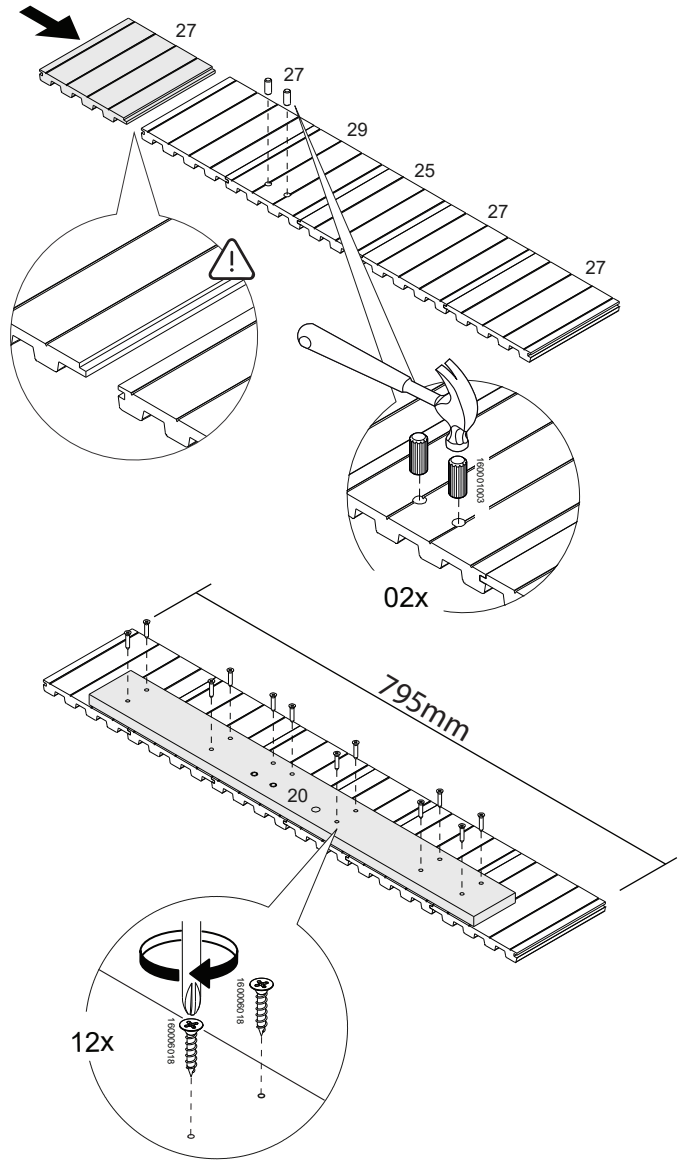
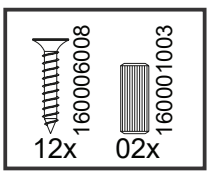
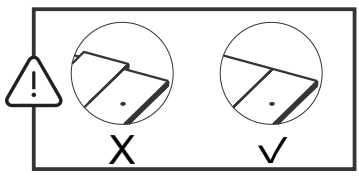

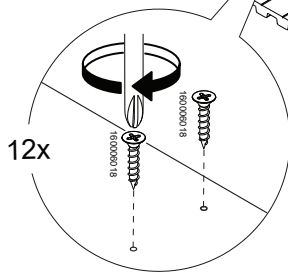
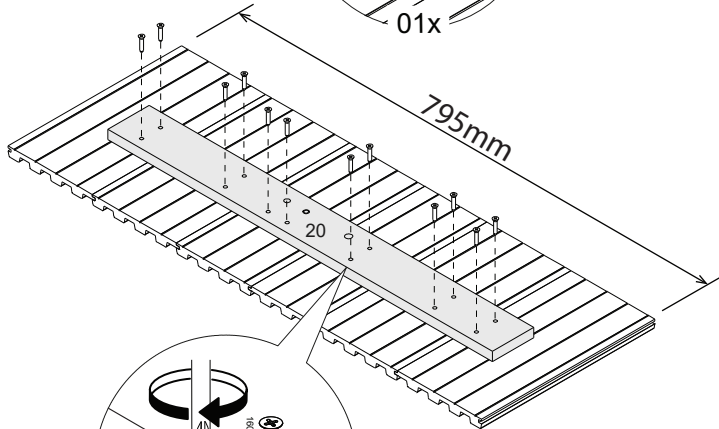
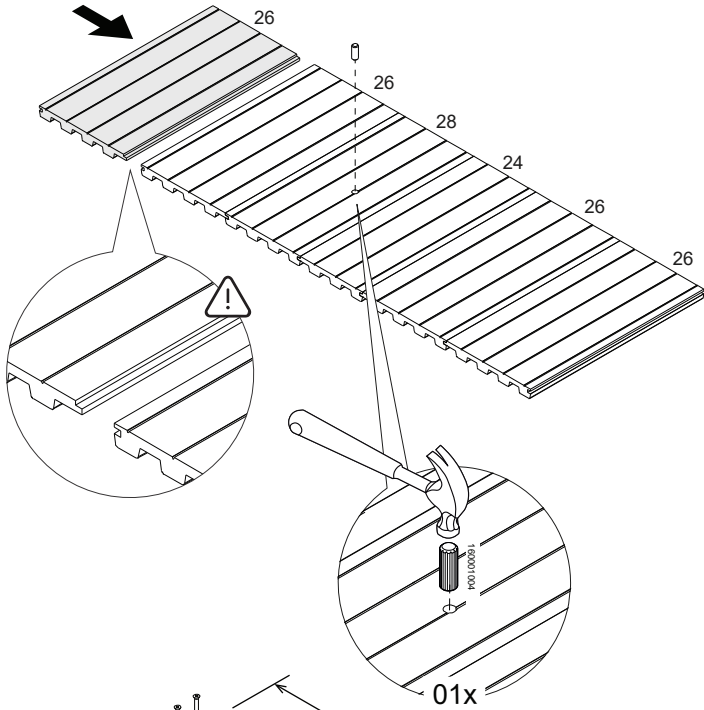
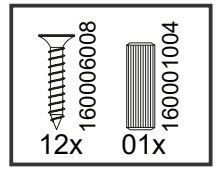
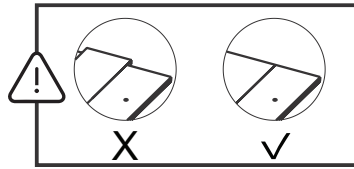

23

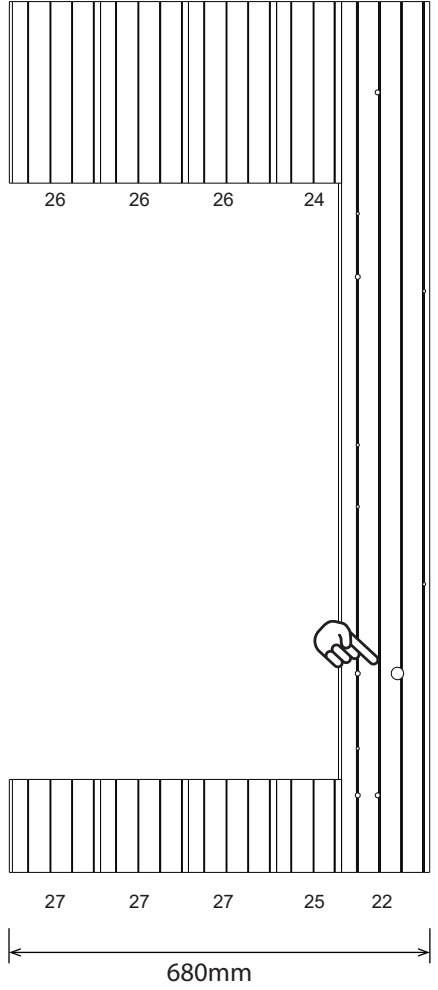
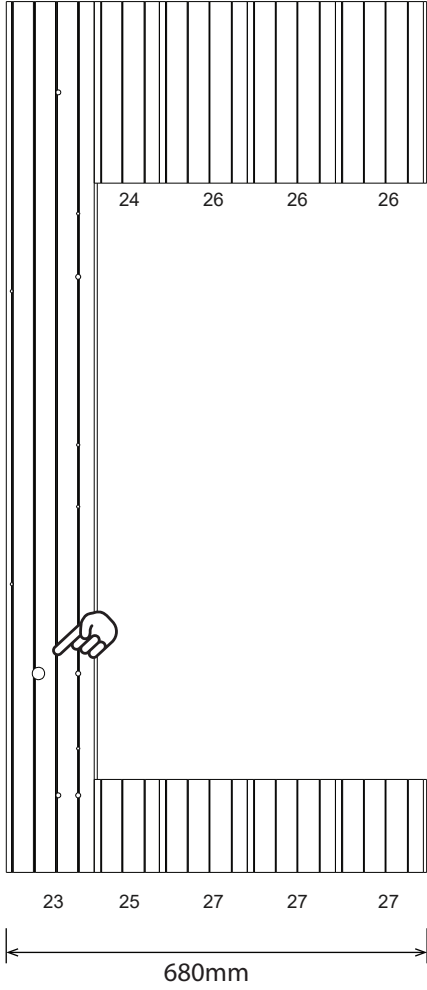
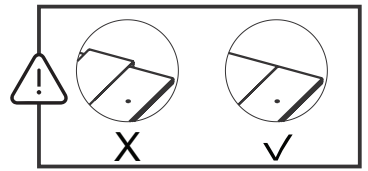

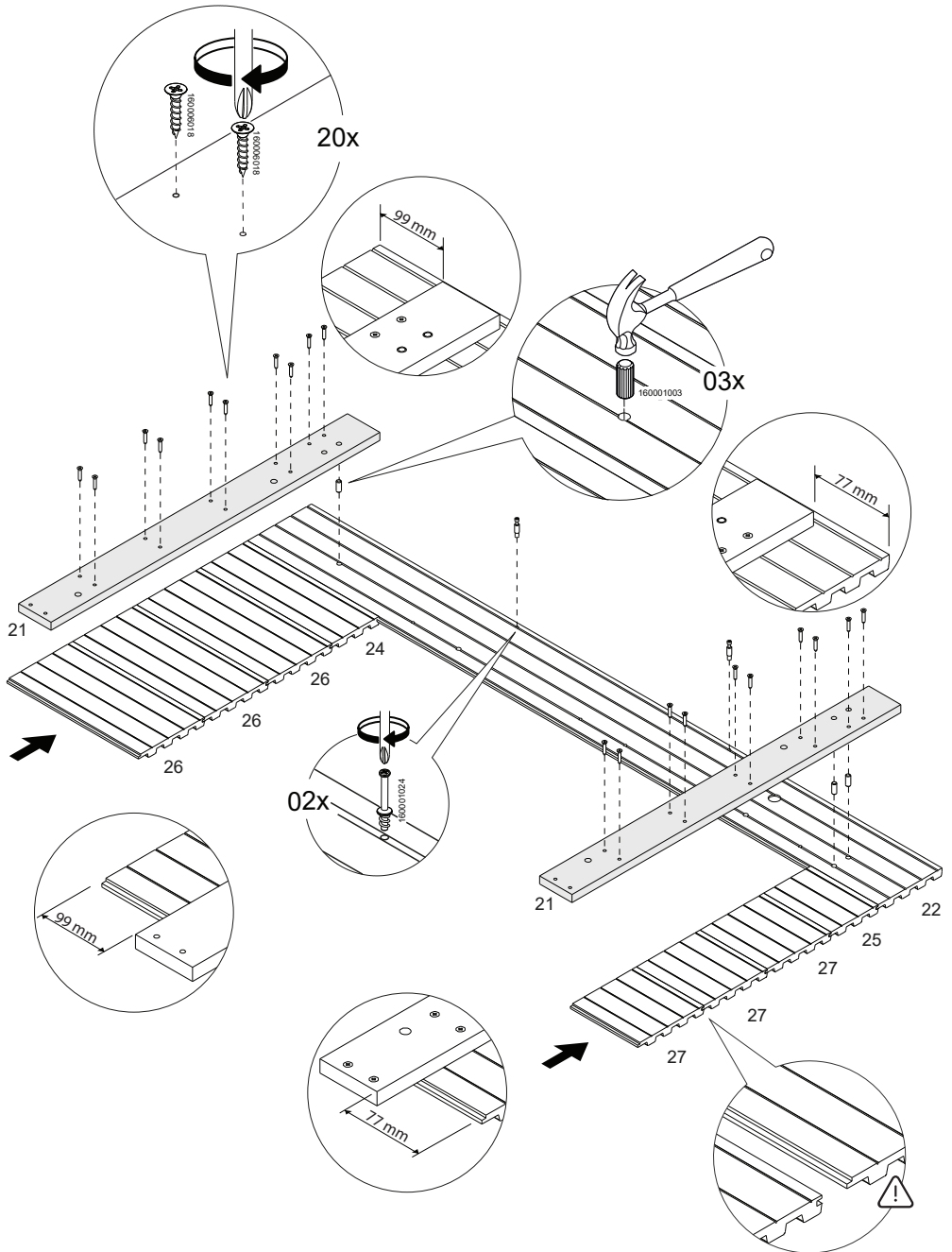
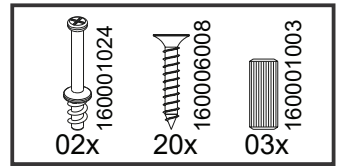

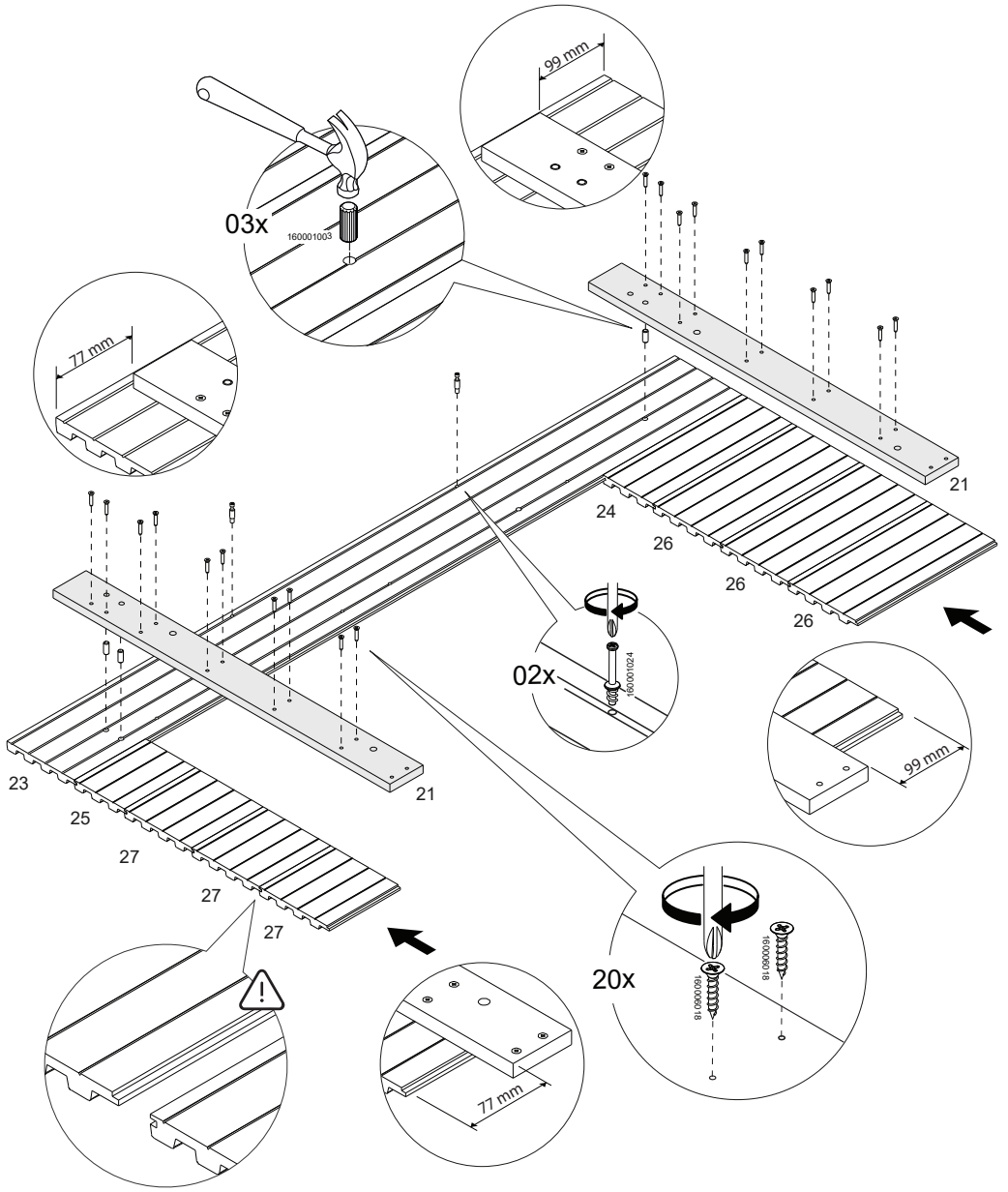
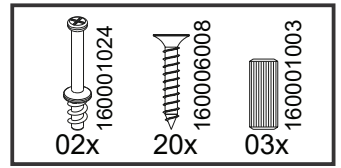

26

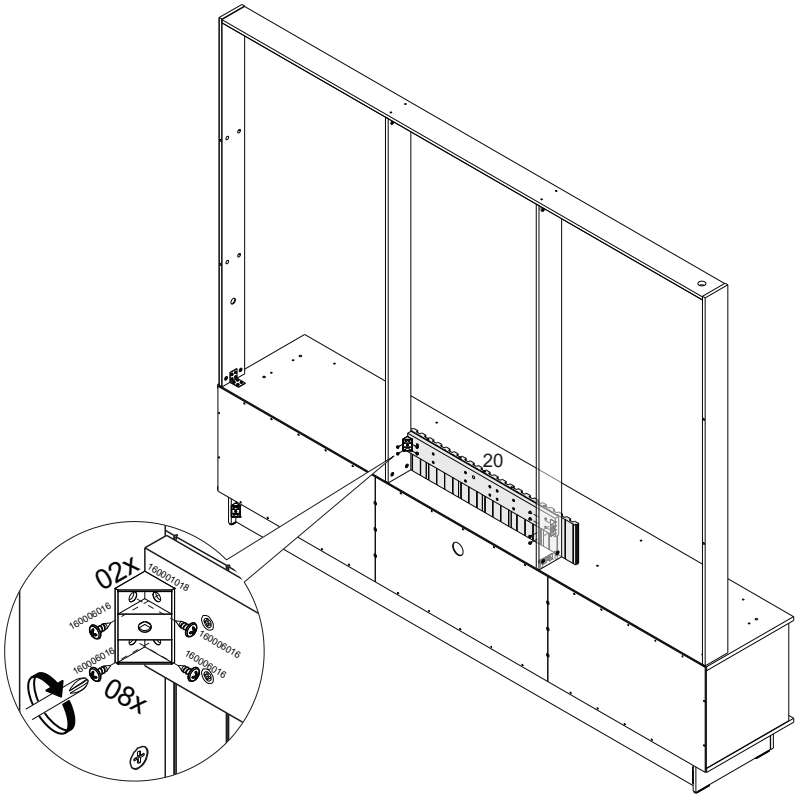
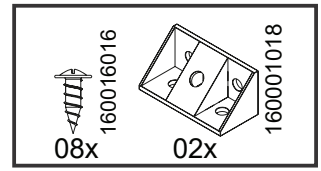

27

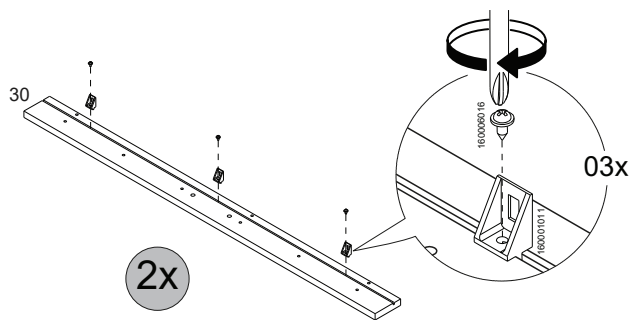
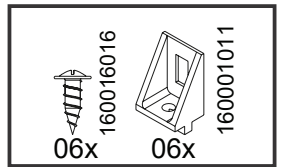

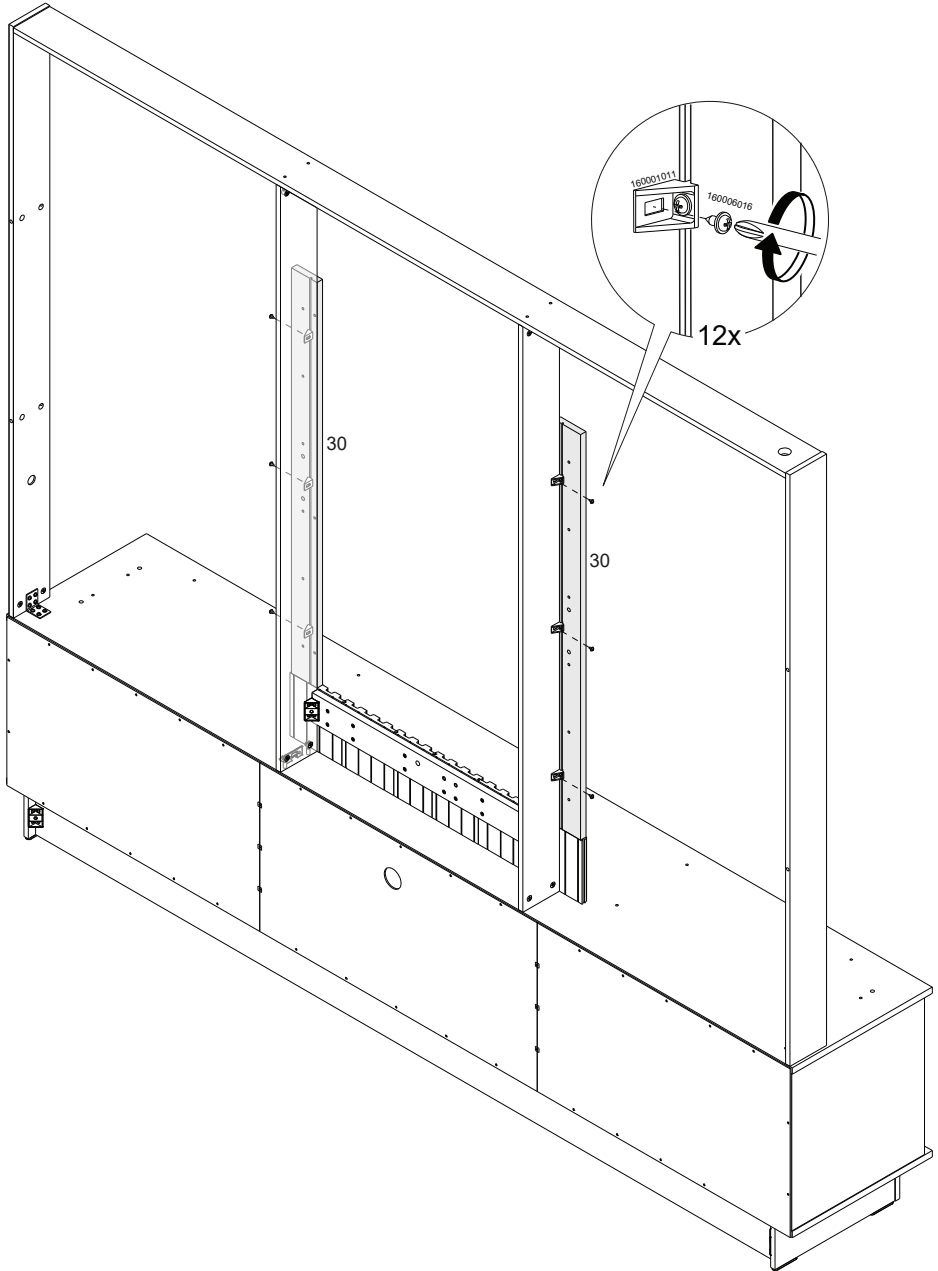
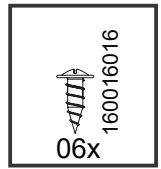

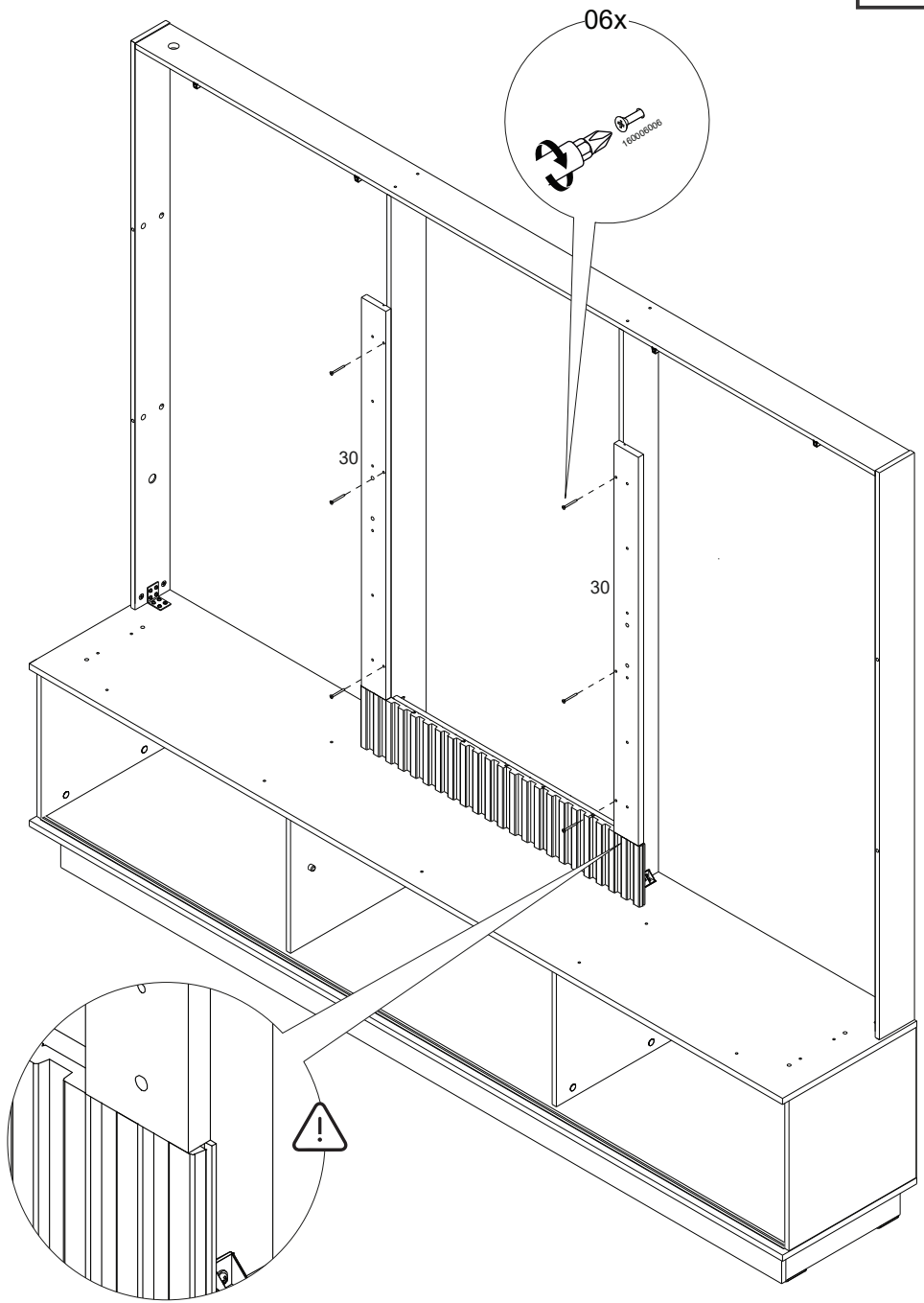
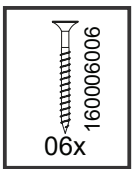



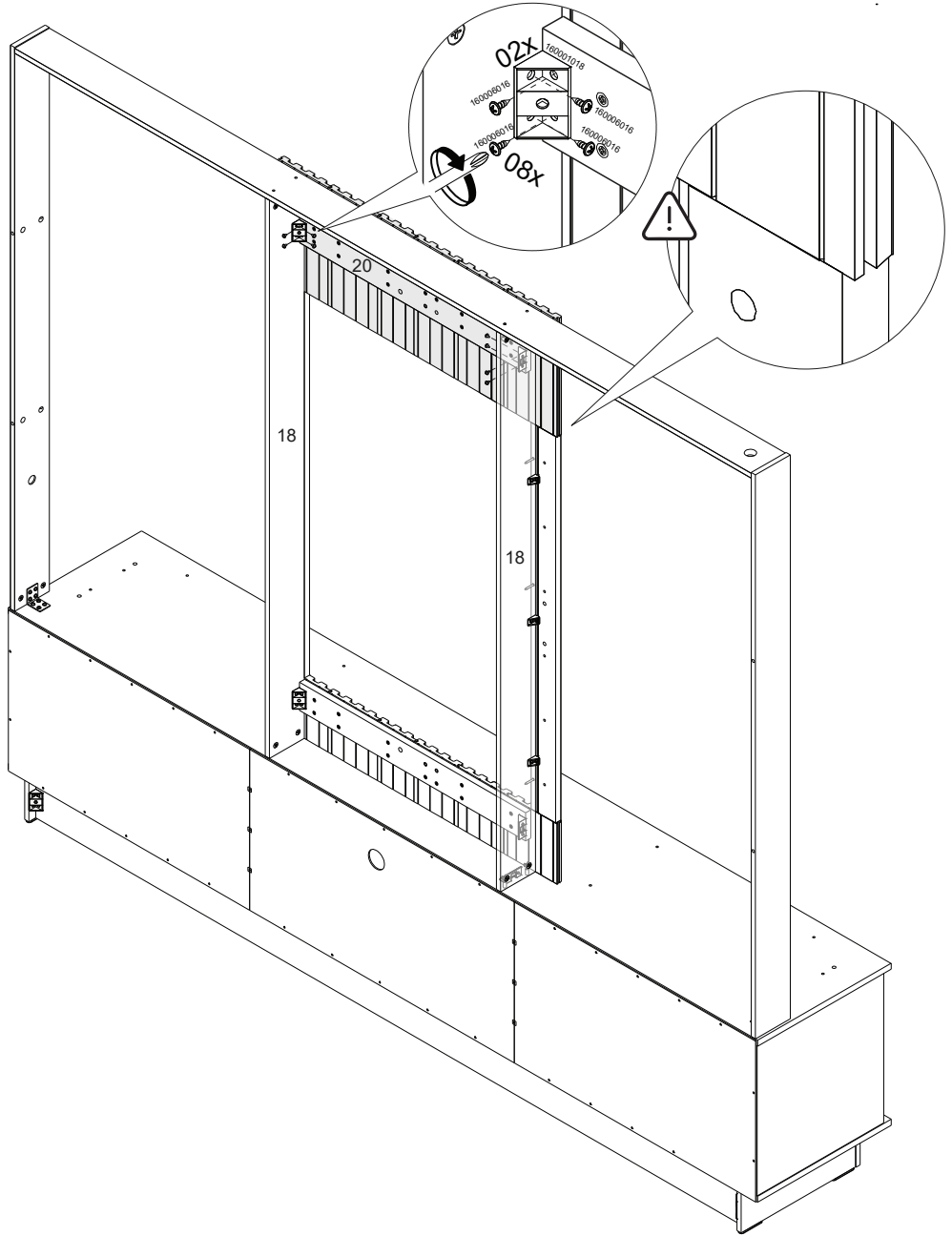
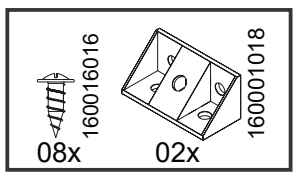

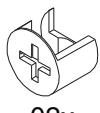
30

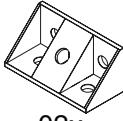
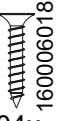

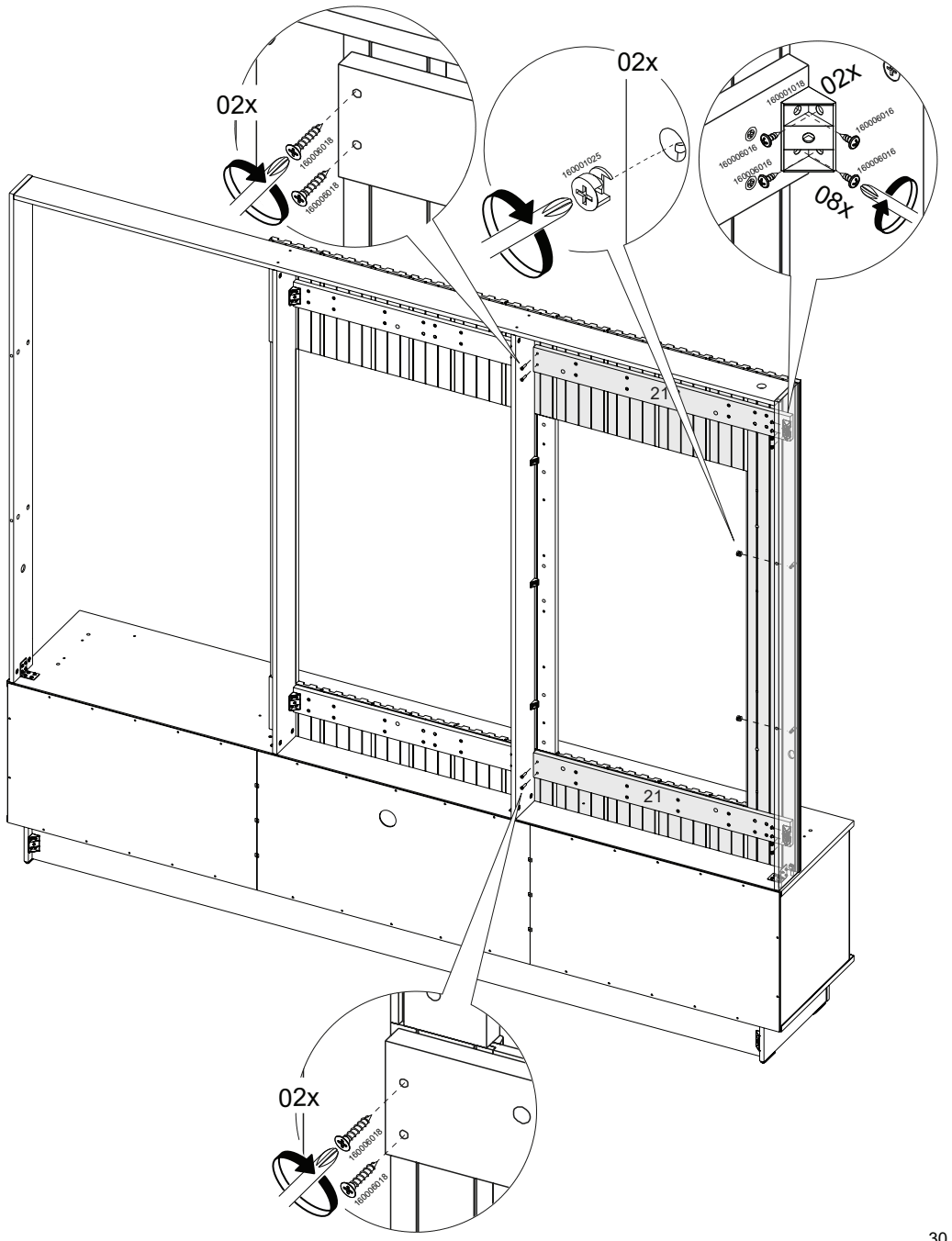
	160001025		160016016		160001018		160006018
02x		08x		02x		04x	

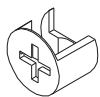

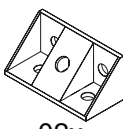
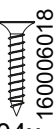
	160001025		160016016		160001018		160006018
02x		08x		02x		04x	

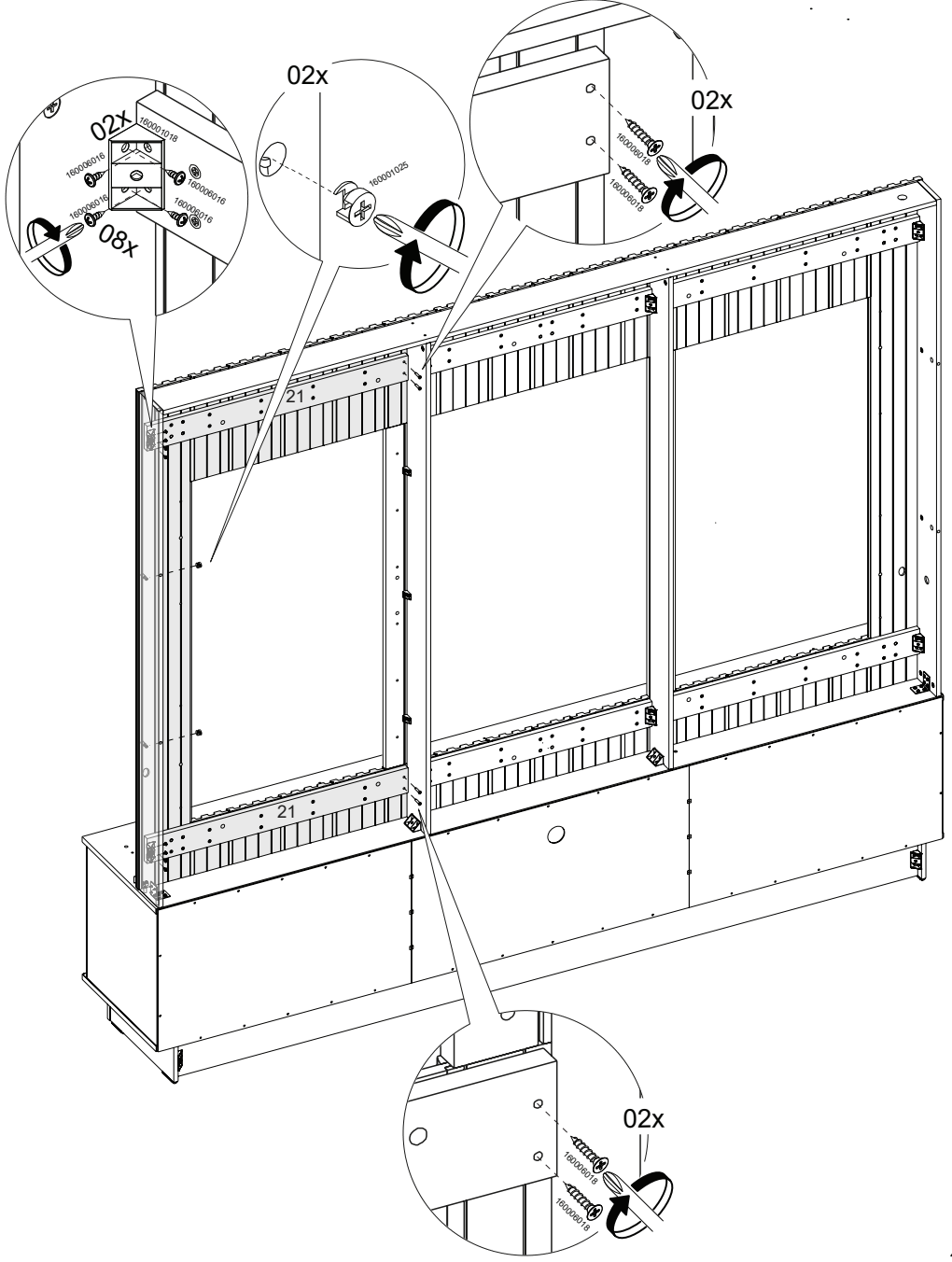

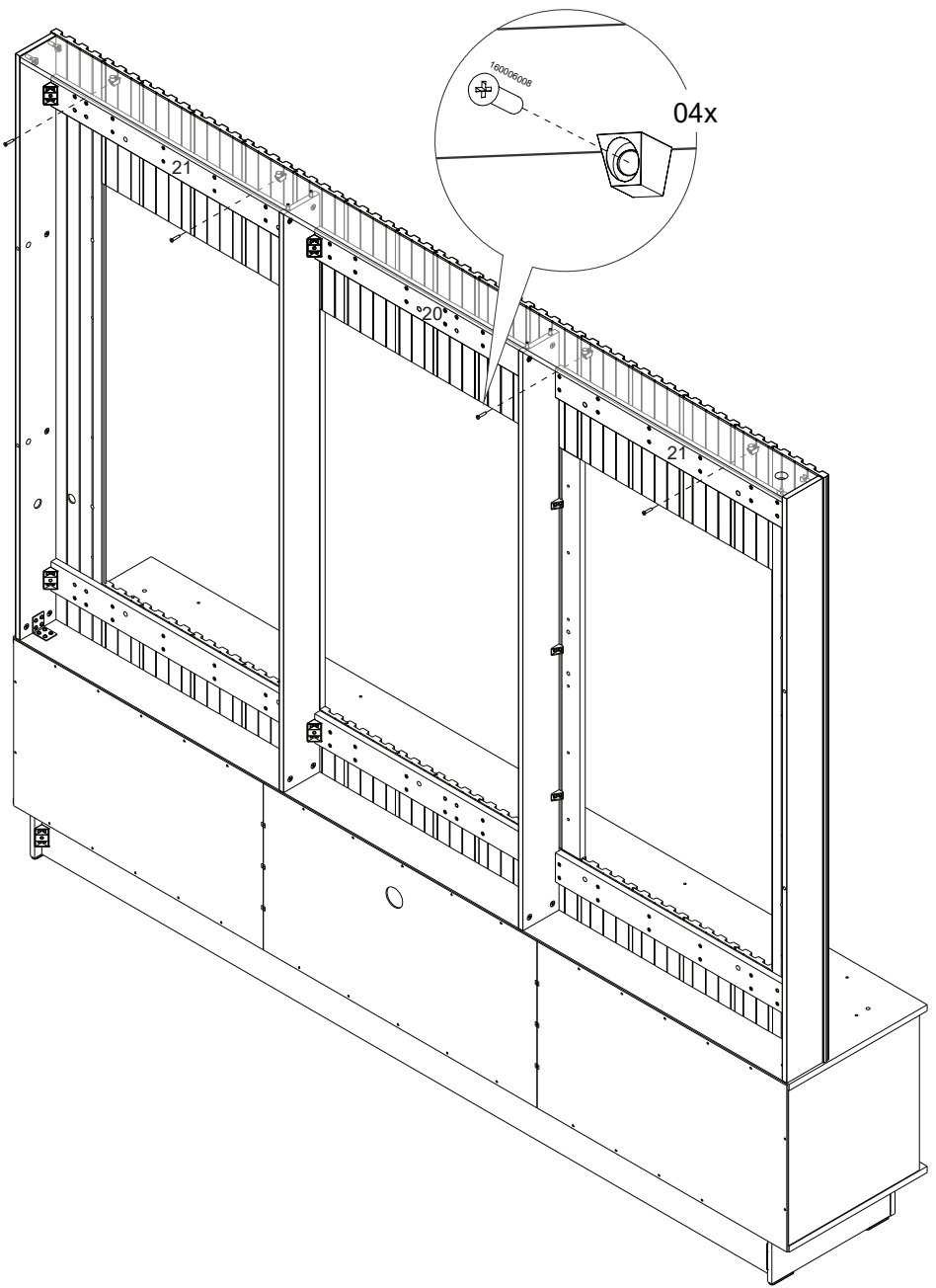
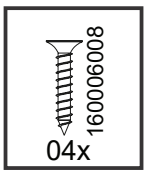

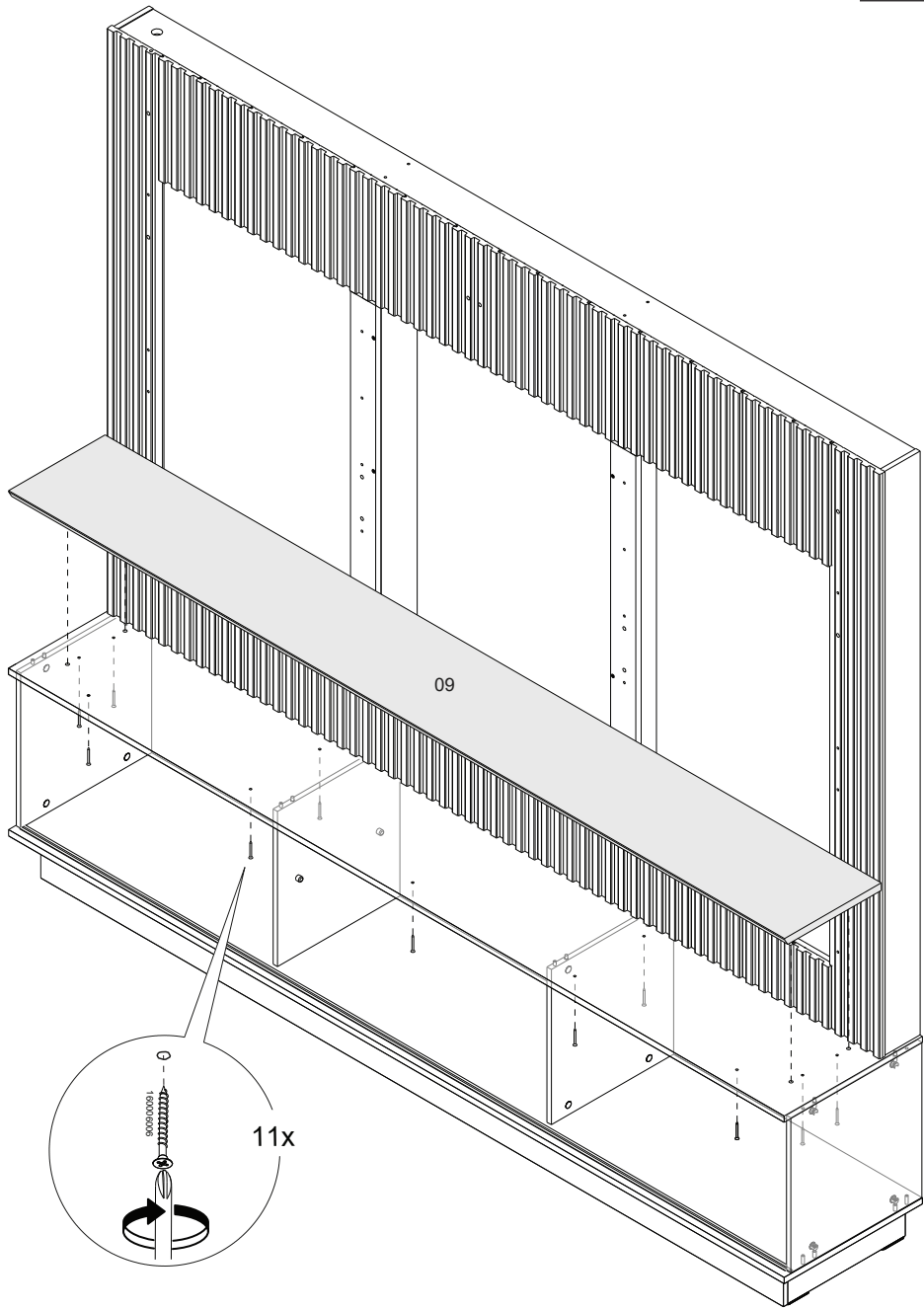
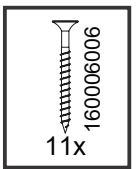



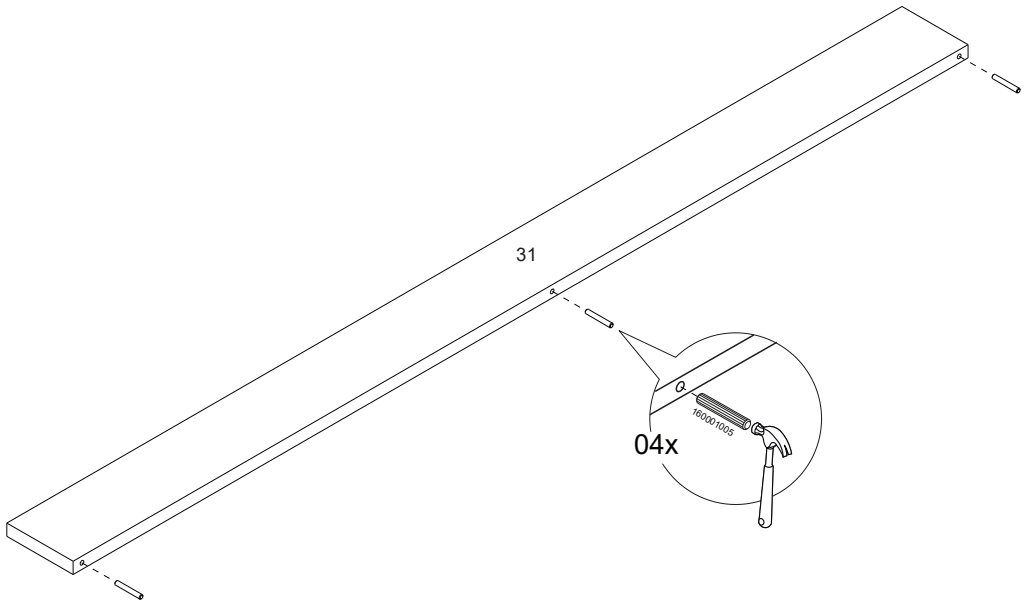
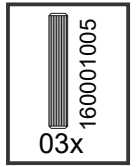

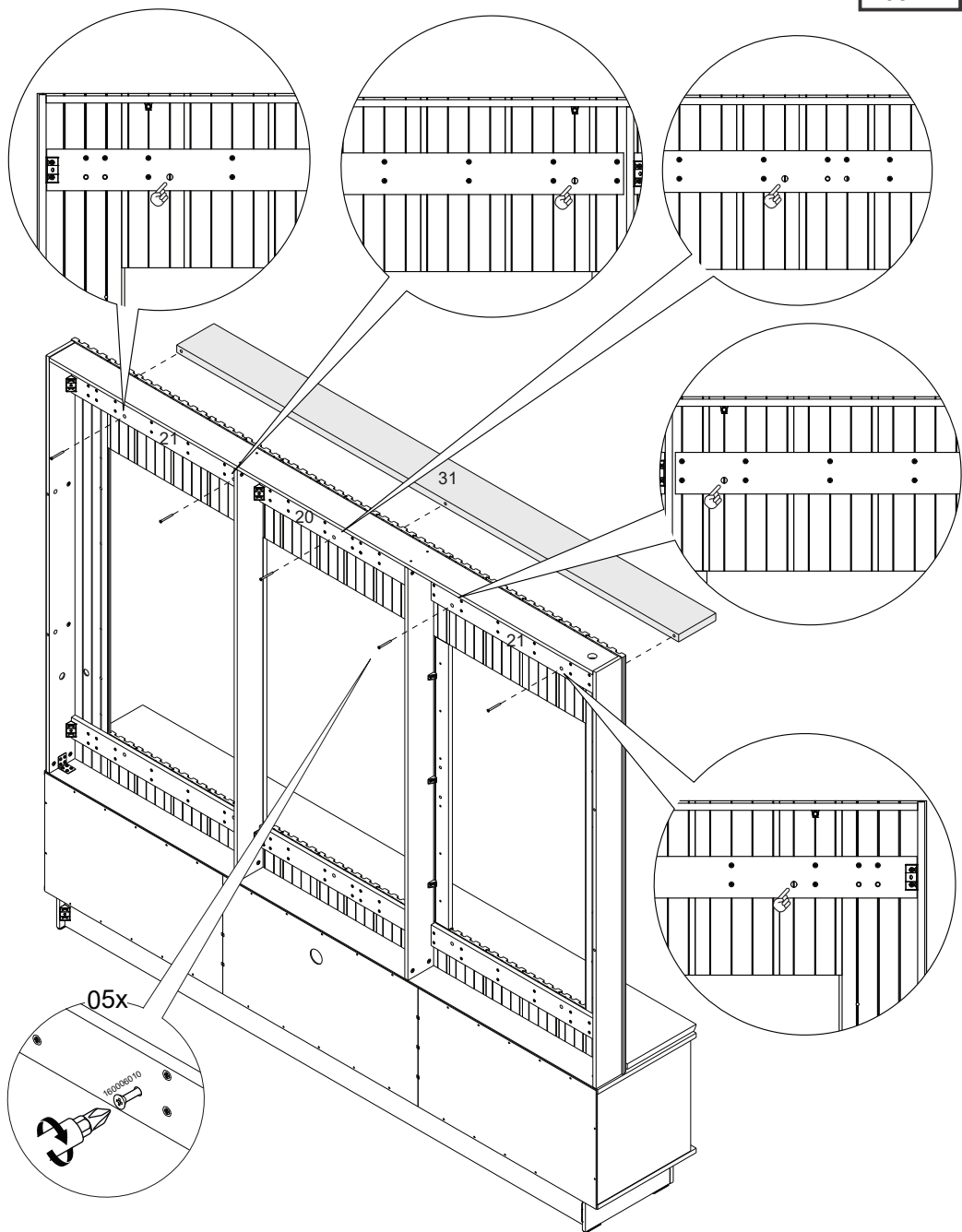
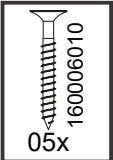
35



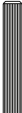

 160006008 06x	 160001005 02x	 160001004 02x
------------------------------------------------------------------------------------------------------	------------------------------------------------------------------------------------------------------	-------------------------------------------------------------------------------------------------------

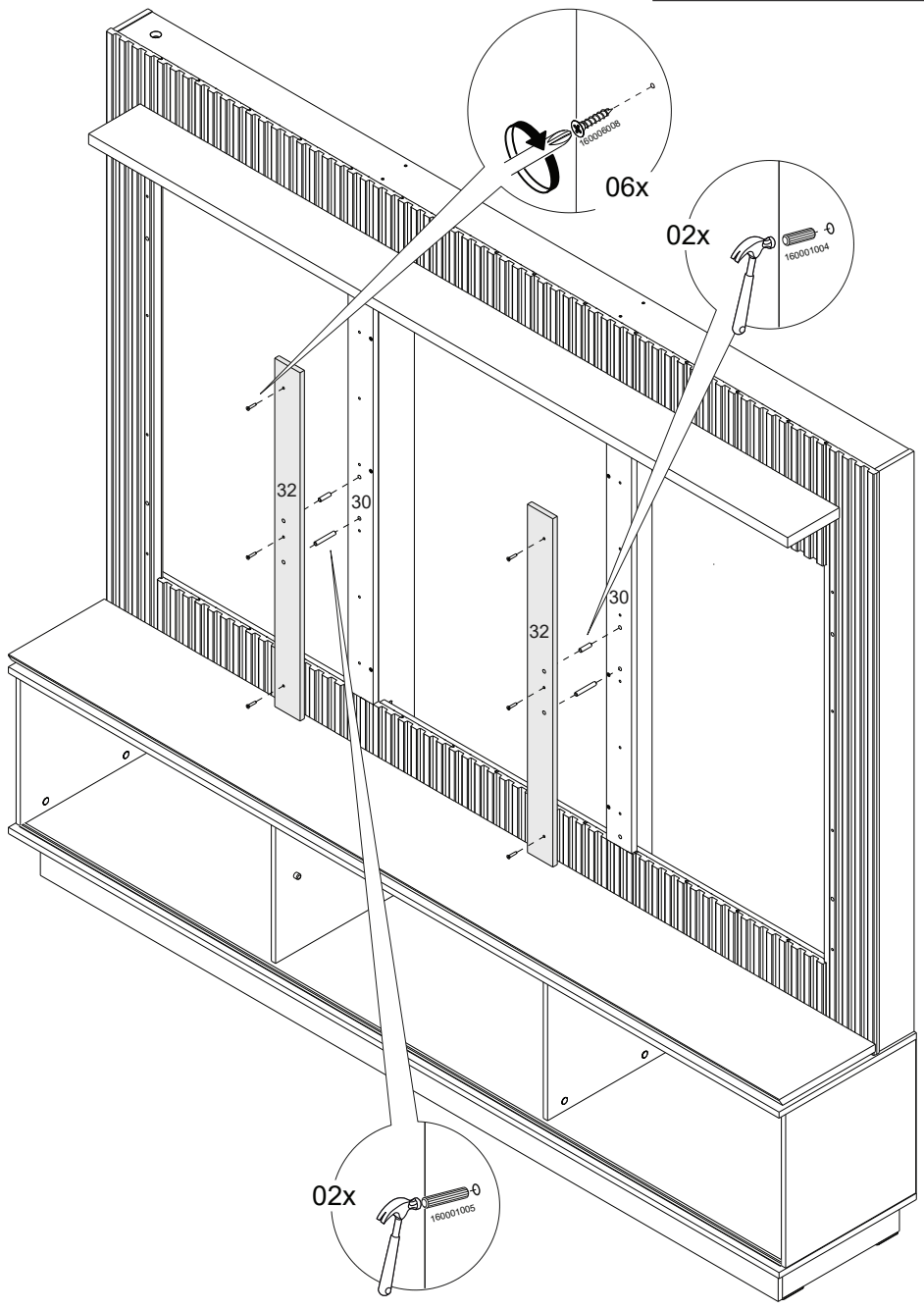

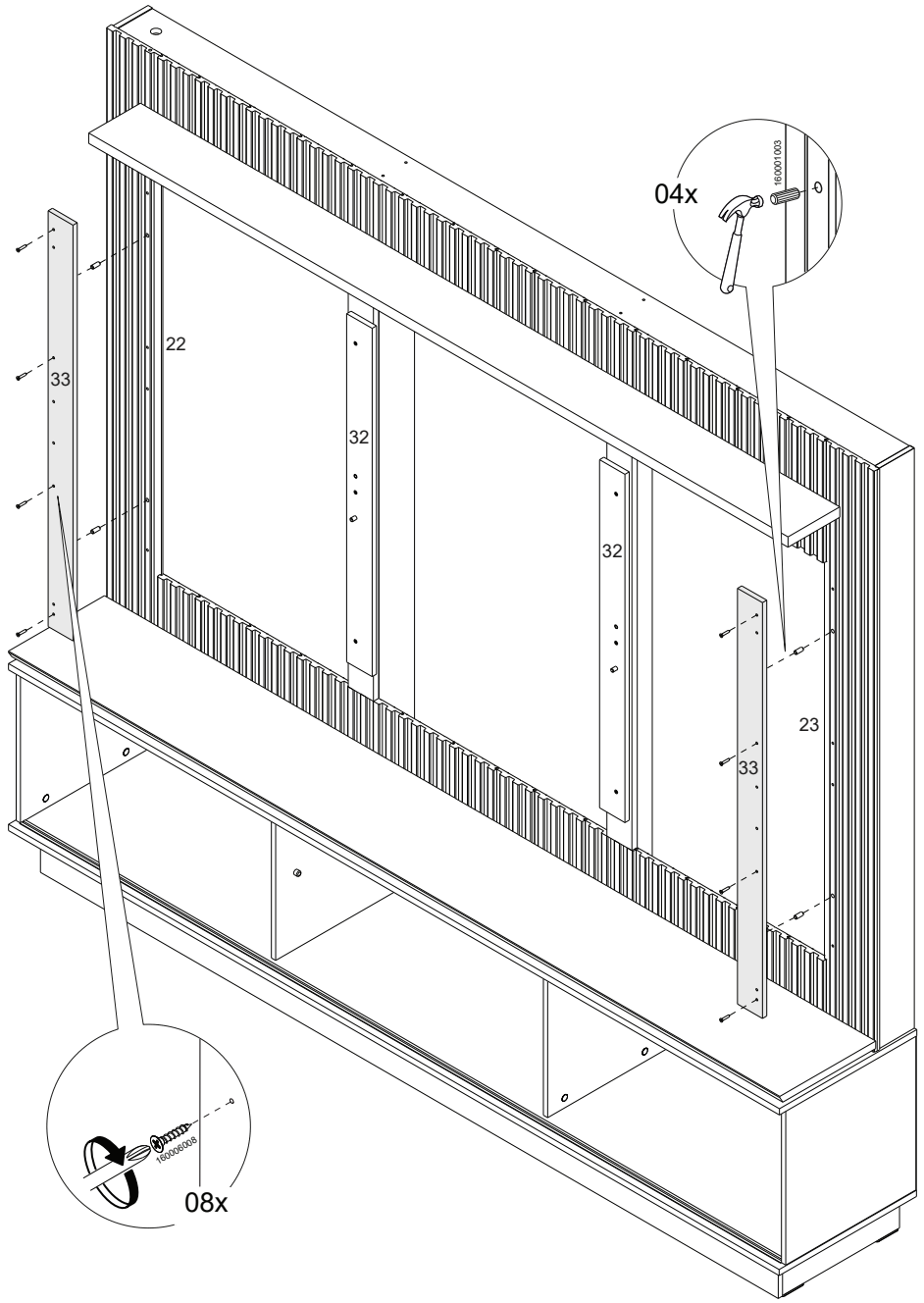
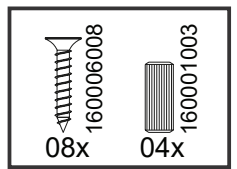

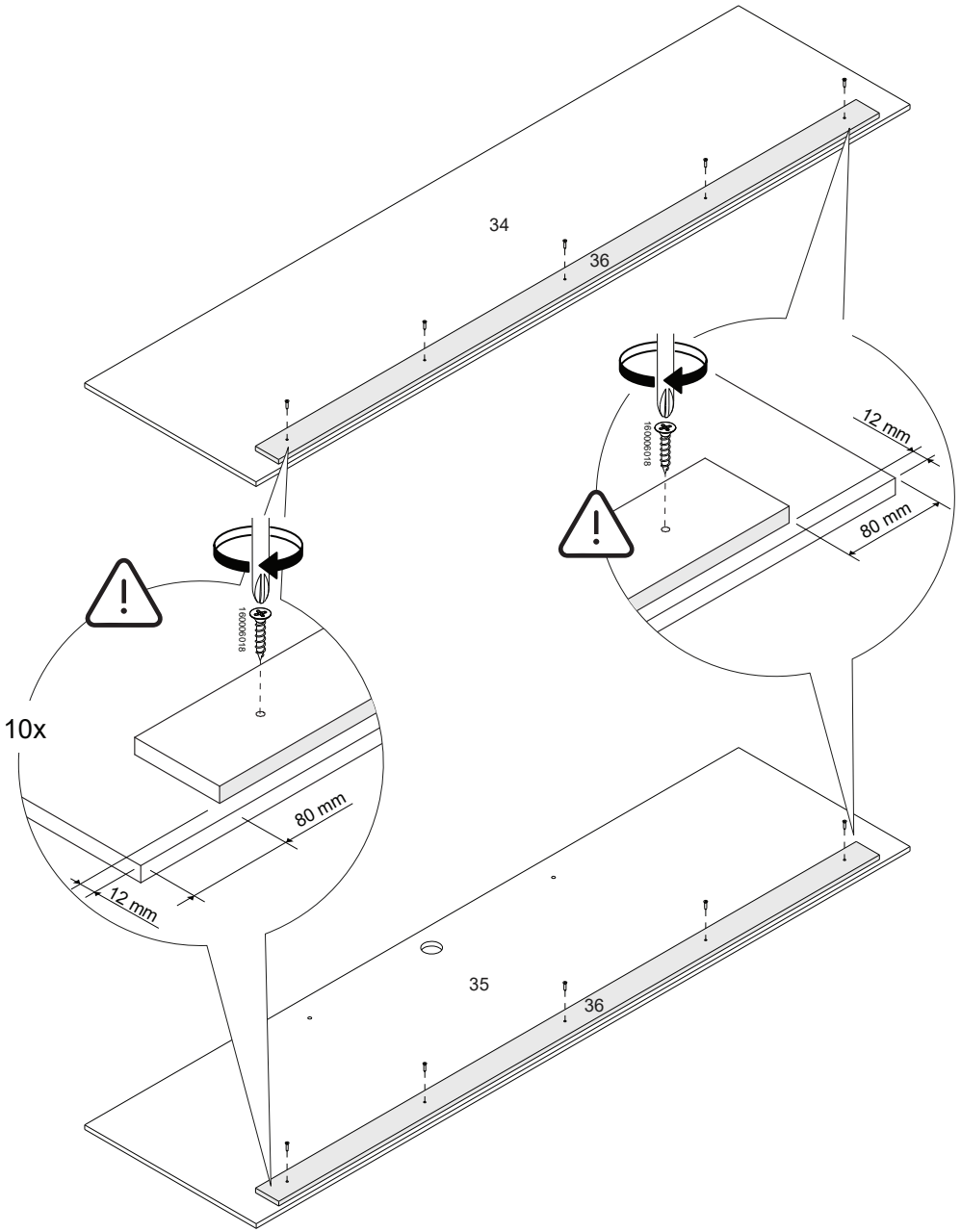
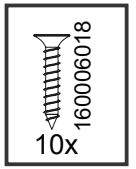

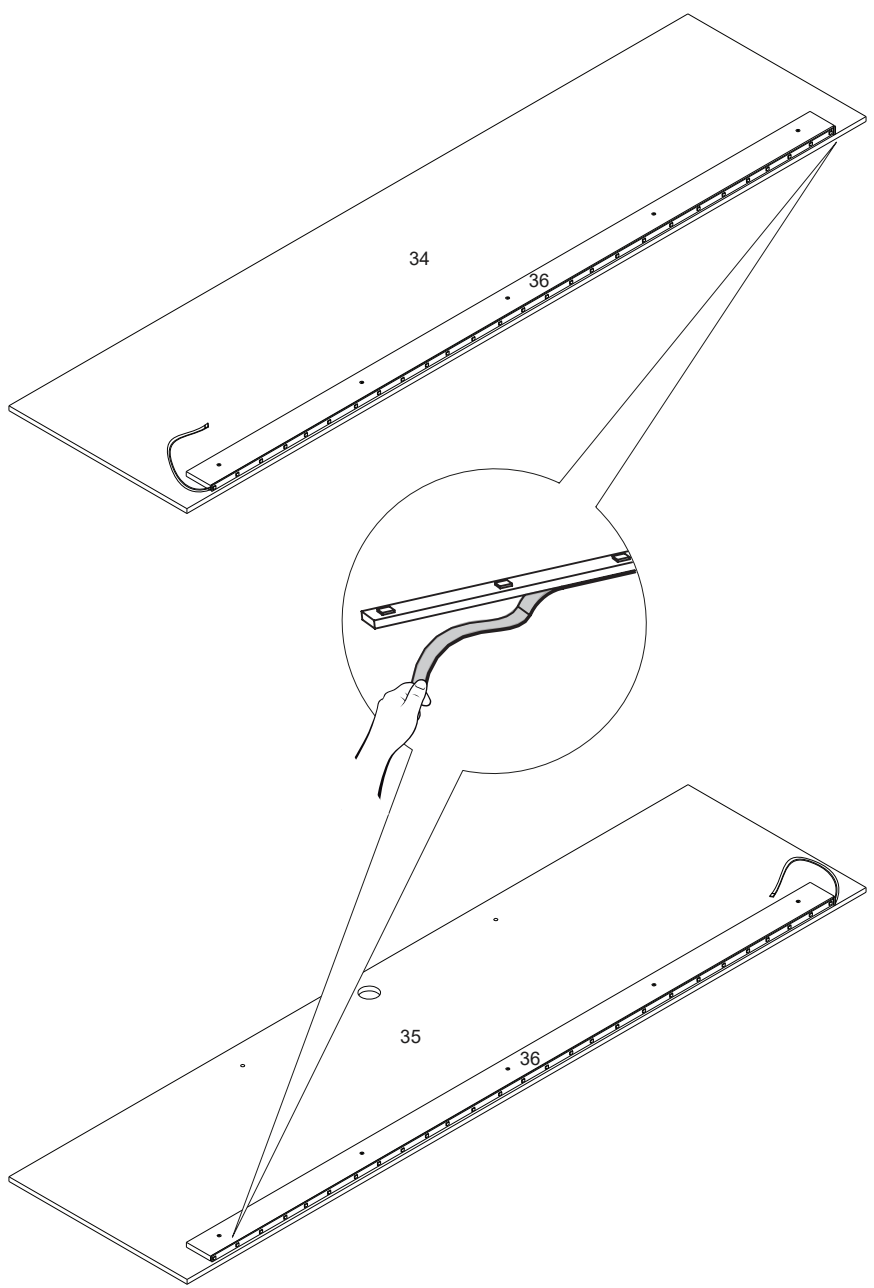
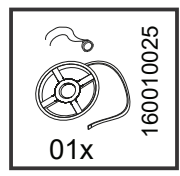

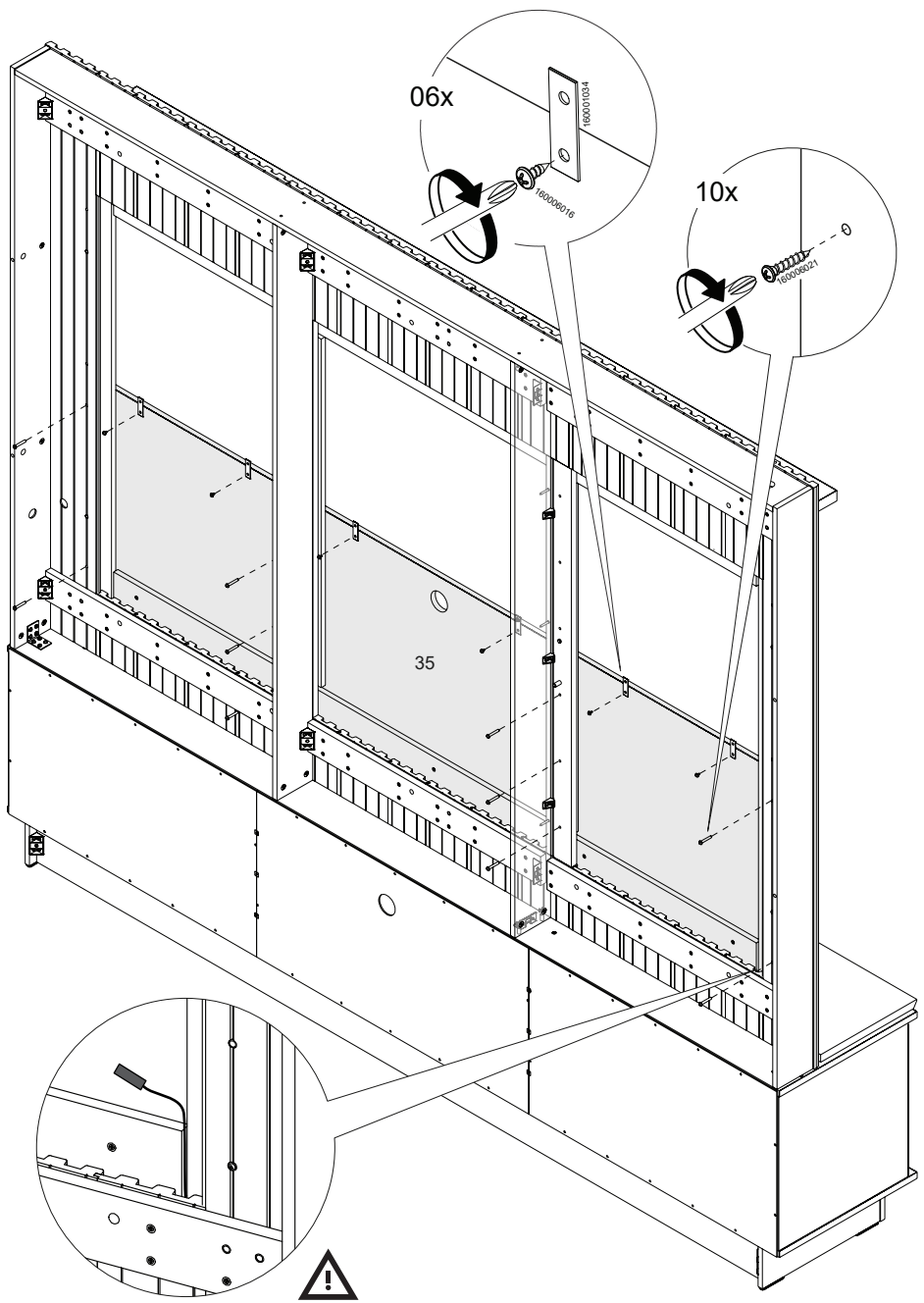
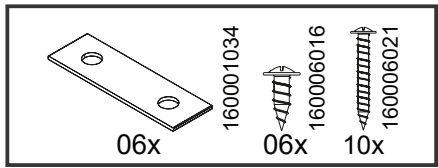



	160006016		160006021
06x		10x	

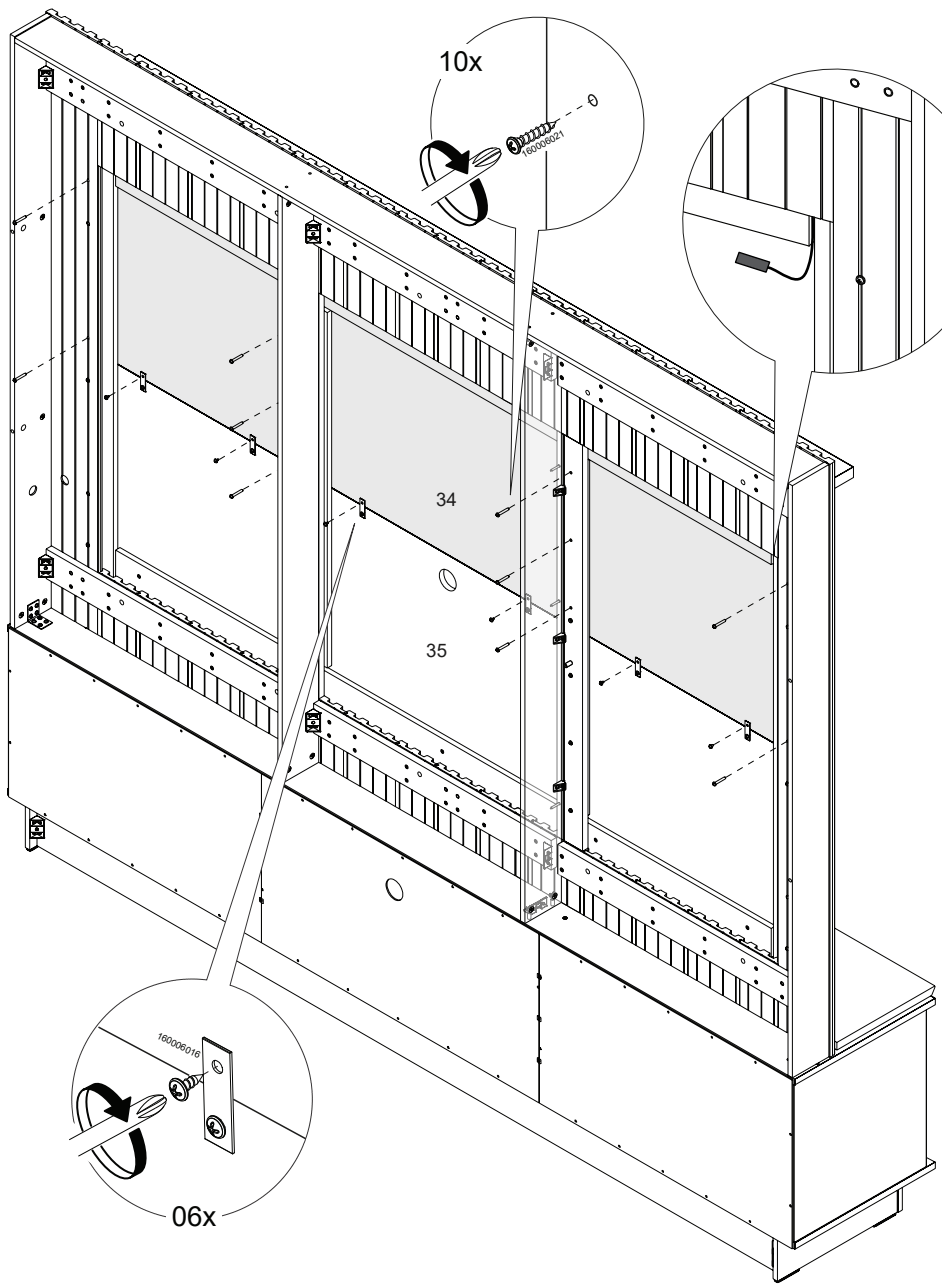

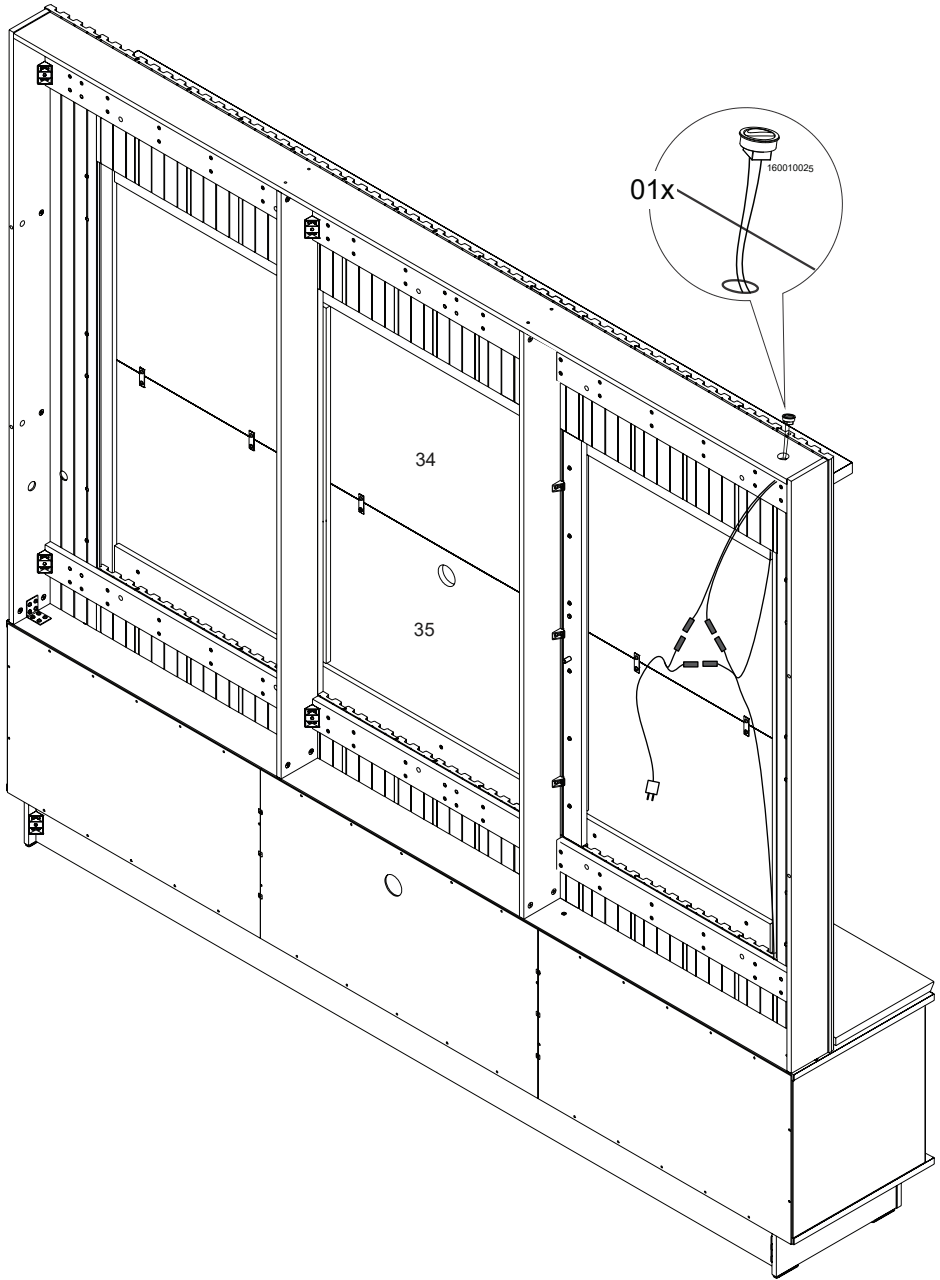
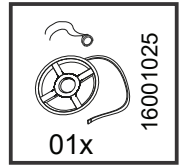

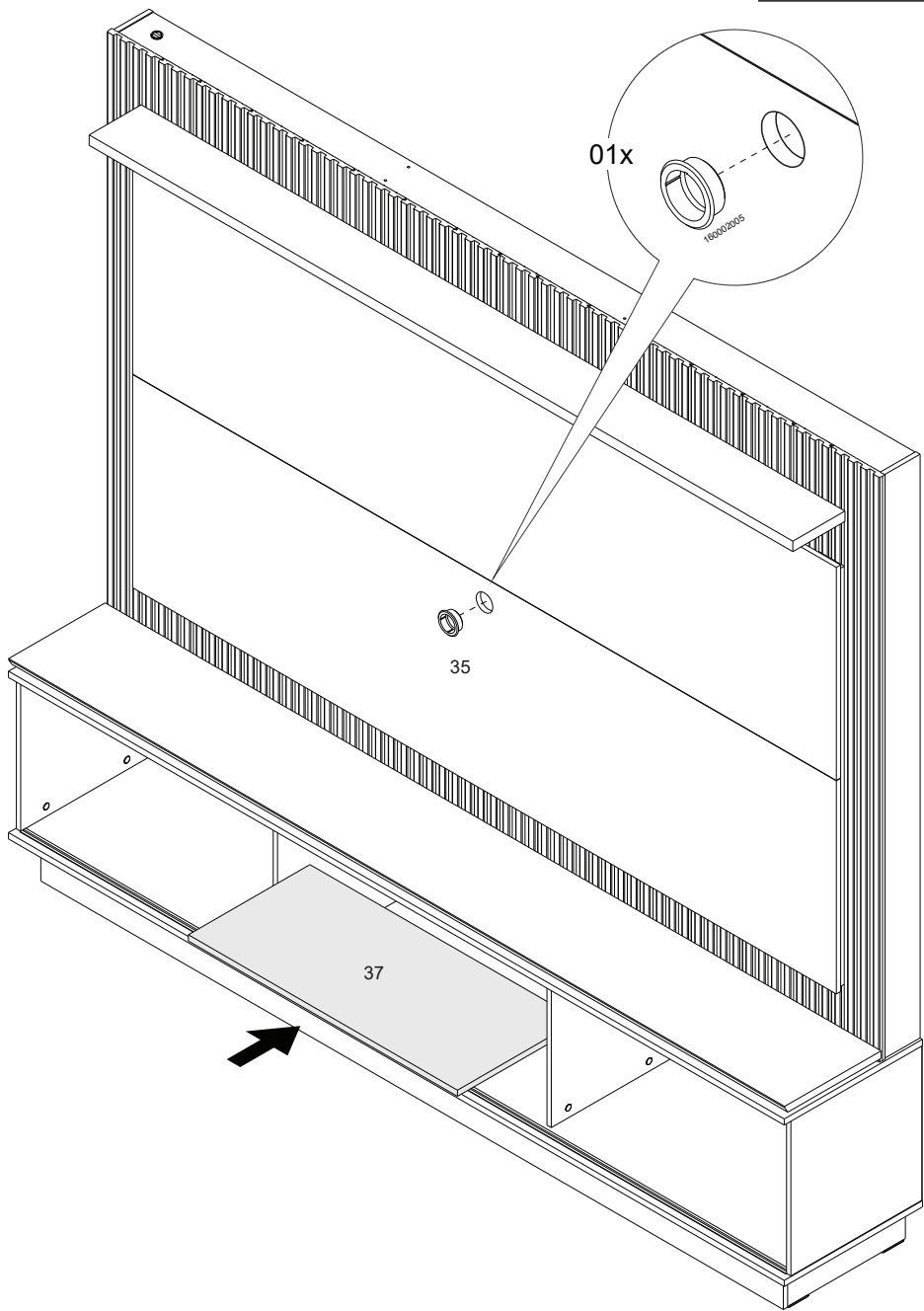
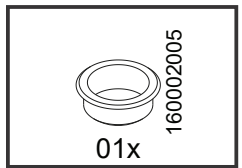

45

- 160006044 01x
- 160005067 01x
- 160002015 02x
- 160003004 02x
- 160003004 02x
- 160003004 10x
- 160003004 1x
- 160006003 01x
- 160003005 01x

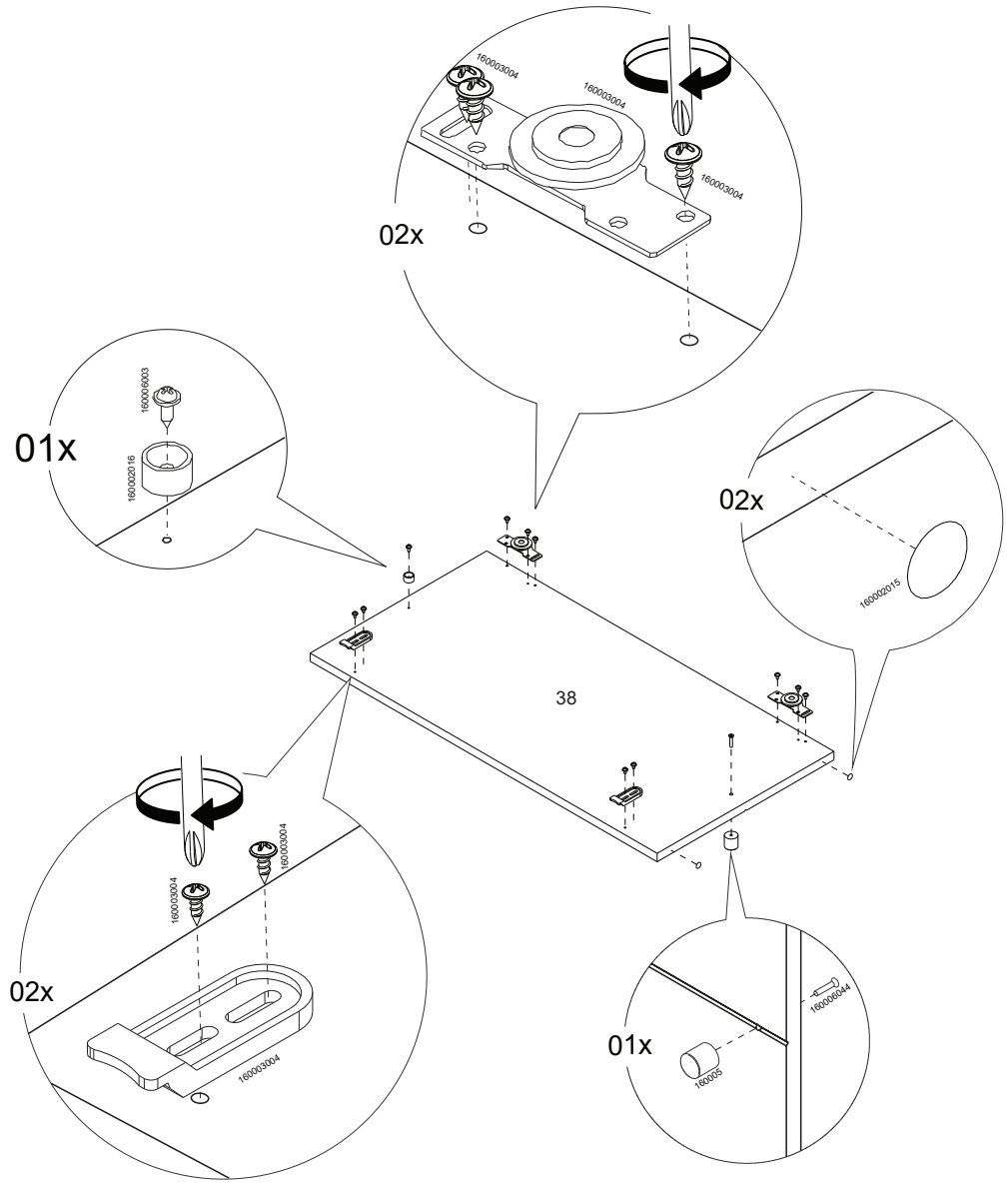

46

- 160006044 01x
- 160005067 01x
- 160002015 02x
- 160003004 02x
- 160003004 02x
- 160003004 10x
- 160003004 1x
- 160006003 01x
- 160003005 01x

