

# MANUAL DE MONTAGEM

## INSTRUCCIONES DE MONTAJE

### ASSEMBLY INSTRUCTIONS

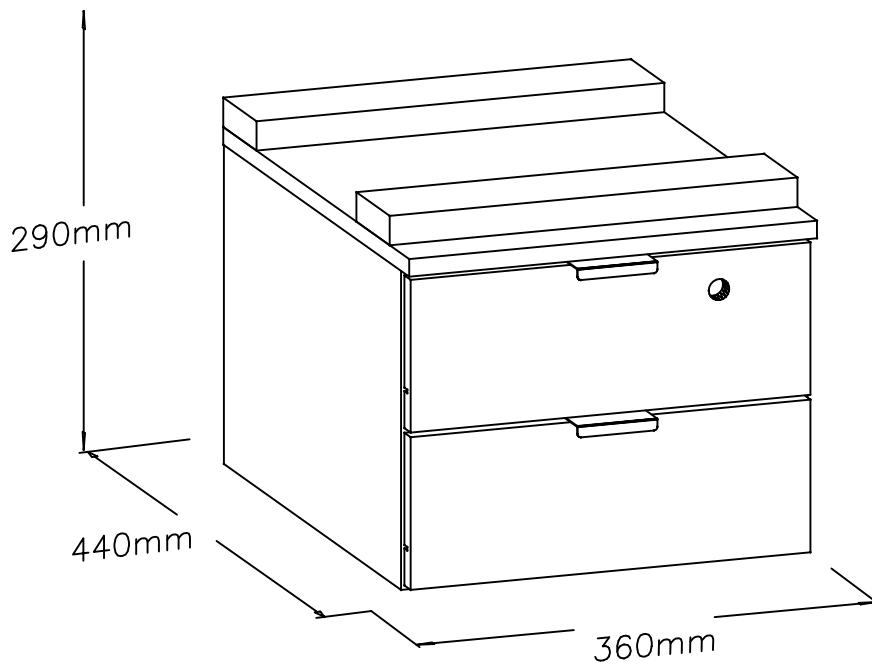

**ATENÇÃO / PRECAUCIÓN / ATTENTION:**

- 1 – Ler atentamente todo o manual antes de iniciar a montagem do móvel.
- 2 – A montagem deve ser feita em uma superfície plana e limpa.
- 3 – Recomenda-se utilizar a embalagem do móvel para forrar e chão e assim não danificá-lo.
  - 1 – Lea cuidadosamente todo el manual antes de comenzar el montaje.
  - 2 – La instalación debe hacerse sobre una superficie plana y limpia.
  - 3 – Recomanda ser utilizado para empaquetar móbil a la línea y tierra y por lo tanto dañar ellos.
- 1 – Read the entire manual carefully before starting the furniture assembly.
- 2 – The assembly must be done on a flat and clean surface.
- 3 – It is recommended to use the packaging of the furniture to cover and floor and thus not to damage them.

**LIMPEZA E CONSERVAÇÃO / LIMPIEZA Y CONSERVACIÓN / CLEANLINESS AND CONSERVATION:**

A limpeza do móvel deve ser feita com utilização de pano umedecido com água, podendo conter uma pequena quantidade de álcool. Não utilize produtos abrasivos.

La unidad de limpieza se debe realizar con el uso de paño humedecido con agua y puede contener una pequeña cantidad de alcohol. No utilice productos abrasivos.

The furniture should be cleaned with a cloth dampened with water and may contain a small amount of alcohol. Do not use abrasive products.

**GARANTIA / GARANTÍA / WARRANTY:**

90 dias para defeitos de fabricação.

90 días a defectos de fabricación.

90 days for manufacturing defects.

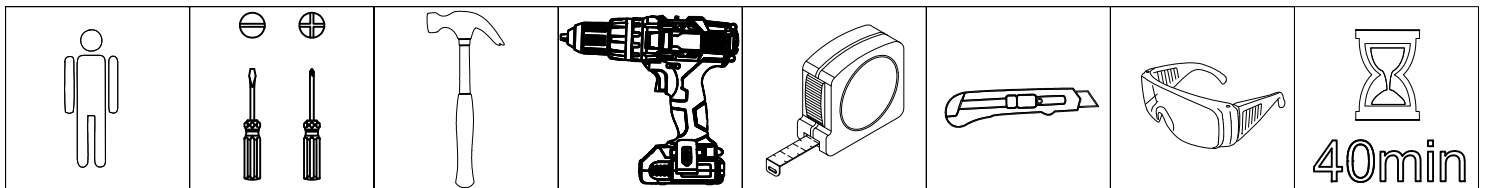
**FERRAMENTAS NECESSÁRIAS / HERRAMIENTAS NECESARIAS / TOOLS REQUIRED:**

Acesse as dicas de  
montagem no Youtube

Accede a los consejos de  
montaje en Youtube.

Access the mounting tips on  
Youtube.







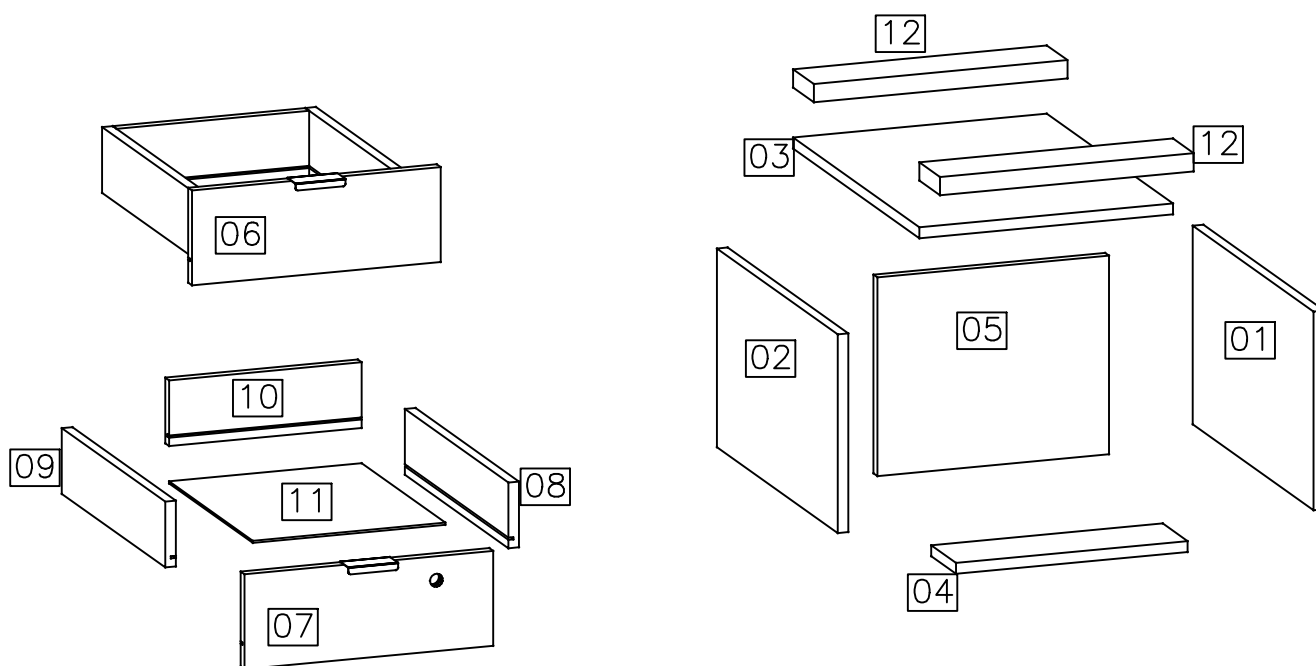

[www.youtube.com/MoveisKappesberg](http://www.youtube.com/MoveisKappesberg)

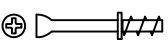

## Lista de peças / Lista de piezas / List of pieces

Código/ Código/ Code	Descrição	Descripción	Description	Quantidade/ Cantidad/ Amount	Comprimento/ Longitud/ Length (mm)	Largura/ Ancho/ Width (mm)	Espessura/ Espesor/ Thickness (mm)	Caixa/ Caja/ Box
01	Lateral direita	Lateral derecha	Right side	1	272	426	15	A
02	Lateral esquerda	Lateral izquierda	Left side	1	272	426	15	A
03	Tampo	Pieza superior	Top piece	1	357	447	15	A
04	Base	Pieza de suelo	Base	1	326	96	15	A
05	Costas	Pieza del fondo	Back panel	1	272	326	15	A
06	Frente de gaveta superior	Frente de cajón superior	Top front drawer	1	350	130	15	A
07	Frente de gaveta inferior	Frente de cajón inferior	Lower front drawer	1	350	130	15	A
08	Lateral de gaveta dir.	Lateral de cajón derecha	Right drawer side	2	400	90	15	A
09	Lateral de gaveta esq.	Lateral de cajón izquierda	Left drawer side	2	400	90	15	A
10	Cabeceira de gaveta	Cabecera de cajón	Back drawer	2	271	90	15	A
11	Fundo de gaveta	Fondo de cajón	Bottom drawer	2	284	398	3	A
12	Sarrafo superior	Marco superior	Upper slat	2	357	80	25	A

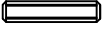
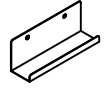
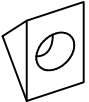

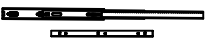
Ferragem / Herrajes / Hardware			
	Código/ Código/ Code	Descrição / Descripción / Description	Quan./ Cant./ Amou.
A	51980	 Parafuso/ Tornillo/ Screw 4,5x50	8
B	10568	 Parafuso/ Tornillo/ Screw 4x35	4
C	30945	 Parafuso Minifix/ Tornillo/Connecting Bolt	14
D	30950	 Tambor Minifix/Cilindro/Minifix Cam	14
E	4214	 Parafuso/ Tornillo/ Screw 3,5x14	32
F	5256	 Parafuso/ Tornillo/ Screw 4x20	4
G	1802	 Cavilha/Tarugo/Dowel 6x30mm	18
H	39999	 Puxador de chapa J/Asar/Handle Preto fosco	2
I	18458	 Suporte triangular preto/Soporte triangular negro/Black triangular support	4
J	58	 Etiqueta marca/Tag label "Kappesberg"	1
K	41	 Cola branca em bisnaga/Cola blanca/White glue (10g)	1
L	38305	 Trilho telescópico mini light/Corredera de metal/Metal slide 400mm	2

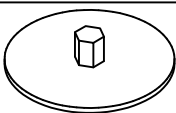
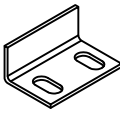
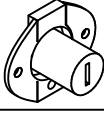
M	14855		Tampa para minifix/Tapa del agujero/Screw cap cover Carvalle	14
N	1622		"L" de engate/Kit de cerradura/Lock kit	1
O	1620		Fechadura com chave/Cerradura puerta/Door lock	1
01 Saco pequeno para acessórios				
01 Saco pequeno para puxadores				



2X

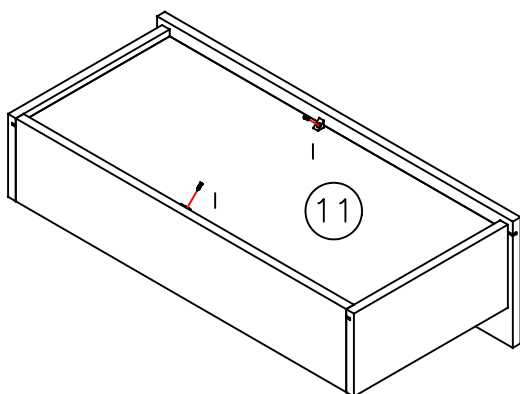
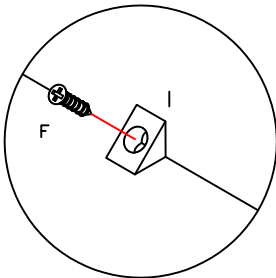
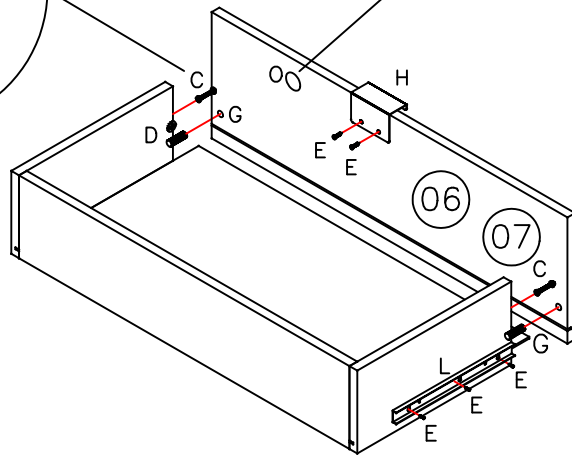
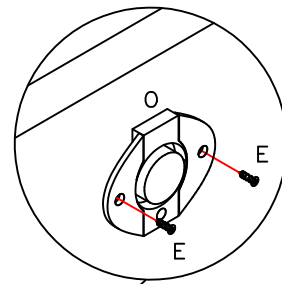
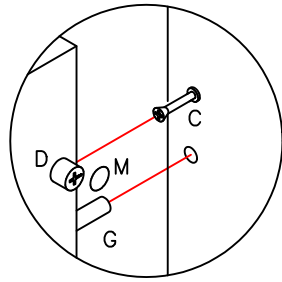
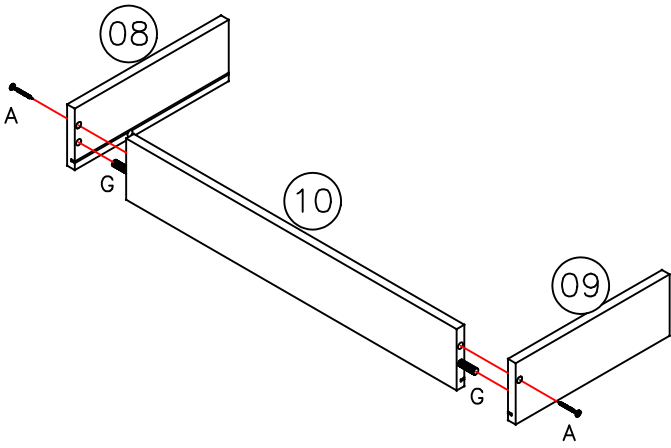

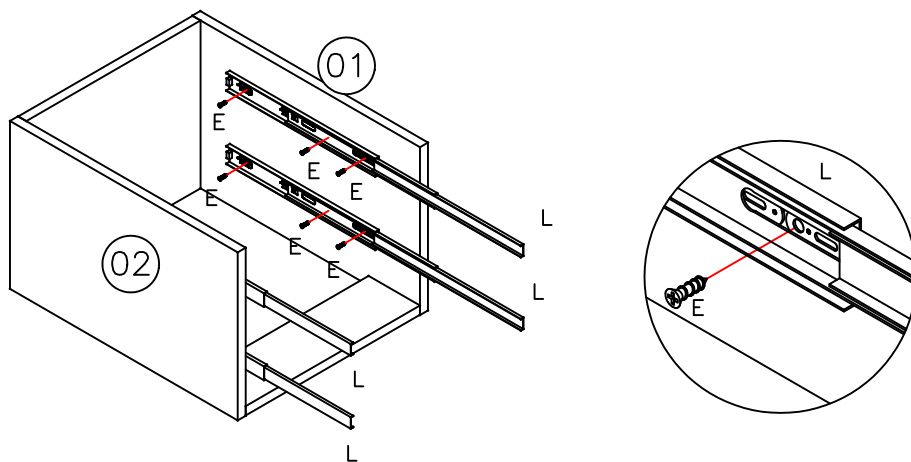
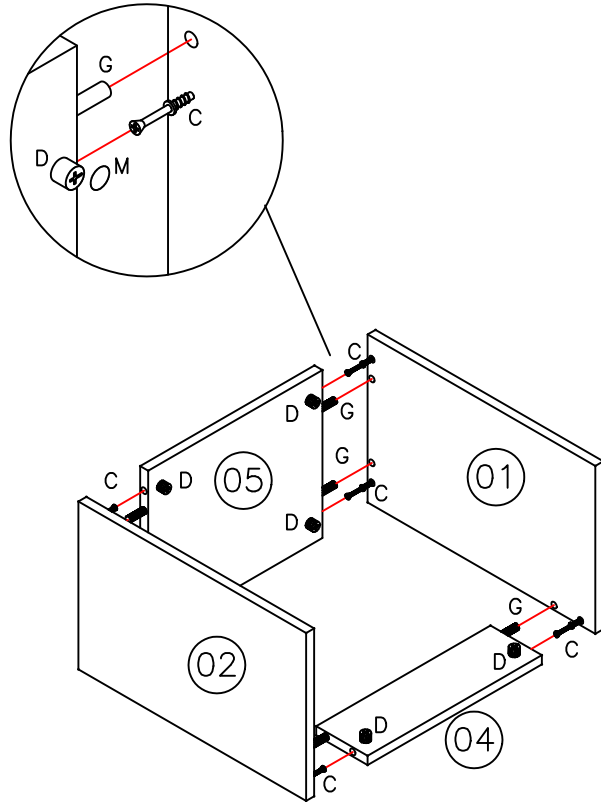

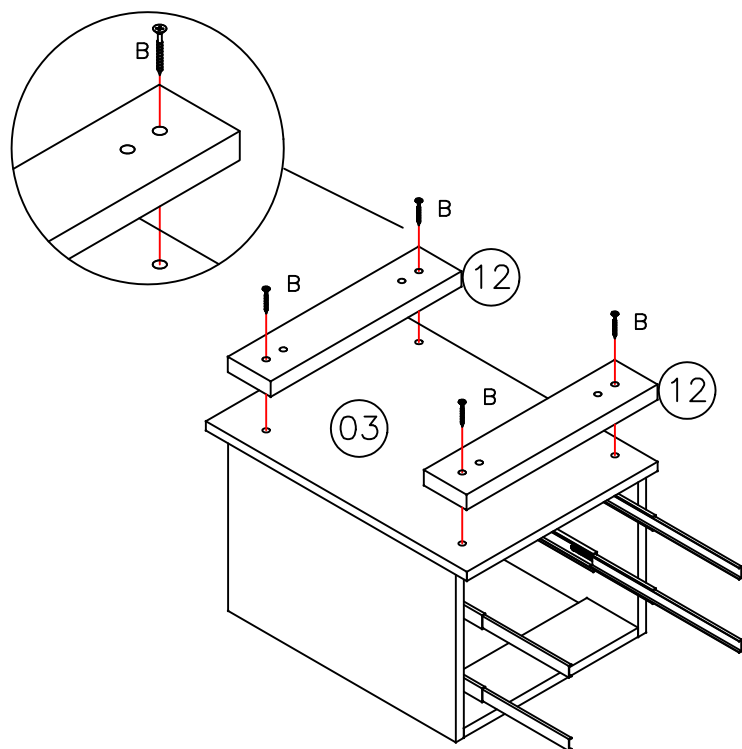
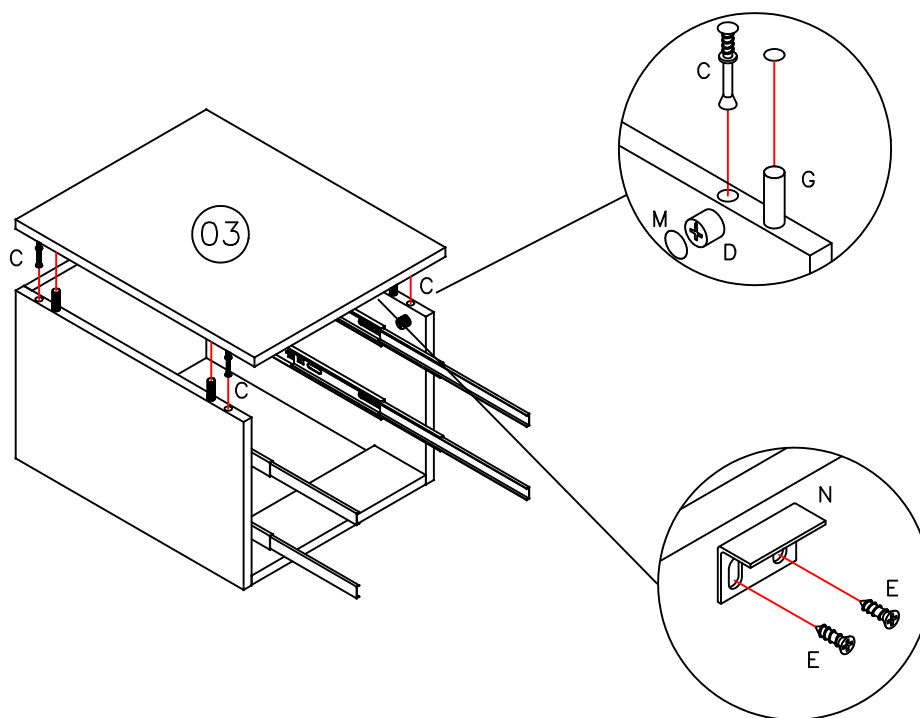

–Use a opção de perfuração do lado externo para prender a o sarrafo superior (12)

–Utilice la opción de perforación exterior para asegurar el listón superior (12)

–Use the outside drilling option to secure the upper batten (12)



–Para que haja um bom desempenho das gavetas, é necessário que os parafusos frontais “A” sejam fixados junto com a ripa inferior do tampo

–Para que los cajones funcionen correctamente es necesario que los tornillos frontales “A” se fijen junto con la tira inferior del banco.

–For a good performance of the drawers, it is necessary that the front screws “A” are fixed together with the lower lath of the worktop

