

MANUAL DE MONTAGEM

INSTRUCCIONES DE MONTAJE

ASSEMBLY INSTRUCTIONS

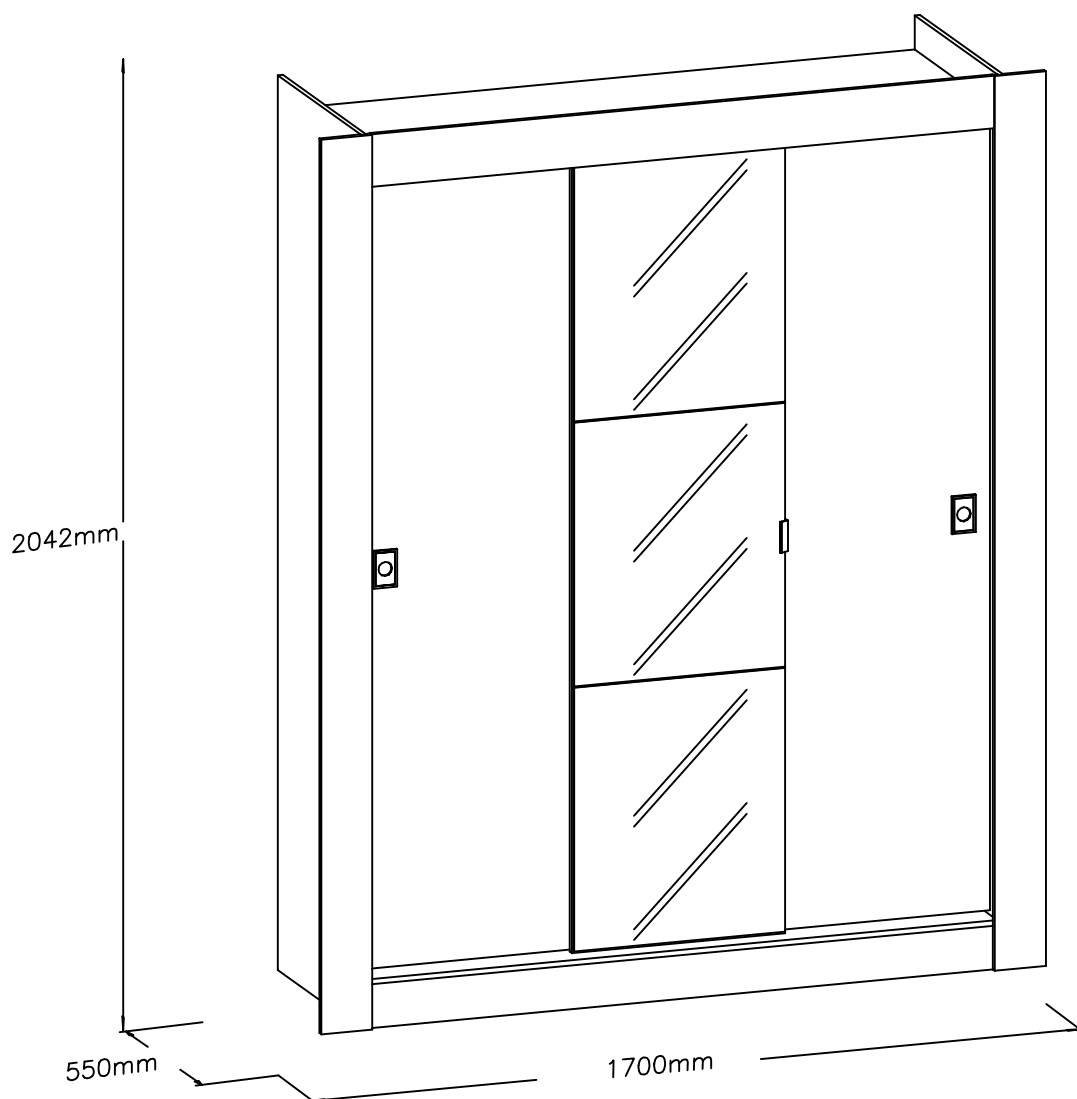

ATENÇÃO / PRECAUCIÓN / ATTENTION:

- 1 – Ler atentamente todo o manual antes de iniciar a montagem do móvel.
- 2 – A montagem deve ser feita em uma superfície plana e limpa.
- 3 – Recomenda-se utilizar a embalagem do móvel para forrar e chão e assim não danificá-lo.
 - 1 – Lea cuidadosamente todo el manual antes de comenzar el montaje.
 - 2 – La instalación debe hacerse sobre una superficie plana y limpia.
 - 3 – Recomanda ser utilizado para empaquetar móvil a la línea y tierra y por lo tanto dañar ellos.
- 1 – Read the entire manual carefully before starting the furniture assembly.
- 2 – The assembly must be done on a flat and clean surface.
- 3 – It is recommended to use the packaging of the furniture to cover and floor and thus not to damage them.

LIMPEZA E CONSERVAÇÃO / LIMPIEZA Y CONSERVACIÓN / CLEANLINESS AND CONSERVATION:

A limpeza do móvel deve ser feita com utilização de pano umedecido com água, podendo conter uma pequena quantidade de álcool. Não utilize produtos abrasivos.

La unidad de limpieza se debe realizar con el uso de paño humedecido con agua y puede contener una pequeña cantidad de alcohol. No utilice productos abrasivos.

The furniture should be cleaned with a cloth dampened with water and may contain a small amount of alcohol. Do not use abrasive products.

GARANTIA / GARANTÍA / WARRANTY:

90 dias para defeitos de fabricação.

90 días a defectos de fabricación.

90 days for manufacturing defects.

FERRAMENTAS NECESSÁRIAS / HERRAMIENTAS NECESARIAS / TOOLS REQUIRED:

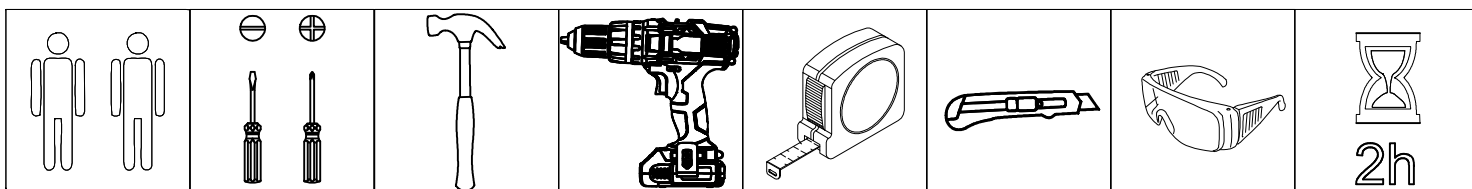

Acesse as dicas de
montagem no Youtube

Accede a los consejos de
montaje en Youtube.

Access the mounting tips on
Youtube.









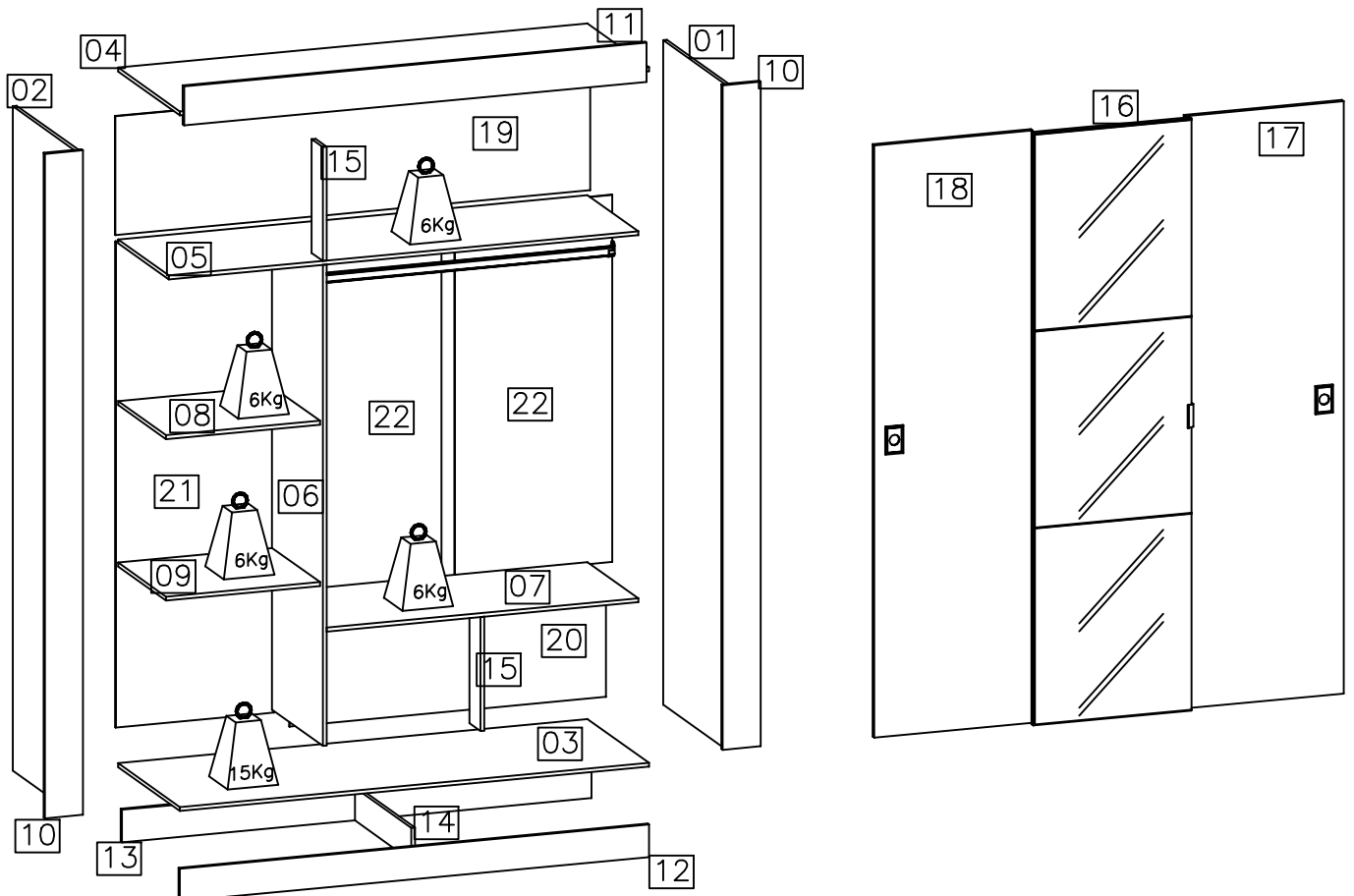

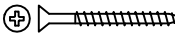

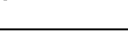
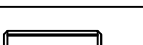





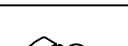



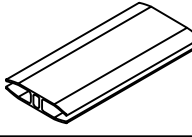
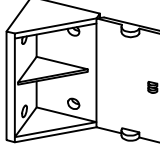

www.youtube.com/MoveisKappesberg

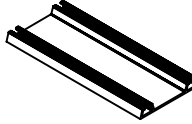

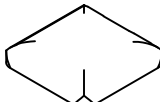
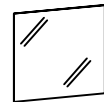
Lista de peças / Lista de piezas / List of pieces

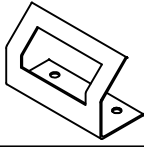
Código/ Código/ Code	Descrição	Descripción	Description	Quantidade/ Cantidad/ Amount	Comprimento / Longitud/ Length (mm)	Largura/ Ancho/ Width (mm)	Espessura/ Espesor/ Thickness (mm)	Caixa/ Caja/ Box																																																																																
01	Lateral direita	Lateral derecha	Right side	1	2042	540	12	A																																																																																
02	Lateral esquerda	Lateral izquierda	Left side	1	2042	540	12	A																																																																																
03	Base	Pieza de suelo	Base	1	1482	535	12	A																																																																																
04	Chapéu	Pieza de techo	Top	1	1482	535	12	A																																																																																
05	Base do maleiro	Base superior	Upper base	1	1482	442	12	B																																																																																
06	Divisória	División	Division	1	1478	440	12	B																																																																																
07	Prateleira maior	Estantería mayor	Shelf larger	1	984	440	12	B																																																																																
08	Prateleira menor fixa	Estantería pequeña fijo	Fixed smaller shelf	1	486	440	12	A																																																																																
09	Prateleiras menor solta	Estantería pequeña suelta	Loose smaller shelf	1	486	440	12	A																																																																																
10	Sarrafo lateral	Marco lateral	Side slat	2	2042	120	12	A																																																																																
11	Sarrafo superior	Marco superior	Higher slat	1	1460	120	12	A																																																																																
12	Rodapé frontal	Zócalo de frente	Frontal baseboard	1	1482	100	12	A																																																																																
13	Rodapé traseiro	Zócalo trasero	Back baseboard	1	1482	100	12 </tr <tr> <td>14</td> <td>Rodapé interno</td> <td>Zócalo interno</td> <td>Internal baseboard</td> <td>1</td> <td>489</td> <td>100</td> <td>12</td> <td>A</td> </tr> <tr> <td>15</td> <td>Pilastra</td> <td>Pilastra</td> <td>Pillar</td> <td>2</td> <td>350</td> <td>96</td> <td>12</td> <td>A</td> </tr> <tr> <td>16</td> <td>Portas central</td> <td>Puerta centrales</td> <td>Central door</td> <td>1</td> <td>1820</td> <td>500</td> <td>15</td> <td>B</td> </tr> <tr> <td>17</td> <td>Porta direita</td> <td>Puerta derecha</td> <td>Right door</td> <td>1</td> <td>1820</td> <td>500</td> <td>15</td> <td>B</td> </tr> <tr> <td>18</td> <td>Porta esquerda</td> <td>Puerta izquierda</td> <td>Left door</td> <td>1</td> <td>1820</td> <td>500</td> <td>15</td> <td>B</td> </tr> <tr> <td>19</td> <td>Costa do maleiro</td> <td>Pieza del fondo superior</td> <td>Top back panel</td> <td>1</td> <td>1500</td> <td>365</td> <td>3</td> <td>B</td> </tr> <tr> <td>20</td> <td>Costa inferior</td> <td>Pieza inferior del fondo</td> <td>Lower bottom part</td> <td>1</td> <td>1000</td> <td>365</td> <td>3</td> <td>B</td> </tr> <tr> <td>21</td> <td>Costa maior</td> <td>Pieza mayor del fondo</td> <td>Bottom larger</td> <td>1</td> <td>1493</td> <td>498</td> <td>3</td> <td>B</td> </tr> <tr> <td>22</td> <td>Costa central</td> <td>Pieza del fondo central</td> <td>Back central panel</td> <td>2</td> <td>1128</td> <td>498</td> <td>3</td> <td>B</td> </tr>	14	Rodapé interno	Zócalo interno	Internal baseboard	1	489	100	12	A	15	Pilastra	Pilastra	Pillar	2	350	96	12	A	16	Portas central	Puerta centrales	Central door	1	1820	500	15	B	17	Porta direita	Puerta derecha	Right door	1	1820	500	15	B	18	Porta esquerda	Puerta izquierda	Left door	1	1820	500	15	B	19	Costa do maleiro	Pieza del fondo superior	Top back panel	1	1500	365	3	B	20	Costa inferior	Pieza inferior del fondo	Lower bottom part	1	1000	365	3	B	21	Costa maior	Pieza mayor del fondo	Bottom larger	1	1493	498	3	B	22	Costa central	Pieza del fondo central	Back central panel	2	1128	498	3	B
14	Rodapé interno	Zócalo interno	Internal baseboard	1	489	100	12	A																																																																																
15	Pilastra	Pilastra	Pillar	2	350	96	12	A																																																																																
16	Portas central	Puerta centrales	Central door	1	1820	500	15	B																																																																																
17	Porta direita	Puerta derecha	Right door	1	1820	500	15	B																																																																																
18	Porta esquerda	Puerta izquierda	Left door	1	1820	500	15	B																																																																																
19	Costa do maleiro	Pieza del fondo superior	Top back panel	1	1500	365	3	B																																																																																
20	Costa inferior	Pieza inferior del fondo	Lower bottom part	1	1000	365	3	B																																																																																
21	Costa maior	Pieza mayor del fondo	Bottom larger	1	1493	498	3	B																																																																																
22	Costa central	Pieza del fondo central	Back central panel	2	1128	498	3	B																																																																																



Ferragem / Herrajes / Hardware				
	Código/ Código/ Code	Descrição / Descripción / Description	Quan./ Cant./ Amou.	
A	226	 Parafuso/ Tornillo/ Screw 4x40	32	
B	30457	 Parafuso/ Tornillo/ Screw 3,5x12	70	
C	107	 Prego/Clavo/Nail 10x10	107	
D	108	 Prego/Clavo/Nail 12x12	8	
E	1925	 Cavilha/Tarugo/Pe g 6x50mm	1	
F	1802	 Cavilha/Tarugo/Pe g 6x30mm	16	
G	85	 "L" de metal/Cantón "L" de metal/Metal angle bracket "L"	2	
H	899	 Cantoneira de metal/Cantón de metal/Metal angle bracket	6	
I	118	 Suporte para prateleira/Soporte de estante/Shelf support	4	
J	49485	 Rolete sem regulagem/Pieza sin regulaciones/Roller	6	
K	49485	 Guia com mola /Guía del puerta/Guide the door	6	
L	49485	 Parafuso flange/ Tornillo/ Screw 3,5x14 ZB	36	
M	41921	 Suporte cabideiro metal/Soporte percha/Clothes rack	2	
N	1423	 Fixador de costa/Fijador de costa/Shore Fixer	40	
O	BR=45292 (Branco liso) JA=44674 (Jacaranda) NO=44741 (Nogal)	 Tapa furo/Tapa del agujero/Tap hole 19mm	26	
P	BR=8010 (Branco liso) JA=44669 (Jacaranda) NO=40736 (Nogal)	 Tapa furo/Tapa del agujero/Tap hole 13mm	32	
Q	1901	 Sapata deslizadora preta/Zapata negra/Shoe black	8	
R	BR=44425 (Branco) JA=44418 (Preto) NO=44421 (Carvalle)	 Perfil H/Perfil de acabado/Finishing profile 1120mm	1	
S	BR=7373 (Branca) JA/NO =7374 (Preta)	 Cantoneira plástica com capa/Cantonera plástica con tapa/Plastic ledge with cover	9	
T	41	 Cola branca em bisnaga/Cola blanca/White glue (10g)	1	
U	58	 Etiqueta marca/Tag label "Kappesberg"	1	
V	47583	 Trilho de alumínio/Carril del aluminio/Rail aluminium 1481mm	2	
W	BR=22972 (Branco) JA/NO= 22973 (Carvalle)	 Porca cilíndrica/pieza cilíndrica/piece cylindrical 12x9mm	32	
X	40534	 Silicone/Silicona/ Selecone 10x10	12	
Y	47587	 Espelho/Espejo/ Mirror 600x495x3mm	3	
Z	49738	 Roliço oblongo/Percha /Rack 15x27 de metal 976mm	1	
AA	BR=9409 (Branco) JA=9330 (Preto) NO=19695 (Moka)	 Puxador de chapa /Asar/Handle	1	
AB	BR=9408 (Branco) JA=9351 (Preto bri) NO=25677 (Moka bri)	 Puxador aruba /Asar/Handle branco	2	
AC	1178	 Parafuso/ Tornillo/ Screw 3,5x16 BC	4	
AD	56243	 Parafuso flange/ Tornillo/ Screw 3,5x12 ZB	8	
01 Saco médio para acessórios				
01 Saco pequeno para puxadores				



