

# **Manual de montagem**

Instrucciones de montaje Assembly instructions

## **ARM243AMDP**

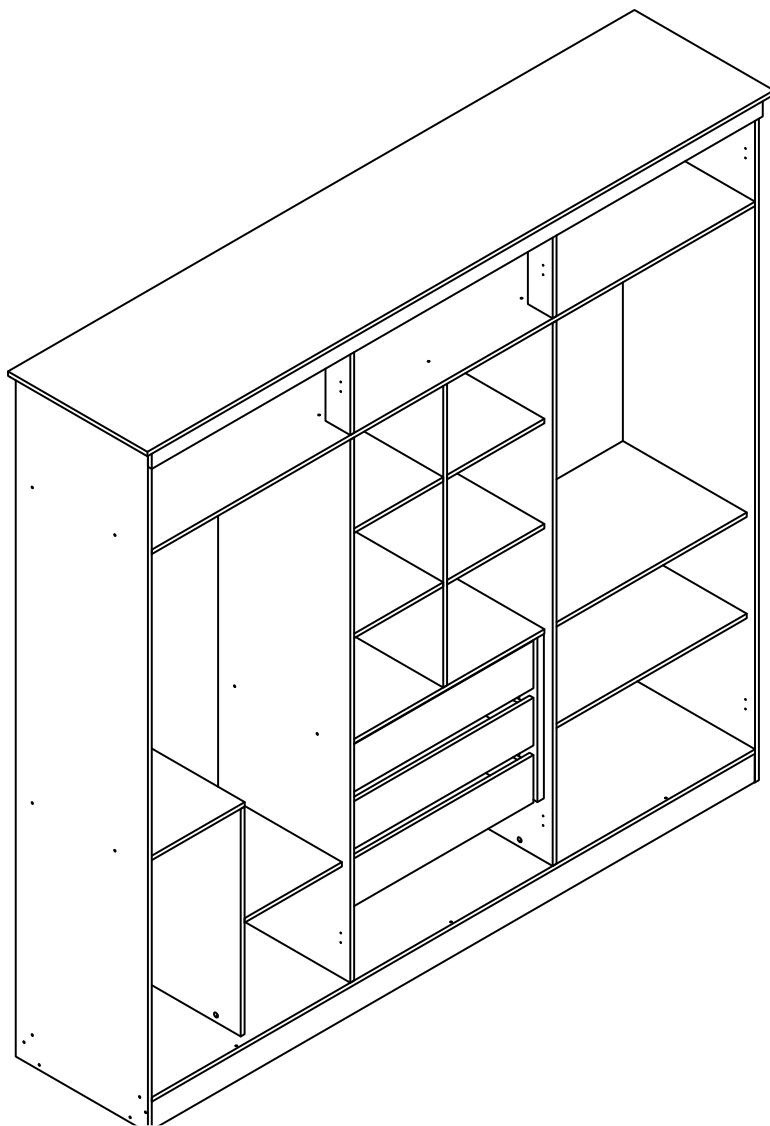

**! Imagens meramente ilustrativas !**  
Imágenes ilustrativas/Images merely illustrative.

Dúvidas? Entre em contato:  
Dudas? Ponerse em contacto:  
Doubts? Get in touch:  
(51) 3635-8839

A montagem deve ser efetuada por 2 pessoas.

El montaje debe ser efectuada por 2 personas.

The assembly must be done by 2 people.

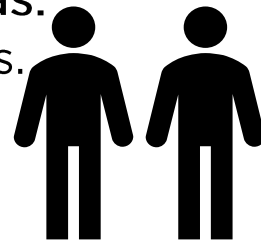

Ferramentas necessárias para montar o móvel.

Herramientas necesarias para armar el mueble.

Tools needed to assemble the furniture.



Dúvidas? Entrar em contato:

Dudas? Ponerse en  
contacto:

Doubts? Get in touch:

Fone: (51) 3635-8839

[www.kappesberg.com.br](http://www.kappesberg.com.br)



Montar o móvel sobre uma superfície limpa e plana.

Armar el mueble sobre una superficie limpia y plana.

Assemble the furniture on a clean, flat surface.

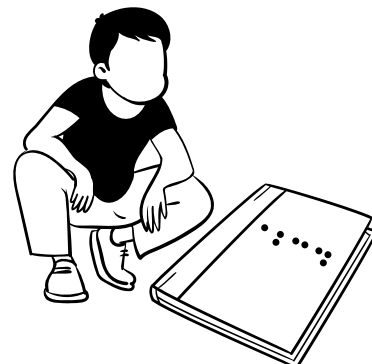

## IDENTIFICAÇÃO DAS PEÇAS / IDENTIFICACIÓN DE LAS PIEZAS PARTS IDENTIFICATION

Quantidade / Cantidad / Amount	Código / Code	Descrição	Descripción	Description	C x L x E	L x W x T
1	P103437	LATERAL DIREITA	LADO DIRECTO	RIGHT SIDE	2300 x 512 x 15 mm	90.55 x 20.16 x 0.59 in
1	P103448	BASE DO MALEIRO	BASE	BASE	2337 x 512 x 15 mm	92.01 x 20.16 x 0.59 in
1	P103493	PRATELEIRA FIXA	ESTANTE	SHELF	392 x 480 x 15 mm	15.43 x 18.90 x 0.59 in
1	P103459	DIVISORIA	DIVISION	DIVISION	764 x 480 x 15 mm	30.08 x 18.90 x 0.59 in
5	P103460	PRATELEIRA SOLTA	PRATELEIRA	PRATELEIRA	377 x 480 x 15 mm	14.84 x 18.90 x 0.59 in
2	P103461	PILASTRA	PILAR	PILLAR	350 x 96 x 15 mm	13.78 x 3.78 x 0.59 in
1	P103466	DIVISORIA	DIVISION	DIVISION	1044 x 480 x 15 mm	41.10 x 18.90 x 0.59 in
2	P102524	RODAPE INTERNO	ZOCALO INTERNO	INTERNAL BASEBOARD	456 x 96 x 15 mm	17.95 x 3.78 x 0.59 in
1	P103491	PRATELEIRA FIXA	ESTANTE	SHELF	769 x 480 x 15 mm	30.28 x 18.90 x 0.59 in
1	P103438	BASE	BASE	BASE	2337 x 512 x 15 mm	92.01 x 20.16 x 0.59 in
1	P103457	TAMPO DE GAVETA	TAPA DEL CAJON	TOP OF DRAWERS	769 x 480 x 15 mm	30.28 x 18.90 x 0.59 in
1	P103435	CHAPÉU	SOMBRERO	HAT	2427 x 540 x 15 mm	95.55 x 21.26 x 0.59 in
1	P103436	LATERAL ESQUERDA	LADO IZQUERDA	LEFT SIDE	2300 x 512 x 15 mm	90.55 x 20.16 x 0.59 in
2	P102301	RODAPE	ZOCALO	BASEBOARD	2337 x 96 x 15 mm	92.01 x 3.78 x 0.59 in
6	P103465	COSTA	COSTA	COAST	1841 x 390 x 3 mm	72.48 x 15.35 x 0.12 in
6	P102202	LATERAL DE GAVETA	LADO DEL CAJÓN	DRAWER SIDE	400 x 120 x 15 mm	15.75 x 4.72 x 0.59 in
3	P102254	FUNDO DE GAVETA	FONDO DEL CAJÓN	DRAWER BOTTOM	678 x 398 x 3 mm	26.69 x 15.67 x 0.12 in
3	P102253	CABECEIRA DE GAVETA	CABEZAL DEL CAJÓN	DRAWER HEAD	665 x 120 x 15 mm	26.18 x 4.72 x 0.59 in
3	P102256	FRENTE DE GAVETA	FRENTE DEL CAJÓN	DRAWER FRONT	700 x 160 x 15 mm	27.56 x 6.30 x 0.59 in
4	P103463	AFASTADOR	RETRACTOR	SEPARADOR	554 x 70 x 25 mm	21.81 x 2.76 x 0.98 in
1	P103450	DIVISORIA ESQUERDA	PARTICIÓN IZQUIERDA	LEFT PARTITION	1823 x 512 x 15 mm	71.77 x 20.16 x 0.59 in
1	P103451	DIVISORIA DIREITA	PARTICIÓN DERECHA	RIGHT PARTITION	1823 x 512 x 15 mm	71.77 x 20.16 x 0.59 in
1	P103456	PRATELEIRA SOLTA	ESTANTE	SHELF	769 x 480 x 15 mm	30.28 x 18.90 x 0.59 in
1	P103497	RODAFORRO	MARCO SUPERIOR	UPPER FRAME	2367 x 64 x 15 mm	93.19 x 2.52 x 0.59 in
1	P103569	COSTA	COSTA	COAST	2357 x 365 x 3 mm	92.80 x 14.37 x 0.12 in

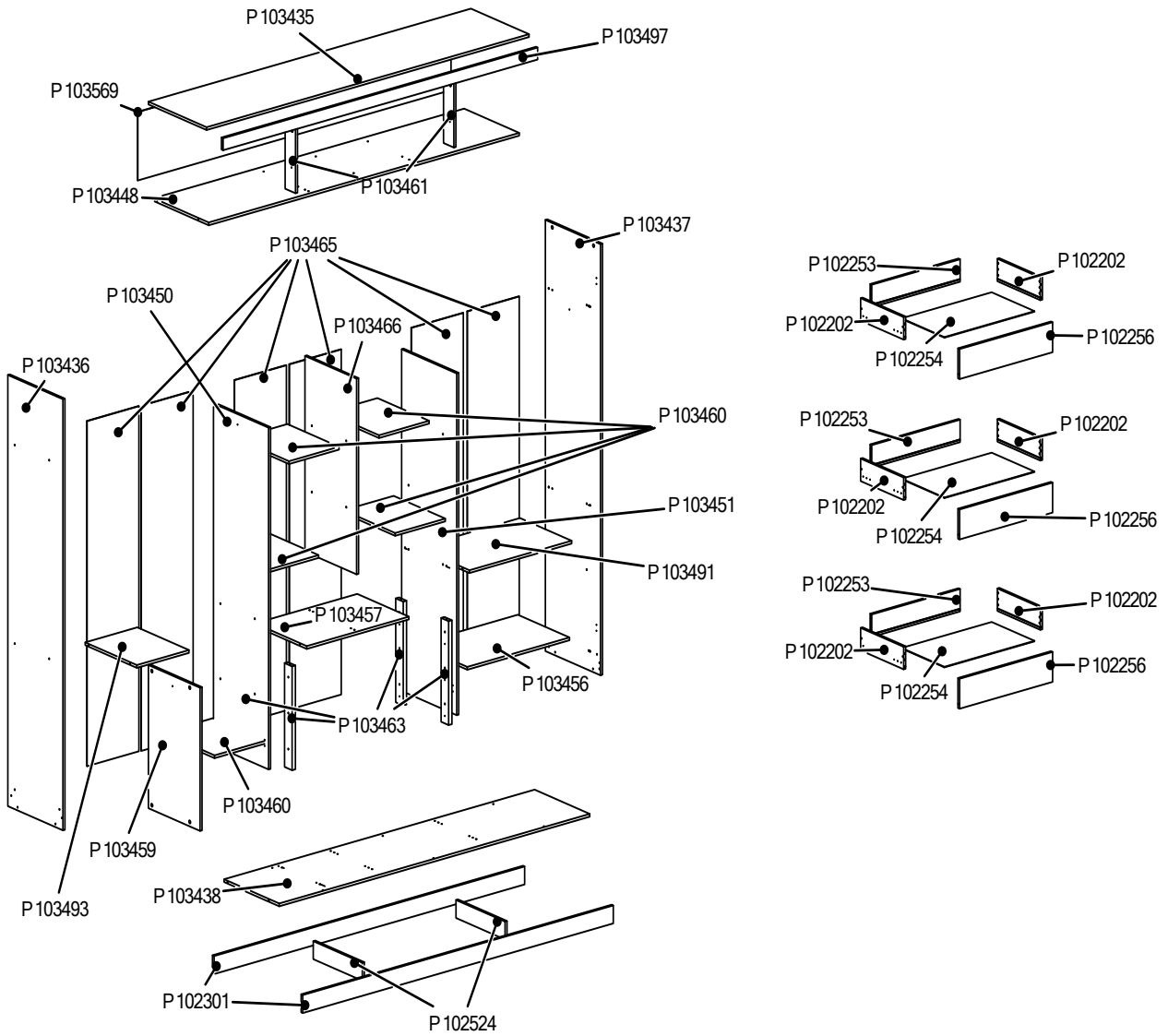

## IDENTIFICAÇÃO DOS ACESSÓRIOS / IDENTIFICACIÓN DE ACCESORIOS IDENTIFICATION OF ACCESSORIES

**NOTAS: A separação dos acessórios antes de iniciar a montagem facilitará a mesma. Em caso de dúvida na identificação, coloque o acessório sobre a régua.**

Nota: Separar los accesorios antes de iniciar el montaje facilitará el mismo. En caso de duda en la identificación, coloque el accesorio en la regla.





NOTE: Separating the accessories before starting assembly will make it easier. In case of doubt in the identification, place the accessory on the ruler.

	Quantidade / Cantidad / Amount	Código / Code	Descrição	Descripción	Description
	141	107	PREGO 10 X 10 (0,308G) LISO	CLAVO 10 X 10	NAIL 10 X 10
	54	1423	FIXADOR DE COSTA	FIJADOR DE ESPALDA	BACK FIXER
	50	226	P.CHATO 4,0 X 40MM	TORNILLO 4,0 X 40MM	SCREW 4,0 X 40MM
	6	41921	SUP. P/ CABIDEIRO OBLONGO METAL COR ALU. ESCURO	SOPORTE PERCHA	CLOTHES RACK
	108	4214	P.CHATO 3,5 X 14 CAB. PHILLIPS REBAIXADA ZB	TORNILLO 3,5 X 14MM	SCREW 3,5 X 14MM
	62	1802	CAVILHAS DE MADEIRA 6X30 PINUS	TARUGO 6X30MM	DOWEL 6X30MM
	14	30950	TAMBOR P/ MINIFIX 15MM ZAMAQ 09.11.007	CILINDRO 15MM	BARREL 15MM
	14	30945	PARAFUSO DE ACO P/ MINIFIX	TORNILLO DE ACERO PARA MINIFIX	STEEL SCREW FOR MINIFIX

## IDENTIFICAÇÃO DOS ACESSÓRIOS / IDENTIFICACIÓN DE ACCESORIOS IDENTIFICATION OF ACCESSORIES

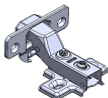
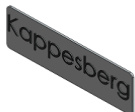
	28	TAPA FURO 13MM	TAPA FURO 13MM	TAPA DEL AGUJERO 13MM	SCREW CAP COVER 13MM
	24	000118	SUP. P/ PRAT. 6 X 8MM BEGE (COR 004)	SOPORTE DE ESTANTE 6 X 8	SHELF SUPPORT 6 X 8
	8	001925	CAVILHA 6 X 50MM MADEIRA	TARUGO 6 X 50MM	DOWEL 6 X 50MM
	14	19MM	TAPA FURO 19MM	TAPA DEL AGUJERO 19MM	SCREW CAP COVER 19MM
	2	035940	ROLICO OBLONGO 15X19,5 ALUMINIO NATURAL FRISADO 762MM (RX-C13)	ROLICO OBLONGO 15X19,5 ALUMINIO NATURAL FRISADO 762MM (RX-C13)	ROLICO OBLONGO 15X19,5 ALUMINIO NATURAL FRISADO 762MM (RX-C13)
	1	035910	ROLICO OBLONGO 15X19,5 ALUMINIO NATURAL FRISADO 368MM (RX-C13)	SOPORTE PERCHERO 368MM	CLOTHES BRACKET 368MM
	15	000899	CANTONEIRA PLASTICA PRETA	CANTONERA	PLASTIC HANDLE
	8	001901	SAPATA DESLIZADORA PRETA 15 X 6 (02.02.026)	ZAPATO 15 X 6	SHOE 15 X 6
	8	000108	PREGO 12 X 12 (0,6127G) ARDOX	CLAVO 12 X 12	NAIL 12 X 12

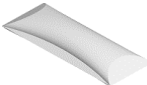
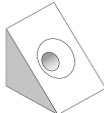
## IDENTIFICAÇÃO DOS ACESSÓRIOS / IDENTIFICACIÓN DE ACCESORIOS IDENTIFICATION OF ACCESSORIES

	72	61971	P.PANELA 4,0 X 14 ZB P/DOBRADICA	TORNILLO 4,0 X 14	SCREW 4,0 X 14
	18	78394	DOBRAD. CURVA 35MM C/ CALCO H-2 NIQUELADA	BISAGRA Y FIJADOR	HINGE AND SHIM
	1	75900	ETIQUETA MARCA KAPPESBERG 40 X 12 HIGH TAG PRATA FOSCO	ETIQUETA KAPPESBERG	ETIQUETTE KAPPESBERG
	3	38305	CORREDICA TELESCOPICO MINI LIGHT (H32/30) 400MM	CORREDERA METÁLICA 400MM	METAL SLIDE 400MM
	12	414	P.PANELA 4,0 X 35 CAB. PHILLIPS ZB/BC	TORNILLO 4,0 X 35	SCREW 4,0 X 35
	1	41	COLA BRANCA EM BISNAGA (10GR)	COLA BRANCA EM BISNAGA (10GR)	COLA BRANCA EM BISNAGA (10GR)
	6	18458	SUPORE TRIANGULAR PRETO	SOPORTE TRIANGULO NEGRO	BLACK TRIANGLE SUPPORT
	6	5256	PARAFUSO CHATO 4,0 X 20 BC	TORNILLO PLANO 4,0 X 20 BC	FLAT SCREW 4,0 X 20 BC
	3	PH	PERF. H26 1825MM CARVALLE	PERFIL H 1825MM	PROFILE H 1825MM

## INSTALAÇÃO MINIFIX

Identificar seta no corpo do tambor de minifix. A seta DEVE apontar para o buraco na borda do painel. Empurrar o tambor até o buraco.

## INSTALACIÓN DE LA LEVA

Identifique la flecha en los muertos de la leva. La flecha debe apuntar hacia el agujero en el borde del panel. Empuje la leva hasta el fondo del orificio.

## INSTALLING CAM

Identify arrow on head of cam. Arrow MUST point toward hole in edge of panel. Push cam all the way down into hole.

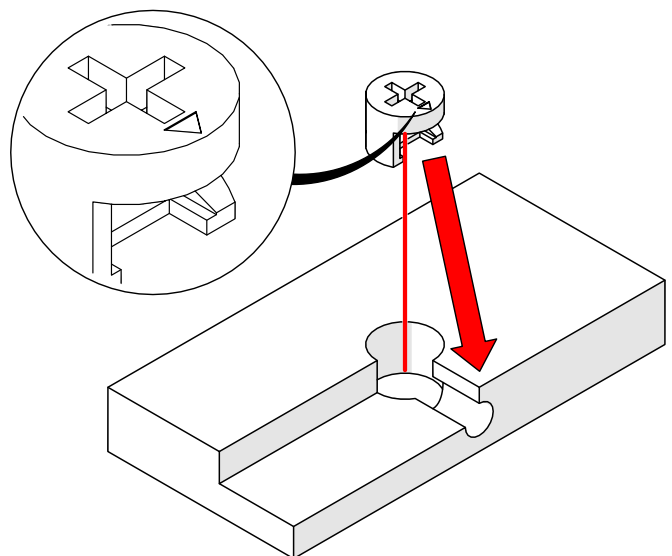

## ALINHAMENTO DO TAMBOR E PARAFUSO

A seta do tambor de minifix deve ser apontada para o buraco e inserir o parafuso do minifix do tambor contido no buraco. Certifique-se de que as peças se unam.

## ALINEACIÓN DE LA LEVA Y EL PASADOR

Asegúrese de que la flecha de la leva apunte hacia el orificio e inserte la clavija de la leva en el orificio. Asegúrese de que las piezas se unen.

## CAM AND DOWEL ALIGNMENT

Ensure the arrow on the cam points toward hole and insert cam dowel into hole. Make sure pieces join together.

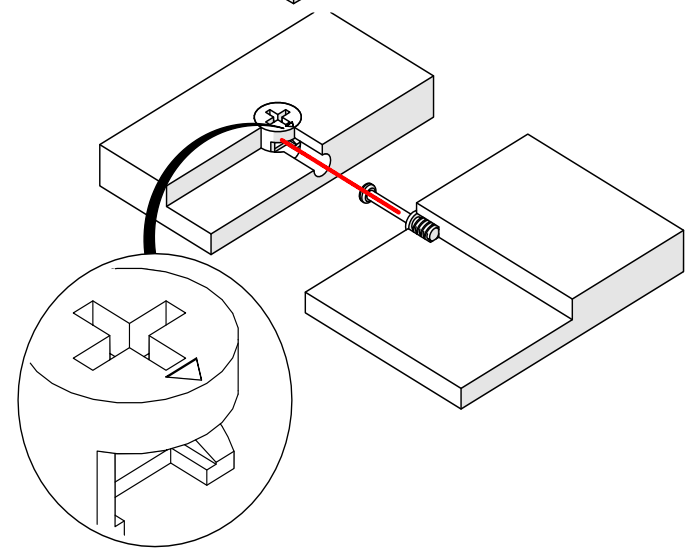

## CÂMARA DE COMPENSAÇÃO DE TENSÃO

Use uma chave de fenda para girar a came. Girar o tambor minifix (no sentido horário) até que esteja totalmente apertado. Ligeiramente mais de meia volta.

## APRIETE DE LA LEVA

Utilice un destornillador para girar la leva. Gire la leva (en el sentido de las agujas del reloj) hasta que esté completamente apretada. Un poco más de media vuelta.

## TIGHTENING CAM

Use screwdriver to turn cam. Turn cam (clockwise) until fully tightened. Slightly more than half a turn.

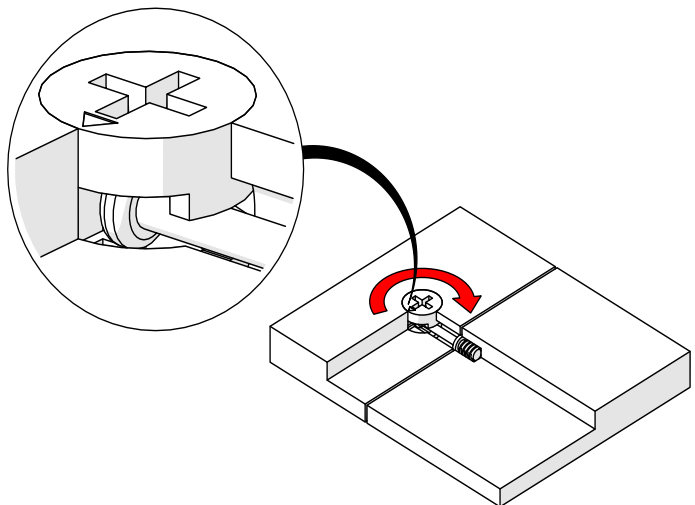



## PASSO / PASO / STEP 1

Cód.	Qtde.
001802	4

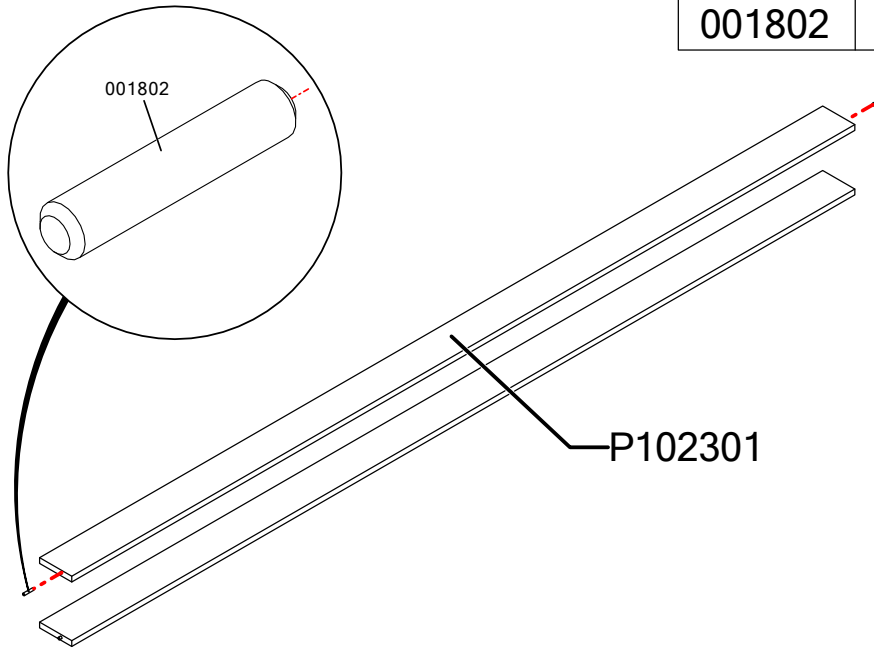

## PASSO / PASO / STEP 2

Cód.	Qtde.
001925	4

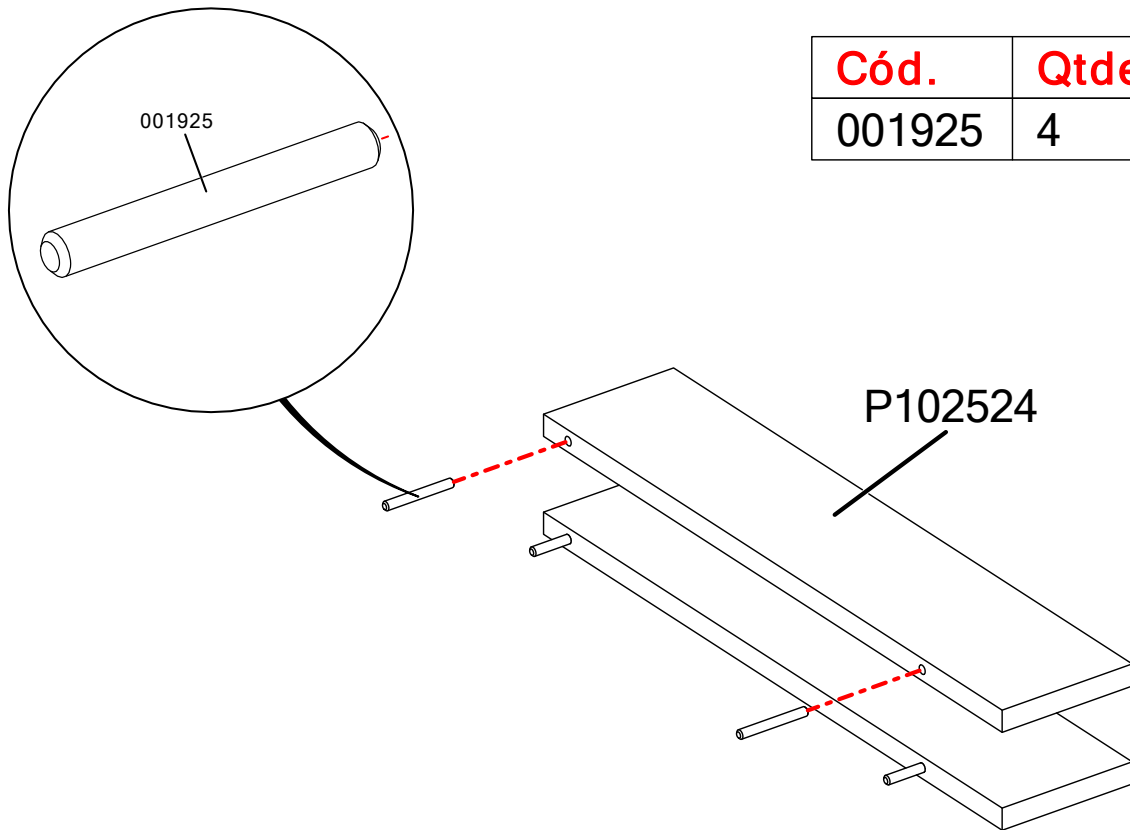

## PASSO / PASO / STEP 3

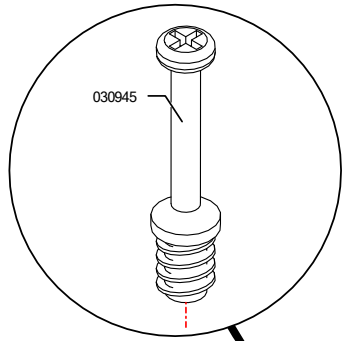

Cód.	Qtde.
030945	6

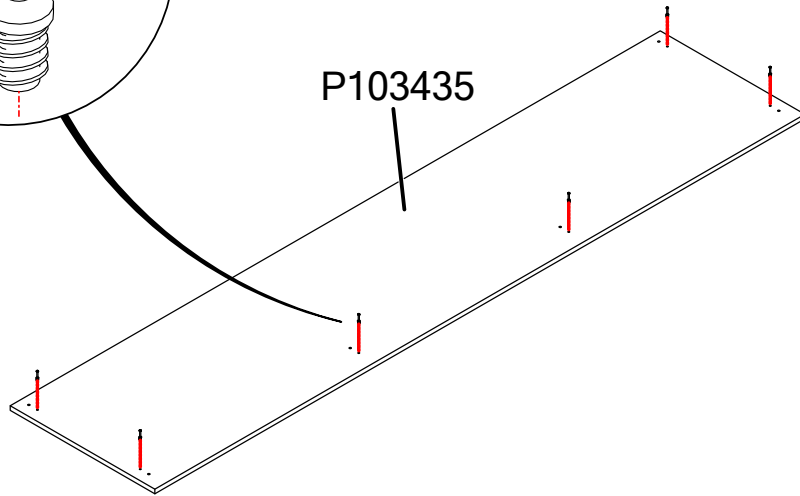

## PASSO / PASO / STEP 4

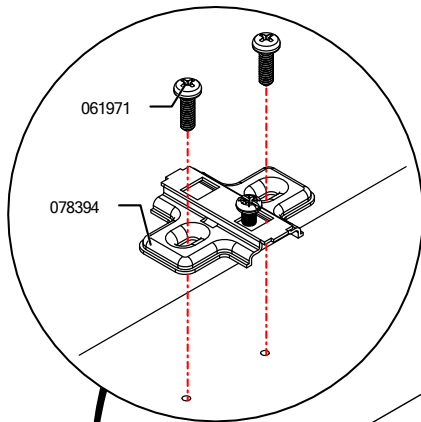

Cód.	Qtde.
078394	2
061971	4
041921	2
004214	4
001802	2

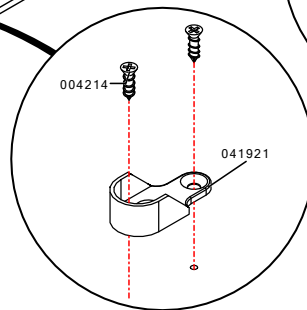
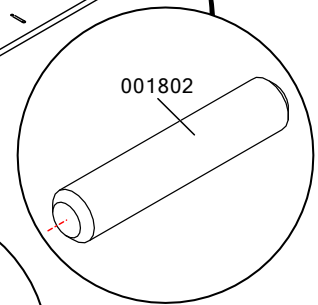
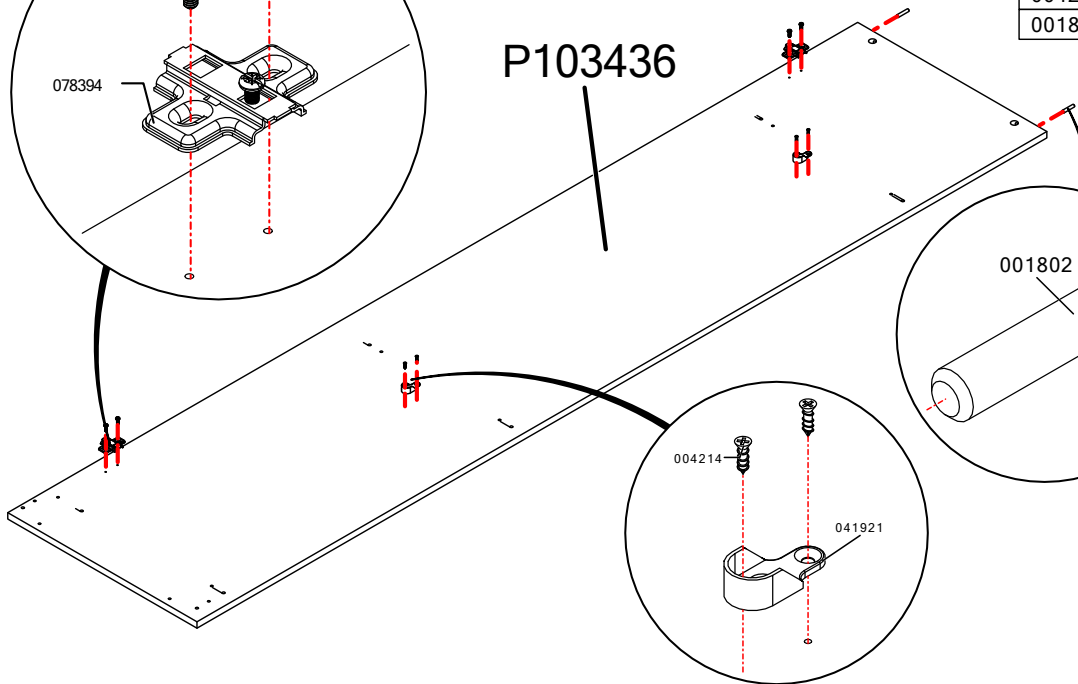

## PASSO / PASO / STEP 5

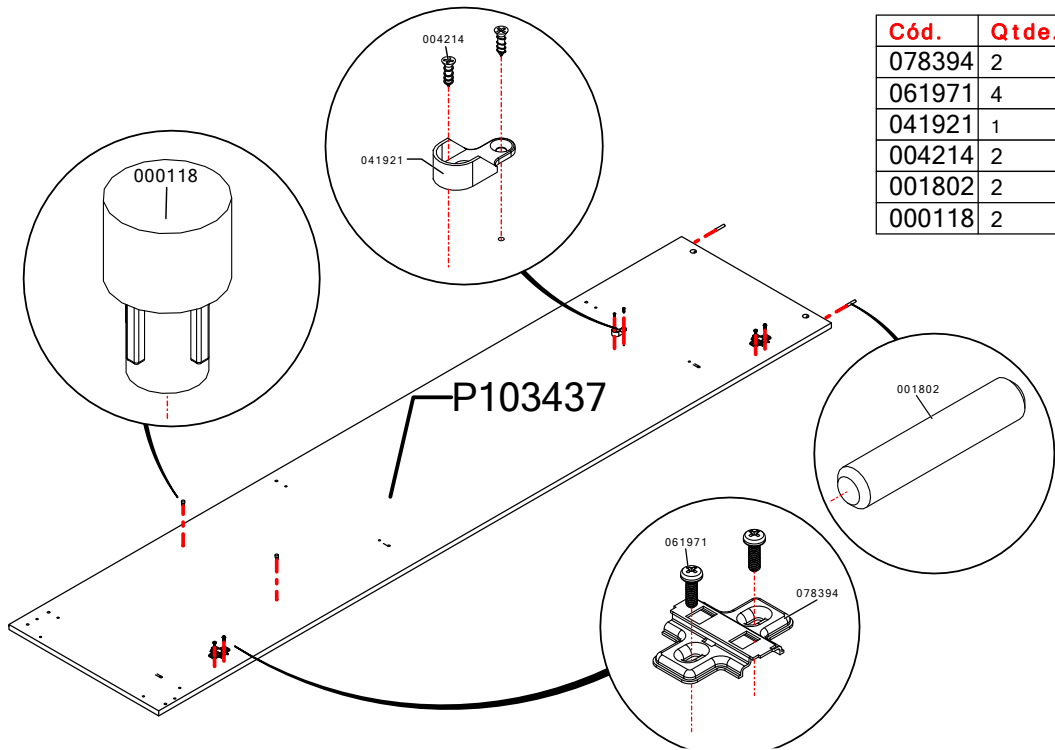

## PASSO / PASO / STEP 6

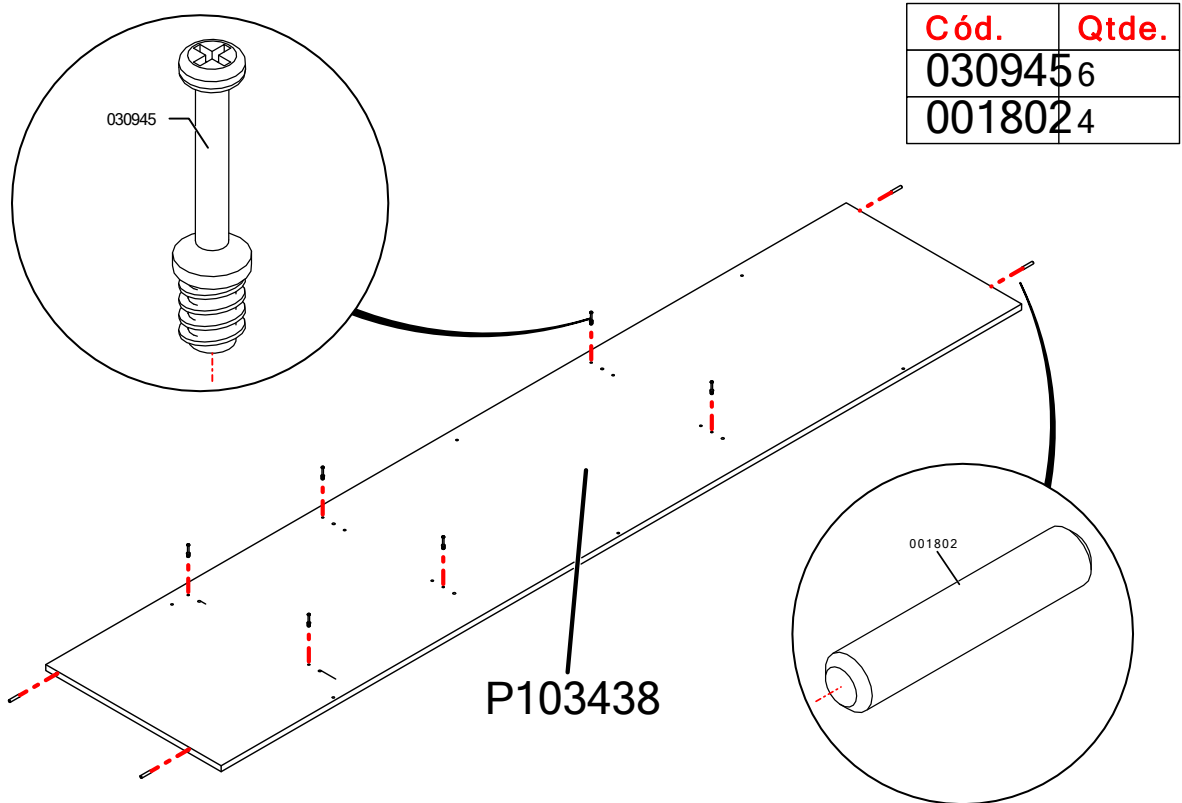

## PASSO / PASO / STEP 7

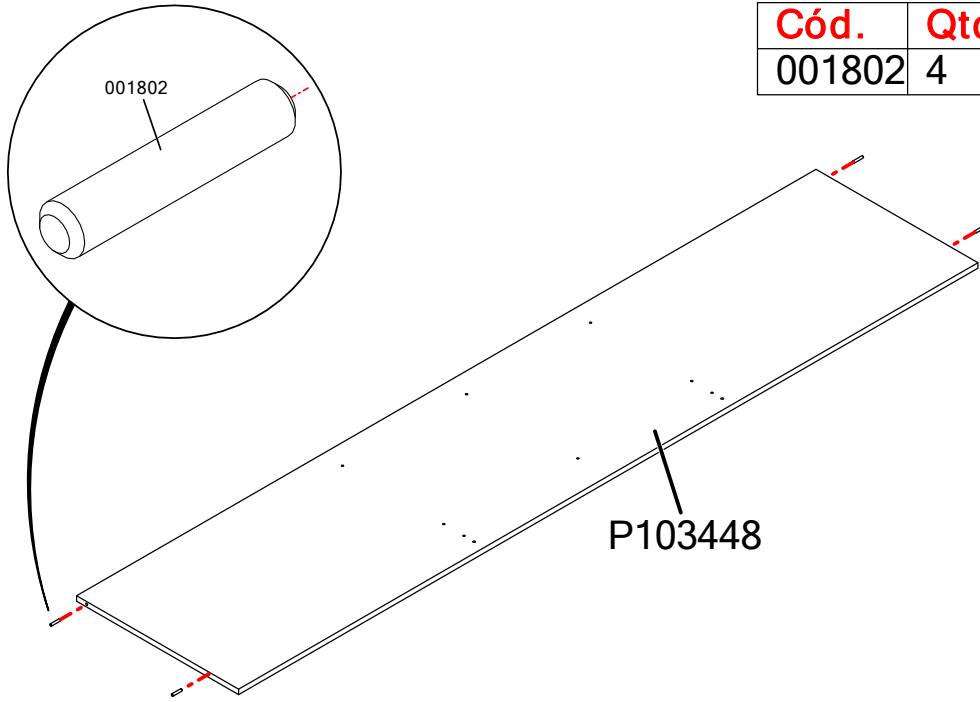

Cód.	Qtde.
001802	4

## PASSO / PASO / STEP 8

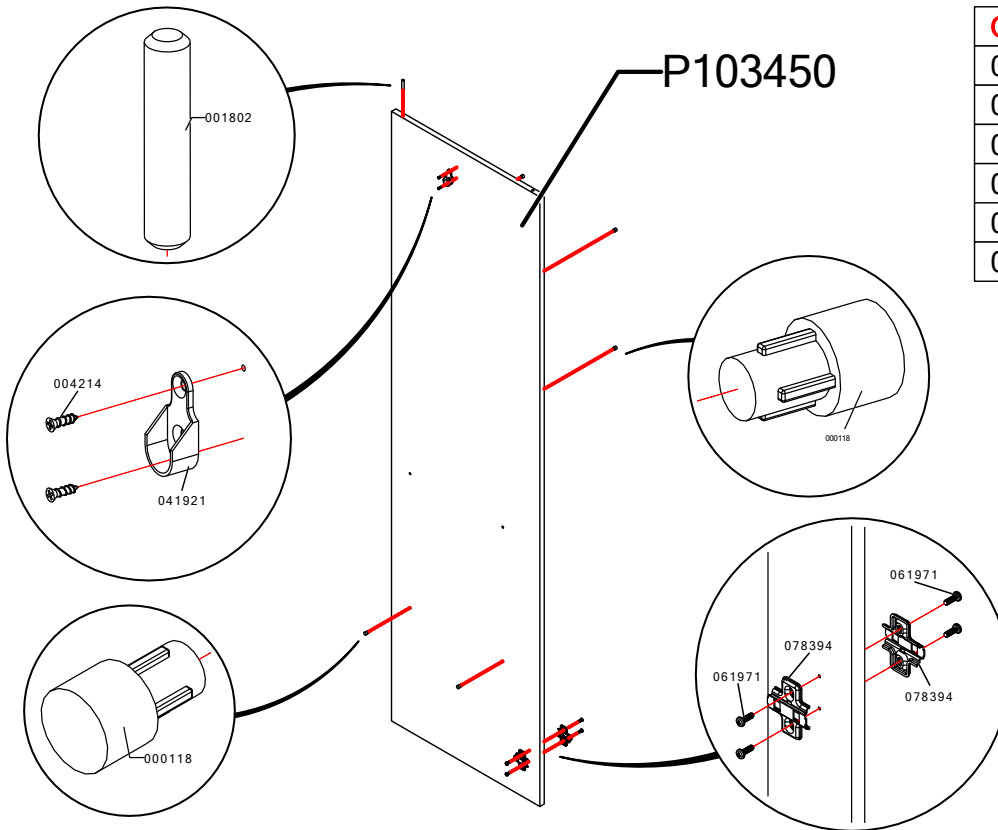

Cód.	Qtde.
078394	2
061971	4
041921	1
004214	2
001802	1
000118	6

## PASSO / PASO / STEP 9

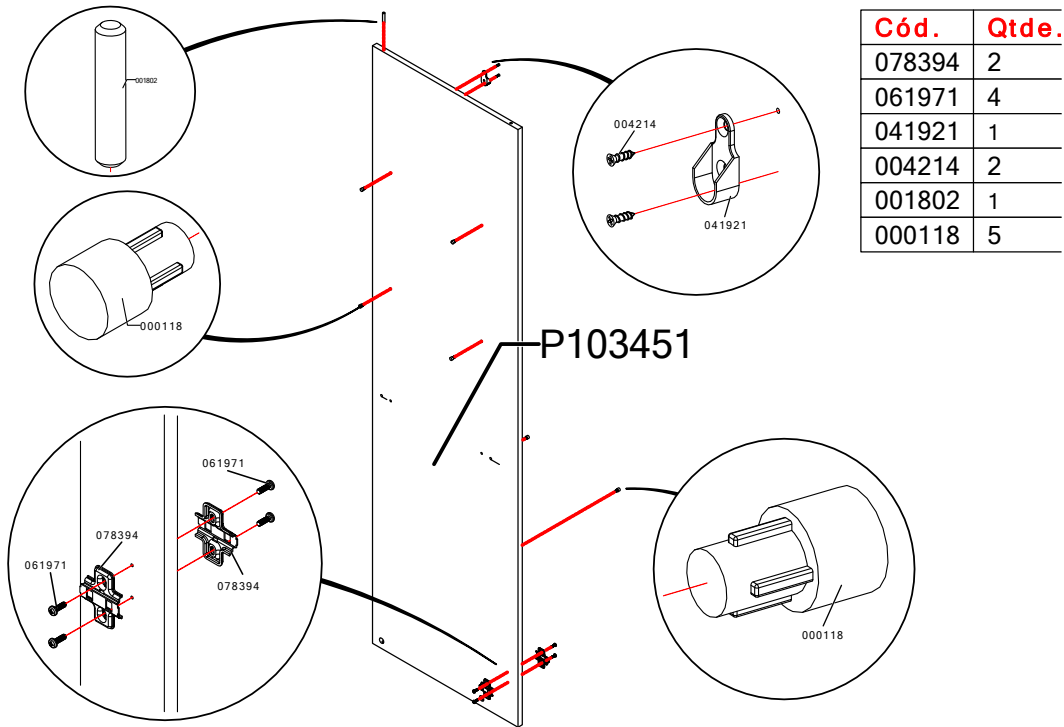

## PASSO / PASO / STEP 10

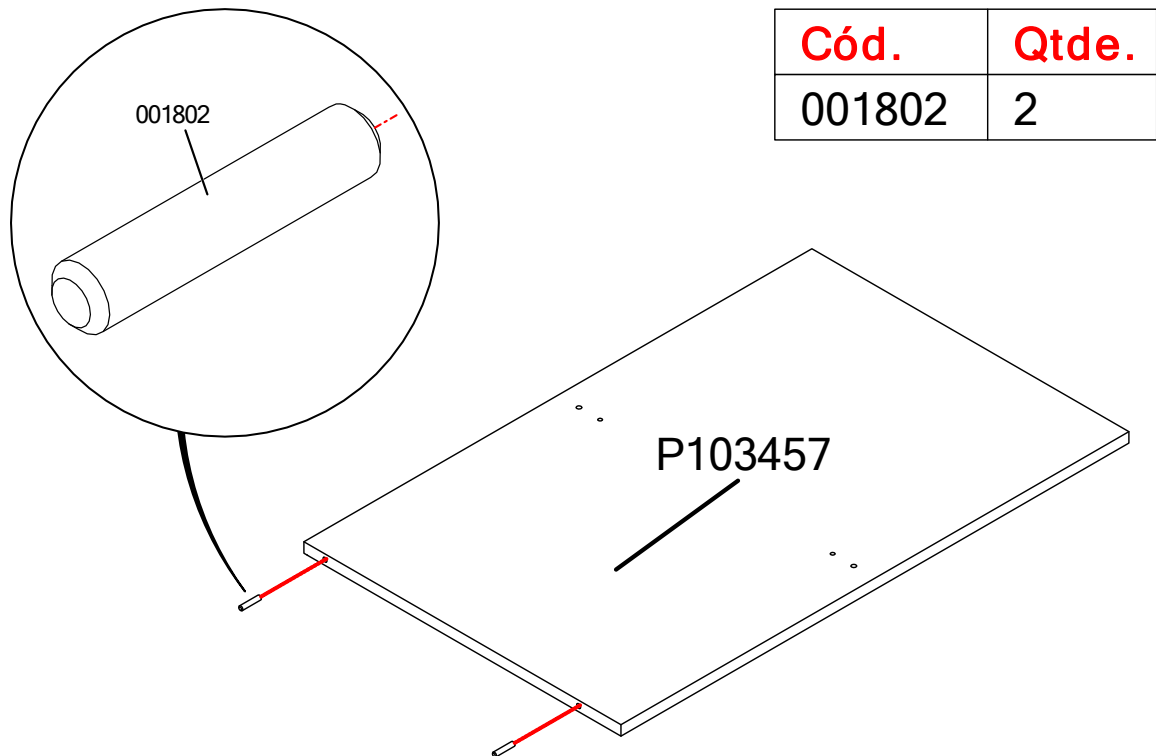

## PASSO / PASO / STEP 11

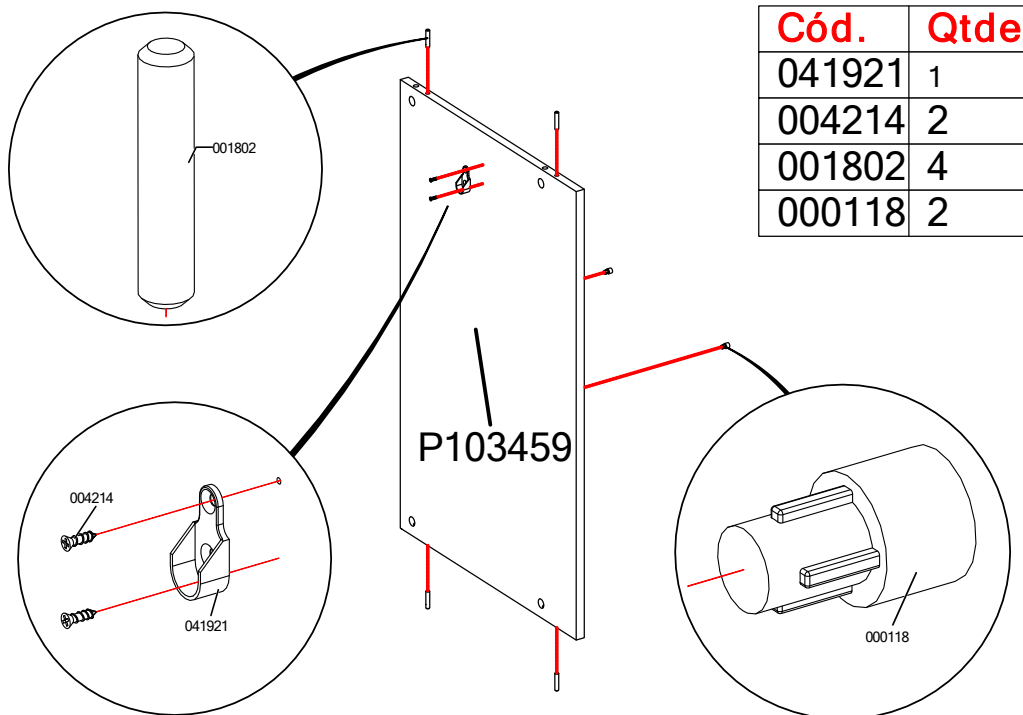

Cód.	Qtde.
041921	1
004214	2
001802	4
000118	2

## PASSO / PASO / STEP 12

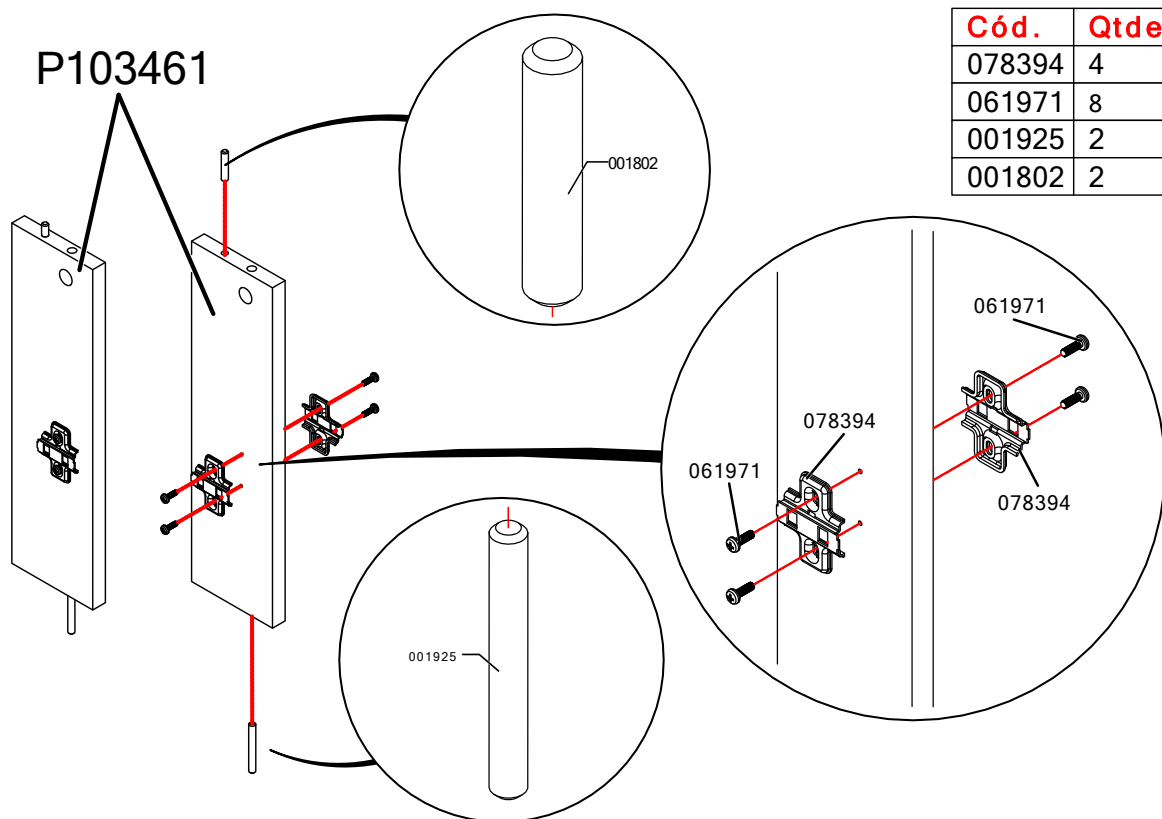

Cód.	Qtde.
078394	4
061971	8
001925	2
001802	2

## PASSO / PASO / STEP 13

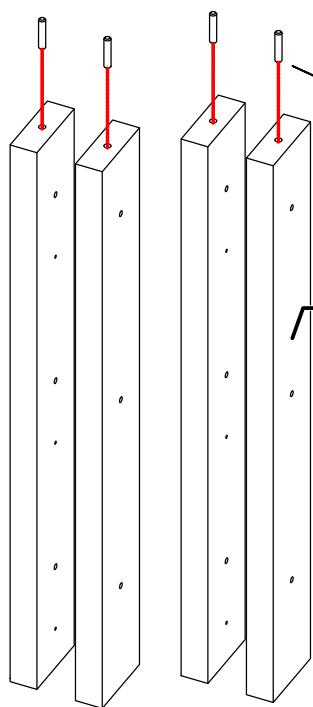

P103463

Cód.	Qtde.
001802	4

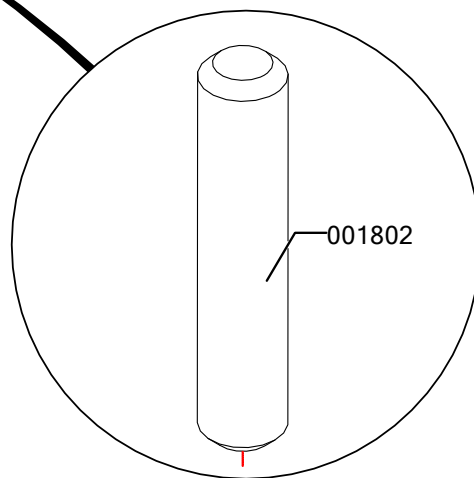

001802

## PASSO / PASO / STEP 14

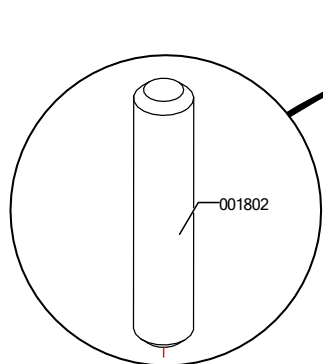

001802

Cód.	Qtde.
001802	4
000118	8

P103466

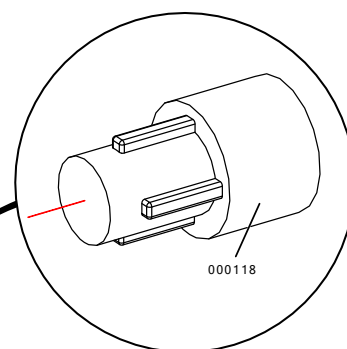
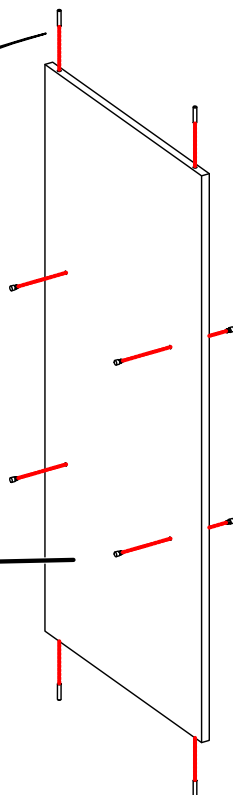

000118

## PASSO / PASO / STEP 15

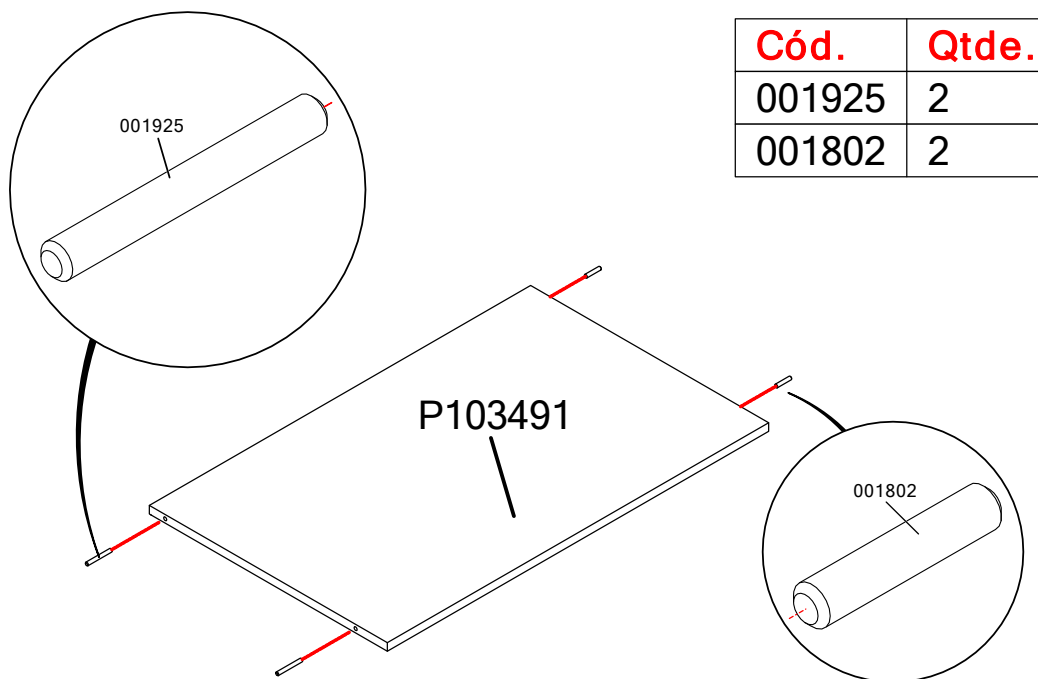

Cód.	Qtde.
001925	2
001802	2

## PASSO / PASO / STEP 16

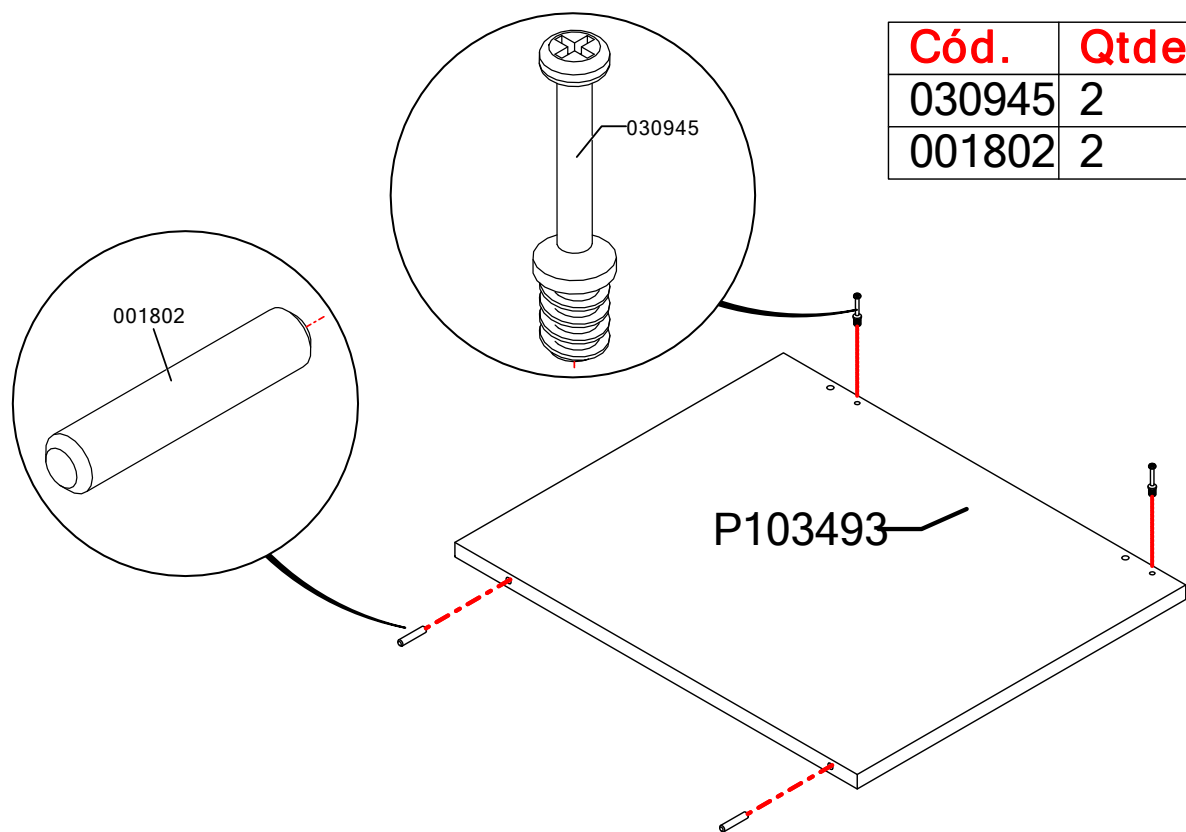

Cód.	Qtde.
030945	2
001802	2



## PASSO / PASO / STEP 17

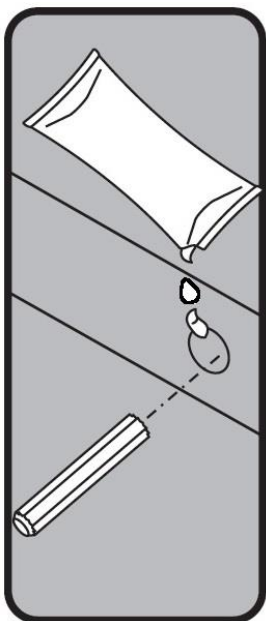

Cód.	Qtde.
001802	12

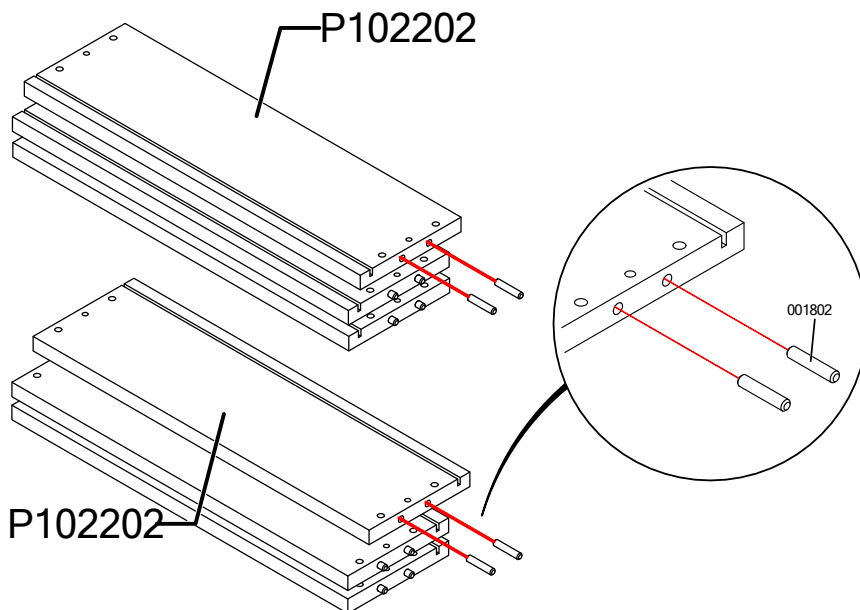

## PASSO / PASO / STEP 18

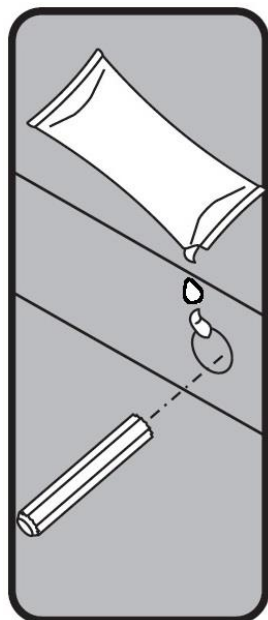

Cód.	Qtde.
001802	12

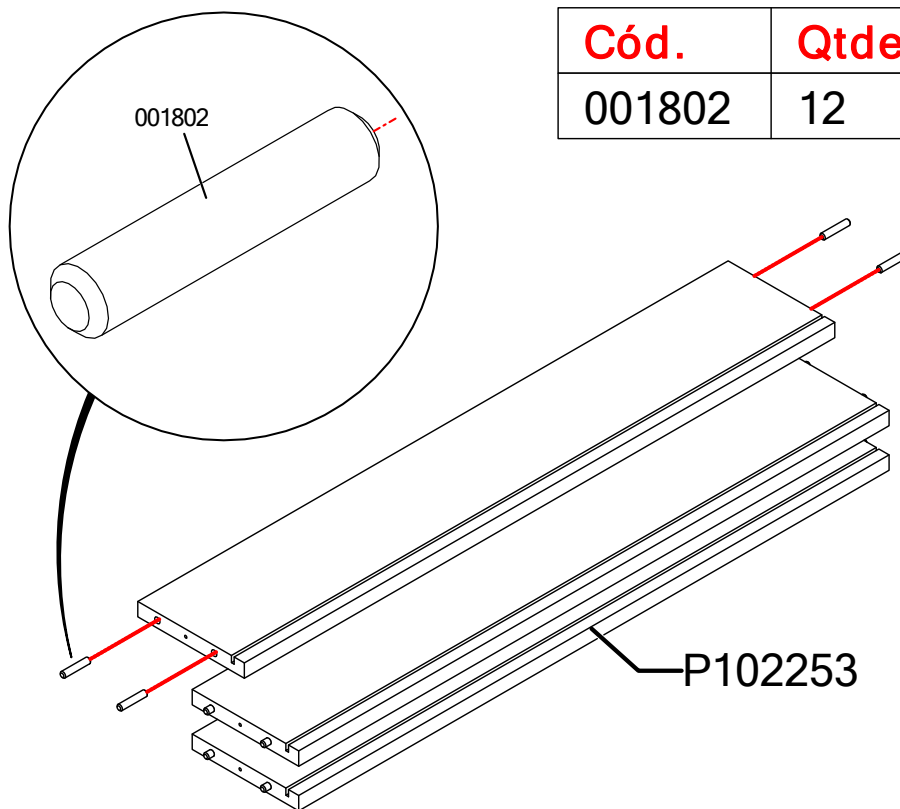

## PASSO / PASO / STEP 19

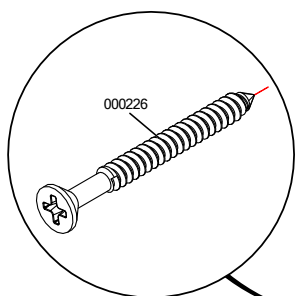

Cód.	Qtde.
000226	6

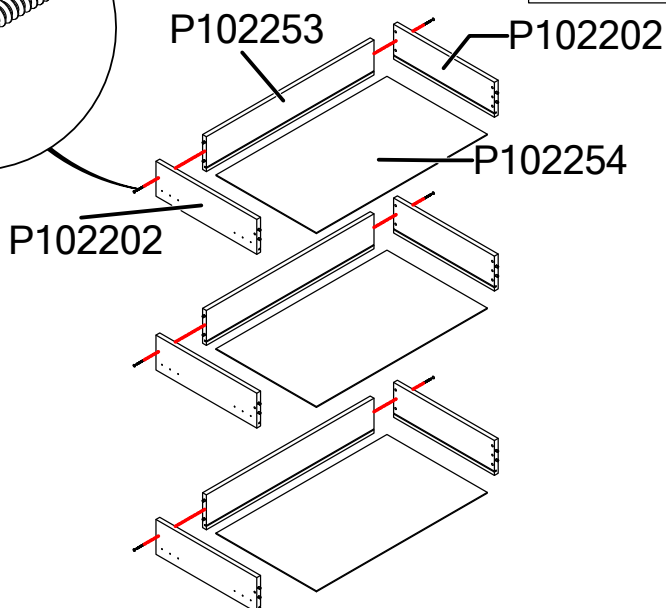

## PASSO / PASO / STEP 20

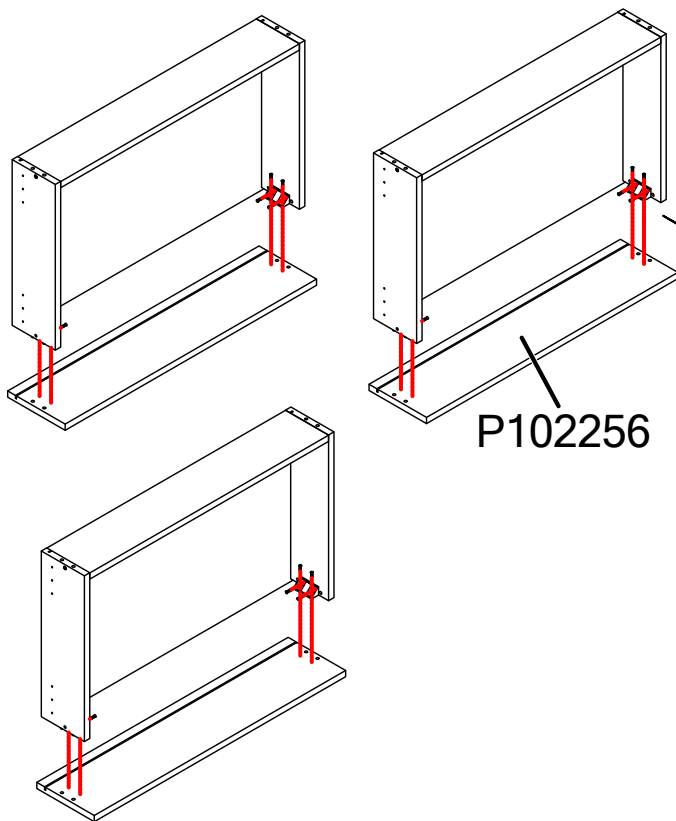

Cód.	Qtde.
004214	24
000899	6

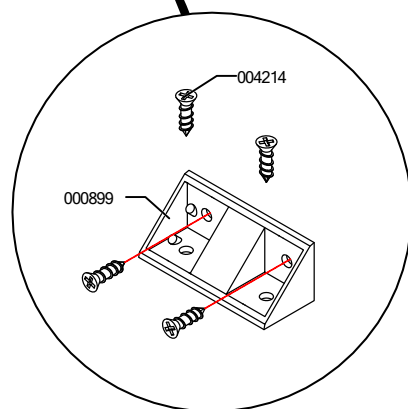

## PASSO / PASO / STEP 21

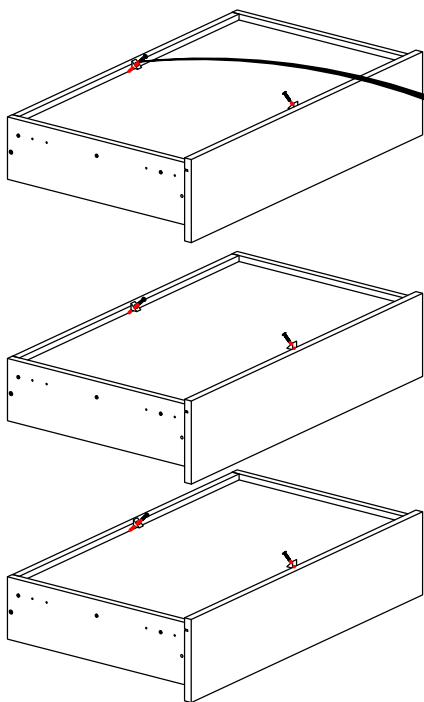

Cód.	Qtde.
018458	6
005256	6

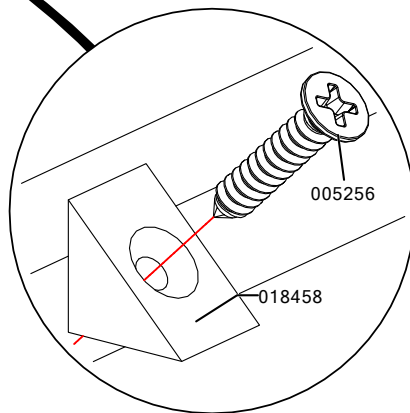

## PASSO / PASO / STEP 22

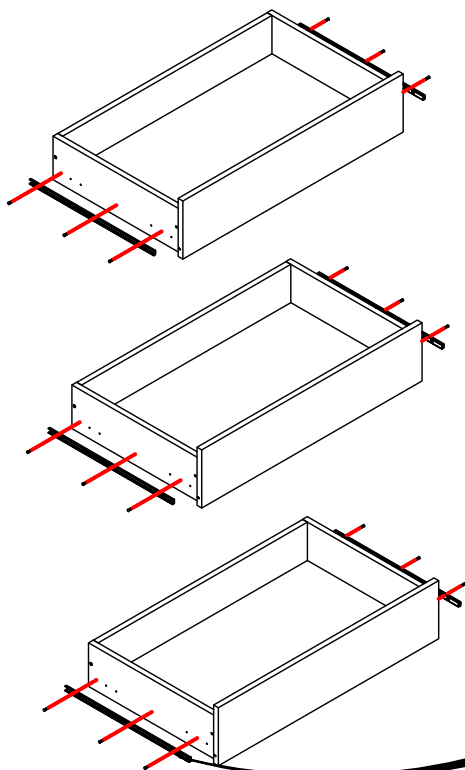

Cód.	Qtde.
038305	6
004214	18

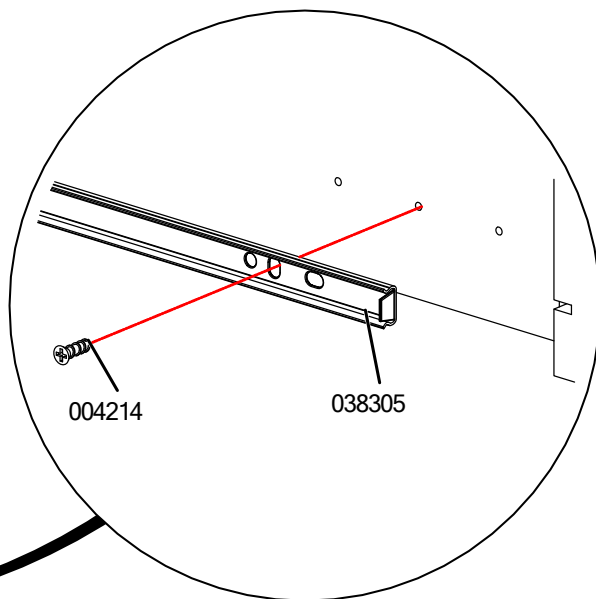

## PASSO / PASO / STEP 23

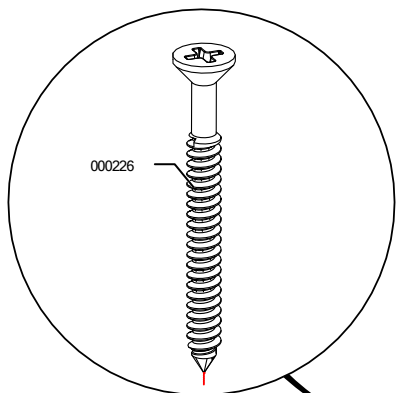

Cód.	Qtde.
000226	4

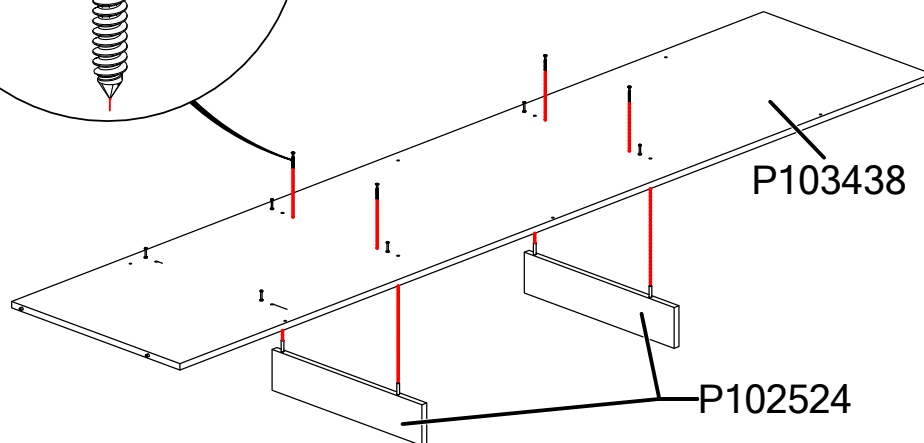

## PASSO / PASO / STEP 24

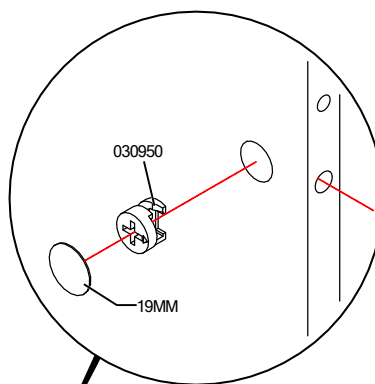

Cód.	Qtde.
030950	6
19MM	6

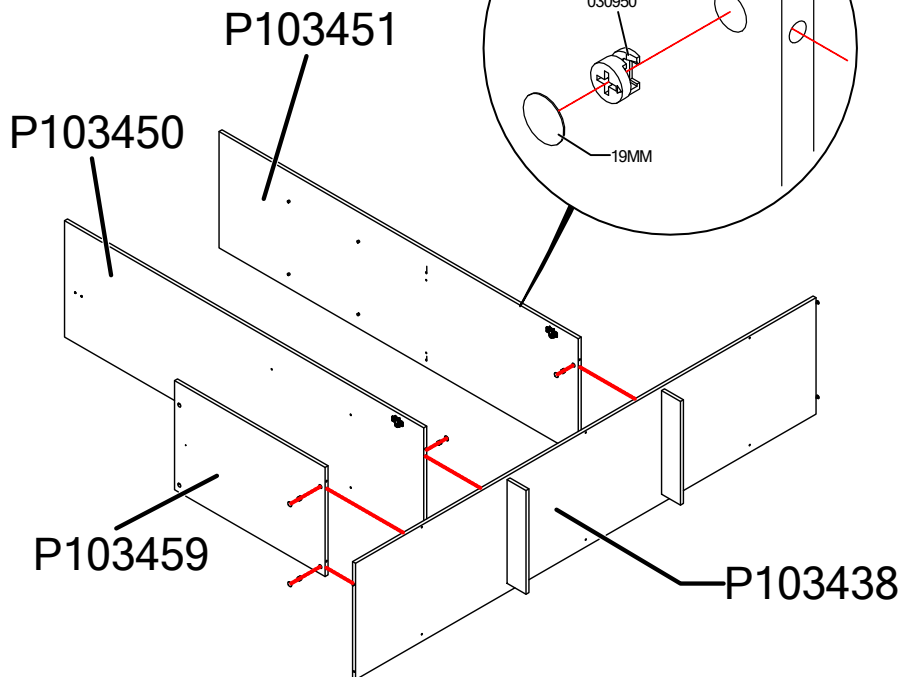

## PASSO / PASO / STEP 25

Cód.	Qtde.
000226	2

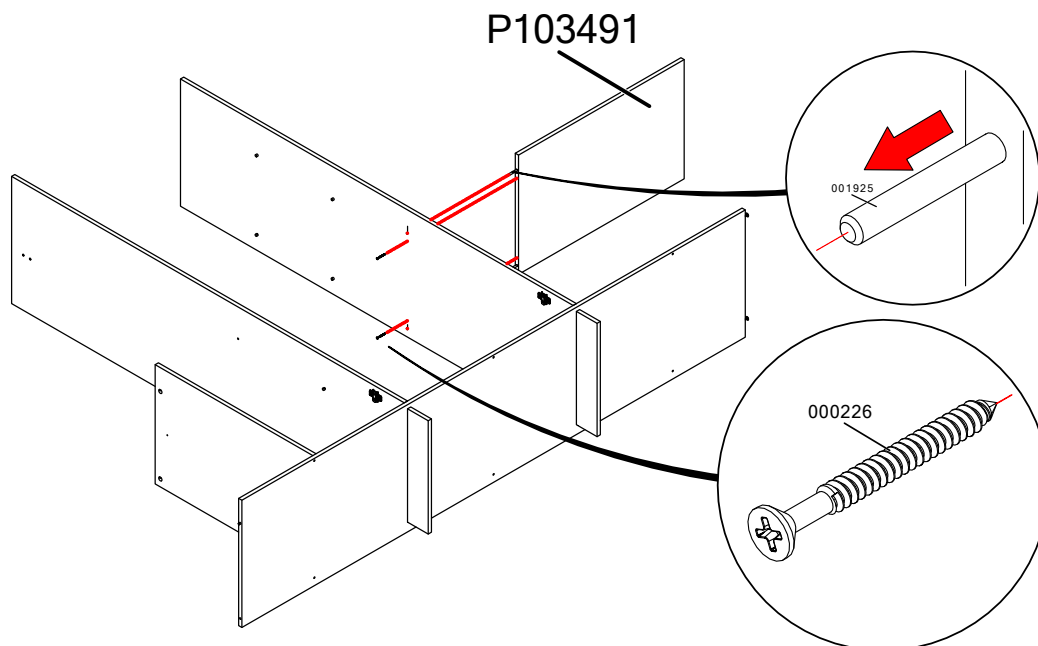

## PASSO / PASO / STEP 26

Cód.	Qtde.
030950	2
000226	2
19MM	2
13MM	2

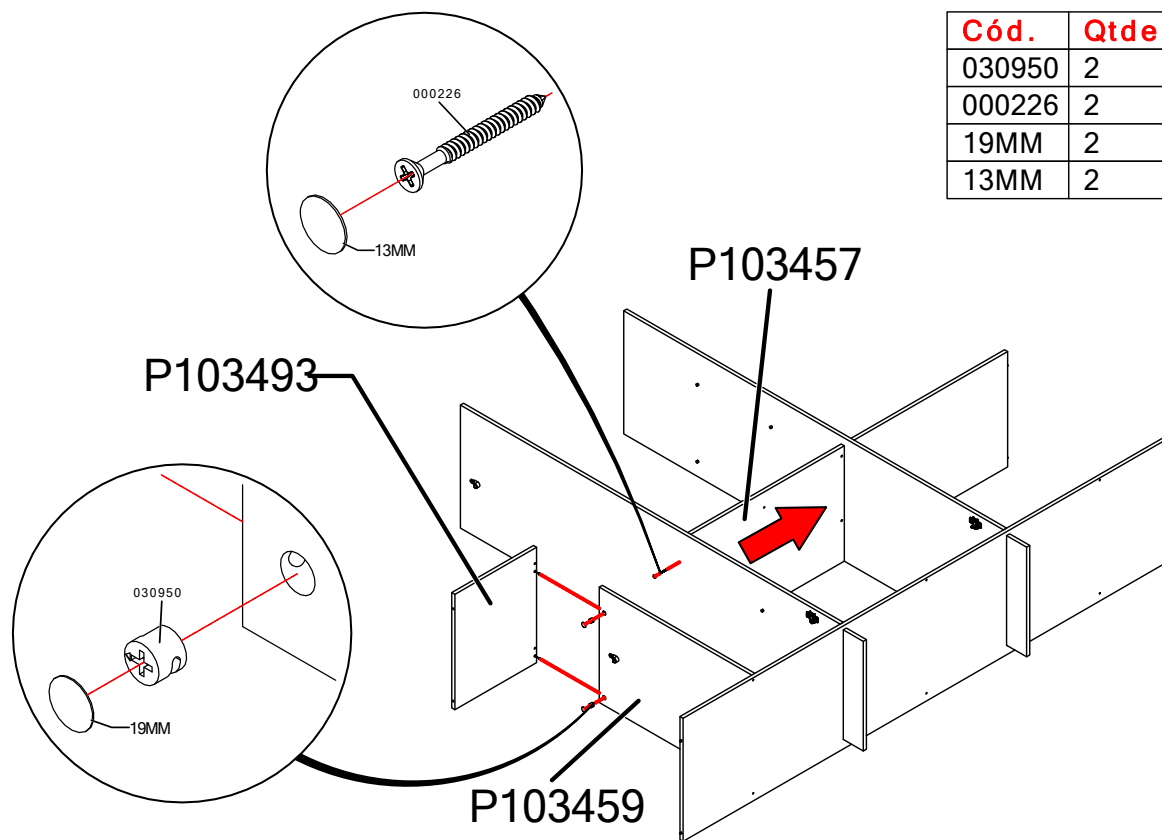

## PASSO / PASO / STEP 27

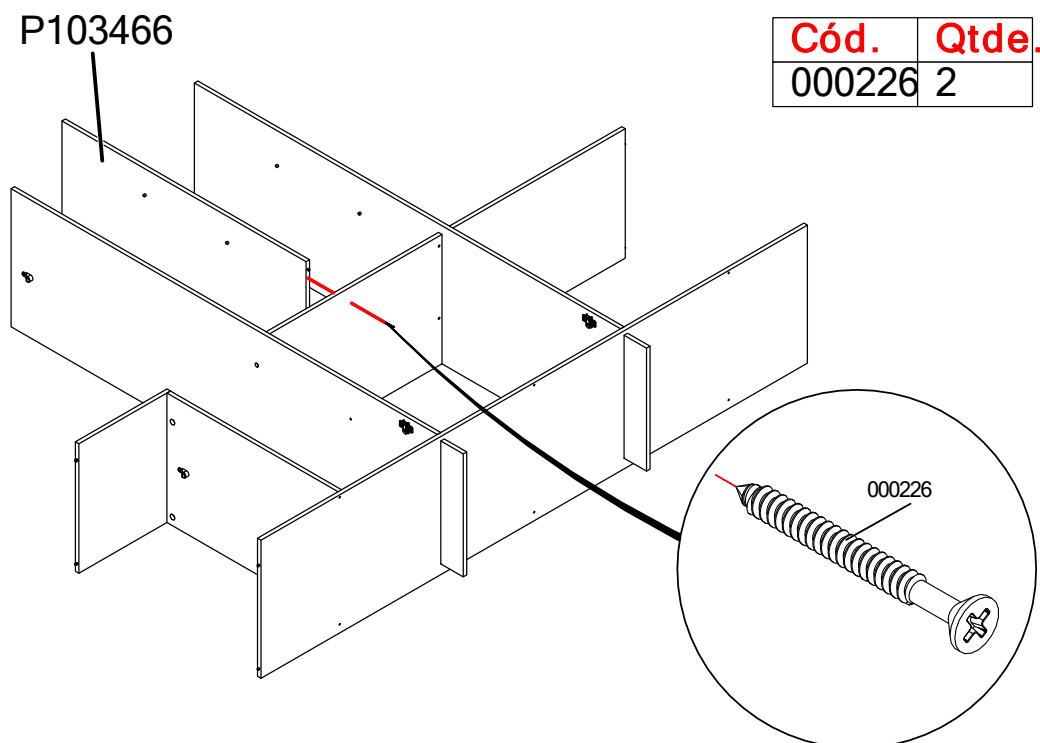

## PASSO / PASO / STEP 28

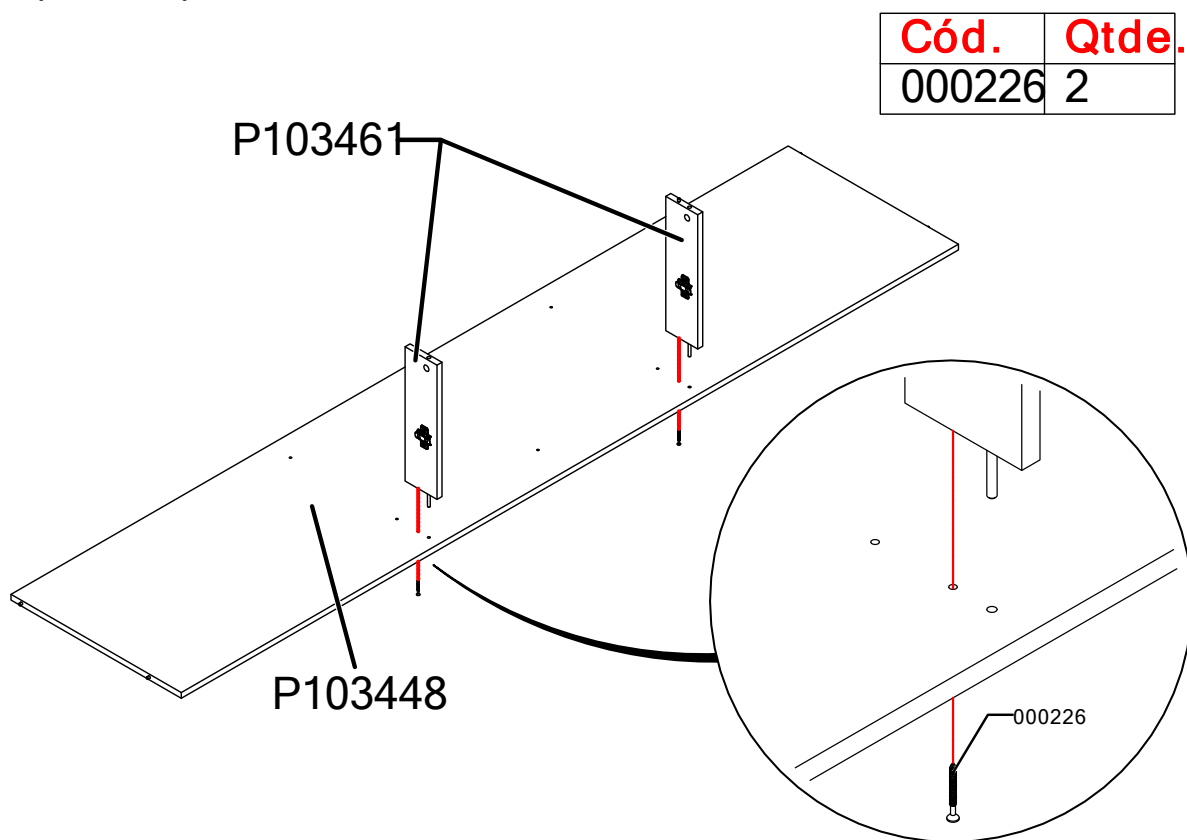

## PASSO / PASO / STEP 29

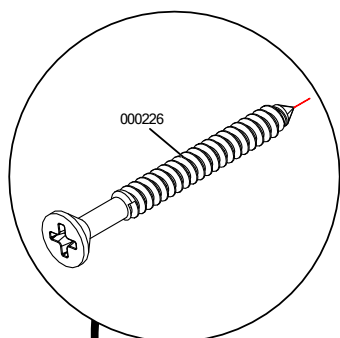

Cód.	Qtde.
000226	6

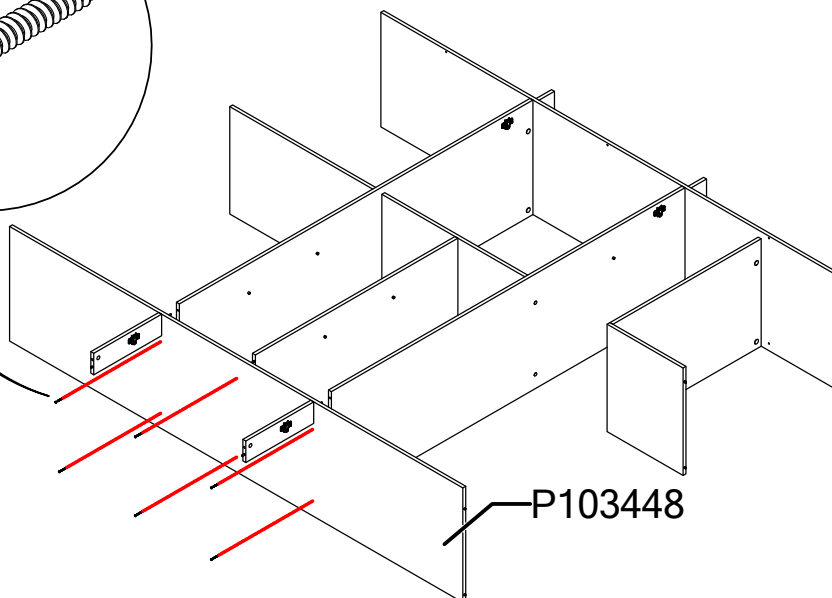

## PASSO / PASO / STEP 30

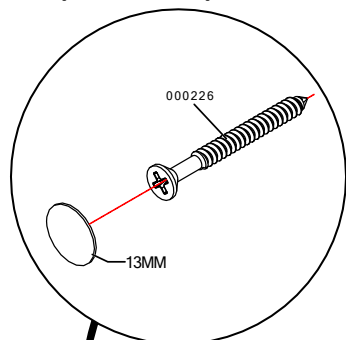

Cód.	Qtde.
004214	16
000899	4
000226	16
13MM	16

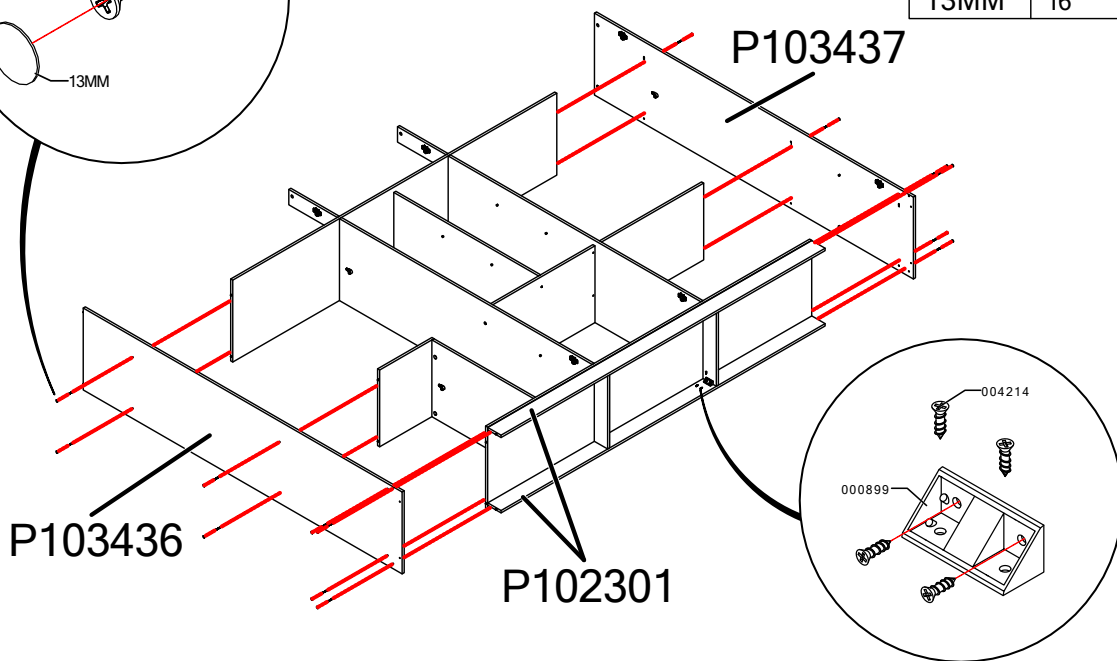

## PASSO / PASO / STEP 31

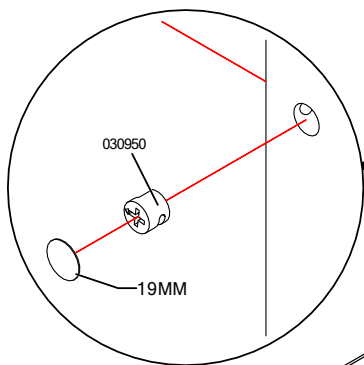

Cód.	Qtde.
030950	6
19MM	6

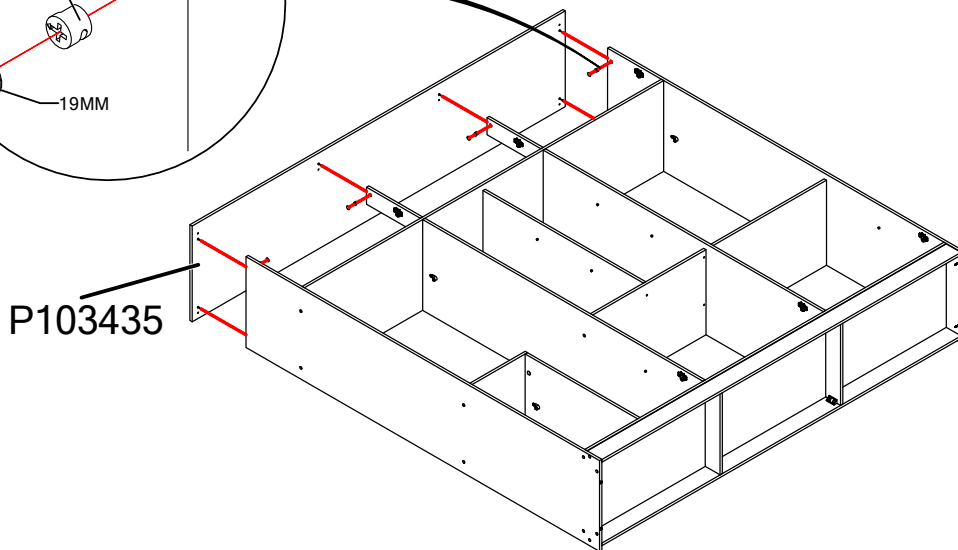

## PASSO / PASO / STEP 32

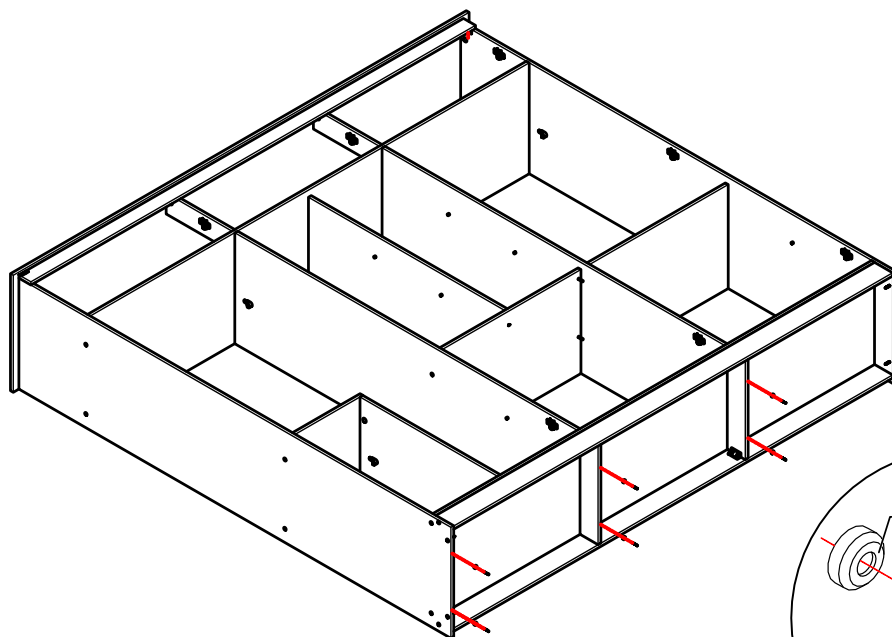

Cód.	Qtde.
001901	8
000108	8

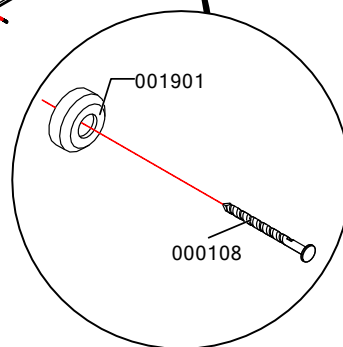



## PASSO / PASO / STEP 33

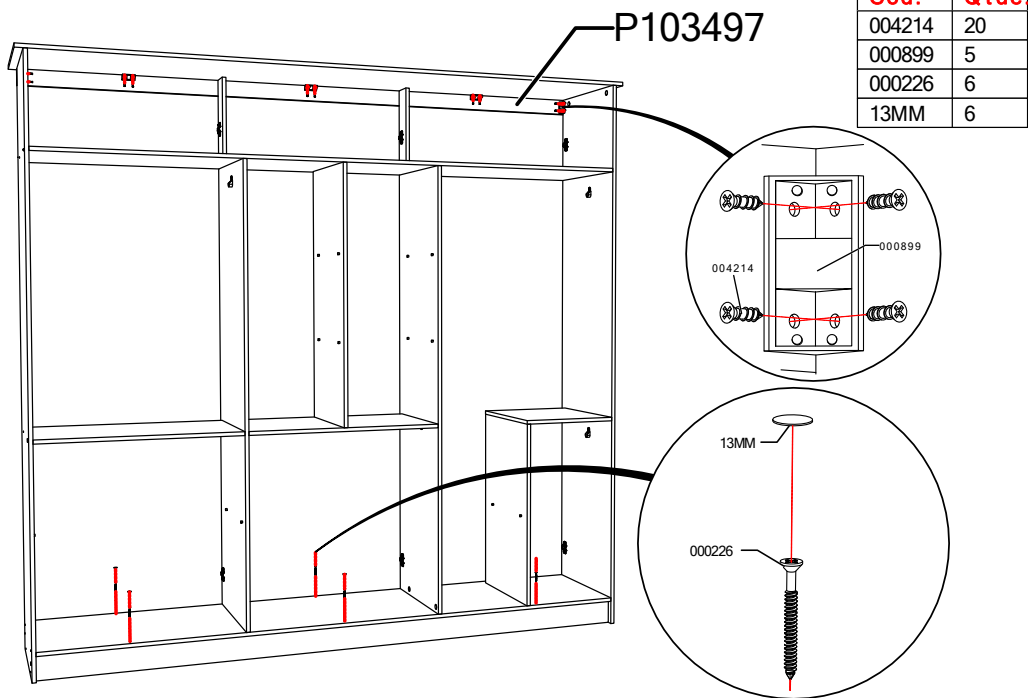

## PASSO / PASO / STEP 34

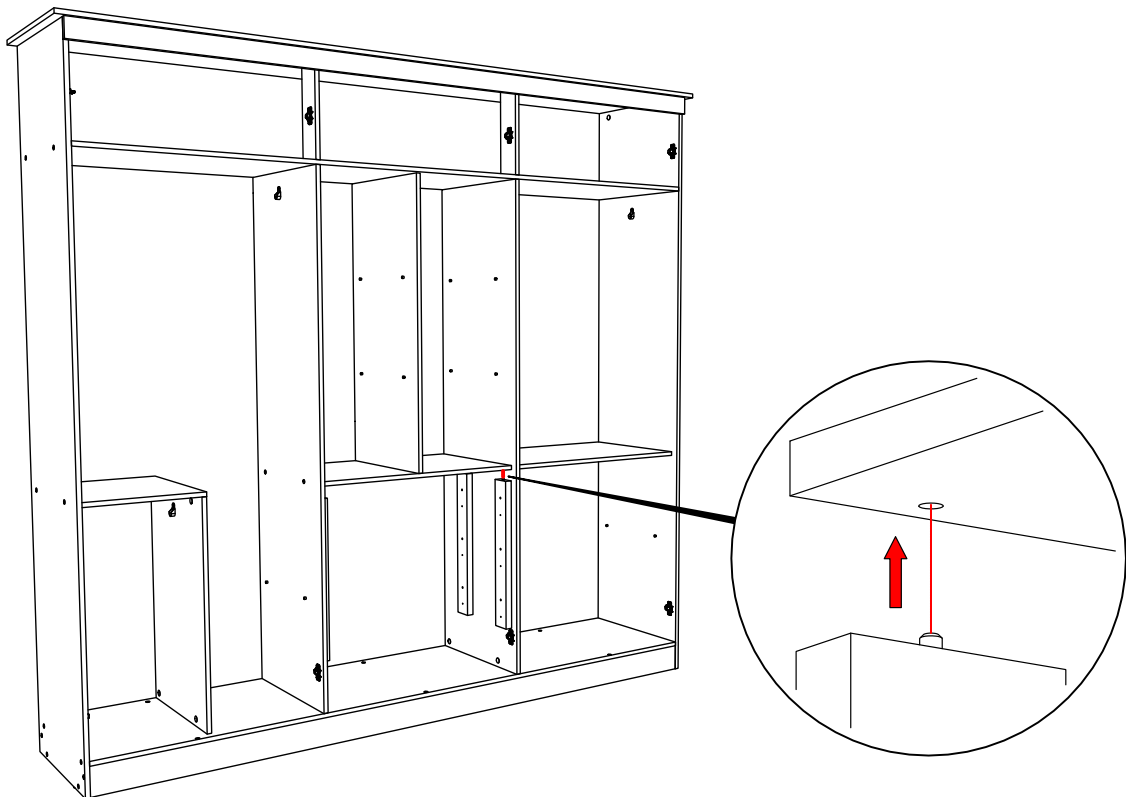

## PASSO / PASO / STEP 35

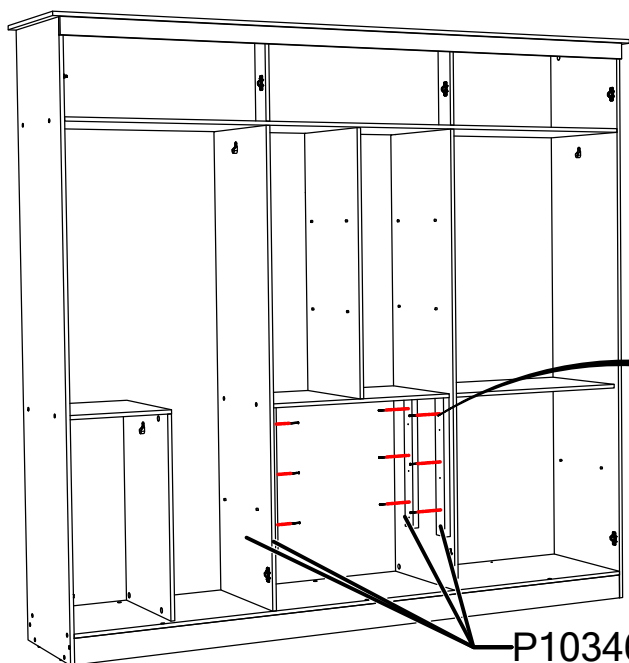

Cód.	Qtde.
000414	12

## PASSO / PASO / STEP 36

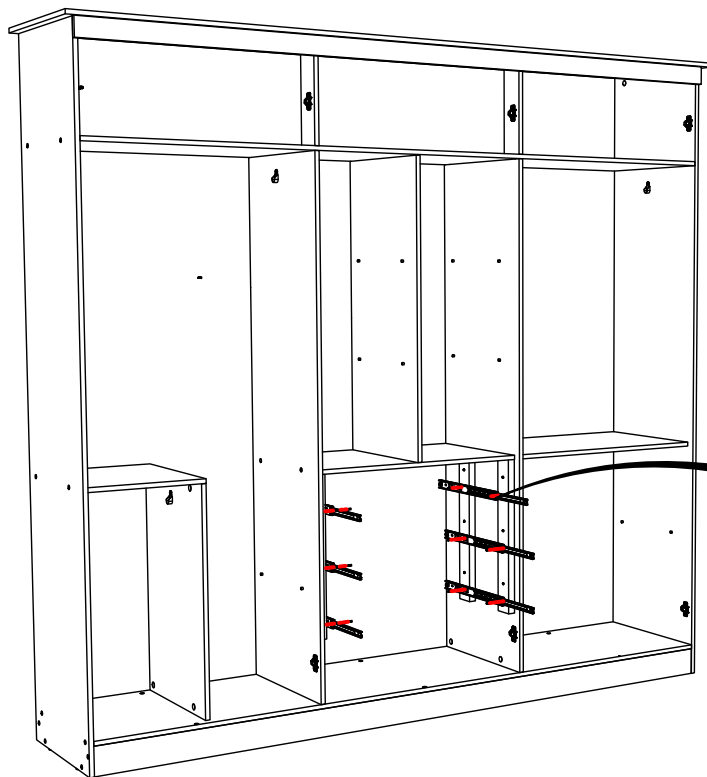

Cód.	Qtde.
038305	3
004214	12

## PASSO / PASO / STEP 37

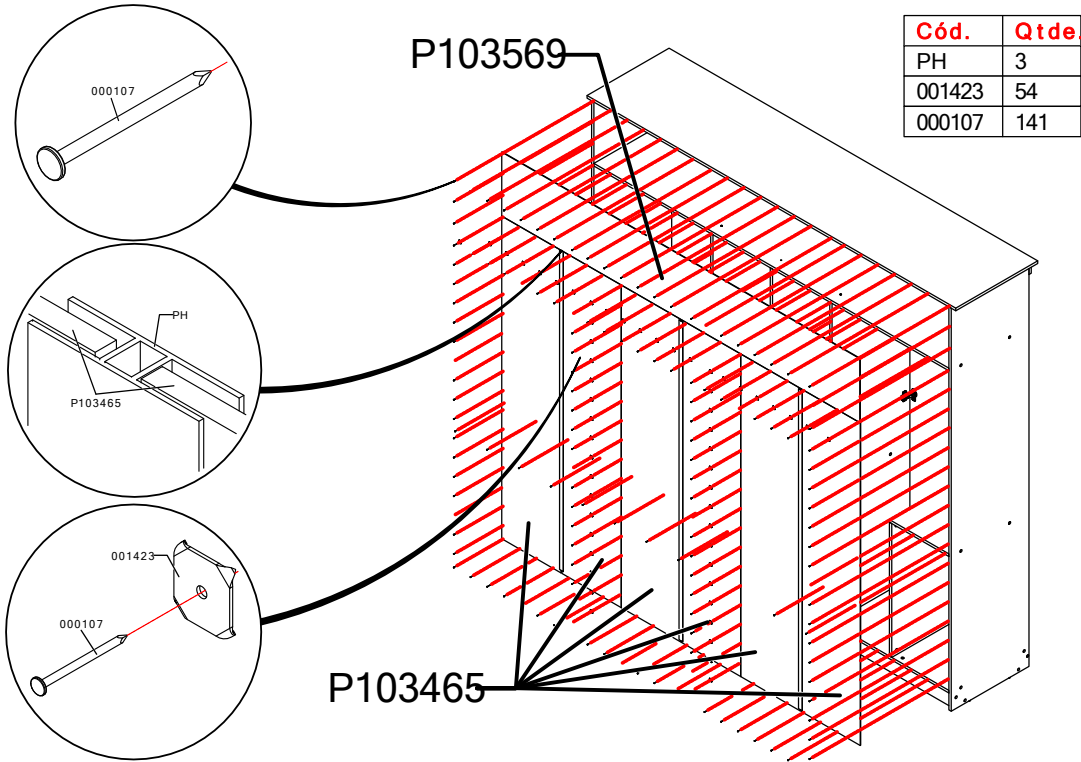

## PASSO / PASO / STEP 38

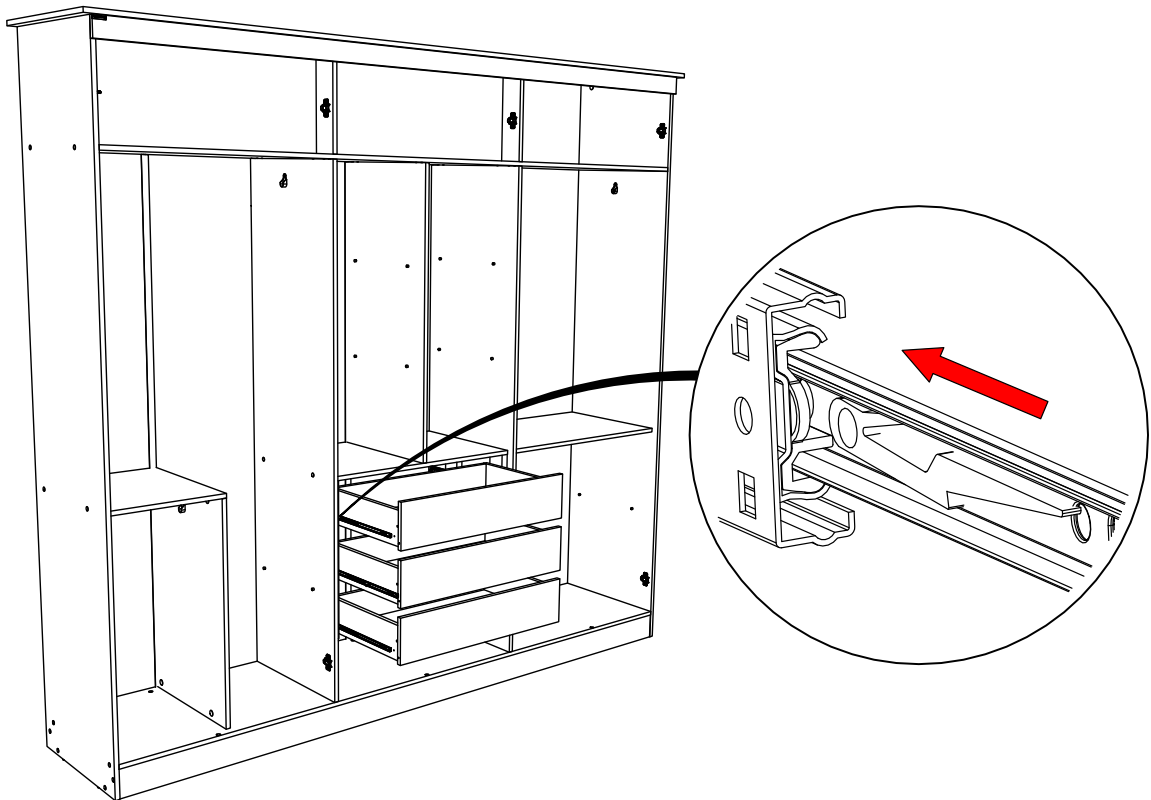

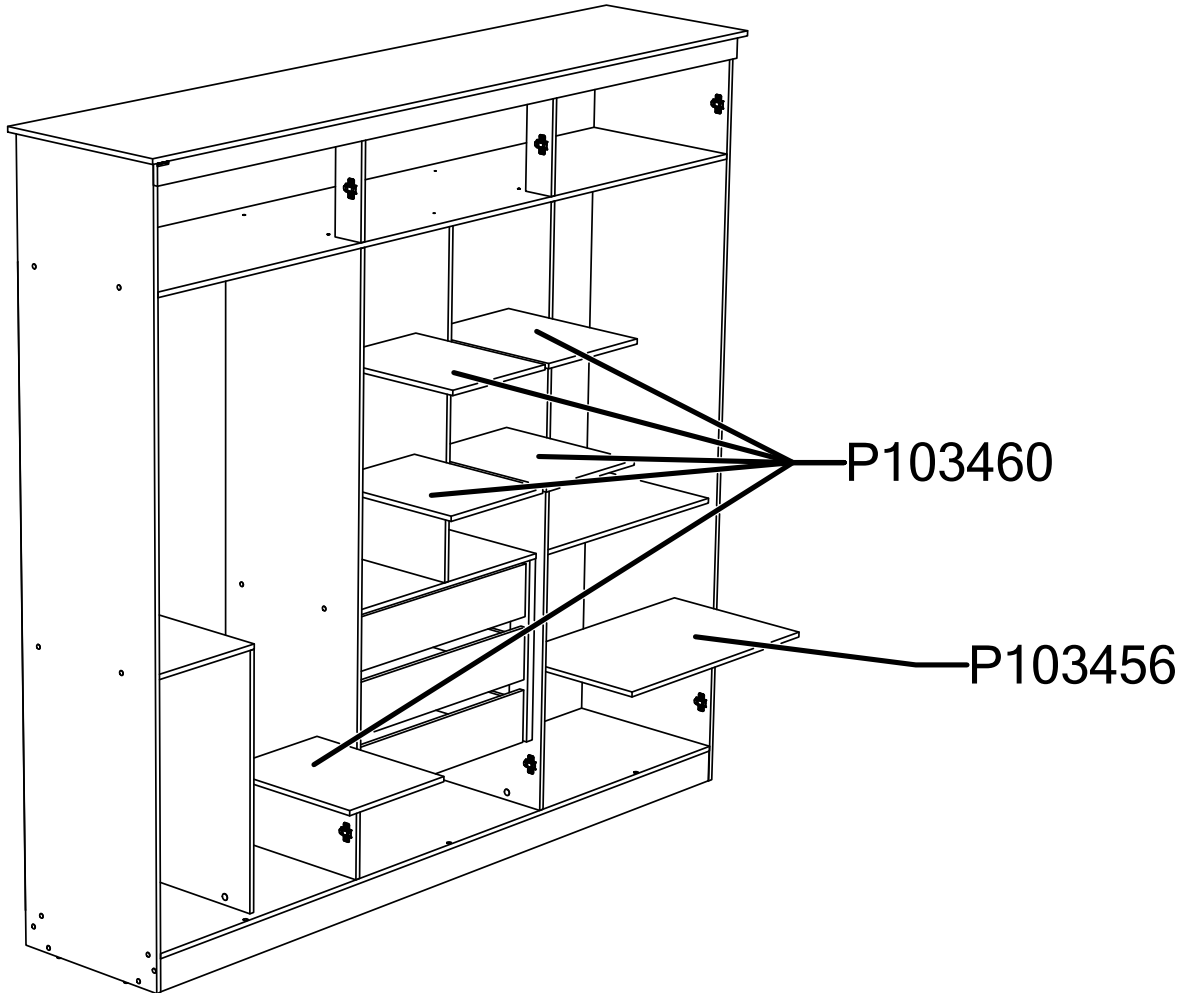

# ***Manual de montagem***

Instrucciones de montaje Assembly instructions

## **PA6AMDF388**

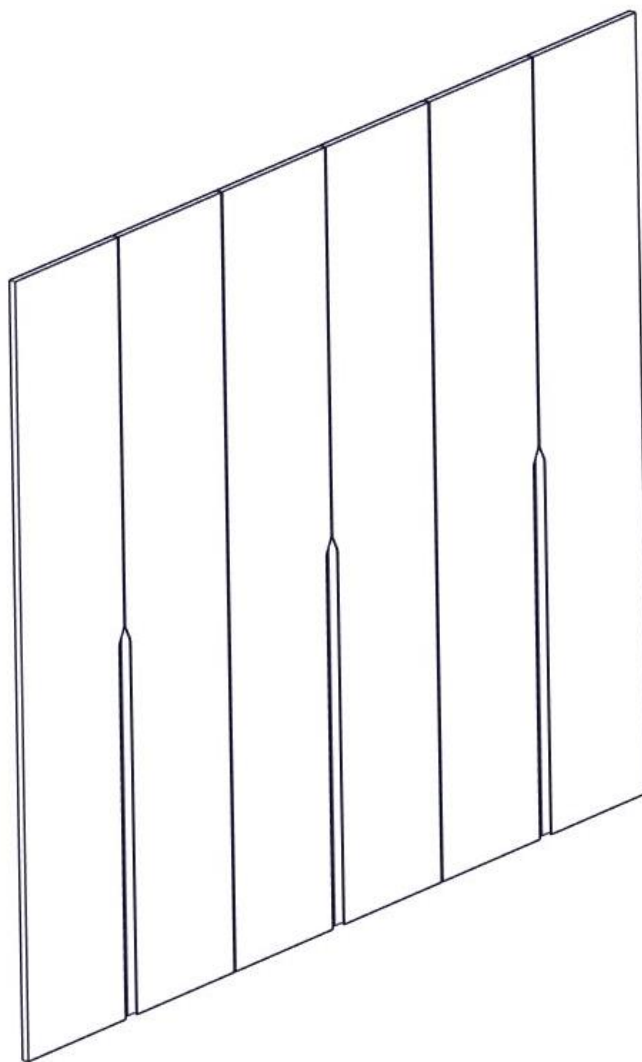

**! Imagens meramente ilustrativas !**  
Imágenes ilustrativas/Images merely illustrative.

Dúvidas? Entre em contato:  
Dudas? Ponerse em contacto:  
Doubts? Get in touch:  
(51) 3635-8839

## A montagem deve ser efetuada por 2 pessoas.

El montaje debe ser efectuada por 2 personas.

The assembly must be done by 2 people.

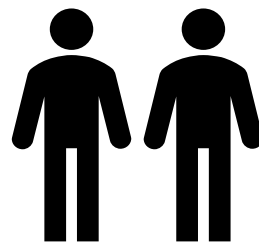

## Ferramentas necessárias para montar o móvel.

Herramientas necesarias para armar el mueble.

Tools needed to assemble the furniture.



## Dúvidas? Entrar em contato:

Dudas? Ponerse en contacto:

Doubts? Get in touch:

Fone: (51) 3635-8839

[www.kappesberg.com.br](http://www.kappesberg.com.br)



## Montar o móvel sobre uma superfície limpa e plana.

Armar el mueble sobre una superficie limpia y plana.

Assemble the furniture on a clean, flat surface.

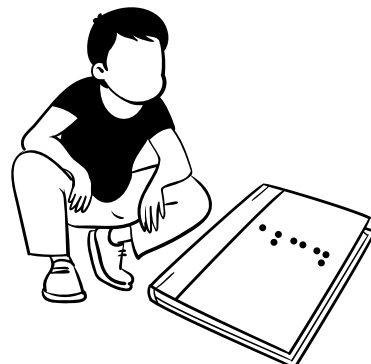

**IDENTIFICAÇÃO DAS PEÇAS / IDENTIFICACIÓN DE LAS PIEZAS PARTS  
IDENTIFICATION**

QTD.	CÓDIGO / CODE	DESCRIÇÃO	Descripción	Description	C x L x E	L x W x T
6	P105140	PORTA	PUERTA	DOOR	2126 x 388 x 18 mm	83.70 x 15.28 x 0.71 in

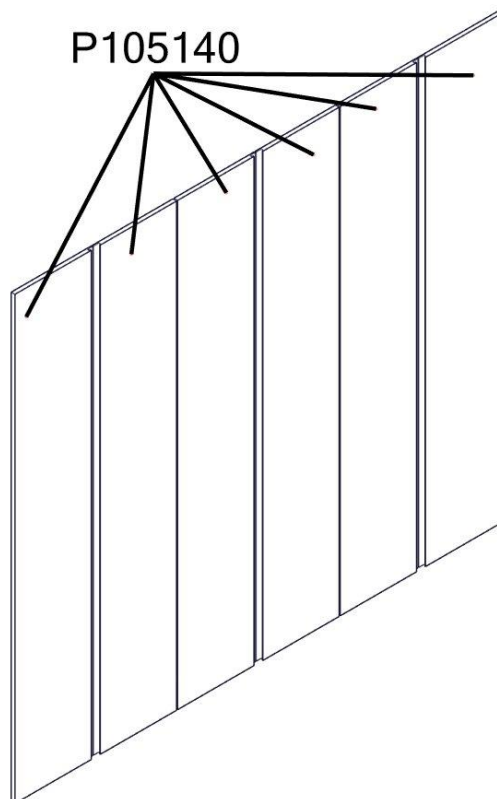

**Atenção:** Na embalagem do corpo, acompanham os acessórios de dobradiças para a montagem do produto.

**Atención:** Los accesorios de bisagra para montar el producto se incluyen en el embalaje del módulo.

**Attention:** The hinge accessories for assembling the product are included in the module's packaging.

## PASSO / PASO / STEP 1

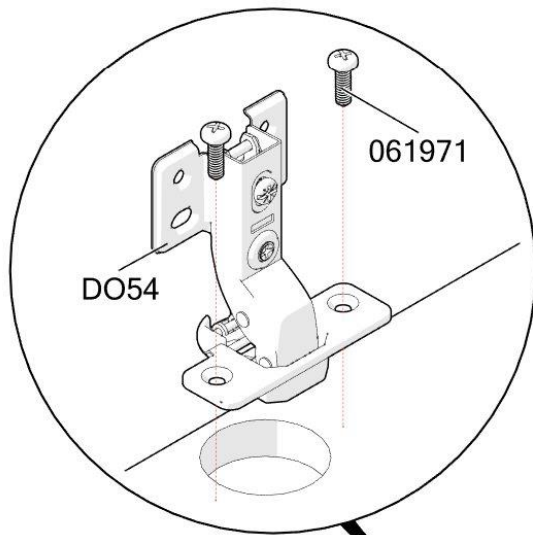

Cód.	Qtde.
061971	36
DO54	18

