

# Gelius

---

*roupeiro | ropero | wardrobe*

## ***ARES***

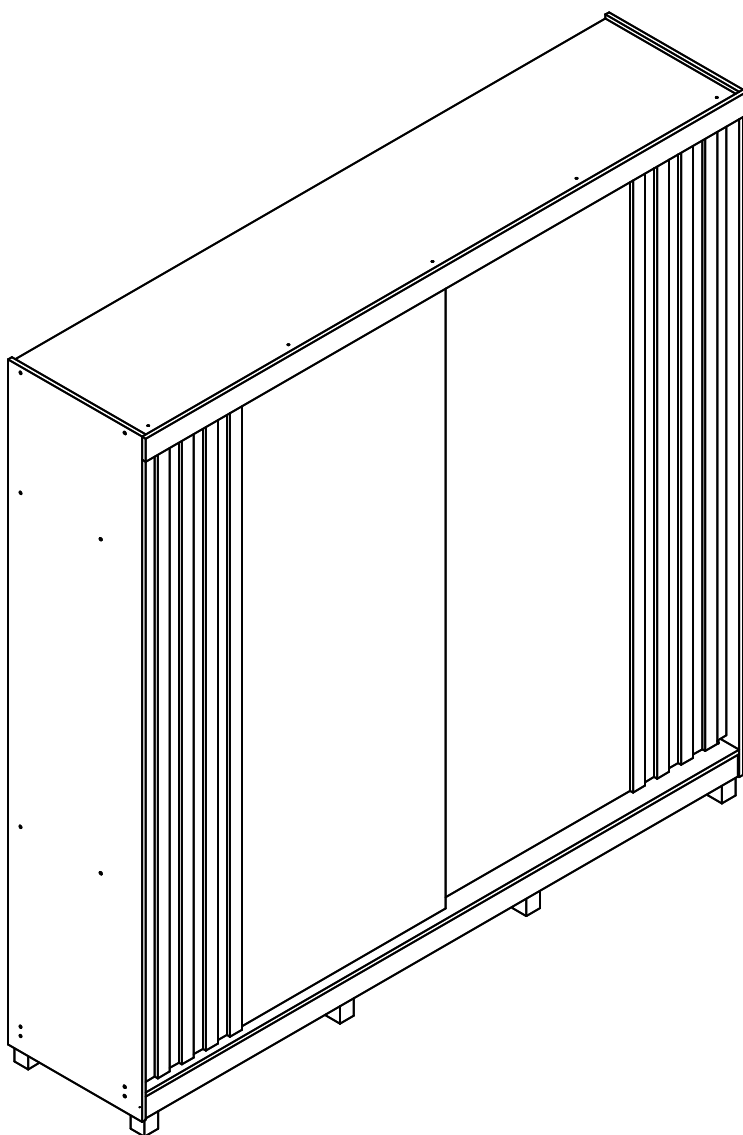

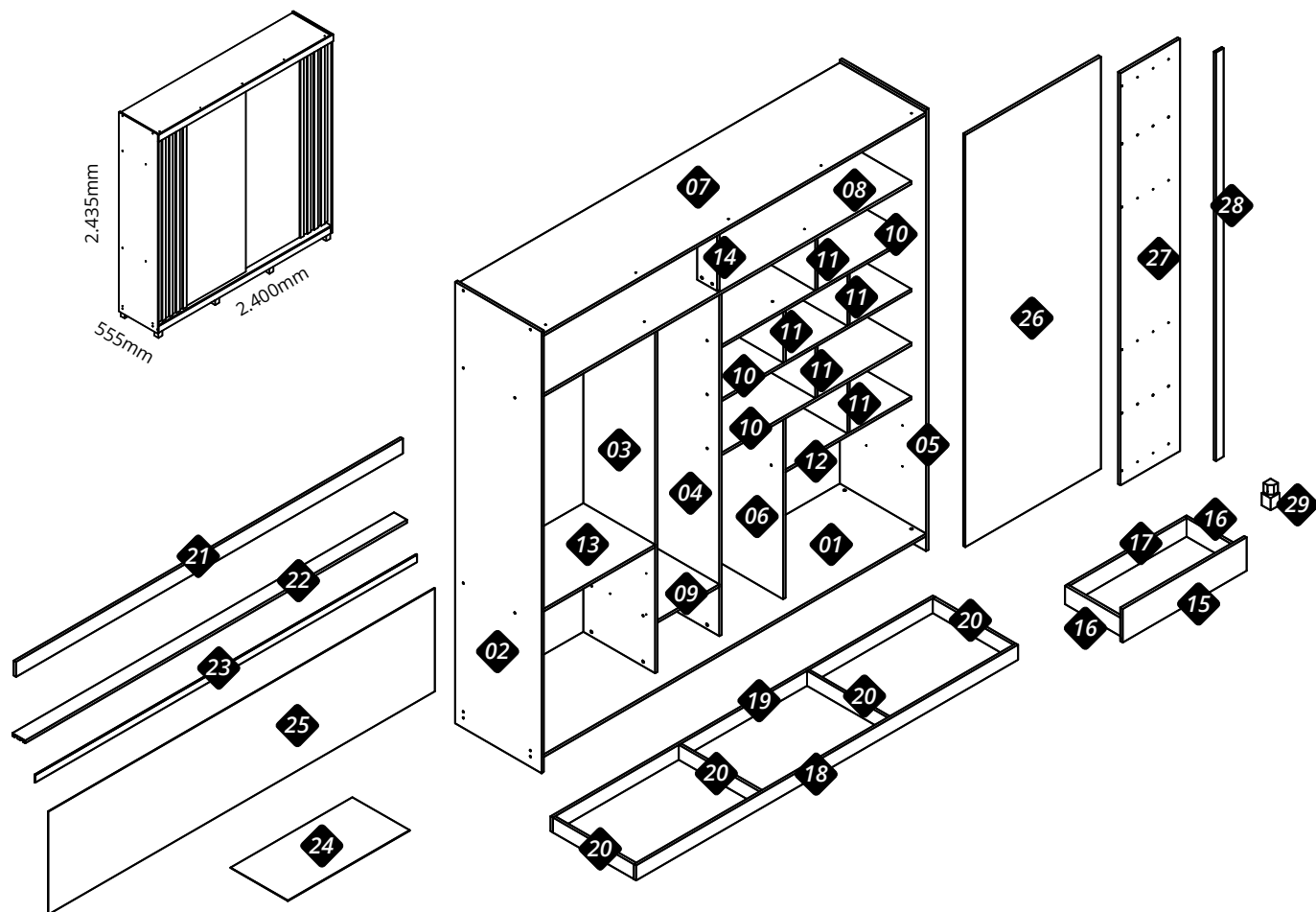

Nº	Cód.	Peças	Piezas	Parts	Medida / Size	Qtd.	Vol.
01	07977	Base	Base	Base	2370x535x15	01	03
02	07979	Lateral esquerda	Lateral izquierda	Left side	2370x535x15	01	02
03	07983	Divisória esquerda	División izquierda	Left division	1840x445x15	01	04
04	07982	Divisória central	División central	Central division	1840x445x15	01	01
05	07980	Lateral direita	Lateral derecha	Right side	2370x535x15	01	02
06	07989	Lateral gaveteiro	Lateral del cajonera	Side of the drawer	973x445x15	01	02
07	07978	Tampo	Cubierta	Top	2370x535x15	01	03
08	07981	Tampo intermediario	Cubierta intermediario	Intermeriary top	2370x445x15	01	04
09	07984	Prateleira menor	Estante menor	Smaller shelf	382x445x15	01	04
10	07985	Prateleira do nicho	Estante del nicho	Niche shelf	1177x445x15	03	01
11	07986	Divisória do nicho	División del nicho	Niche divider	274x445x15	05	04
12	07987	Prateleira da gaveta direita	Estante del cajonera derecha	Shelf of drawer right	780x445x15	01	02
13	07988	Prateleira da gaveta esquerda	Estante del cajonera izquierda	Shelf of drawer left	780x445x15	01	04
14	07990	Divisória superior	División superior	Upper division	355x124x15	01	04
15	07991	Frente de gaveta	Frente del cajon	Front of drawer	770x180x15	04	01
16	07992	Lateral de gaveta	Lateral de cajon	Side panel of the drawer	350x100x15	08	01
17	07993	Contra fundo de gaveta	Trasero del cajon	Rear panel of the drawer	725x100x15	04	01
18	07994	Rodapé frontal	Rodapie frontal	Lower front crossbar	2370x80x15	01	04
19	07995	Rodapé traseiro	Rodapie trasero	Lower rear crossbar	2370x80x15	01	04
20	07996	Trava do rodapé	Traba del rodapie	Smaller crossbar	500x80x15	04	01
21	07997	Moldura superior	Marco superior	Top frame	2400x82x15	01	04
22	07998	Trilho superior	Carril superior	Upper rail	2368x80x15	01	02
23	07999	Perfil H	Perfil H	Profile H	2368x40x06	03	04
24	08000	Fundo de gaveta	Fondo del cajone	Bottom off the drawer	755x355x2,5	04	01
25	08001	Fundo traseiro	Fondo trasero	Rear bottom	2398x545x2,5	04	03
26	07972	Porta maior	Puerta más mayor	Bigger door	2190x840x15	02	01
27	07973	Porta menor	Puerta menor	Smaller door	2190x370x15	02	02
28	07974	Ripa	Ripia	Lath	2170x48x12	08	02
29	*	Kit Pé	Kit Pie	Foot kit		08	01

Recorte aqui e guarde seu certificado de garantia!

# Certificado de garantia

A Gelius Indústria de Móveis confia na qualidade de seus produtos e por isso o garante pelo prazo de 90 dias para defeitos de fabricação em condições normais de uso.

Resultarão nula a garantia e sem efeito a cobertura, se o produto, (incluindo vidros e ou espelhos que o compõe):

- sofrer dano provocado por acidente, agente da natureza.
- uso indevido ou maus tratos como arrastar, subir em cima, colocar produtos com excesso de peso).
- não utilizado para os fins a que se destina.
- conter manchas provocadas por uso de produtos químicos em sua limpeza.
- excesso de umidade ou água.

Ao detectar qualquer defeito em seu móvel, entre em contato com a loja onde foi efetuada a compra. A comprovação de que o móvel a ser consertado ou substituído encontra-se dentro do prazo de garantia é de total responsabilidade do fabricante e deve ser feita mediante a apresentação desse certificado corretamente preenchido e sem rasuras ou resalvas.

Cuidados com seu móvel Gelius!

- para limpeza do seu móvel, utilize apenas pano macio e seco.
- jamais limpe-o com palha de aço, álcool ou qualquer outro produto químico ou abrasivos, óleos de peroba ou produtos do gênero.
- evite deixá-lo sob raios solares ou chuva.
- ao transportar o seu móvel Gelius, prenda-o firmemente para que não ocorra quedas indesejáveis.

Seguindo corretamente as informações acima, você conservará por muito mais tempo o seu móvel Gelius!

GARANTIA DO CLIENTE:

Cliente: \_\_\_\_\_

Rua: \_\_\_\_\_ Nº: \_\_\_\_\_ Bairro: \_\_\_\_\_

Cidade: \_\_\_\_\_ UF: \_\_\_\_\_ Loja onde comprou: \_\_\_\_\_

Data da compra: \_\_\_\_/\_\_\_\_/\_\_\_\_ Nota Fiscal: \_\_\_\_\_

Data da reclamação na loja: \_\_\_\_/\_\_\_\_/\_\_\_\_

Defeito constante: \_\_\_\_\_

## Recomendações | Recomendaciones | Recommendations

**Atenção**  
Atención  
Attention

**Este produto deve ser montado por um profissional.**

Este producto debe ser ensamblado por un profesional.

This product must be assembled by a professional.

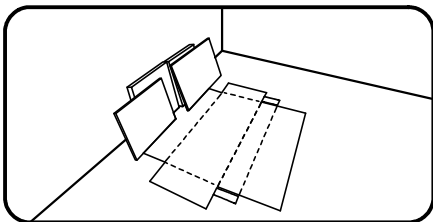

**Antes de começar a montagem prepare o ambiente, deixando-o completamente limpo e com bom espaço para iniciar o trabalho. Utilize o papelão da própria embalagem para separar e apoiar as peças retiradas da caixa.**

Antes de comenzar el montaje preparar el ambiente, dejándolo completamente limpio y con buen espacio para comenzar el trabajo. Utilice el cartón de la embalaje para separar y apoyar las piezas desmontadas de las cajas.

Prepare the room before starting the assembly, leaving it completely clean and the area in good condition to start the work. Use the cardboard of the packaging to separate and support the parts removed from the boxes.

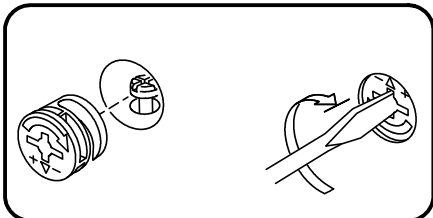

**Como usar o acessório Pino e Tambor Minifix (quando utilizado no produto).**

Como usar el herraje Pino y Tambor Minifix (cuando se usa en el producto).

How to use the Minifix Set (when used in the product).

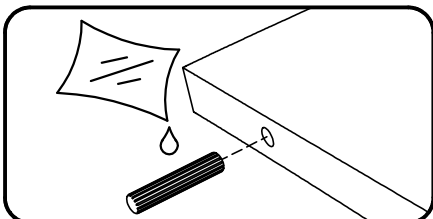

**Aplicar cola nas cavilhas de madeira (quando utilizado no produto).**

Aplicar pegamento a las clavijas de madera (cuando se usa en el producto).

Apply glues to the wooden dowels (when used in the product).

Ferramentas recomendadas para montagem | Herramientas de montaje recomendadas | Recommended tools

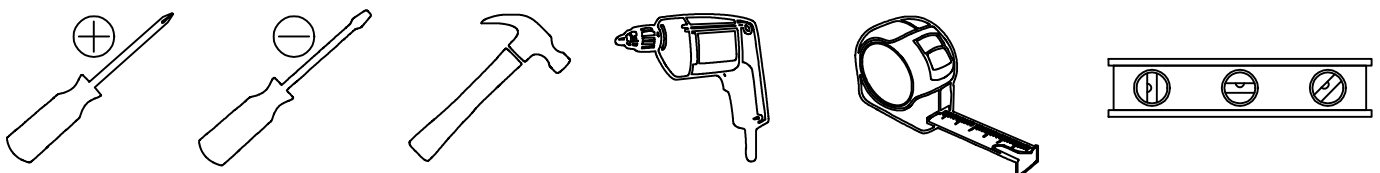

## Acessórios e ferragens | Herrajes | Hardware

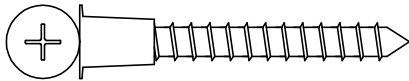

A - cód. 30017779 074 un.



B - cód. 30014538 144 un.

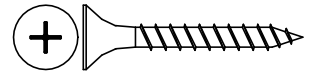

C - cód. 30000716 004 un.

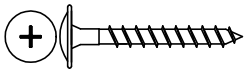

D - cód. 30000843 037 un.



E - cód. 30014537 140 un.

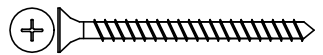

F - cód. 30001098 024 un.

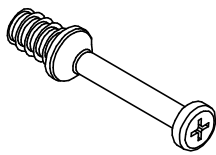

G - cód. 30006753 030 un.

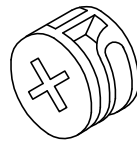

H - cód. 30001073 030 un.

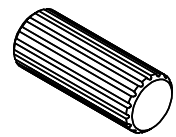

I - cód. 30016093 016 un.

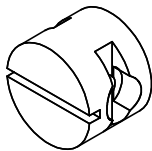

J - cód. 30008479 008 un.

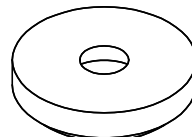

K - cód. 30000853 008 un.



L - cód. 30000783 150 un.

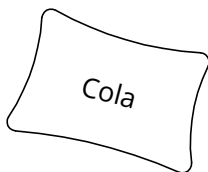

M - cód. 30000790 001 un.

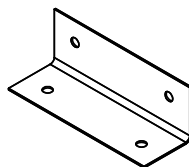

N - cód. 30003829 018 un.

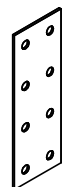

O - cód. 30019727 010 un.

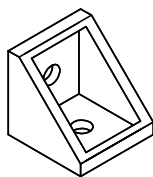

P - cód. 30015224 005 un.

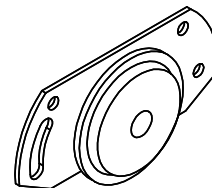

Q - cód. 30019581 001 un.

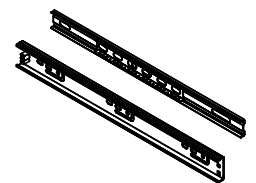

R - cód. 30013843 004 un.

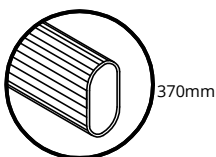

S - cód. 30019579 002 un.

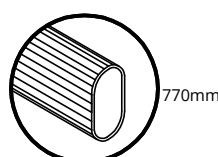

T - cód. 30014154 001 un.

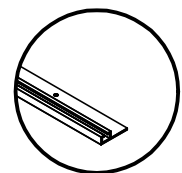

U - cód. 30019726 002 un.

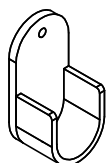

V - cód. 30001188 006 un.

01

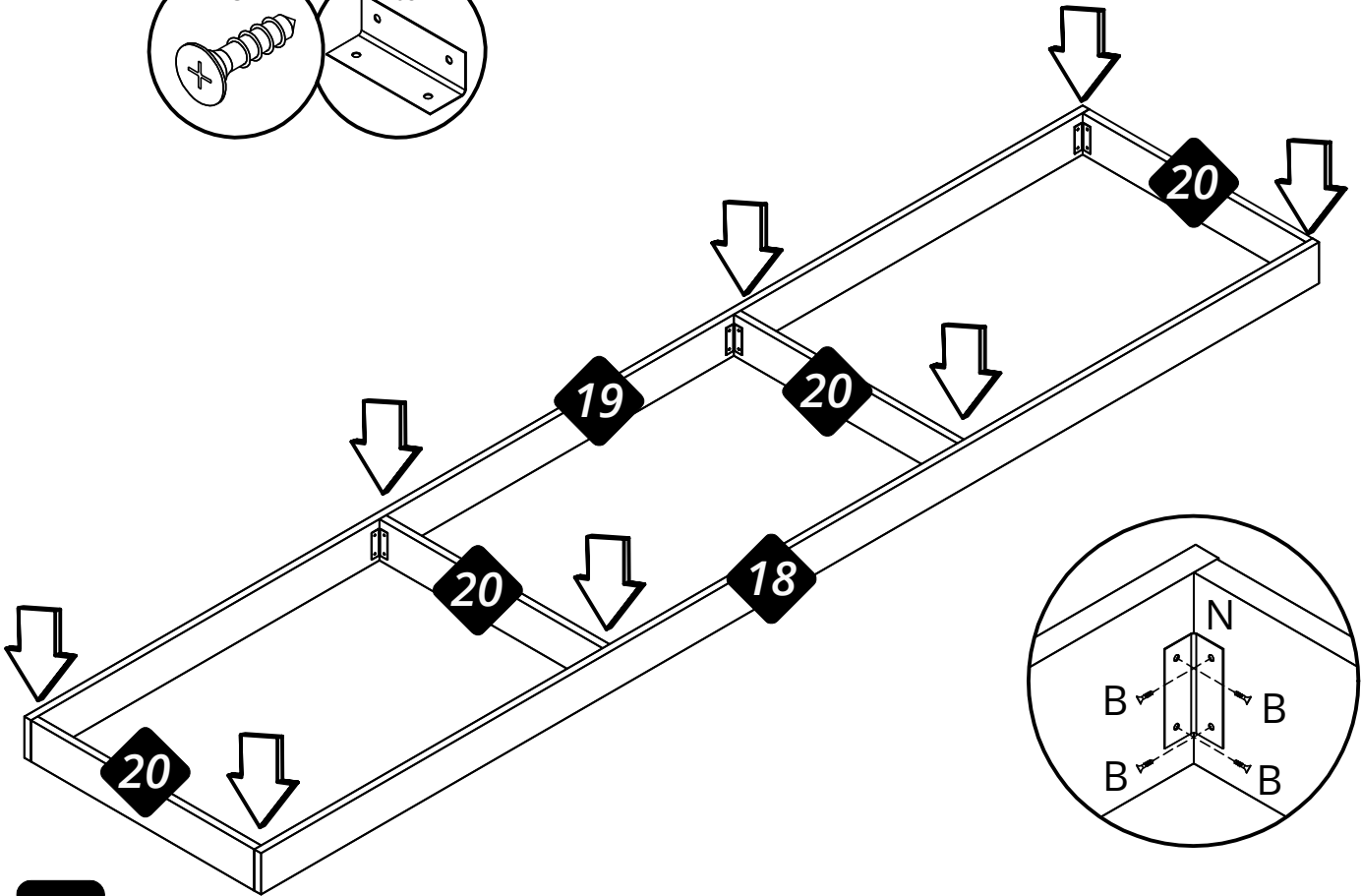
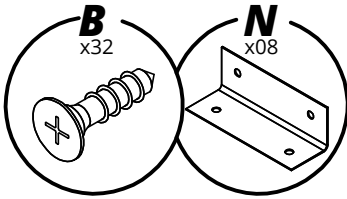

02

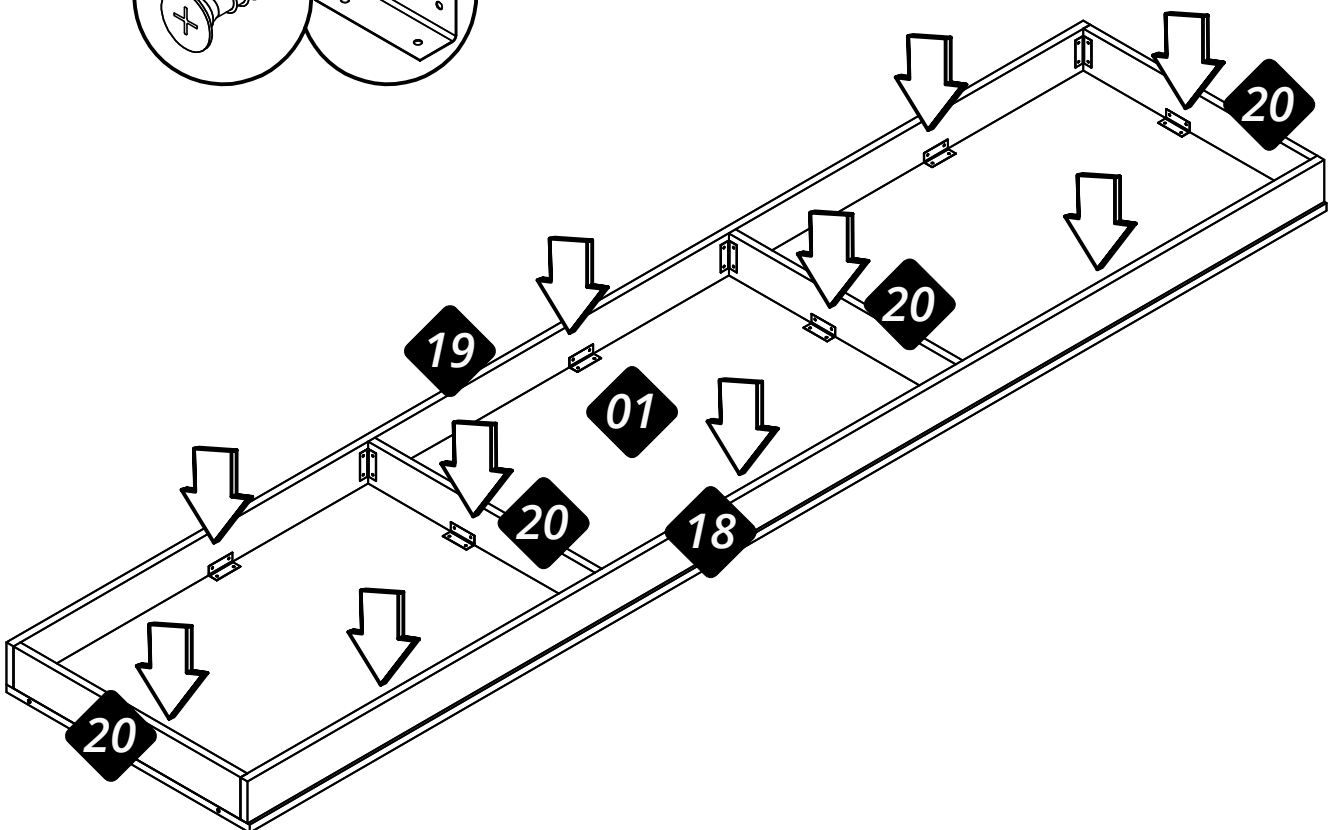
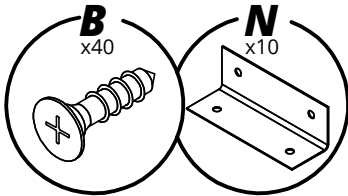

03

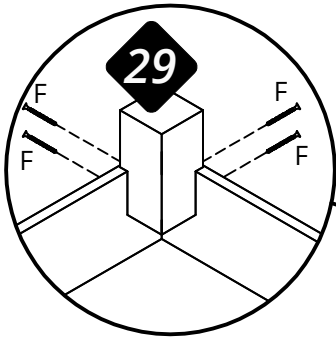

Atenção: Parte de trás

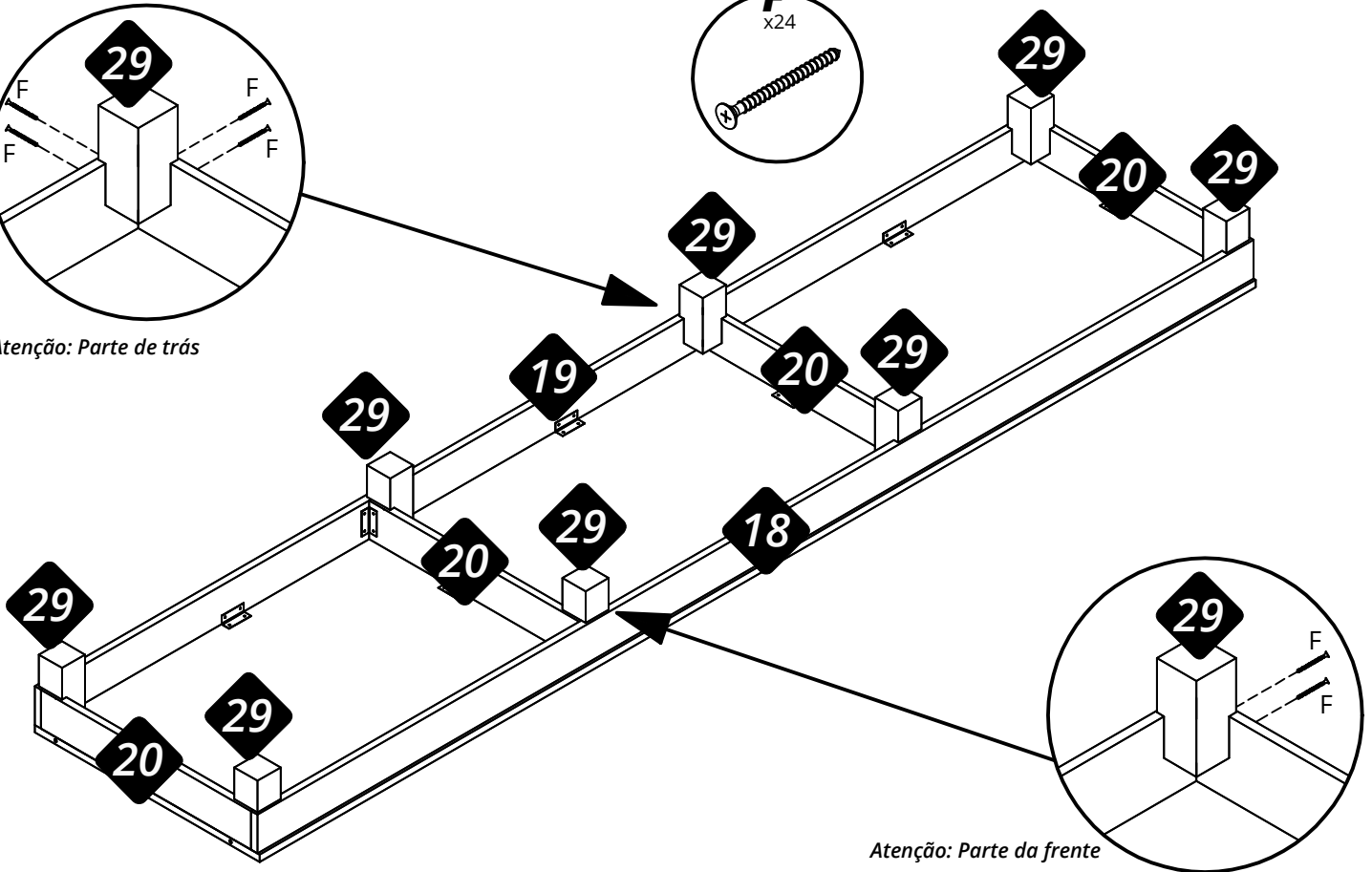
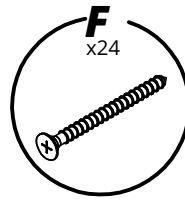

Atenção: Parte da frente

04

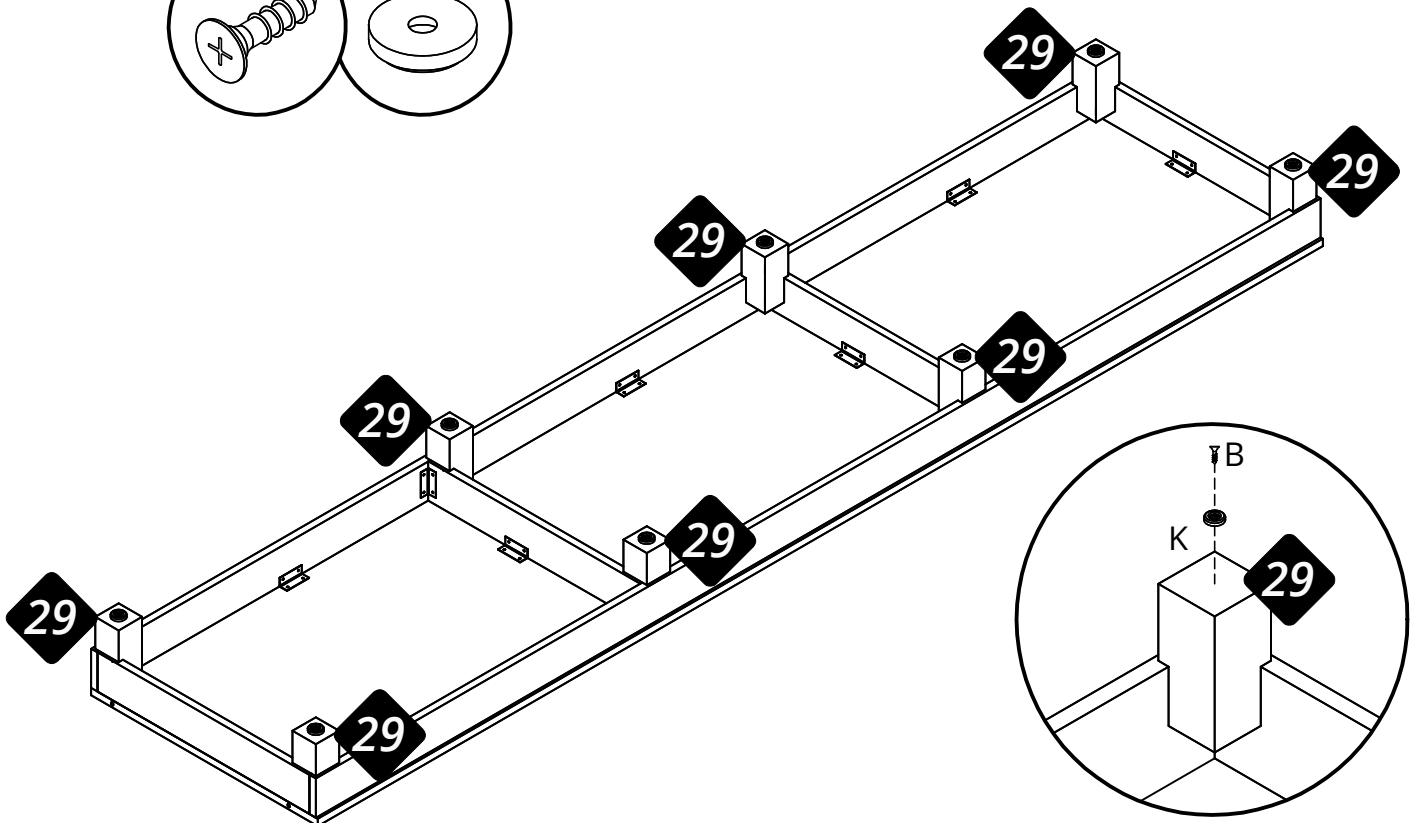
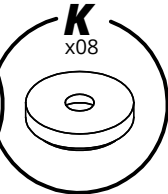
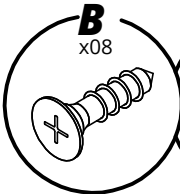

05

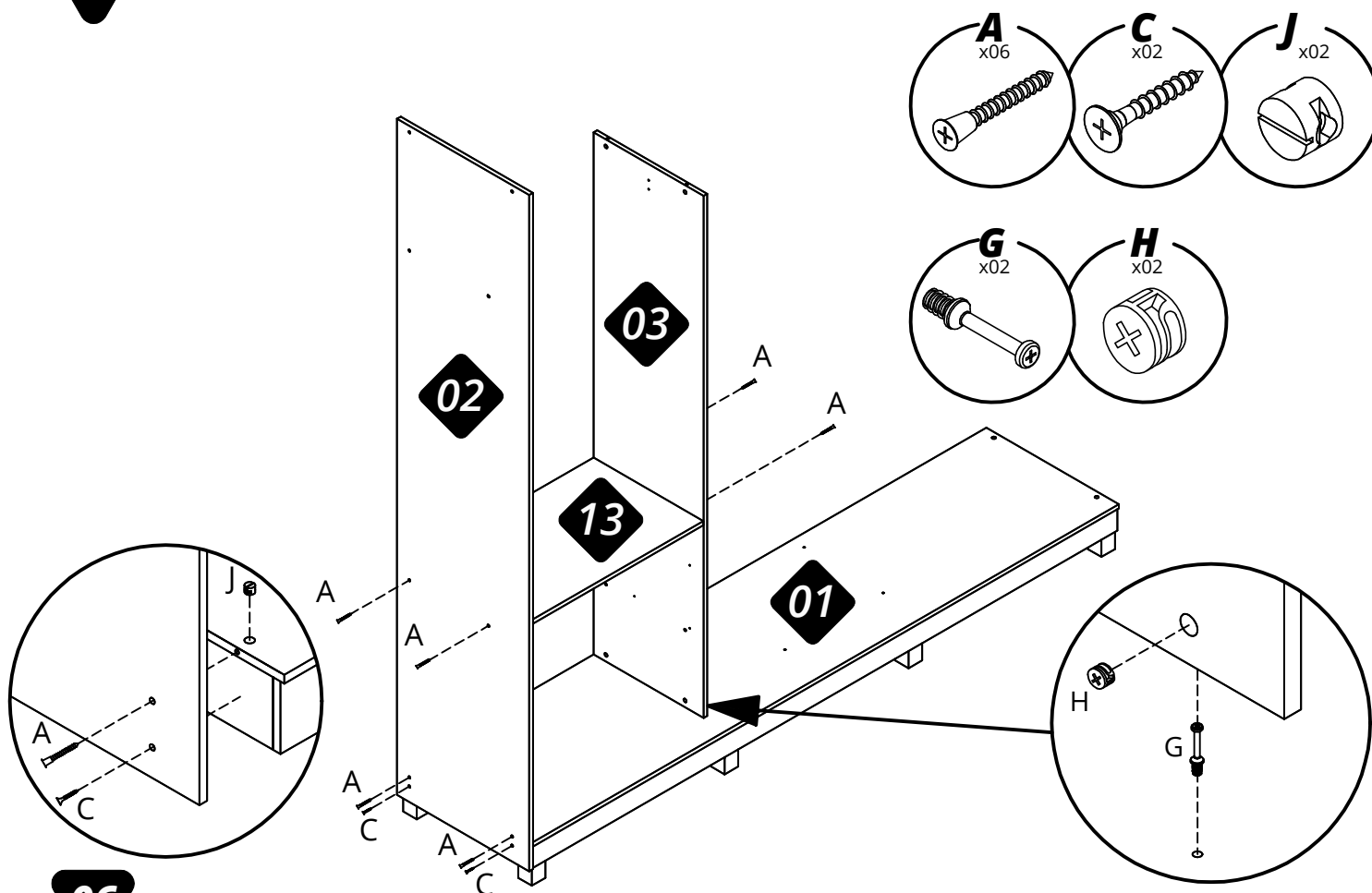

06

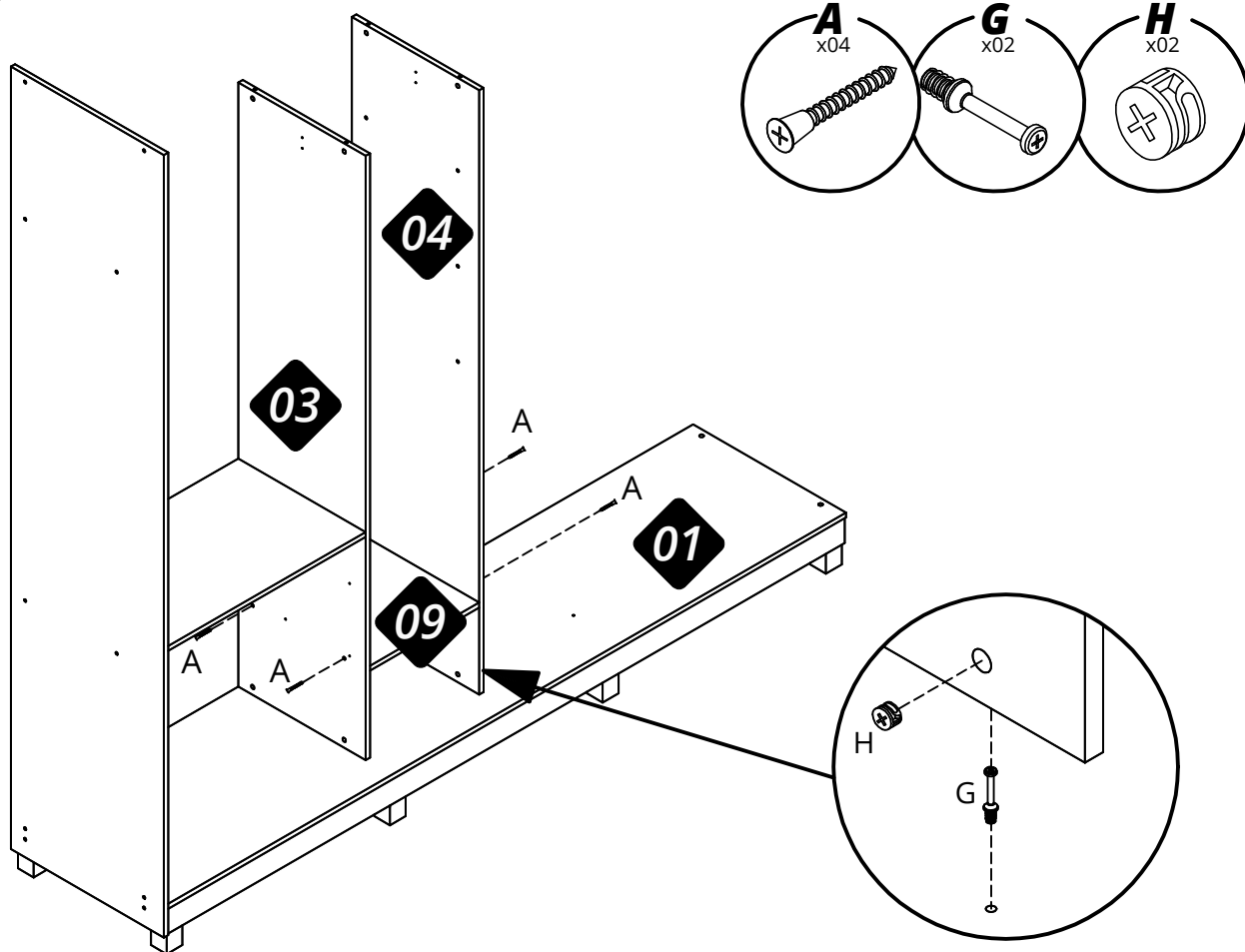

07

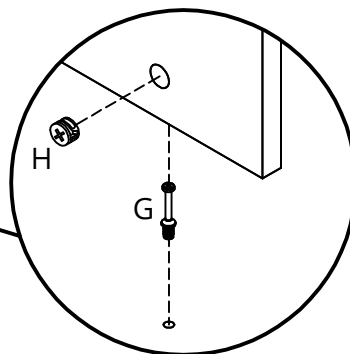
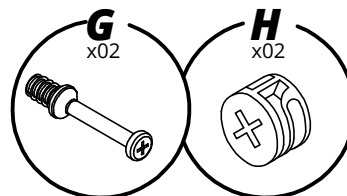
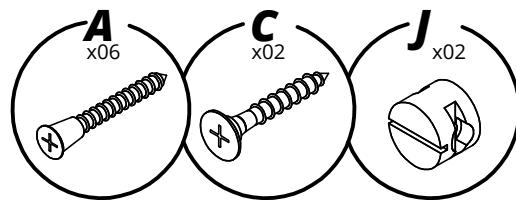
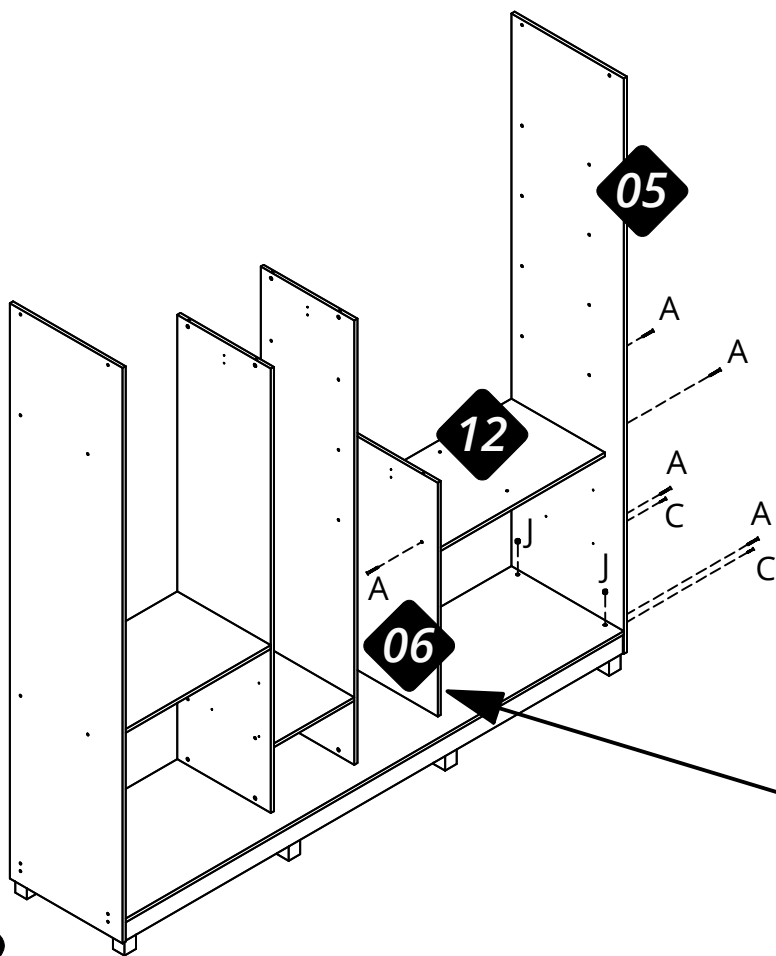

08

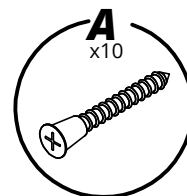
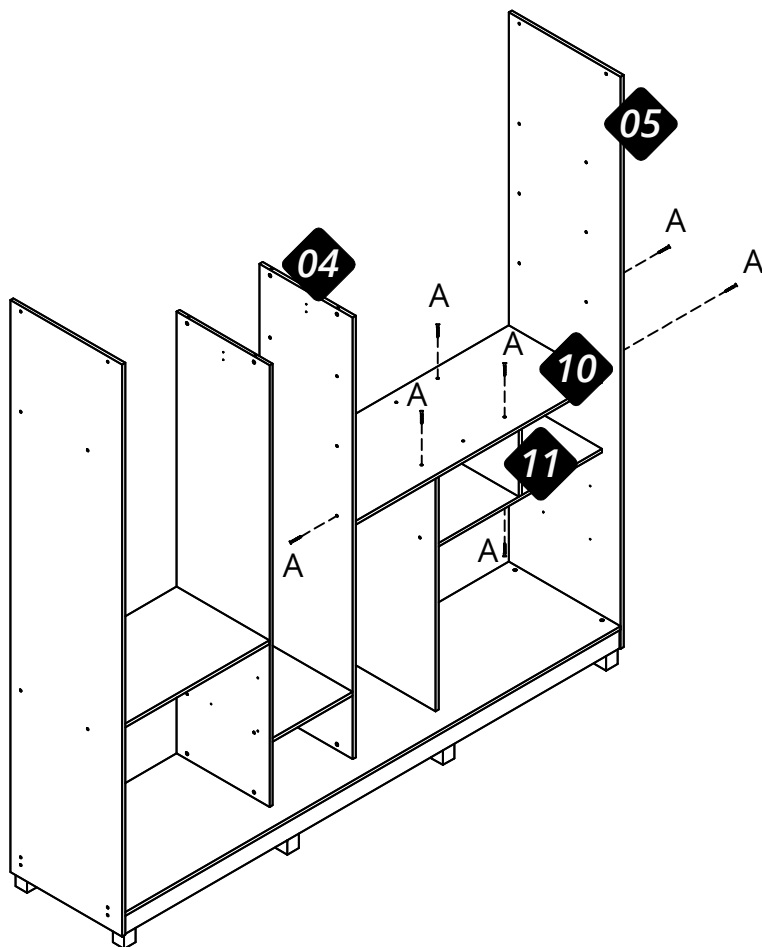



09

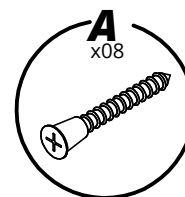
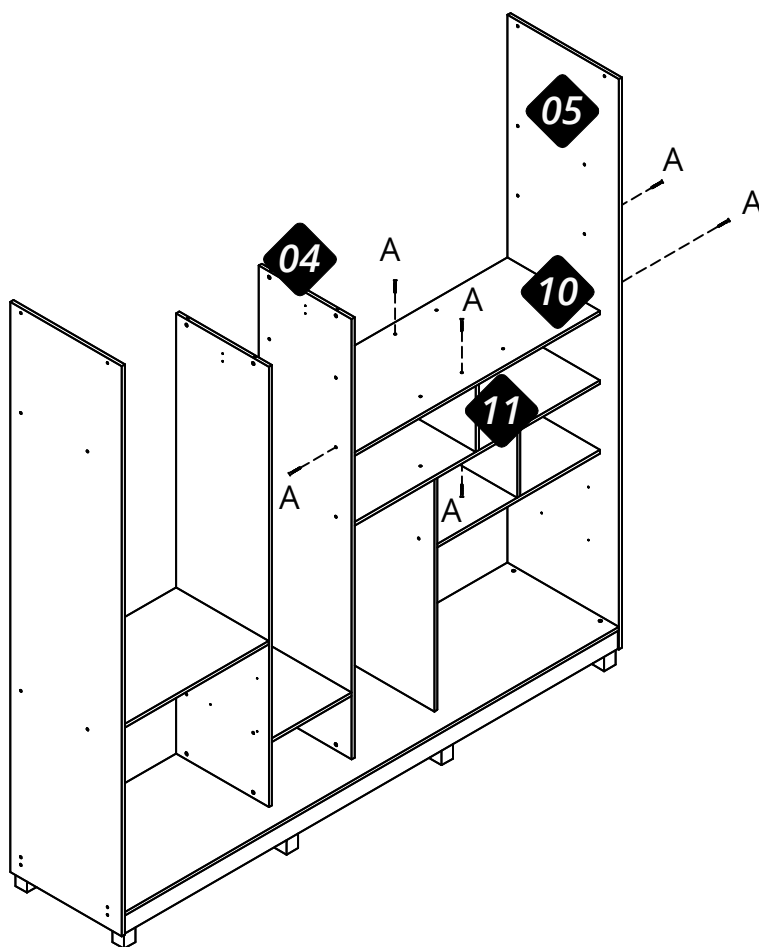

10

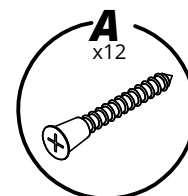
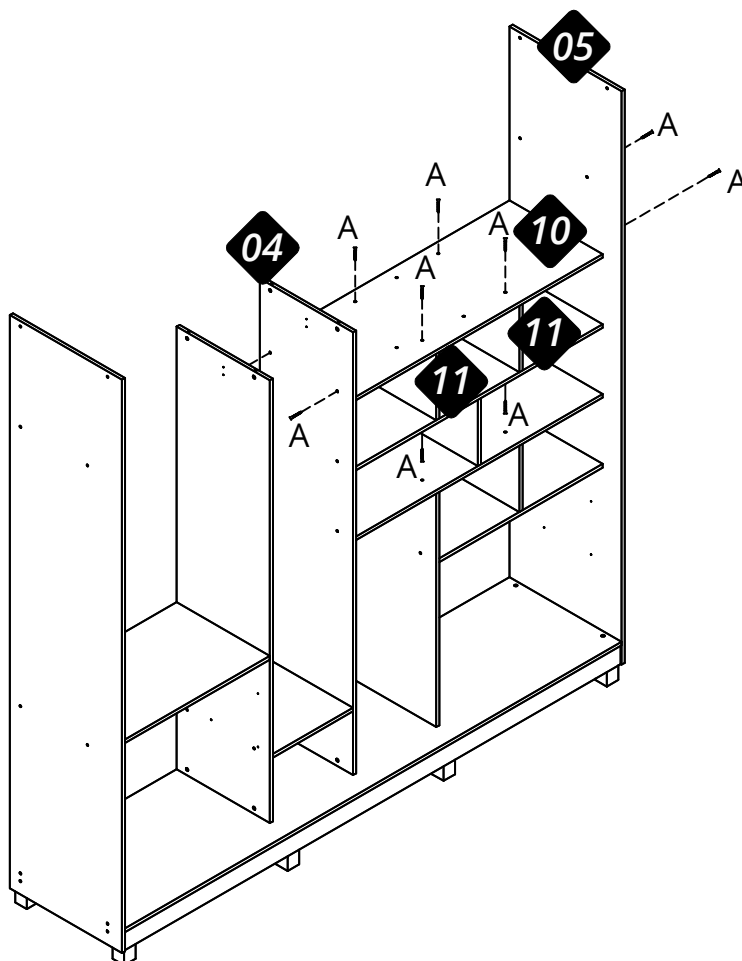

11

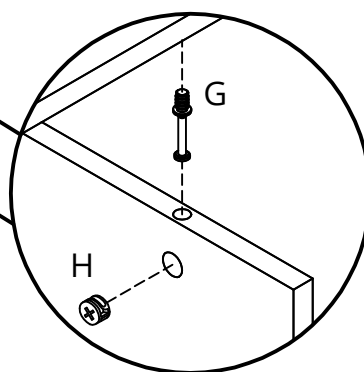
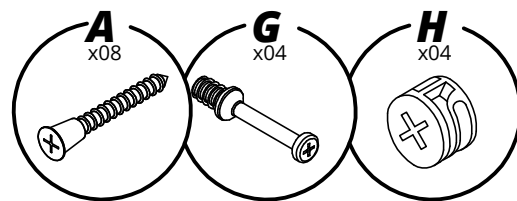
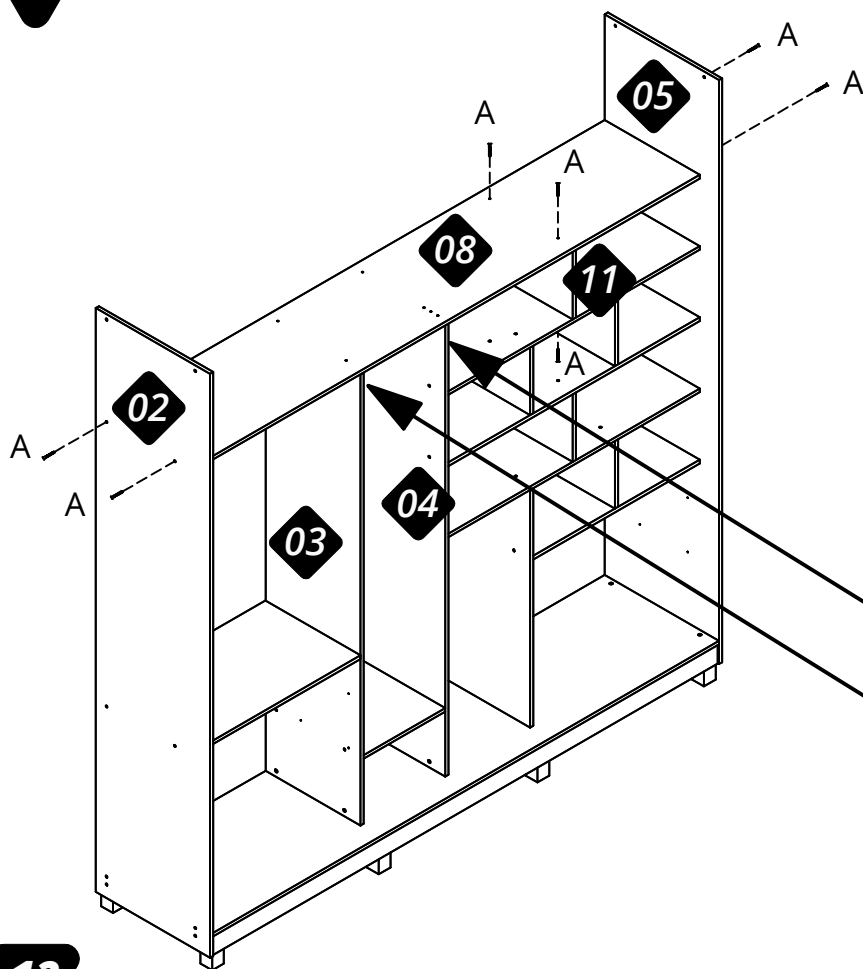

12

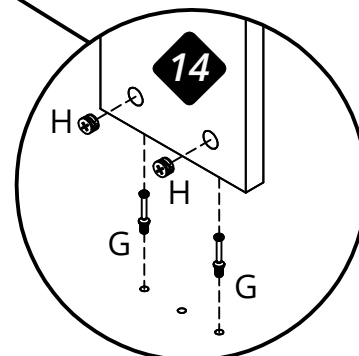
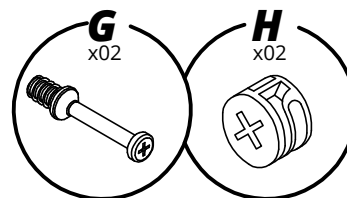
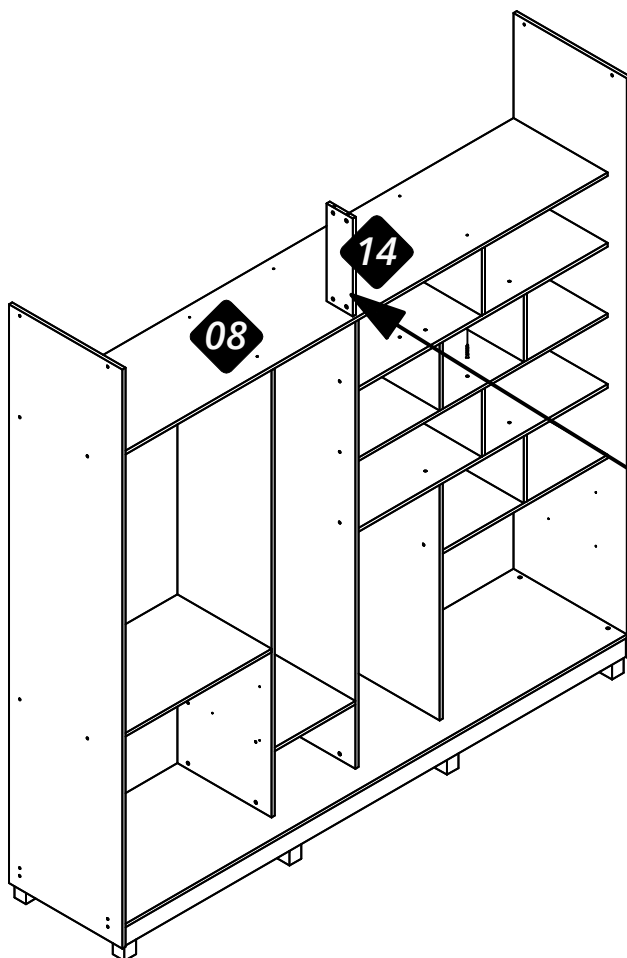

13

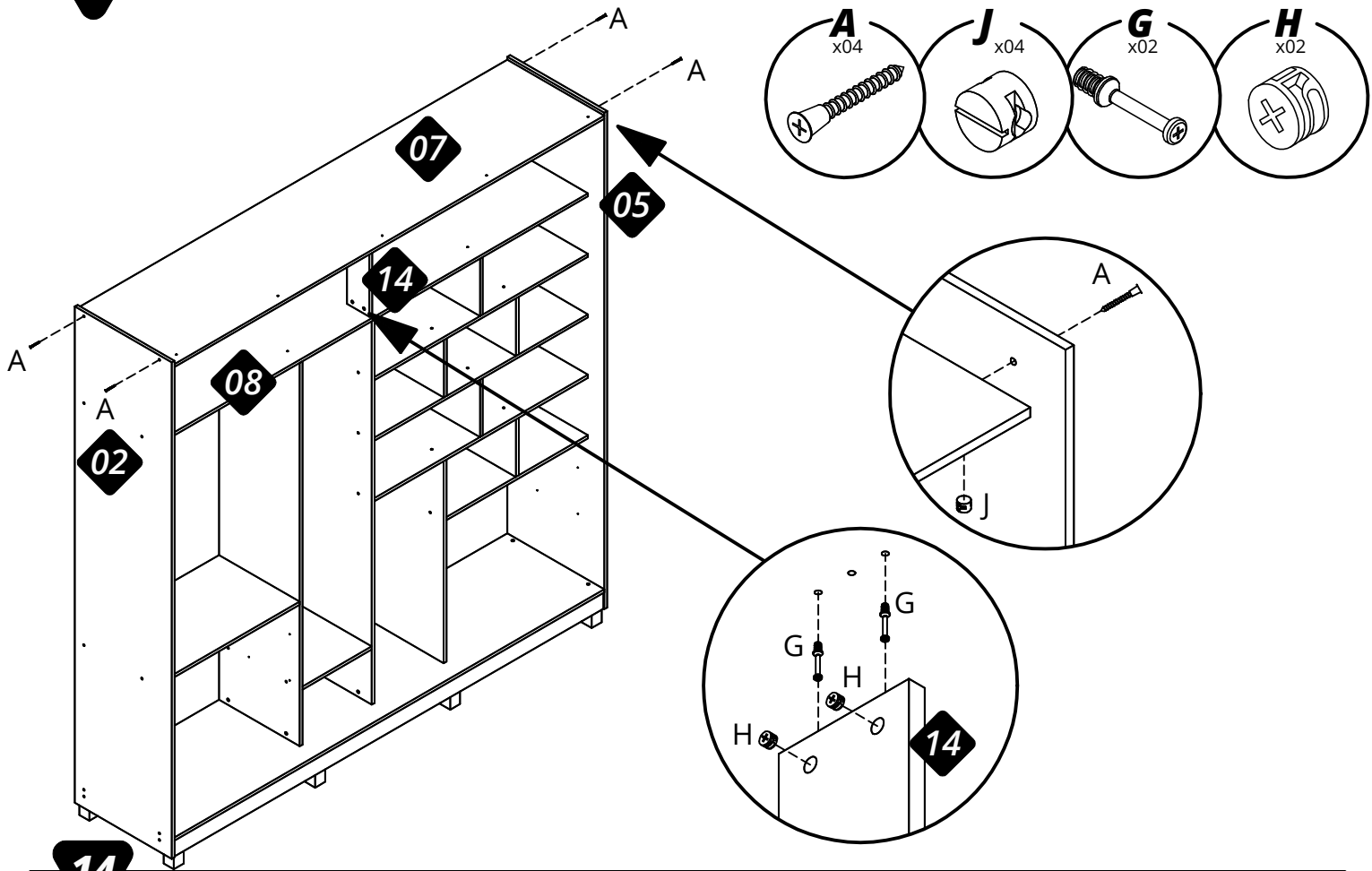

14

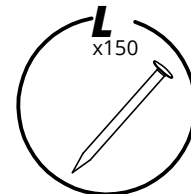
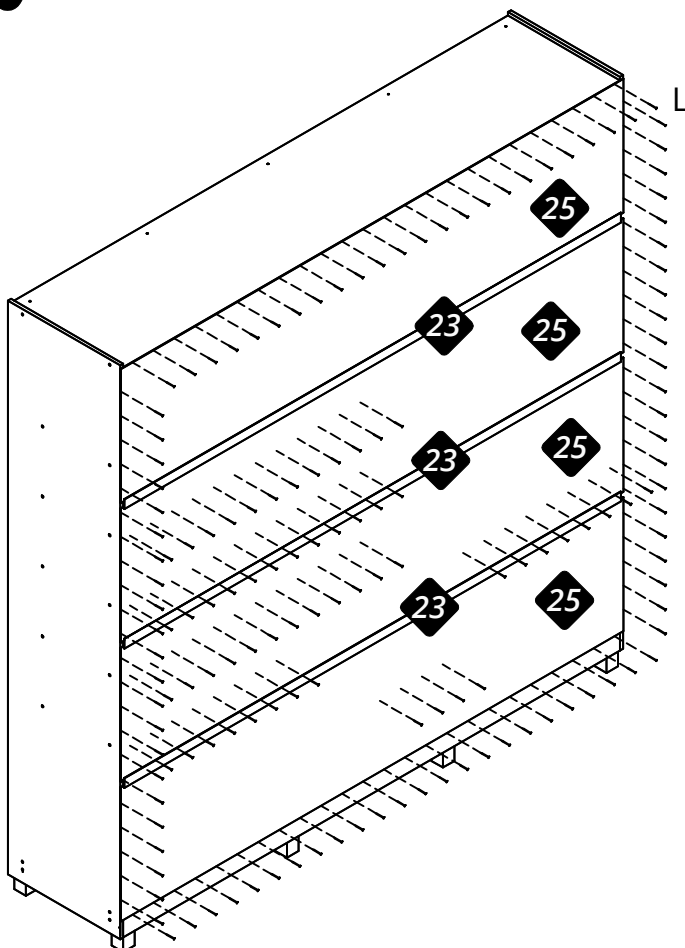

Atenção: Orientamos também,  
pregar os fundos nas prateleiras.

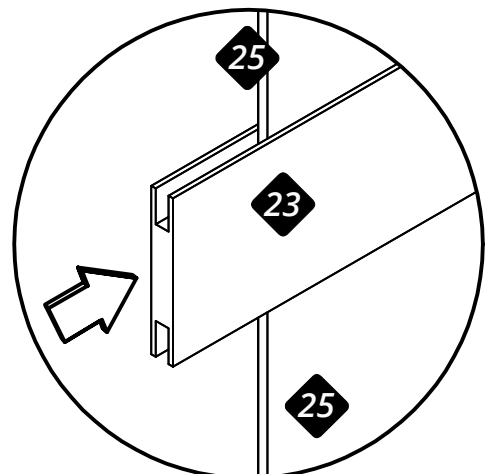

15

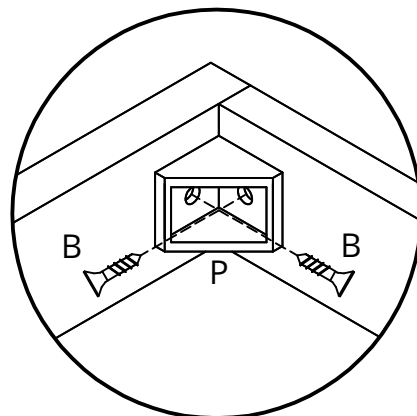
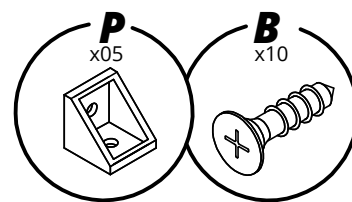
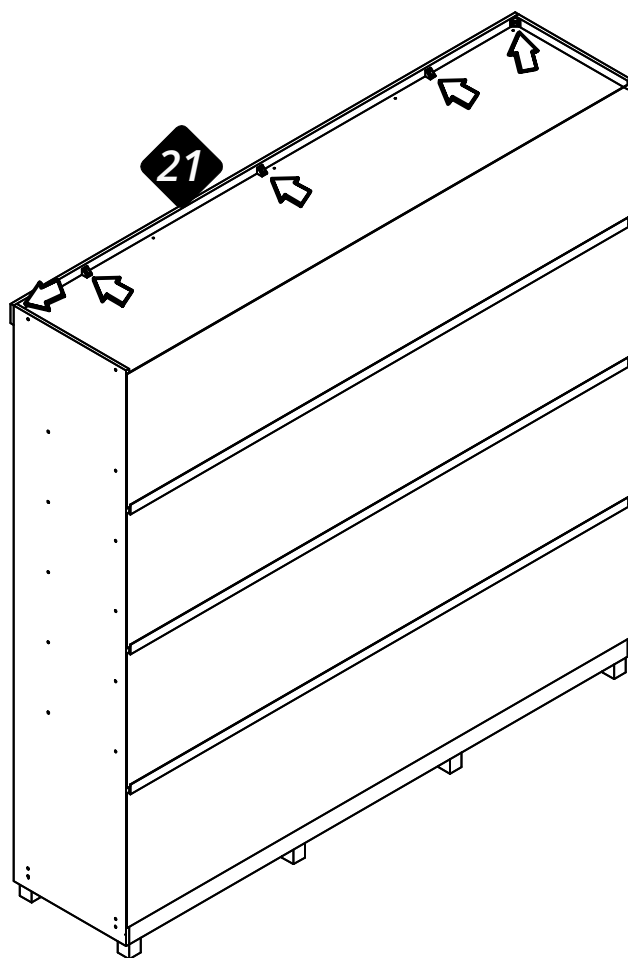

16

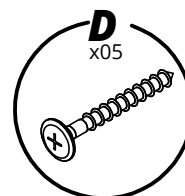
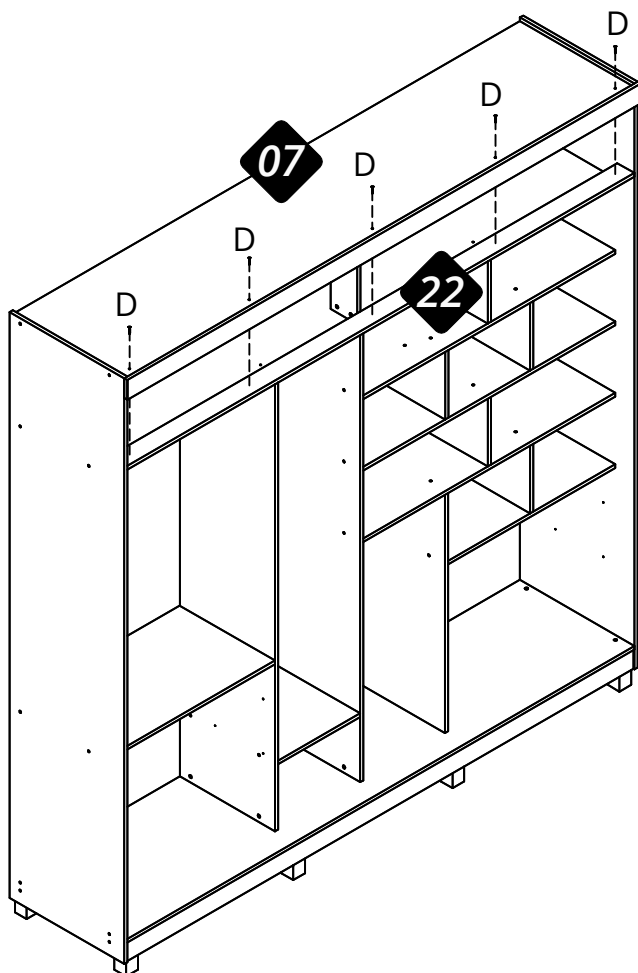

17

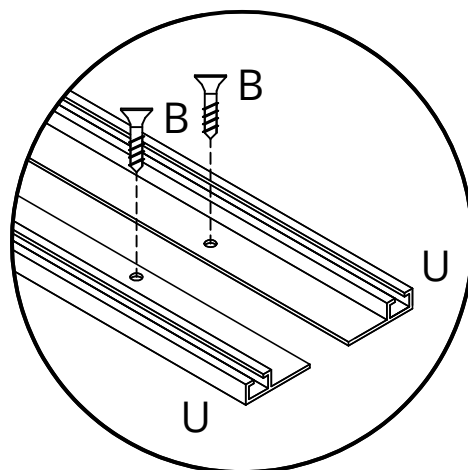
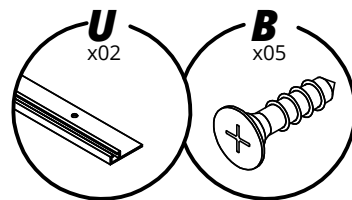
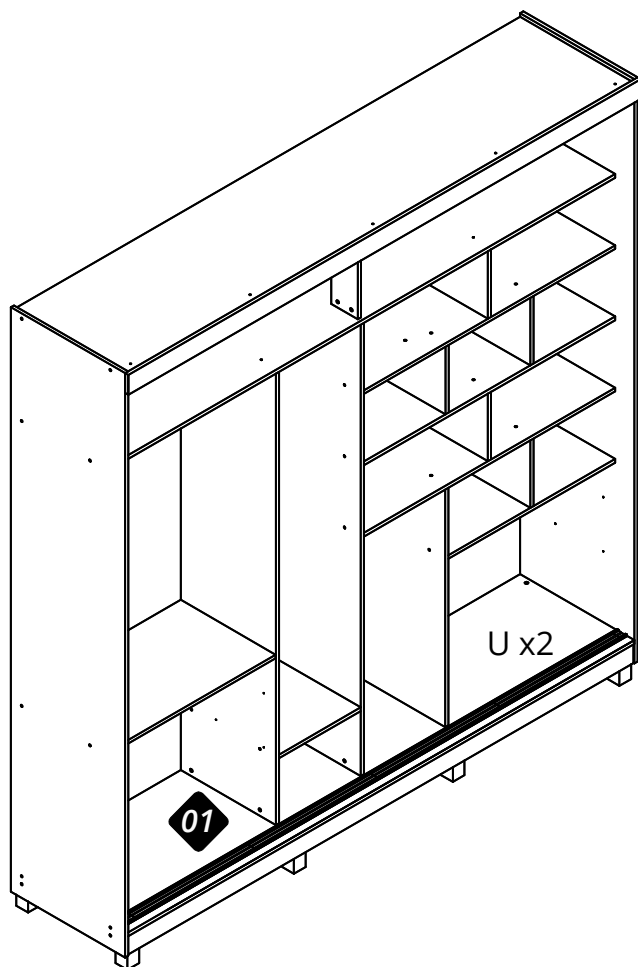

18

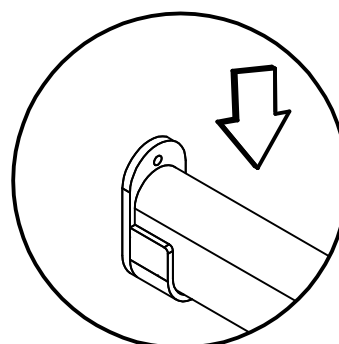
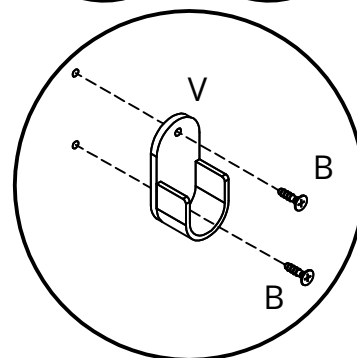
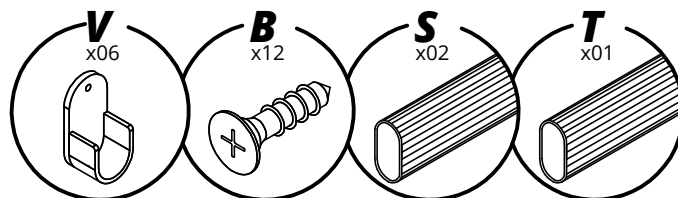
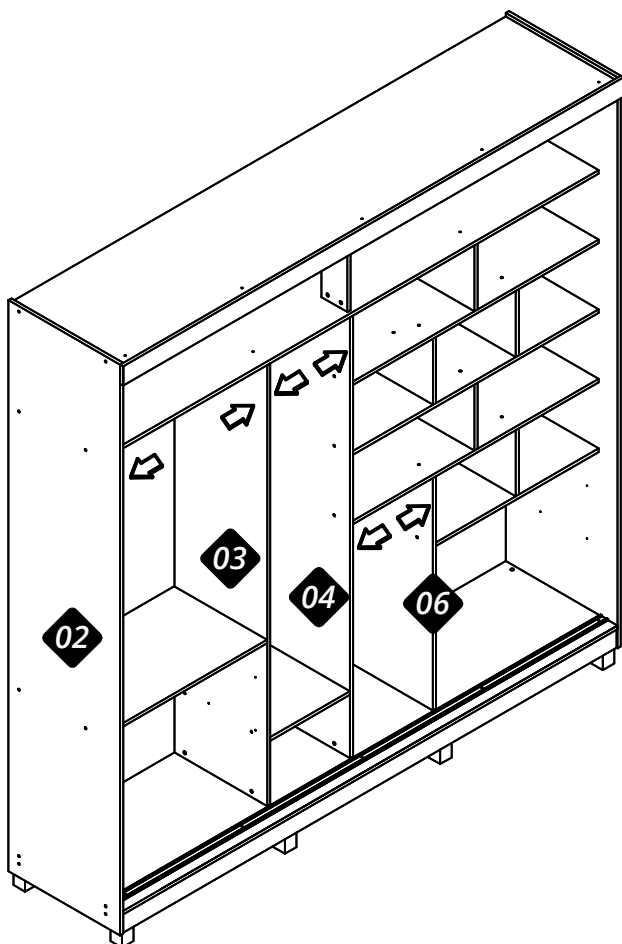

19

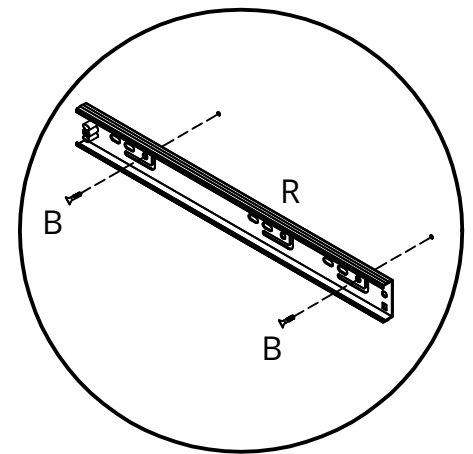
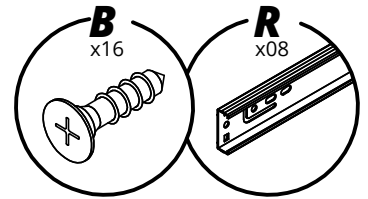
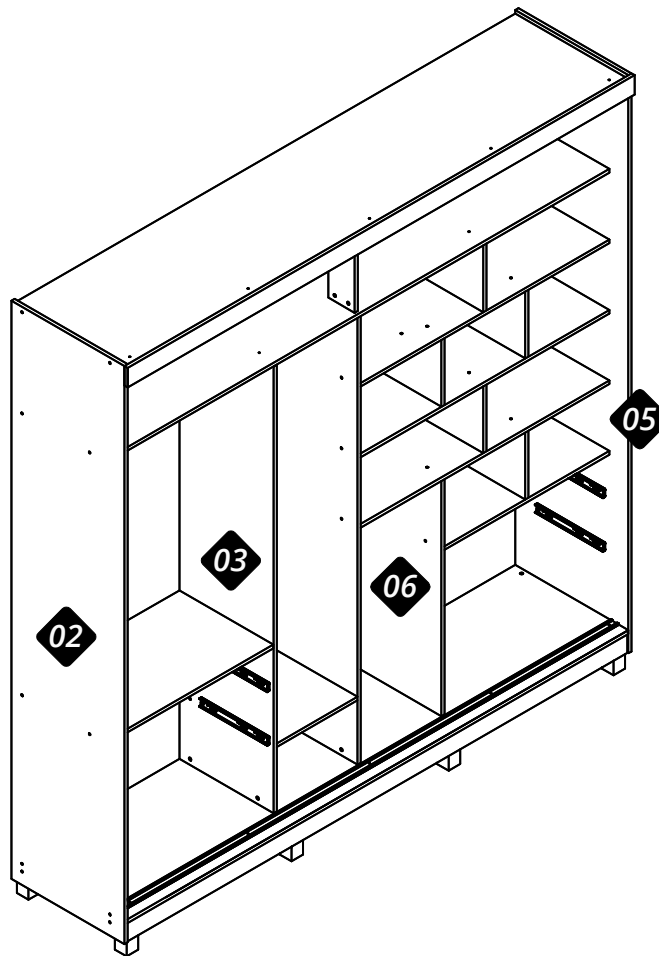

20

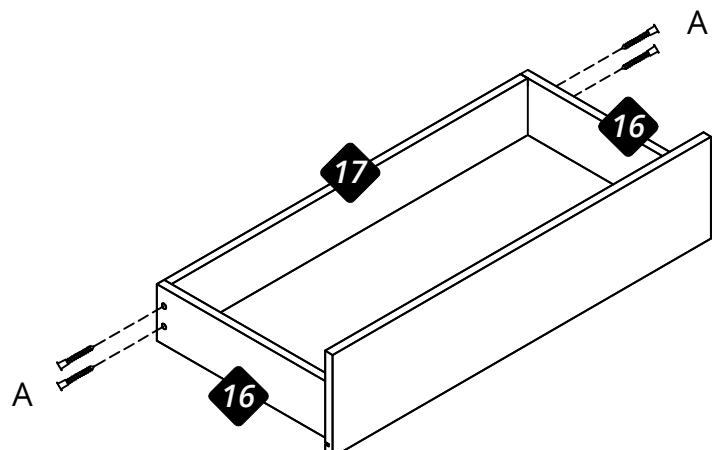
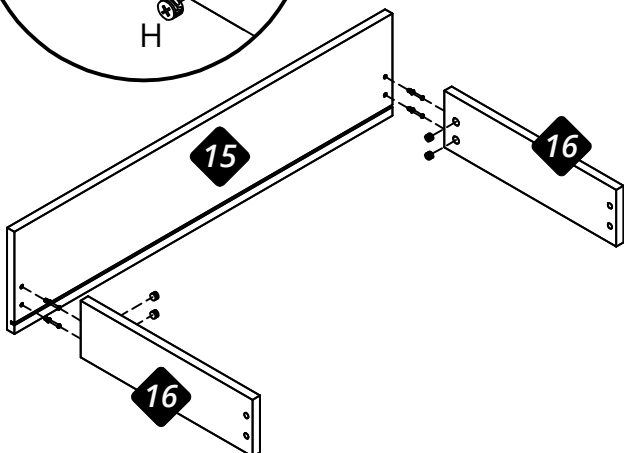
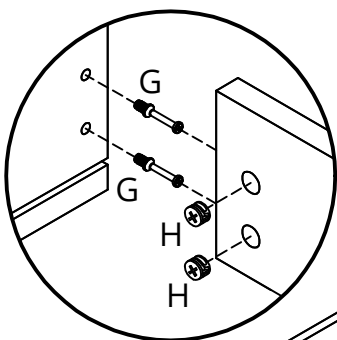
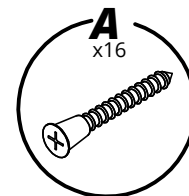
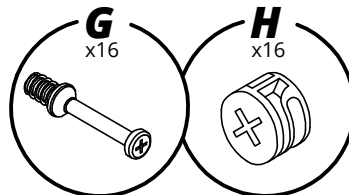

21

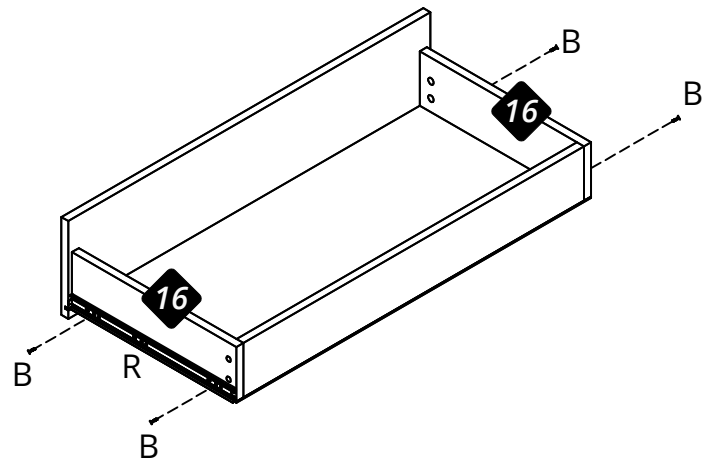
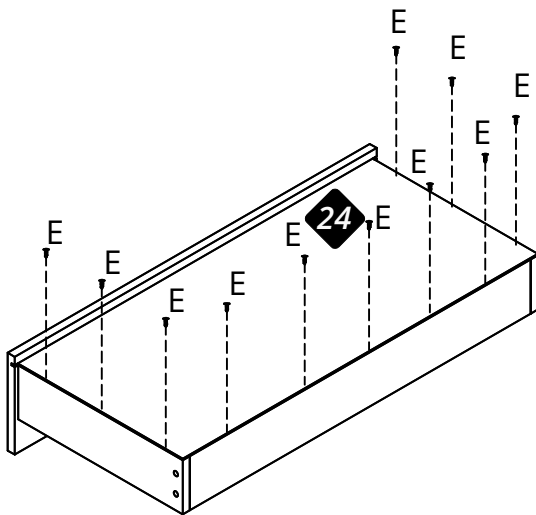
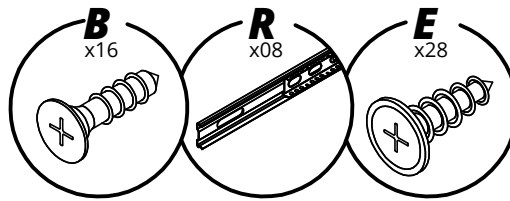

22

## MONTAGEM DA PORTA RIPADA

parte de cima

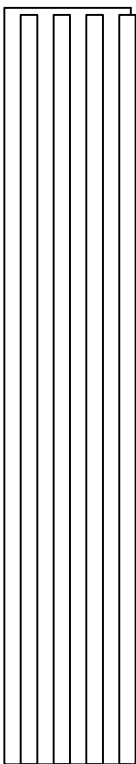

parte de baixo



ATENÇÃO: ao colocar as cavilhas, as ripas sempre devem ser alinhadas na parte de baixo da porta.

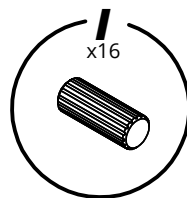

28



Finalize utilizando o parafuso D para fixar as ripas na porta.

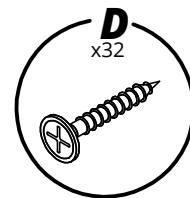

27

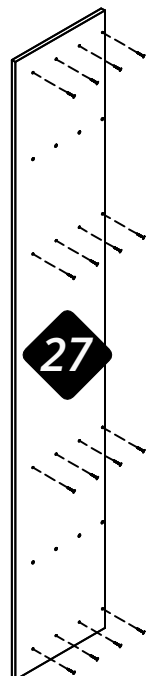

23

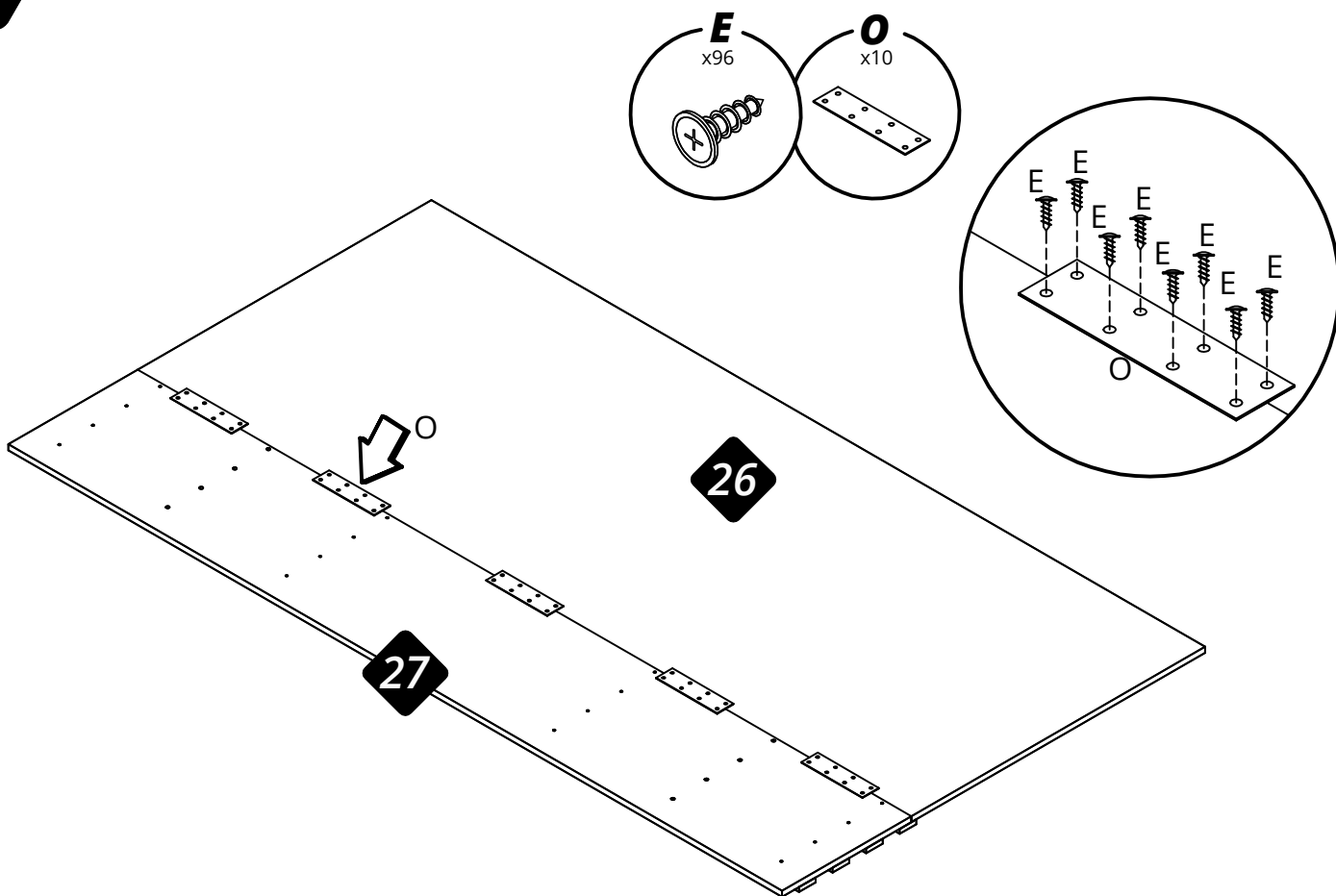

24

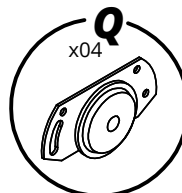
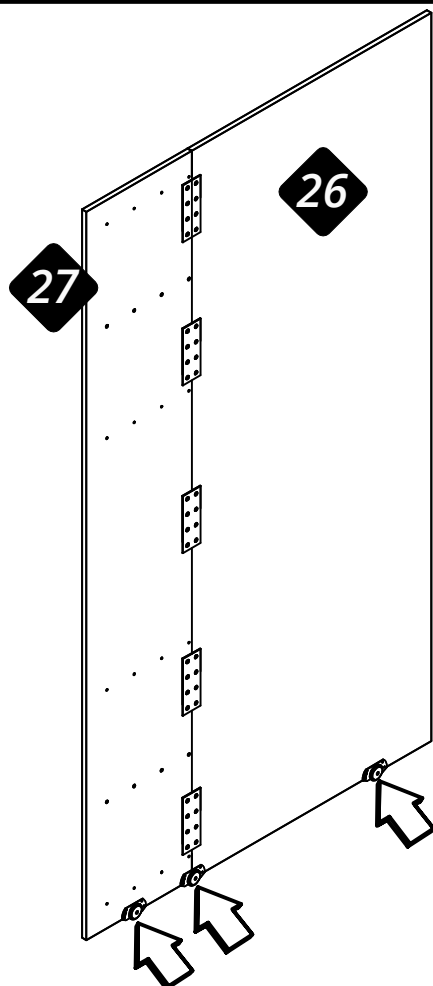

Atenção:  
Instalar 3 roldanas em cada porta conforme indicado.

