

HENN

Ind. e Com. de Móveis Henn
Mondai - SC - Brasil

+55 49 3674.3500

@moveishenn
www.henn.com.br

INSTRUÇÕES DE MONTAGEM

INSTRUCCIONES DE MONTAJE
ASSEMBLY INSTRUCTIONS

Roupeiro Atalaia 06 Portas | Armario Atalaia 06 Puertas | Wardrobe Atalaia 06 doors

- c D218-35 Duna/Cristal
- c D218-94 Rústico
- c D218-130 Castanho HP

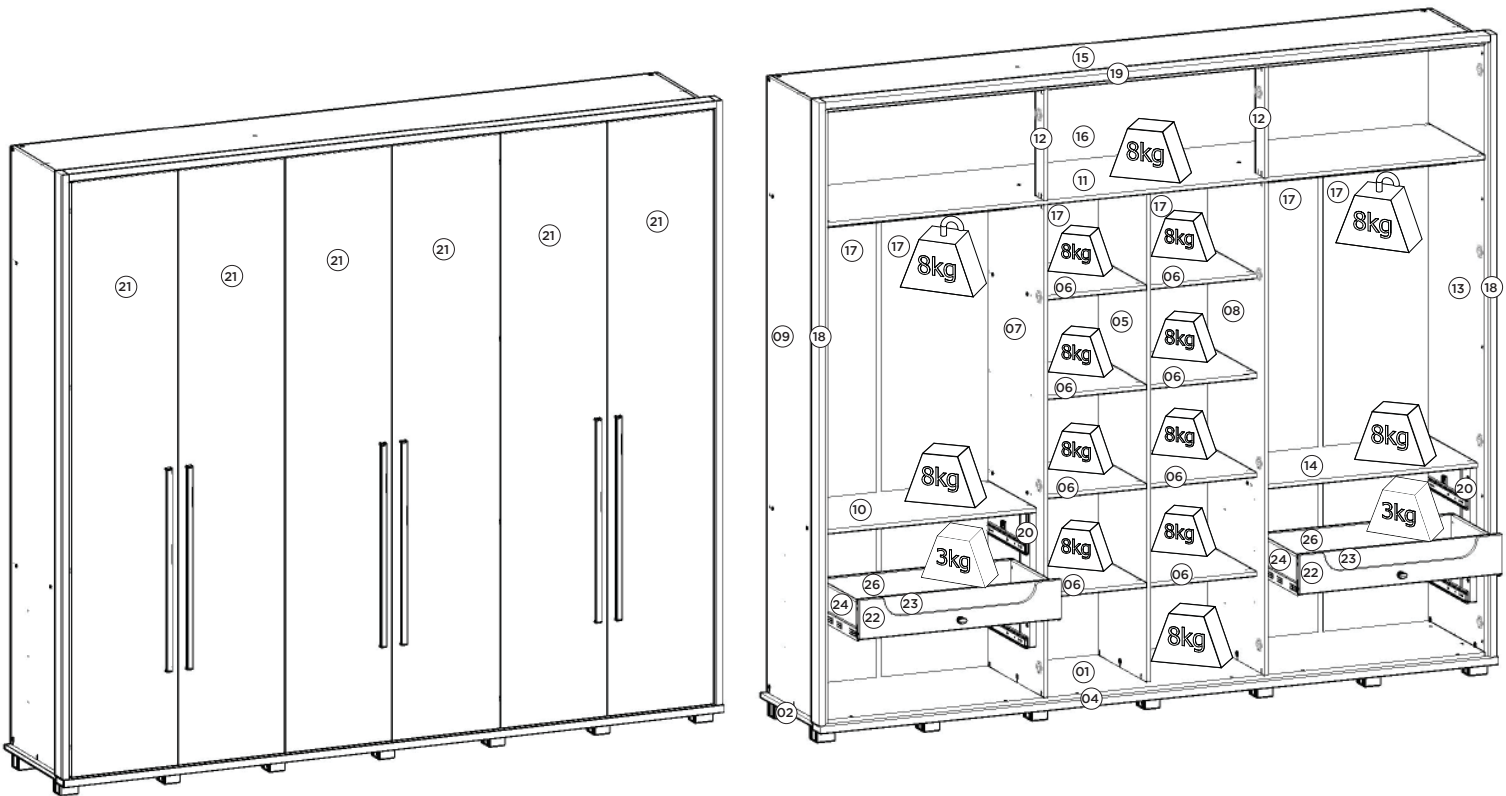

Pesos máximos recomendados com carga distribuída
Peso máximo recomendado con la carga distribuida
Recommended maximum weights with evenly distributed.

Requisitos para montagem
Requisitor para la montaje
Assembly Requirements

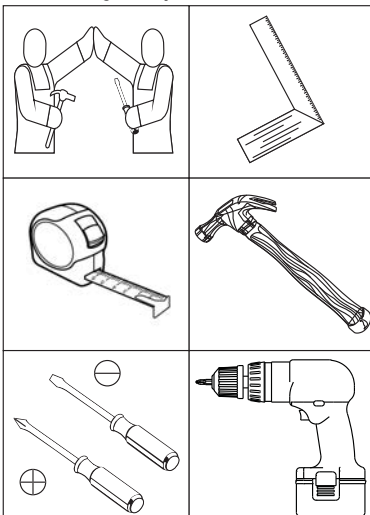

Imagens meramente ilustrativas
Imágenes meramente ilustrativas
Images for illustration only

AVISO

Para limpeza de seu móvel, use uma flanela seca ou umedecida, e não utilize produtos químicos que possam danificar seu produto.

SISTEMA DE MONTAGEM

O sistema de montagem dos produtos, funciona de acordo com a ordem crescente dos números indicados no desenho. Ex: 01, 02, 03, 04... até a conclusão da montagem.

ADVERTENCIA

Para limpieza de su móvil, use una flanela seca o húmeda, y no utilice productos químicos que puedan dañar su producto.

SISTEMA DE MONTAJE

El sistema de montaje de los productos funciona de acuerdo con el orden creciente de los números indicados en el dibujo. Ej.: 01, 02, 03, 04... hasta la conclusión del montaje.

NOTICE

To clean your furniture, use a dry or wet cloth, and do not use chemicals that may damage your product.

ASSEMBLY SYSTEM

The products' assembly system works according to the increasing order of the indicated numbers. For example: 01, 02, 03, 04 ... to the end of the assembly.

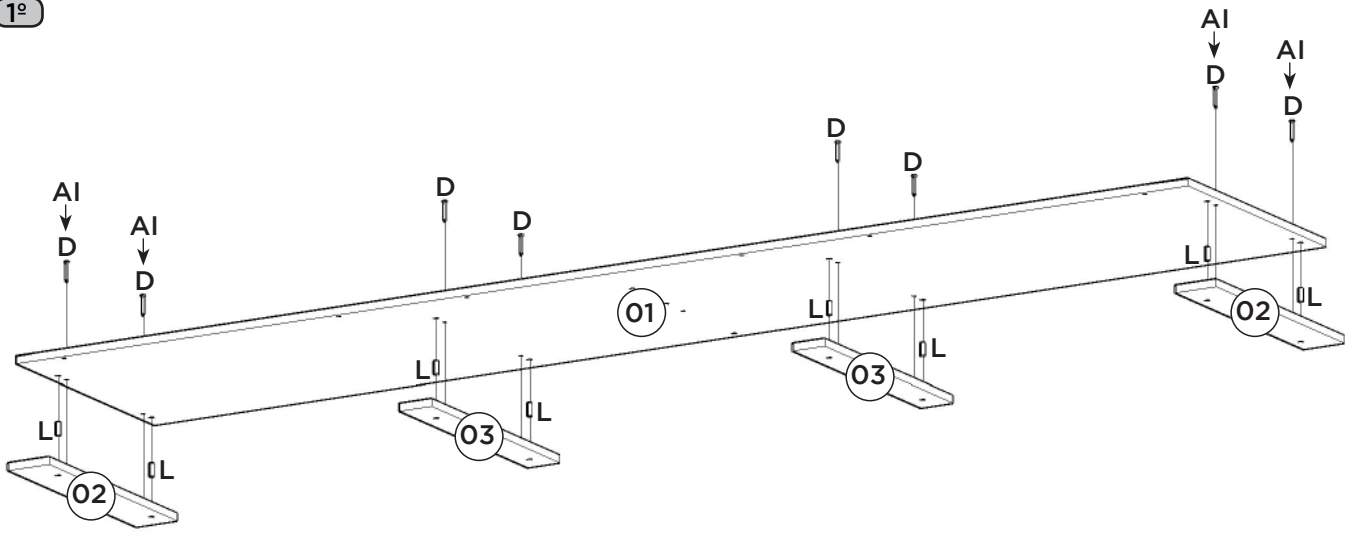

2º

Para a colocação da travessa frontal base (04) alinhar a mesma com as travessas laterais base (02).

Para la colocación del travesaño delantero base (04) para alinearlo con las vigas de base lateral (02).

For placement of the base front strut (04) to align the same with the base side beams (02).

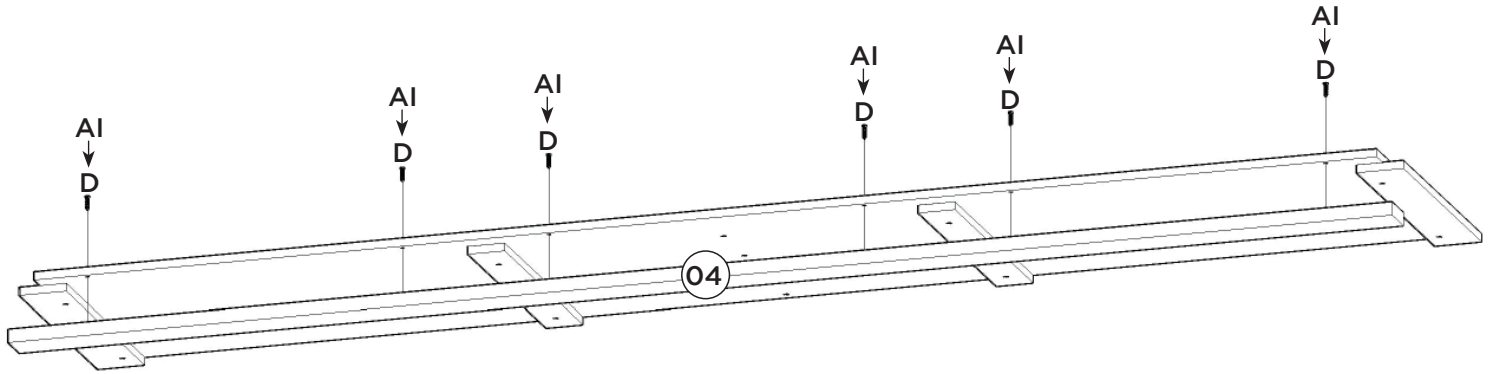

3º

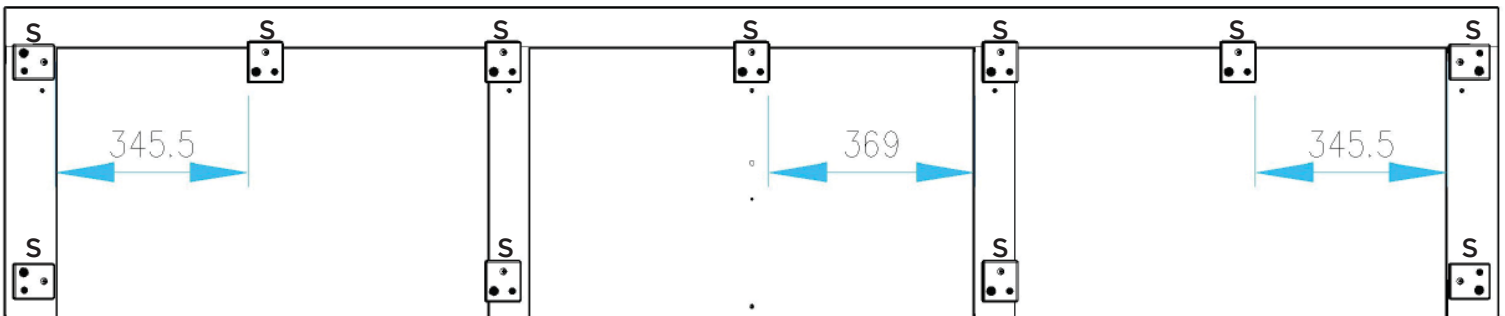
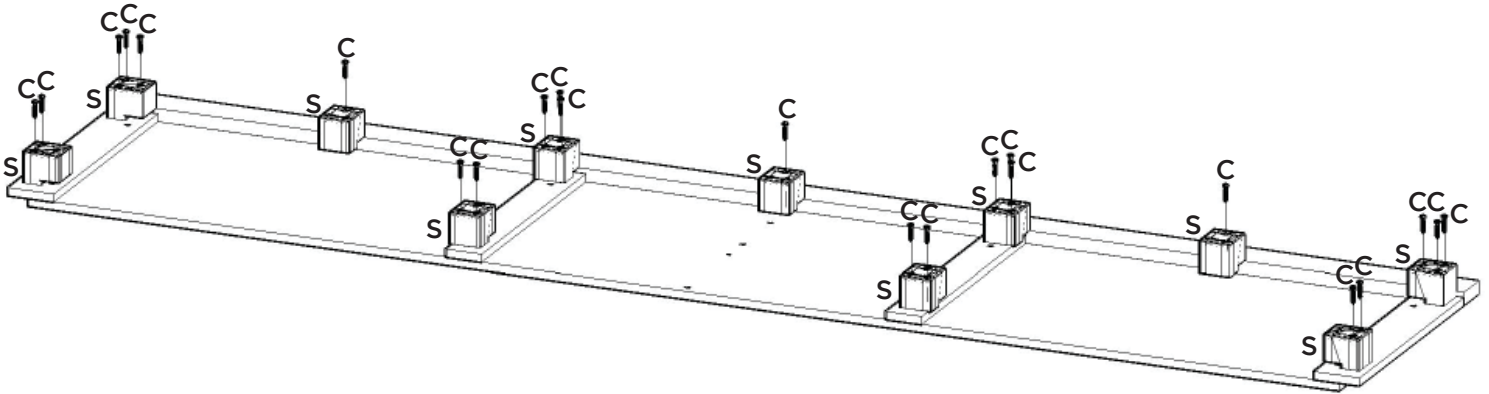

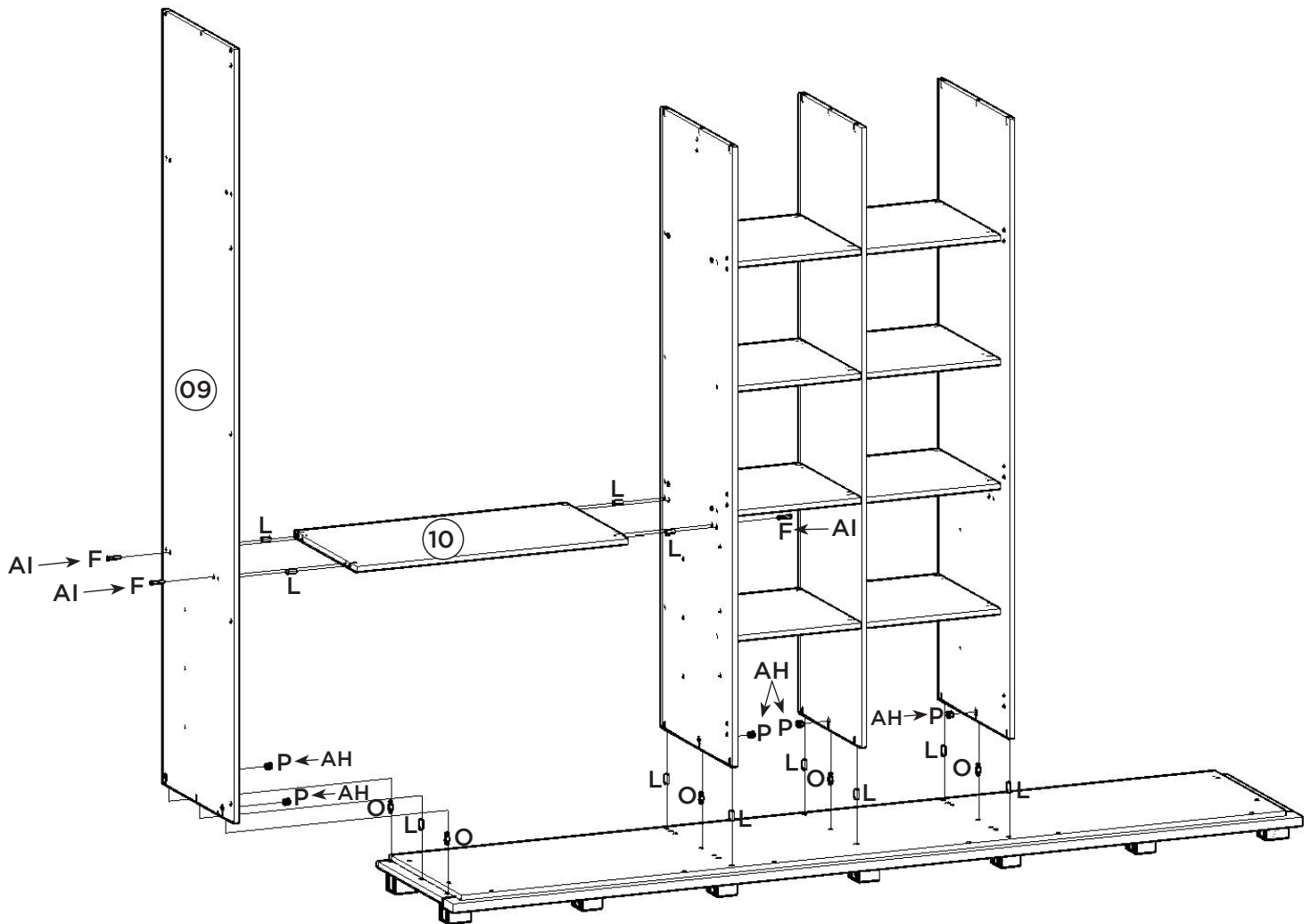
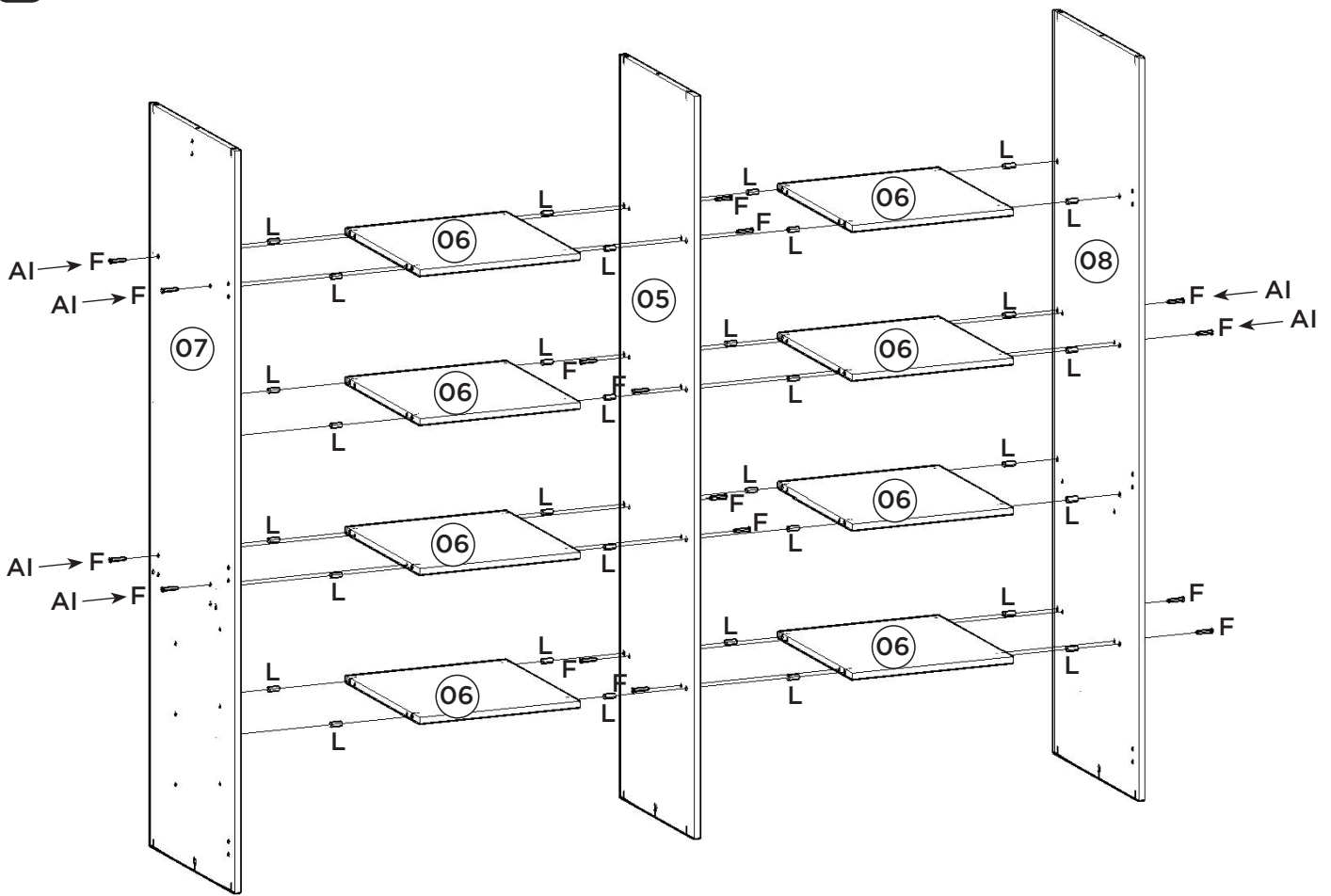

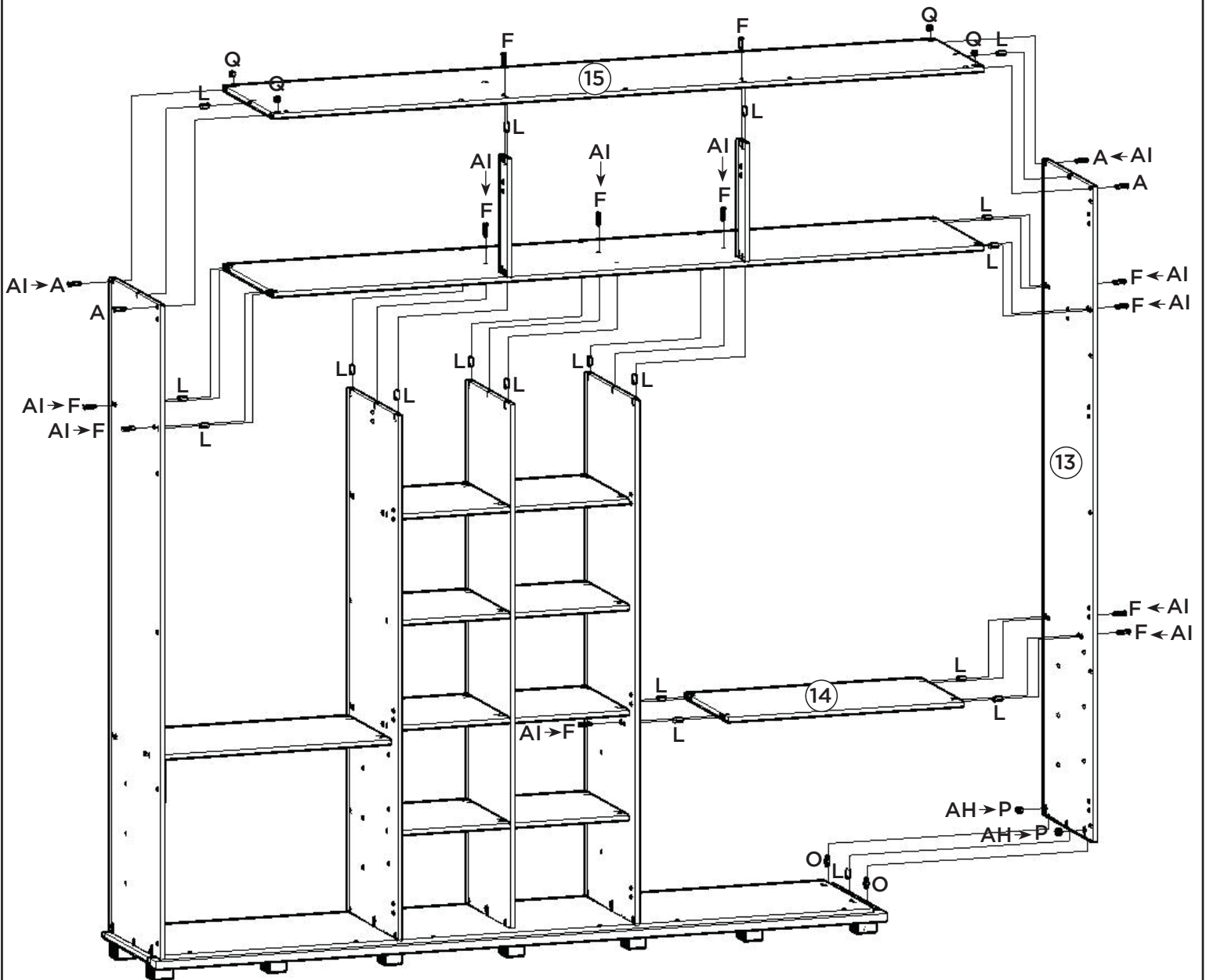
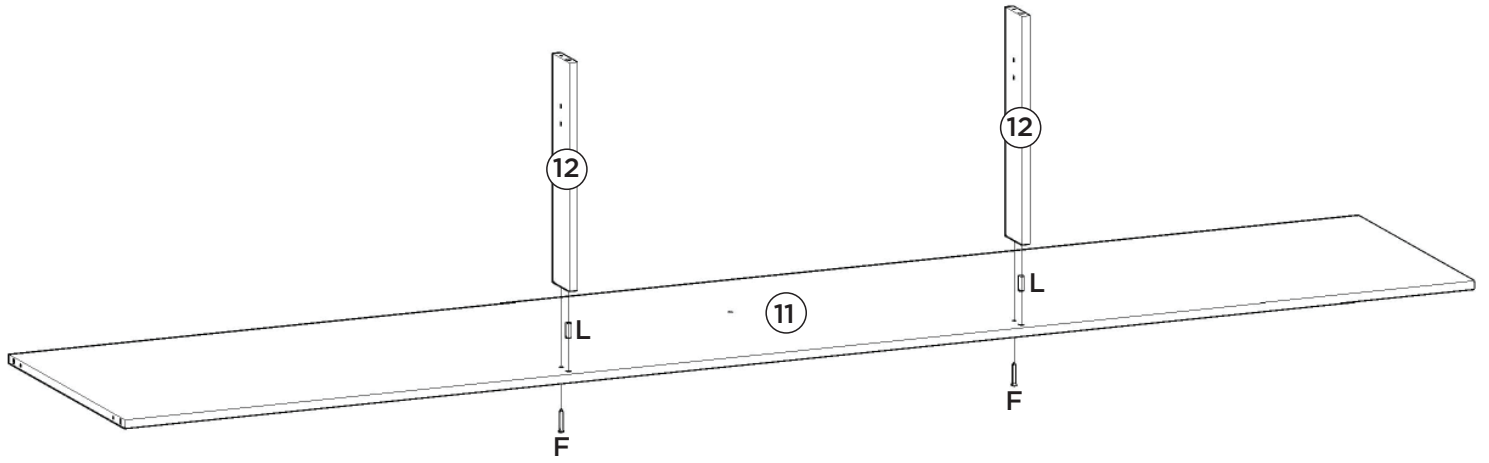

8°

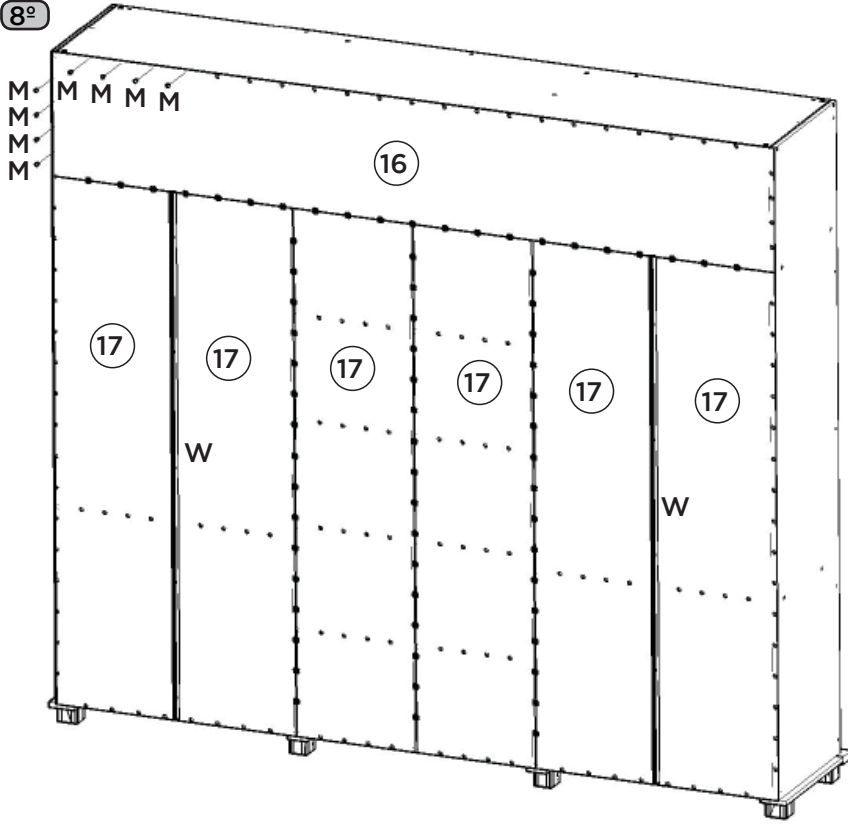

Colocar os pregos (M) a uma distância de 100mm de um para outro.

Coloque los clavos (M) a una distancia de 100 mm uno de otro.

Place the nails (M) at a distance of 100mm from one another.

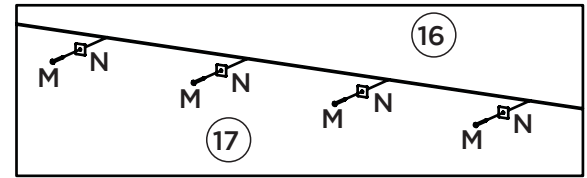
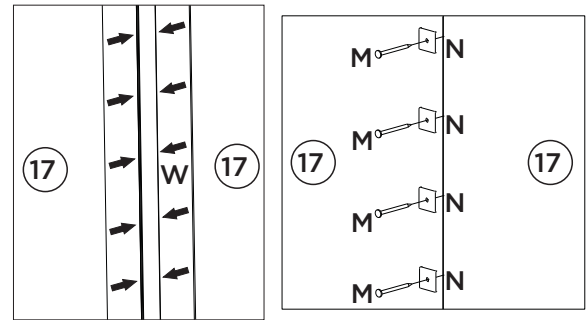

9°

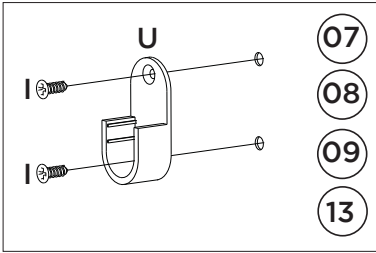

- (07)
- (08)
- (09)
- (13)

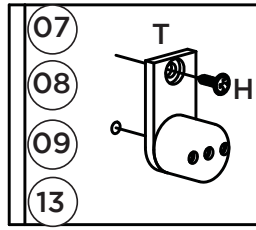

- (07)
- (08)
- (09)
- (13)

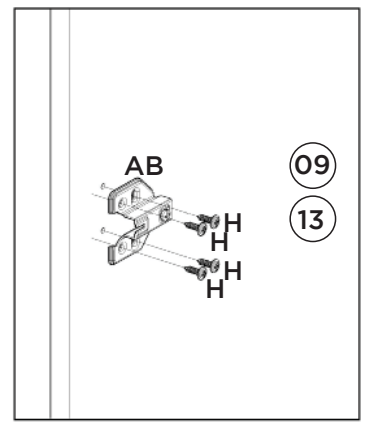
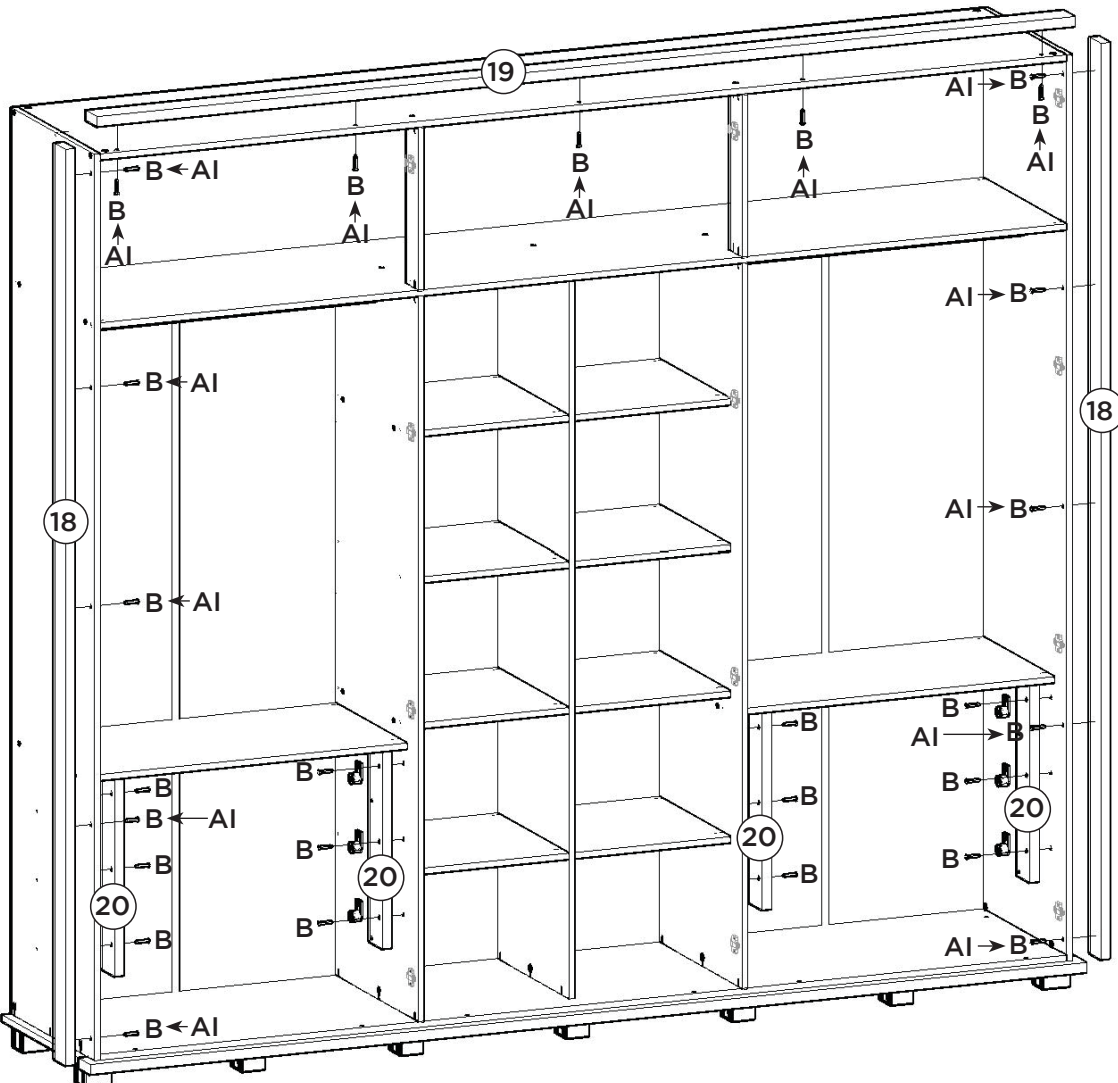
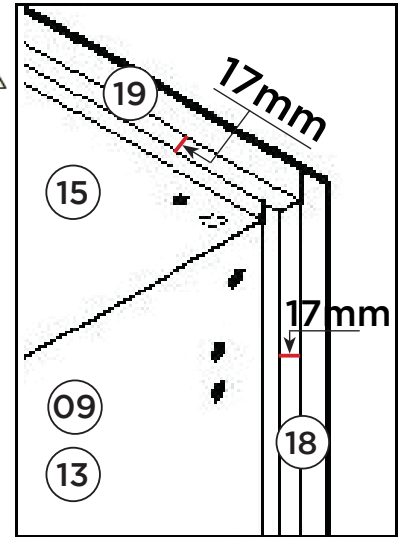

- (09)
- (13)

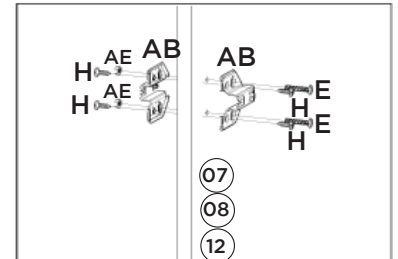

- (07)
- (08)
- (12)

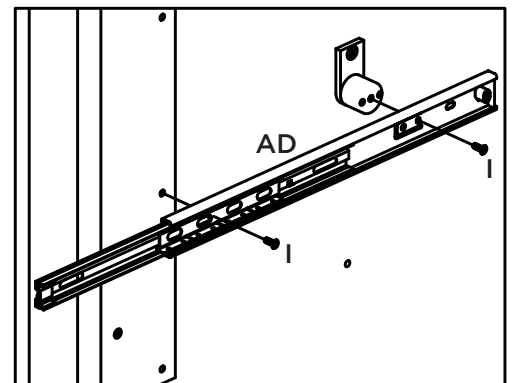
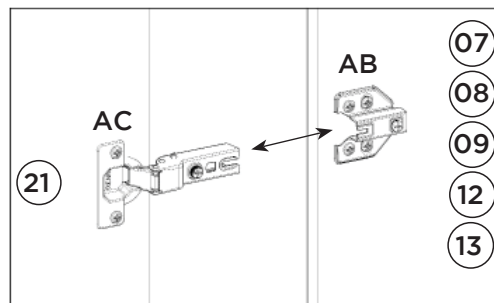
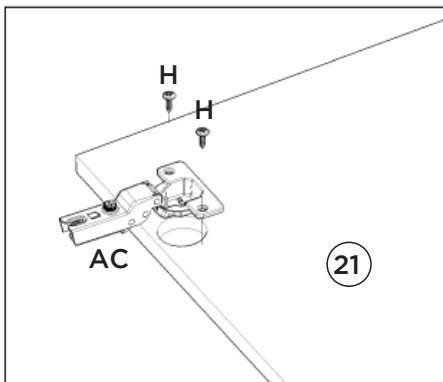
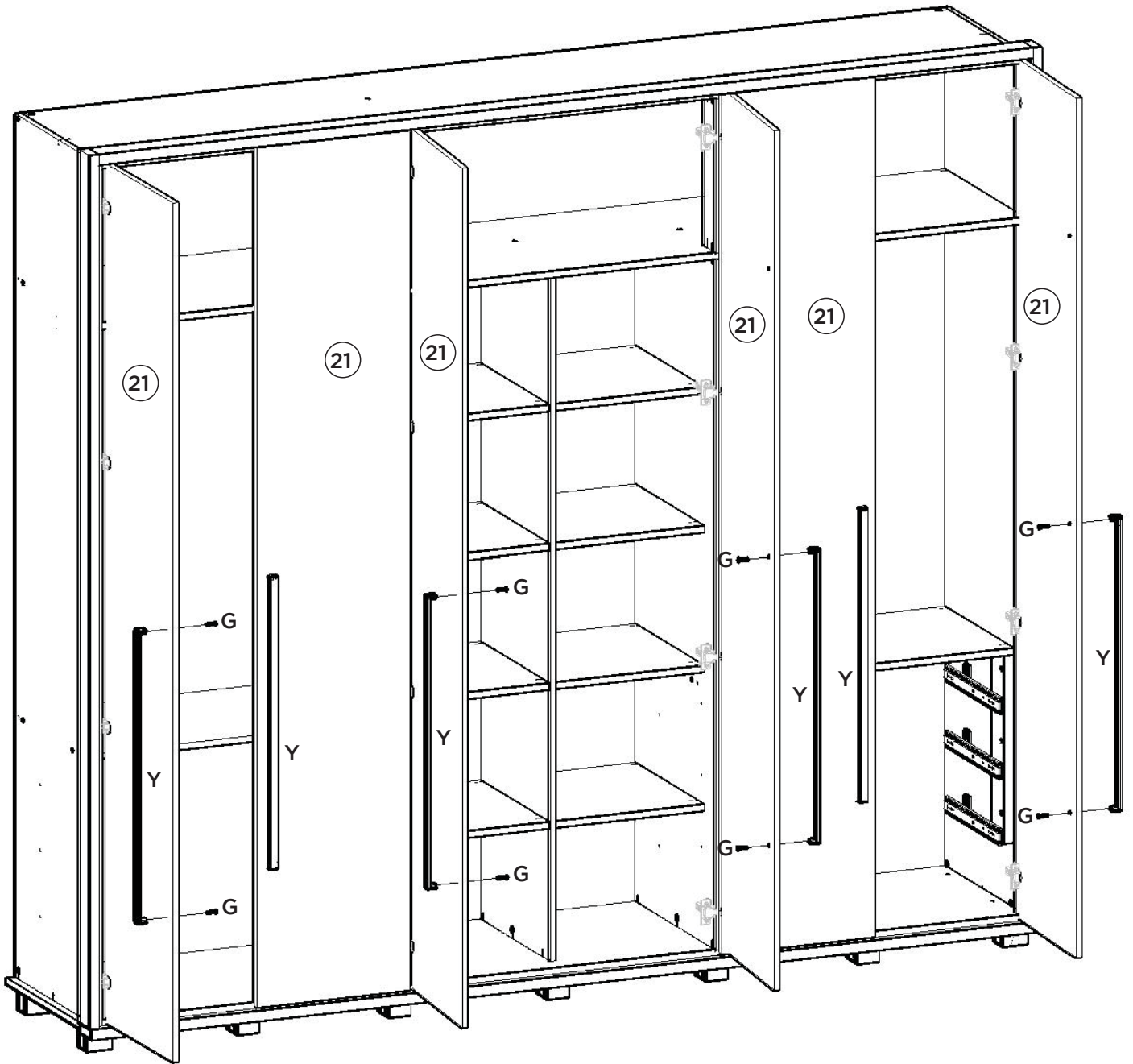

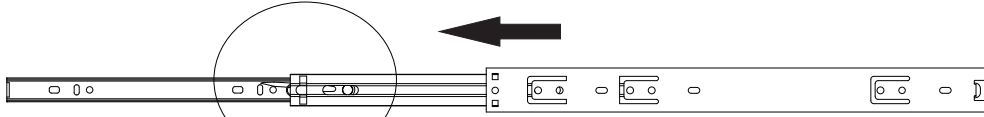

Para a desmontagem da corredeira siga a instrução ao lado.

Para el desmontaje seguimiento de diapositivas la instrucción siguiente a.

For the dismount of the sliding onem follows the instruction aside.

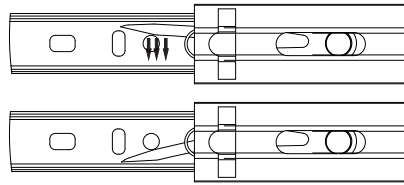



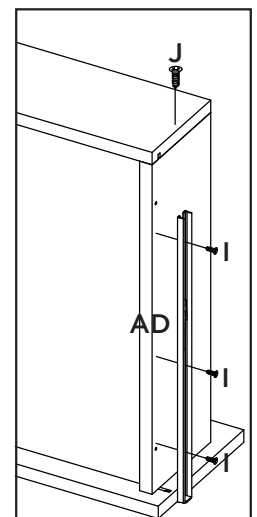
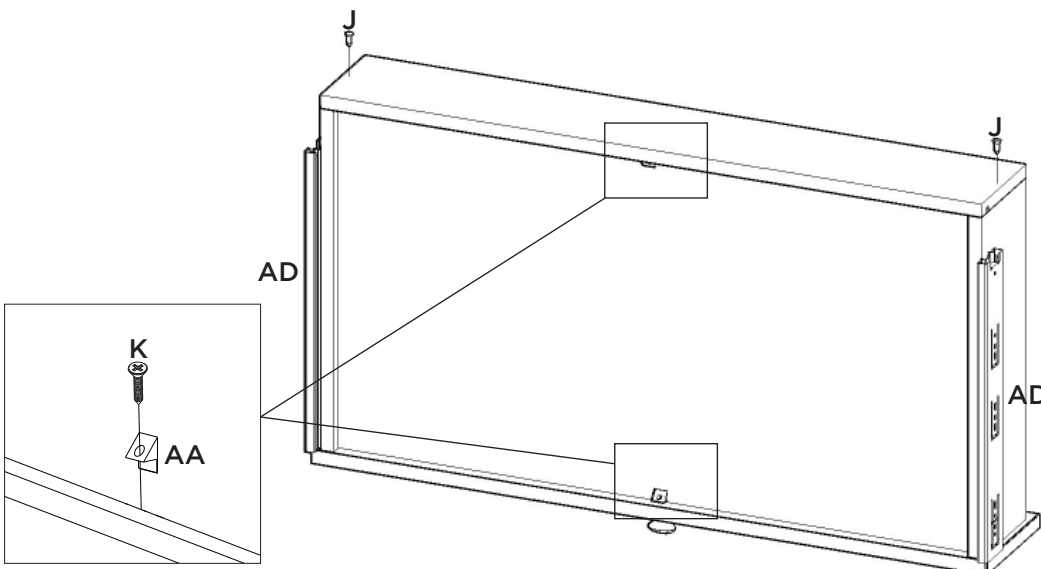
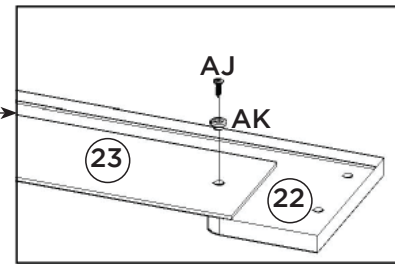
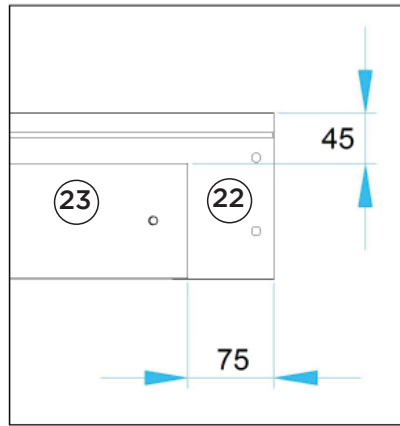
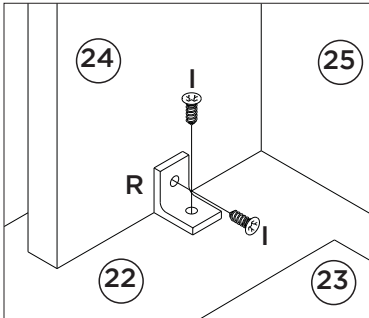
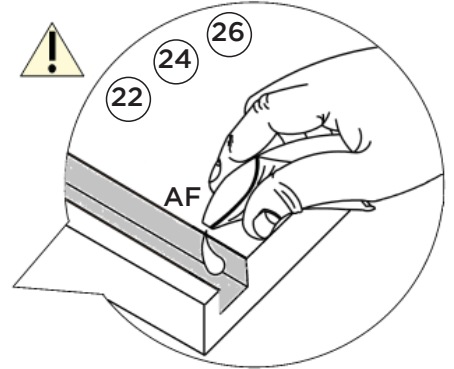
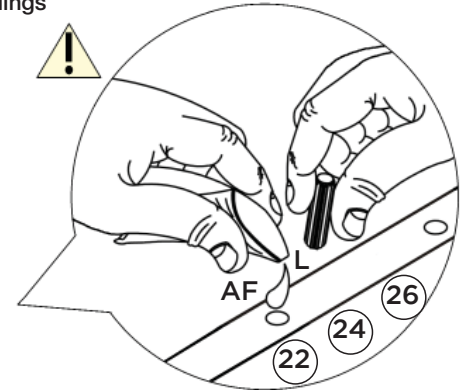
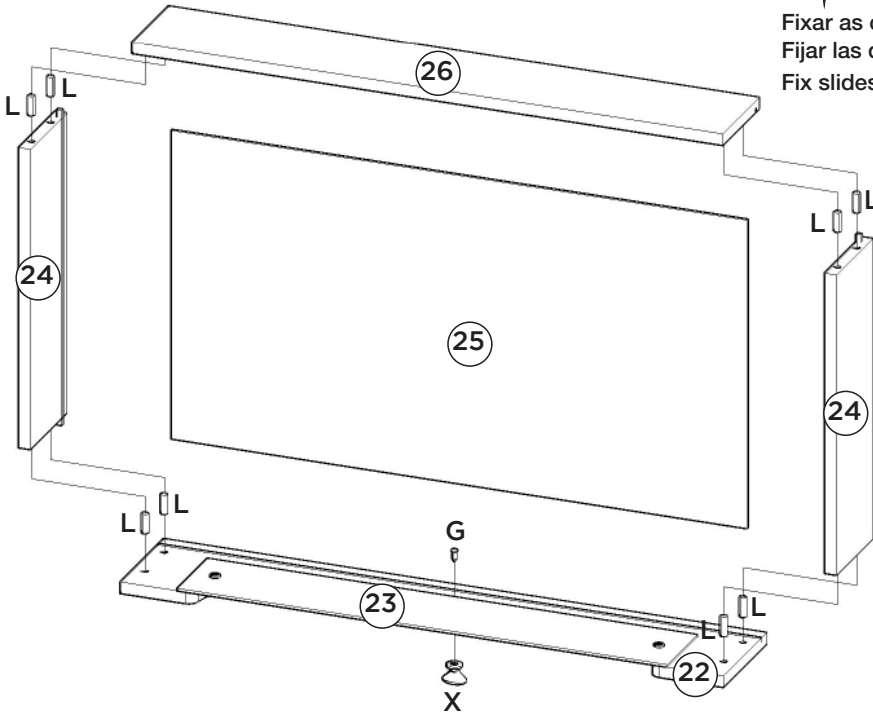







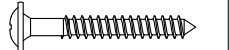
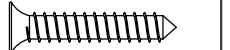
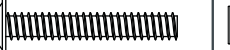

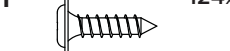
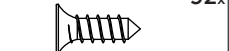

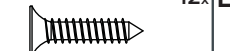

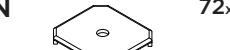
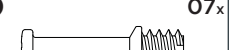

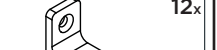
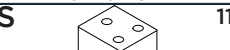

Fixar as corredeiras nessas furações
Fijar las diapositivas de estos agujeros
Fix slides in these drillings

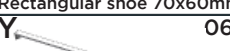
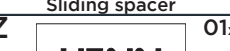
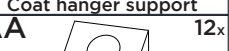

Item	Caixa Caja Box	Qty Ctd Qty	Descrição Descripción Description	Medidas (mm) Dimensions (mm) Size (measurements) (mm)
01	2/6	01	Base Base Base	2589x520x15
02	2/6	02	Travessa lateral base Carril lateral base Base side crossbar	482x90x15
03	2/6	02	Travessa central base Carril central base Central base rail	482x70x15
04	2/6	01	Travessa frontal base Carril delantera de la base Base front crossbar	2670x70x25
05	3/6	01	Divisão Central División Central Central Division	1841x452x15
06	4/6	08	Prateleira central Estante central Central shelf	450x419x15
07	3/6	01	Divisão esquerda División de la izquierda Left Division	1841x520x15
08	3/6	01	Divisão direita División derecha Right division	1841x520x15
09	1/6	01	Lateral esquerda Lateral izquierda Left side	2300x520x15
10=14	4/6	01	Tampo das Gavetas Tapa de los cajones Drawer Top	853x450x15
11	1/6	01	Chão do Maleiro Piso del Armario de Equipaje Floor of the Maleiro	2589x520x15
12	3/6	02	Ripa do Maleiro Listón del Armario de Equipaje Clapboard luggage locker	414x73x15
13	1/6	01	Lateral direita Lateral derecha Right side	2300x520x15
14=10	4/6	01	Tampo das Gavetas Tapa de los cajones Drawer Top	853x450x15
15	2/6	01	Tampo Tapa Top	2589x520x15
16	1/6	01	Fundo Superior Fondo Superior Superior background	2613x436x3
17	6/6	06	Fundo Fondo Bottom	1863x433x3
18	2/6	02	Moldura Lateral Marco lateral Lateral Frame	2325x68x25
19	2/6	01	Moldura Superior Marco superior Upper Frame	2619x68x25
20	2/6	04	Ripa lateral Ripa lateral Ripa side	502x80x25
21	5/6 e 6/6	06	Porta Puerta Door	2289x430x15
22	4/6	06	Frete de gaveta Frente de cajón Front of drawer	795x145x15
23	2/6	06	Vidro incolor com furo Vidrio incoloro con agujero Colorless glass with hole	645x100x3
24	3/6	12	Lado de gaveta Lado del cajón Side of drawer	400x122x15
25	6/6	06	Fundo de gaveta Fondo del cajón Fondo de cajón	759x411x3
26	4/6	06	Ripa de trás Malla detrás Rear lath	778x122x15

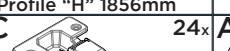
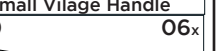
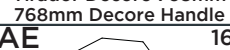
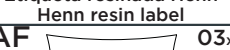
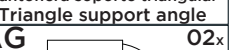
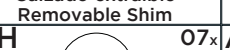
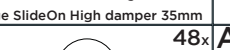
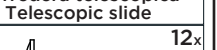
Ferragens | Herrajes | Hardware

A  Parafuso 4,5x50mm CHT. Tornillo 4,5x50mm CHT. Screw 4,5x50mm CHT.	B  Parafuso 4,0x35mm CHT. Tornillo 4,0x35mm CHT. Screw 4,0x35mm CHT.	C  Parafuso 4,0x30mm FLA. Tornillo 4,0x30mm FLA. Screw 4,0x30mm FLA.	D  Parafuso 4,0x25mm CHT. Tornillo 4,0x25mm CHT. Screw 4,0x25mm CHT.	E  Parafuso 4,0x25mm FLA. Tornillo 4,0x25mm FLA. Screw 4,0x25mm FLA.	F  Parafuso 3,5x40mm CHT. Tornillo 3,5x40mm CHT. Screw 3,5x40mm CHT.
G  Parafuso 3,5x25mm FLA. Tornillo 3,5x25mm FLA. Screw 3,5x25mm FLA.	H  Parafuso 3,5x14mm FLA. Tornillo 3,5x14mm FLA. Screw 3,5x14mm FLA.	I  Parafuso 3,5x12mm CHT. Tornillo 3,5x12mm CHT. Screw 3,5x12mm CHT.	J  Parafuso 3,0x30mm CHT. Tornillo 3,0x30mm CHT. Screw 3,0x30mm CHT.	K  Parafuso 3,0x16mm CHT. Tornillo 3,0x16mm CHT. Screw 3,0x16mm CHT.	L  Cavilha 8x25mm Cinta 8x25mm Dowel 8x25mm
M  Prego 10x10mm Clavo 10x10mm Nail 10x10mm	N  Fixador de fundos Fijador de fondos Bottom fixer	O  Parafuso minifix Tornillo minifix Minifix bolt	P  Tambor minifix Tambor minifix Minifix drum	Q  Porca cilíndrica Tuerca cilíndrica Cylindrical nut	R  Cantoneira plástica Cantoneira plástica Plastic angle brackets
S  Sapata retangular 70x60mm Zapata rectangular 70x60mm Rectangular shoe 70x60mm	T  Distanciador de corrediça Distanciador de deslizamiento Sliding spacer	U  Suporte cabideiro Soporte de percha Coat hanger support	V  Cabideiro Alum. 845mm Alu 845mm percha Alu coat hanger 845mm	W  Perfil "H" 1856mm Perfil "H" 1856mm Profile "H" 1856mm	X  Puxador Vilage pequeno Tirador Vilage pequeno Small Vilage Handle
Y  Puxador Decore 768mm Tirador Decore 768mm 768mm Decore Handle	Z  Etiqueta resinada Henn Etiqueta resinada Henn Henn resin label	AA  Cantoneira suporte triangular Cantoneira soporte triangular Triangle support angle	AB  Calço Removível Calzado extraíble Removable Shim	AC  Dobradilha SlideOn Alta Amortecedor 35mm Bisagra SlideOn Alta Amortiguador 35mm Hinge SlideOn High damper 35mm	AD  Corrediça telescópica Corredera telescópica Telescopic slide
AE  Porca Sextavada Tuerca Hexagonal Hexagon Nut	AF  Sachê de cola Bolsa de pegamento Glue bag	AG  Giz de correção Tiza de corrección Chalk of correction	AH  Adesivo tapa parafuso 17mm Adhesivo tapón de tornillo 17mm Bolt cover adhesive 17mm	AI  Adesivo tapa parafuso 10mm Adhesivo tapón de tornillo 10mm Bolt cover adhesive 10mm	AJ  Parafuso 3,5x14mm FLA. Tornillo 3,5x14mm FLA. Screw 3,5x14mm FLA.
AK  Buchta fixador de espelho Buje de sujeción del espejo Mirror fixing bush					