

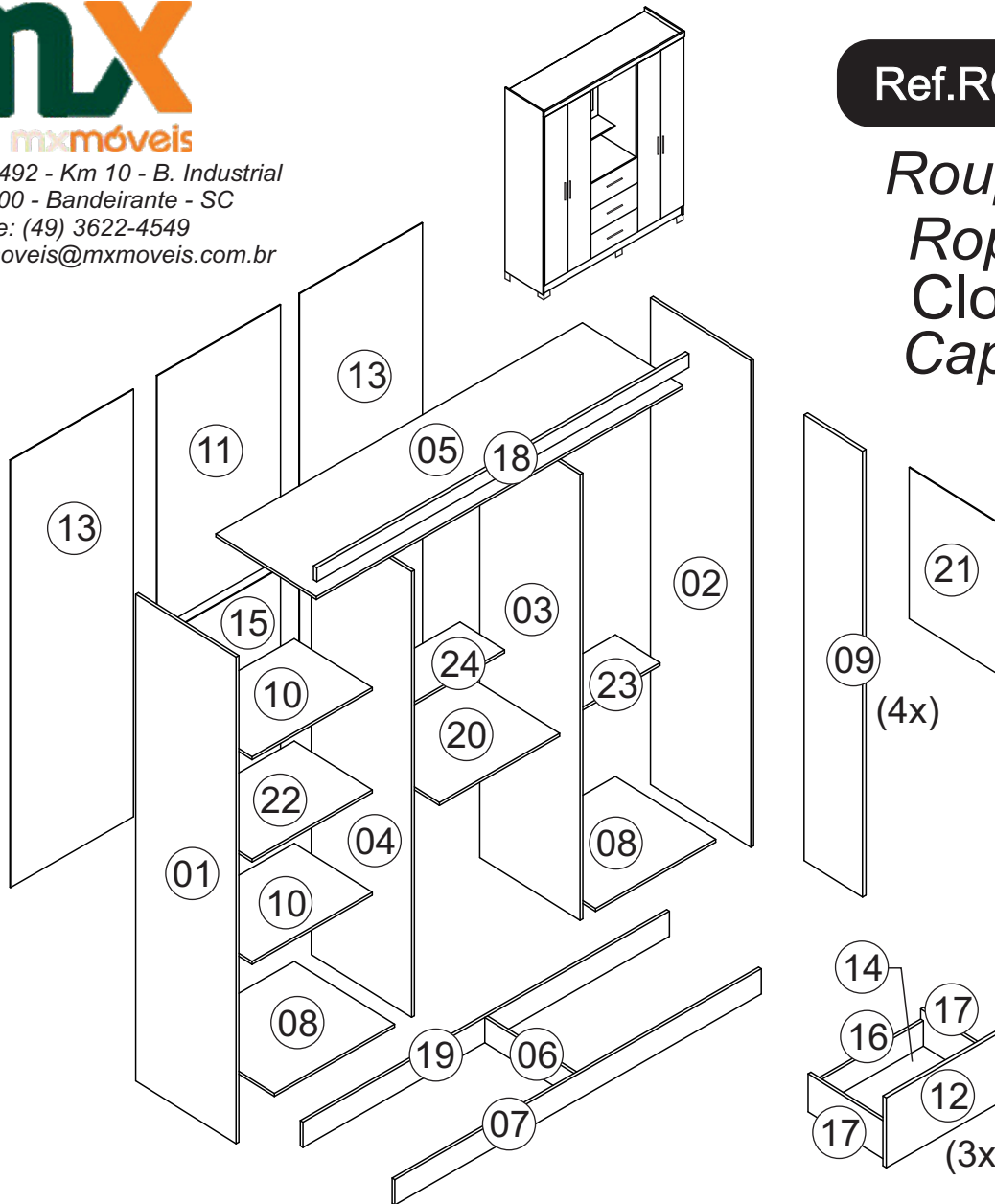

Rodovia SC-492 - Km 10 - B. Industrial
89905-000 - Bandeirante - SC
Fone: (49) 3622-4549
e-mail: mxmoveis@mxmoveis.com.br

Ref.RG139.E

Roupeiro
Ropero
Closet
Capella



Nº	CÓDIGO CODE ASSISTÊNCIA ATTENDANCE	NOME DA PEÇA/DESCRIPCIÓN PIEZAS/DESCRIPTION PARTS	MEDIDAS (mm) MEASURES (mm)	QTD.	MARROCOS OFF WHITE	BRANCO NEVE BRANCO NEVE
01	RG139.18.00	Lateral externa esquerda/Lateral izquierda/Left side	1850x450x12	01	274881	280573
02	RG139.17.00	Lateral externa direita/Lateral derecha/Right side	1850x450x12	01	274880	280572
03	RG139.19.00	Lateral interna direita/Lateral interna/Inner side	1680x450x12	01	280370	280553
04	RG139.19.01	Lateral interna esquerda/Lateral interna/Inner side	1680x450x12	01	274996	280554
05	RG139.05.00	Base superior/Base superior/Shelf	1500x450x12	01	274876	280569
06	RG139.31.00	Rodapé interno/Zócalo transversal	404x110x12	01	274885	274885
07	RG139.30.00	Rodapé frontal/Zócalo delantero/Front panel	1500x110x12	01	274884	280574
08	RG139.01.00	Base Inferior/Base/Shelf	476x450x12	02	280371	280566
09	RG139.25.00	Porta/Puerta/Door	1676x240x12	04	280380	280552
10	RG139.27.00	Prateleira/Plateira/Shelf	476x350x12	02	274882	274882
11	RG139.13.01	Forro espelho/ Revés espejo/Botton mirror	902x536x2.5	01	274860	280551
12	RG139.14.00	Frente de gaveta/ Frente del cajón/ Drawer front	532x250x12	03	278256	280571
13	RG139.13.00	Forro/Revés/botton	1680x488x2.5	02	274859	274859
14	RG139.34.00	Forro gaveta/Fondo cajón/Botton	499x355x2.5	03	274862	274862
15	RG139.13.02	Forro/Revés/botton	760x536x2.5	01	274994	274994
16	RG139.29.00	Traseiro de gaveta/Cajón	475x90x12	03	274883	274883
17	RG139.15.00	Lateral de gaveta/ Lado del cajón/	350x110x12	06	274879	274879
18	RG139.07.00	Chapéu/Detalle superior/Hat	1524x53x12	01	274877	280570
19	RG139.32.00	Rodapé traseiro/Zócalo de atrás/Border back	1500x110x12	01	274886	274886
20	RG139.04.00	Base sob gaveta/Base/Shelf	524x450x12	01	274875	280568
21	4946	Espelho/Espejo/Mirror	600x400x3	01		
22	RG139.02.00	Base lateral/Base/Shelf	476x350x12	01	274997	274997
23	RG139.02.01	Base meia/Base/Shelf	476x200x12	01	276614	276614
24	RG139.02.02	Base meia/Base/Shelf	524x200x12	01	276615	280567

Ferragens/Herrajes/Hardware

A  **24x**
Cód 873
Cavilha/Clavija/Peg Ø 6,0x30mm

B  **46x**
Cód 691
Parafuso/Tornillo/Screw 3,5x40mm Chat

C  **50x**
Cód 11413
Parafuso/Tornillo/Screw 3x12mm Chat

D  **08x**
Cód 790
Suporte prateleira/ Soporte de estante/ Shelf support

E  **18x**
Cód 667
Parafuso/Tornillo/Screw 4x14mm Chat

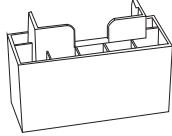
F  **06x**
Cód 4083
Cód 3785
Pé plástico/Pie de plástico/Plastic foot

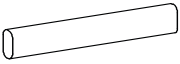
G  **02x**
Cód 12153
Cabideiro/Tendedeiro/Wooden hanger 488mm

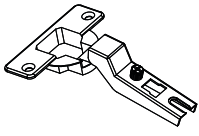
H  **12x**
Cód 10269
Dobradiça/Visagra/Metal hinge

I  **24x**
Cód 7169
Fixador costa/Ujetador de orilla/Shore fastener

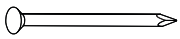
J  **91x**
Cód 822
Prego/Clavo/Nail

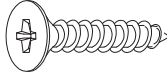
K  **14x**
Cód 874
Parafuso/Tornillo/Screw 3,5x22mm Chat

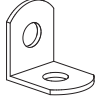
L  **13x**
Cód 7168
Cantoneira metálica/angulo metálico
Metal angle bracket

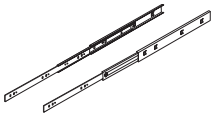
M  **03x**
Cód 20253
Corrediças/Diapostivas/Slides

N  **07x**
Cód 12154
Puxador/Manija/Puller

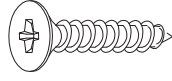
O  **12x**
Cód 9567
Parafuso/Tornillo/Screw 3x22mm Chat

P  **12x**
Cód 12539
Calço dobradiça/Calzo de visagra/ Chock to hinge

Q  **48x**
Cód 7604
Parafuso/Tornillo/Screw 4x12mm Chat

R  **01x**
Cód 8255
Bisnaga cola/tubo de pegamento/glue tube

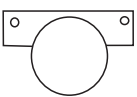
S  **12x**
Cód 10483
Distanciador de dobradiça / Distanciador de Visagra

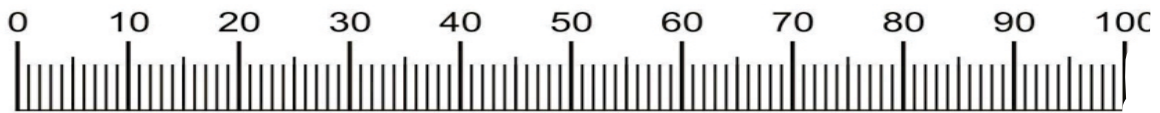

Medidas em mm
Measures in mm
Mesuras en mm

 **Giz para madeira**
Produto para ser aplicado em caso de riscas na superfície.

 **Giz para madeira**
Product to be applied in case of scratches on the surface.

 **Giz para madeira**
Producto para ser aplicado en caso de rayas en la superficie.

   **1:00**  

Pré-Montagem/Preparación Piezas/ Pre-assembly

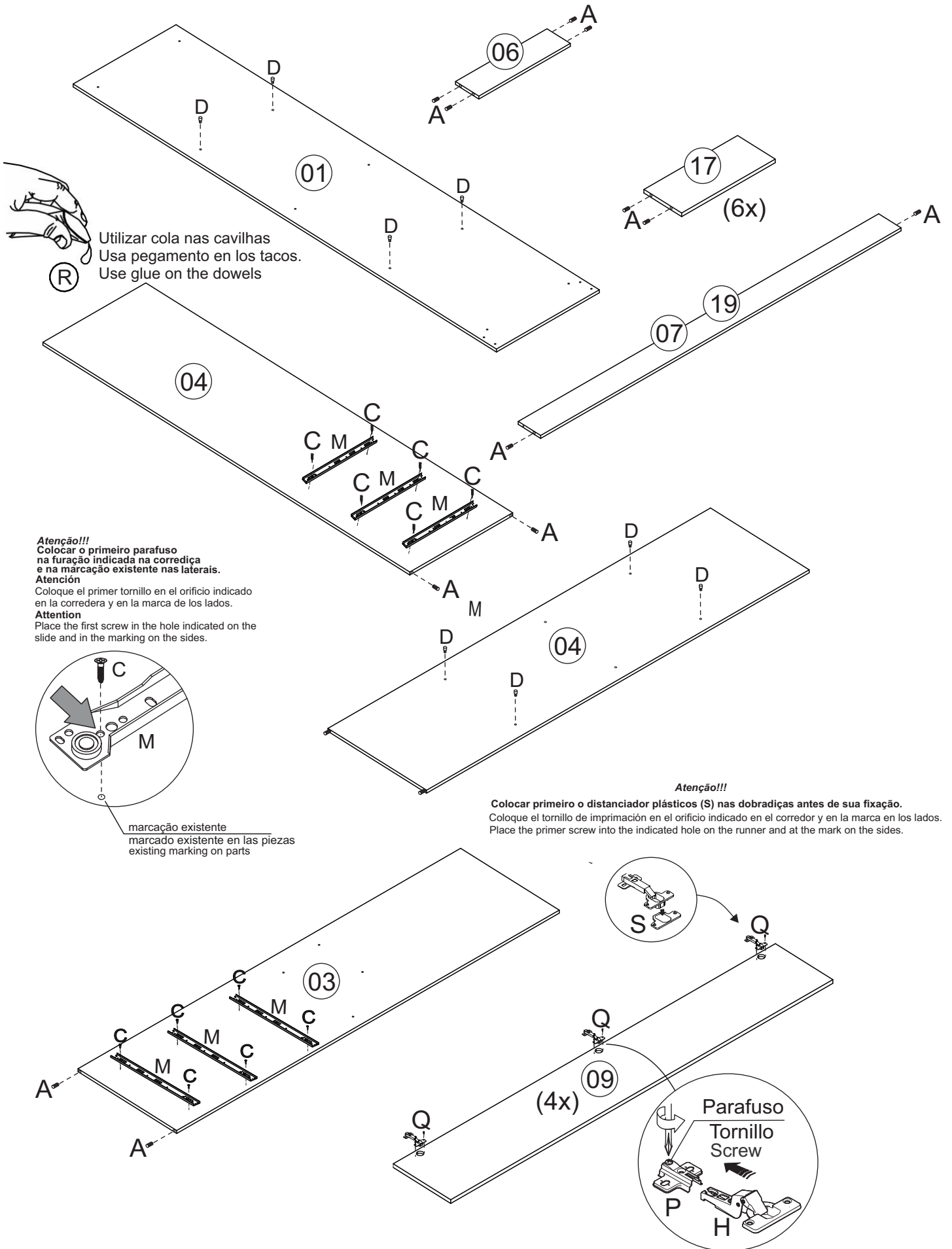

(R) Utilizar cola nas cavilhas
 Usa pegamento en los tacos.
 Use glue on the dowels

Atenção!!!
 Colocar o primeiro parafuso na furação indicada na corredeira e na marcação existente nas laterais.

Atención
 Coloque el primer tornillo en el orificio indicado en la corredera y en la marca de los lados.

Attention
 Place the first screw in the hole indicated on the slide and in the marking on the sides.

marcação existente
 marcado existente en las piezas
 existing marking on parts

Atenção!!!

Colocar primeiro o distanciador plástico (S) nas dobradiças antes de sua fixação.
 Coloque el tornillo de imprimación en el orificio indicado en el corredor y en la marca en los lados.
 Place the primer screw into the indicated hole on the runner and at the mark on the sides.

Parafuso
 Tornillo
 Screw

01 Montagem/Montaje/Assembly

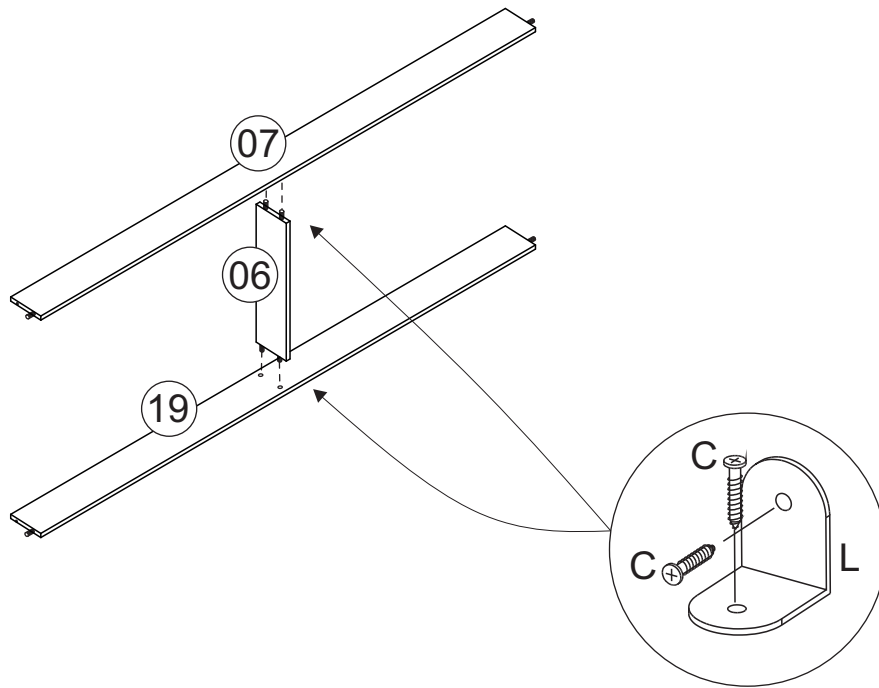

02

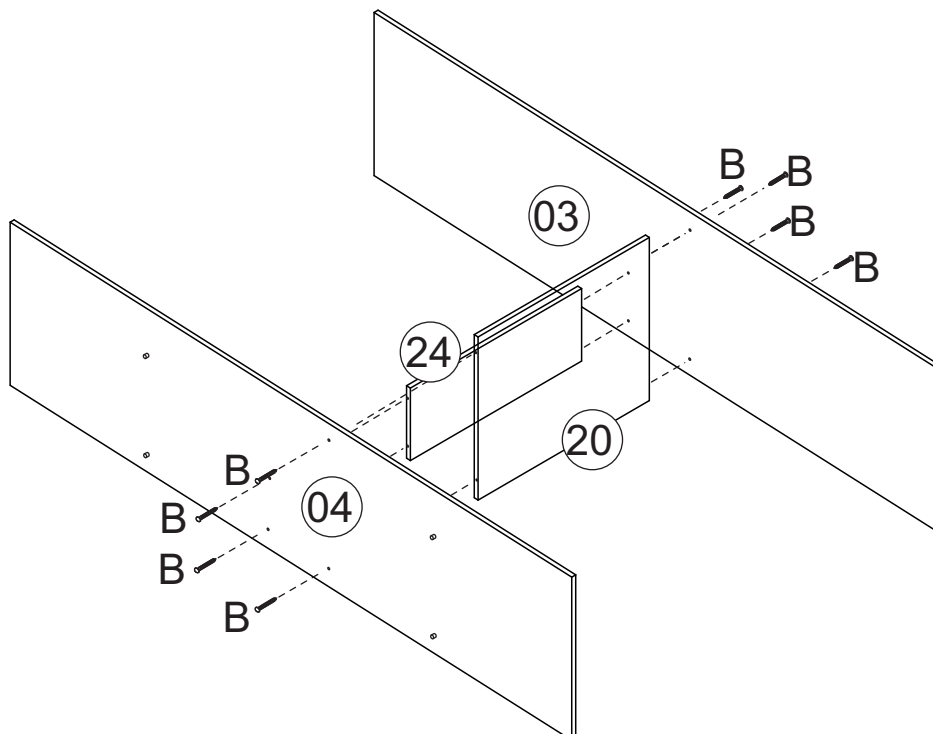

03 Montagem/Montaje/Assembly

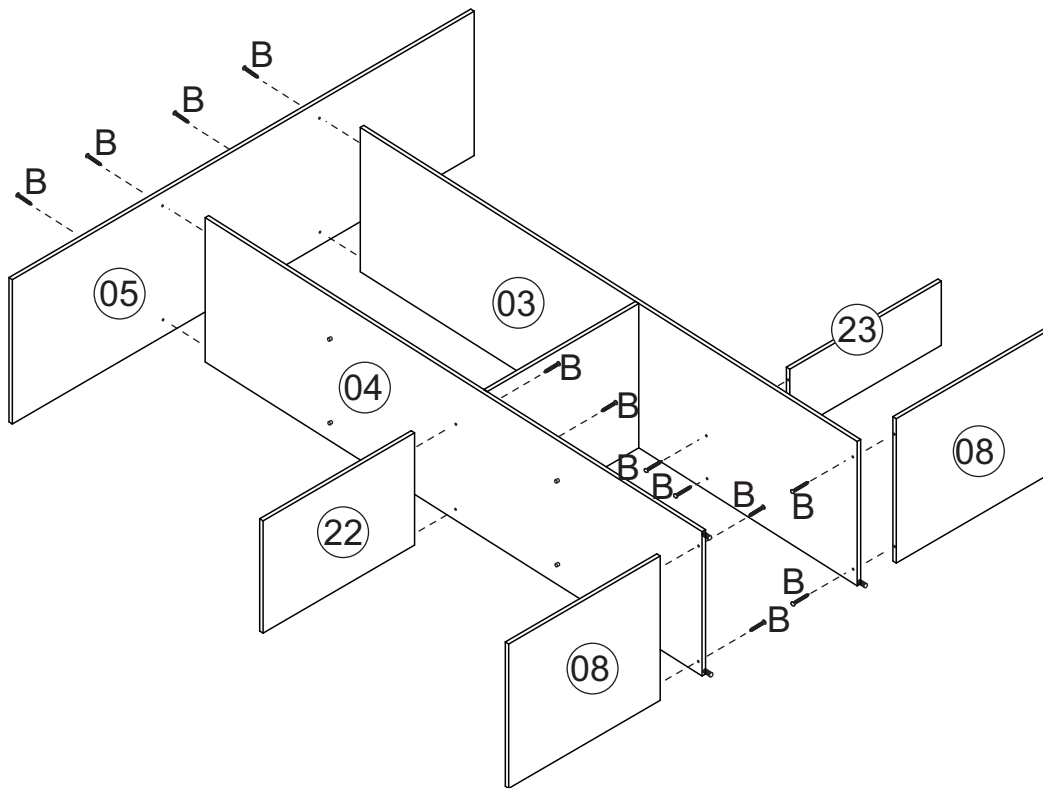

04

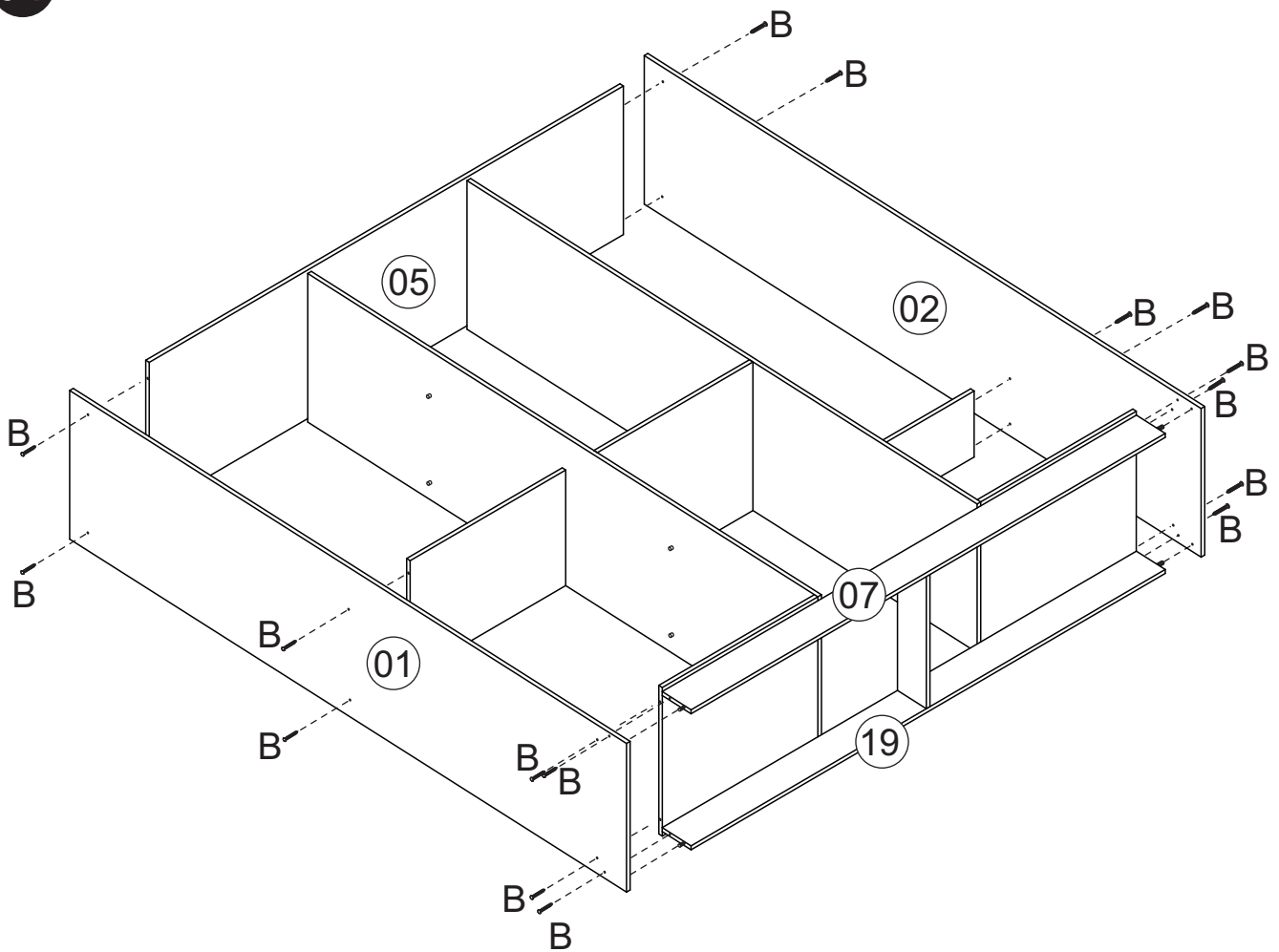

05 Montagem/Montaje/Assembly

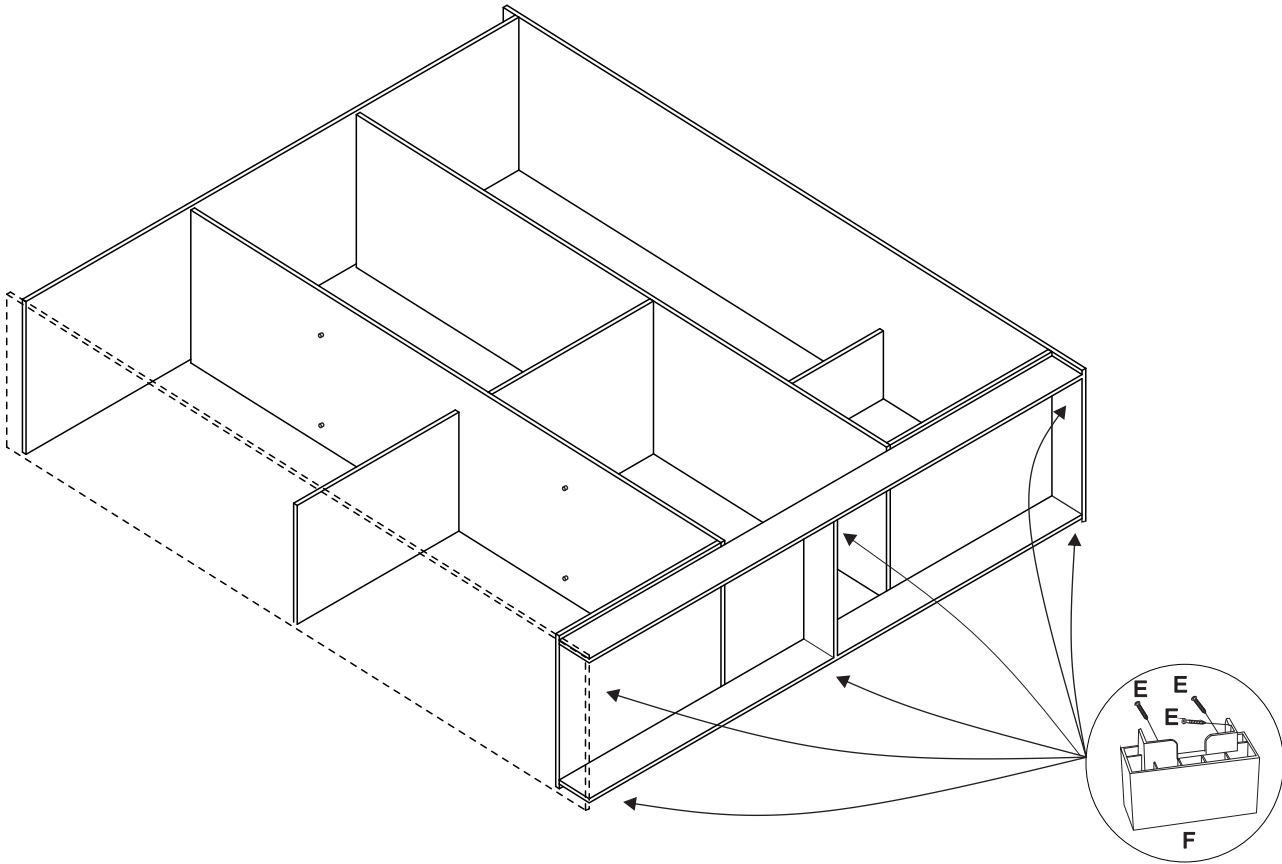

06

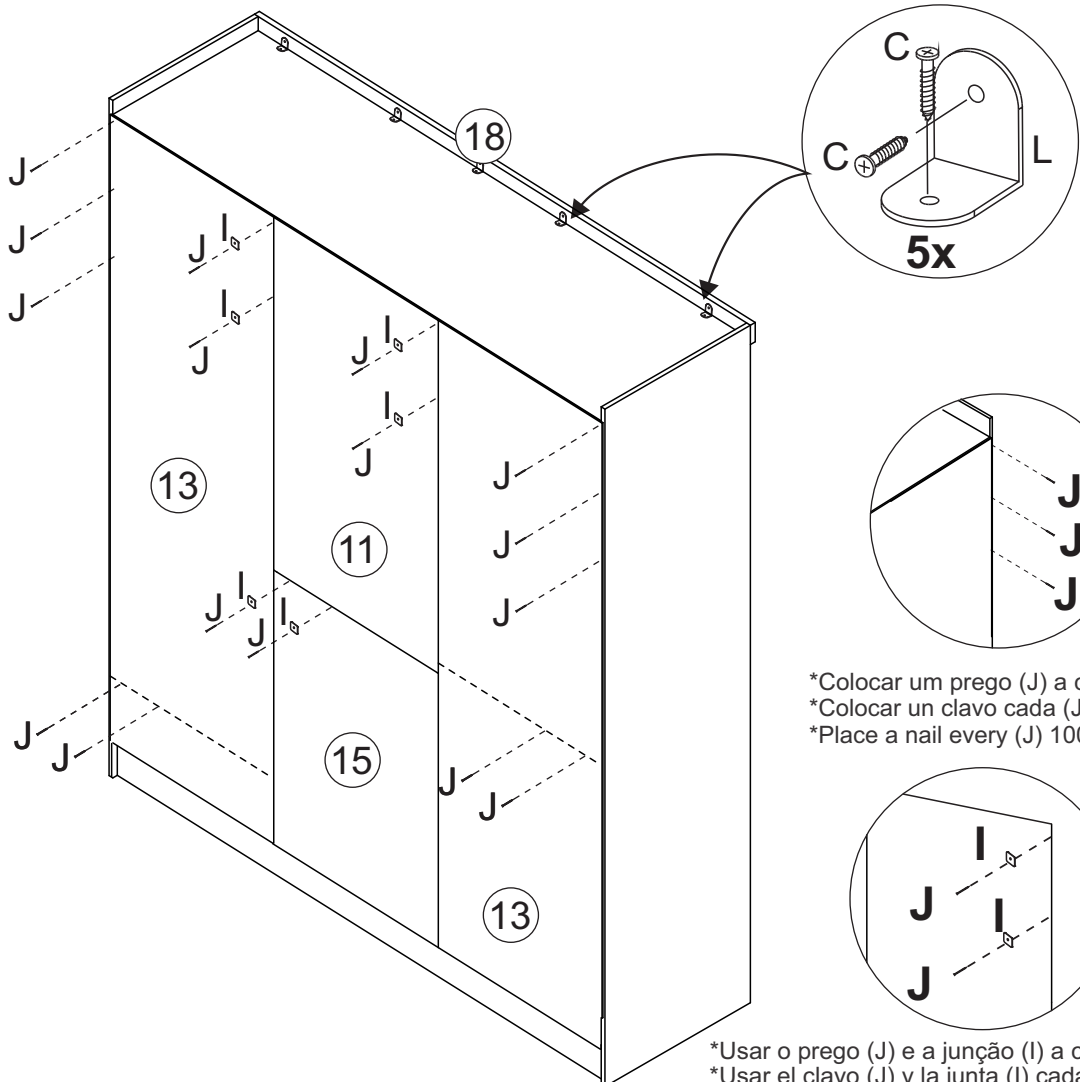

*Colocar um prego (J) a cada 100mm
 *Colocar un clavo cada (J) 100mm
 *Place a nail every (J) 100mm

*Usar o prego (J) e a junção (I) a cada 150mm
 *Usar el clavo (J) y la junta (I) cada 150mm
 *Use the nail (J) and the joint (I) every 150mm

07 Montagem/Montaje/Assembly

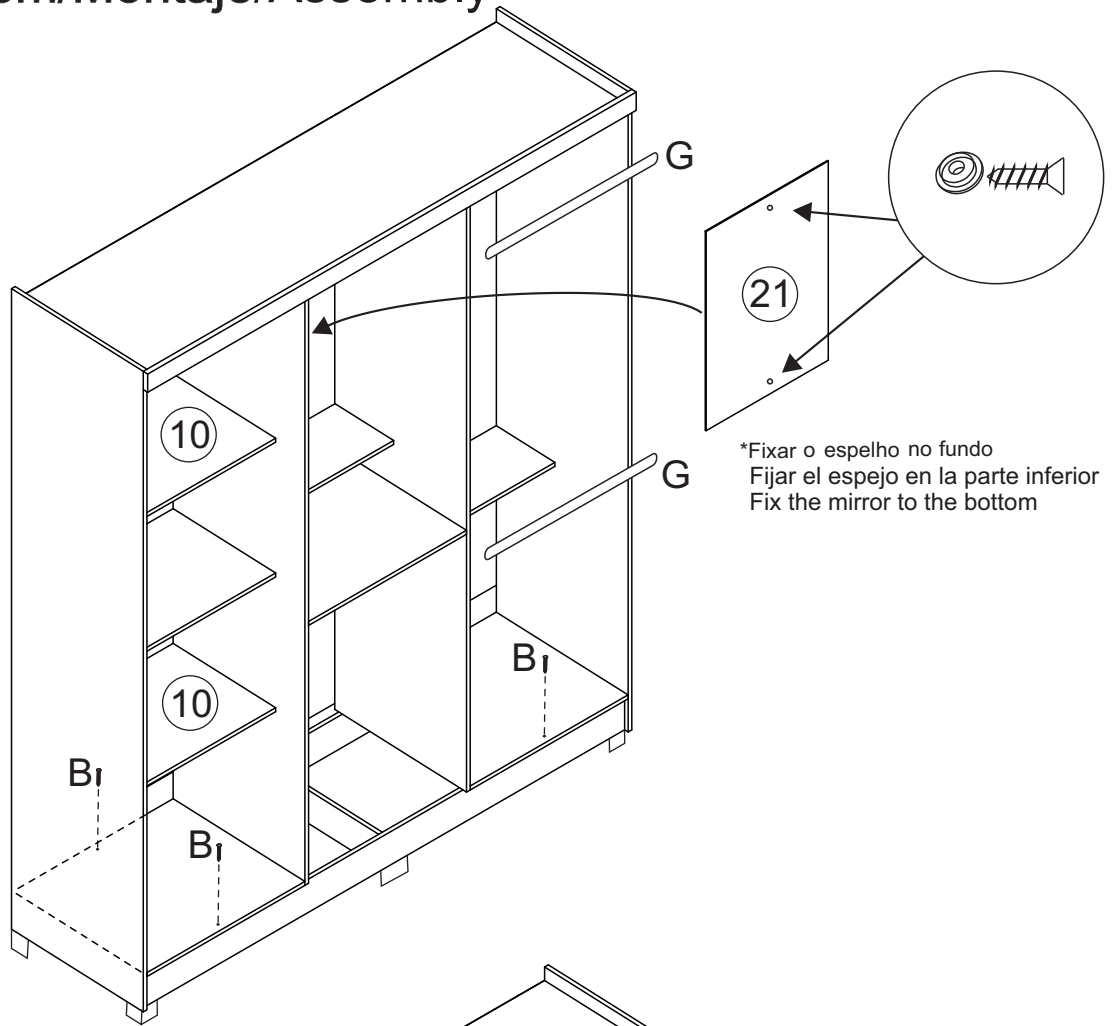

08

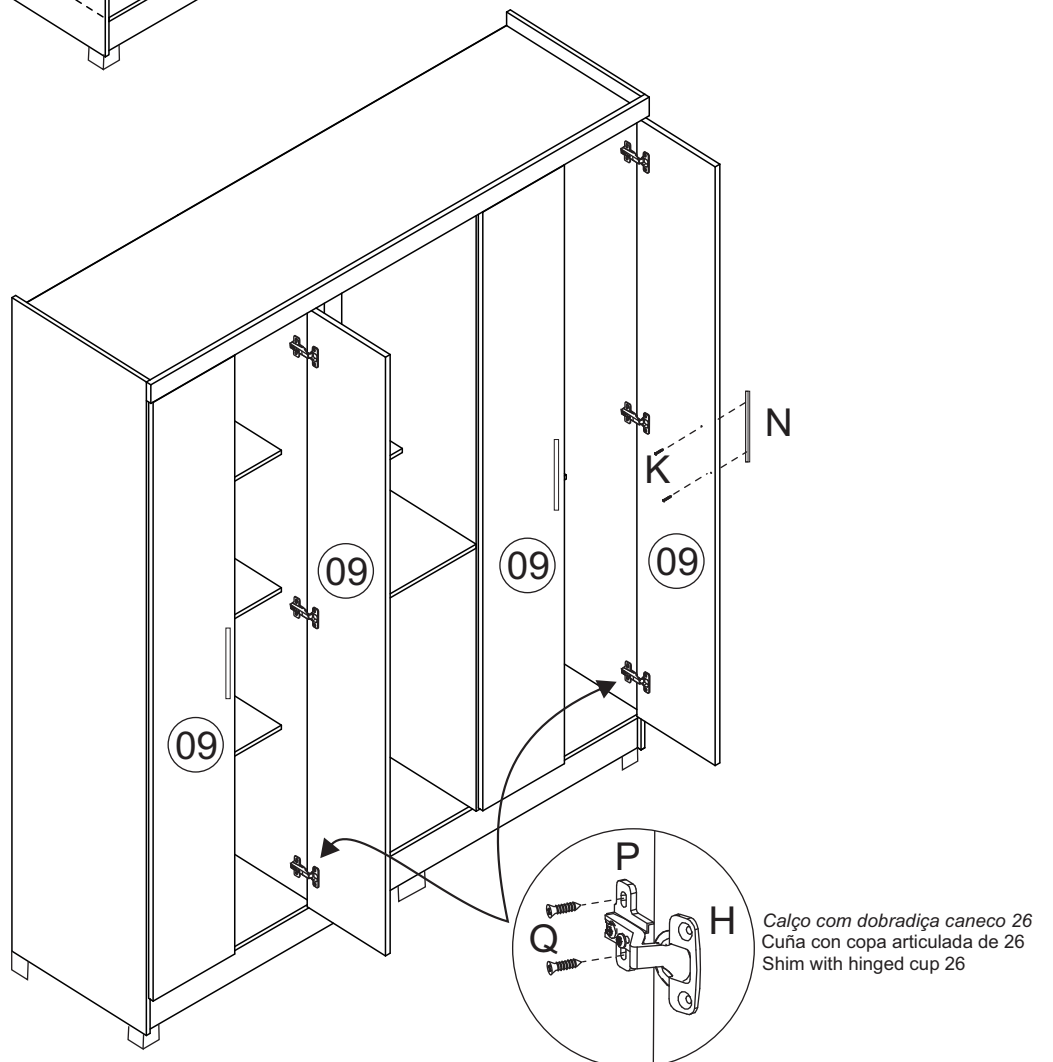

09 Montagem/Montaje/Assembly

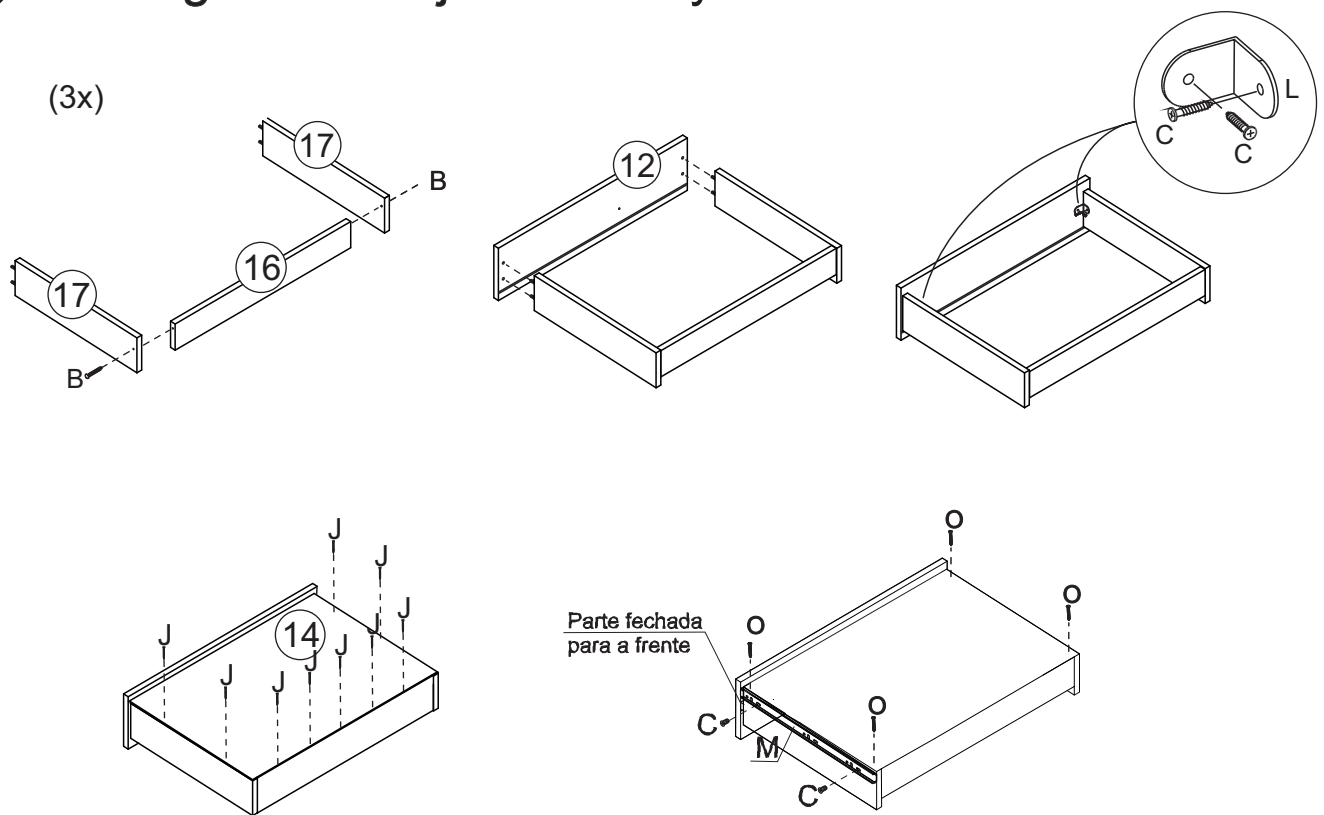

10

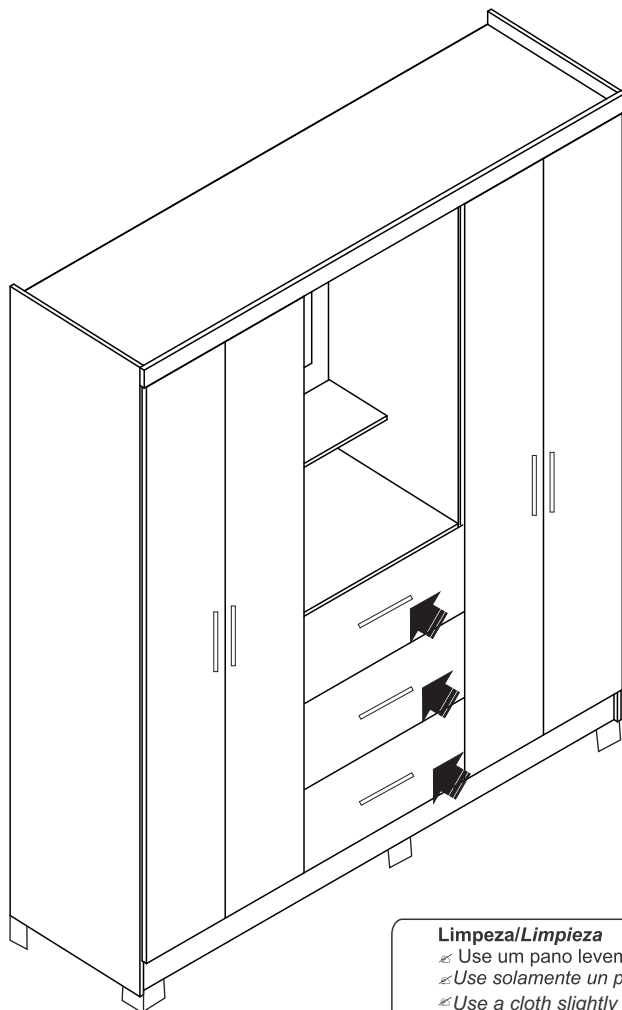

Limpeza/Limpieza

- ≠ Use um pano levemente umedecido com água, seguido de pano seco.
- ≠ Use solamente un paño húmedo con agua y después un paño seco.
- ≠ Use a cloth slightly dampened with water, followed by a dry cloth.
- ≠ Nunca utilize produtos químicos ou abrasivos.
- ≠ No utilice productos químicos o abrasivos.
- ≠ Never use chemical or abrasive products.