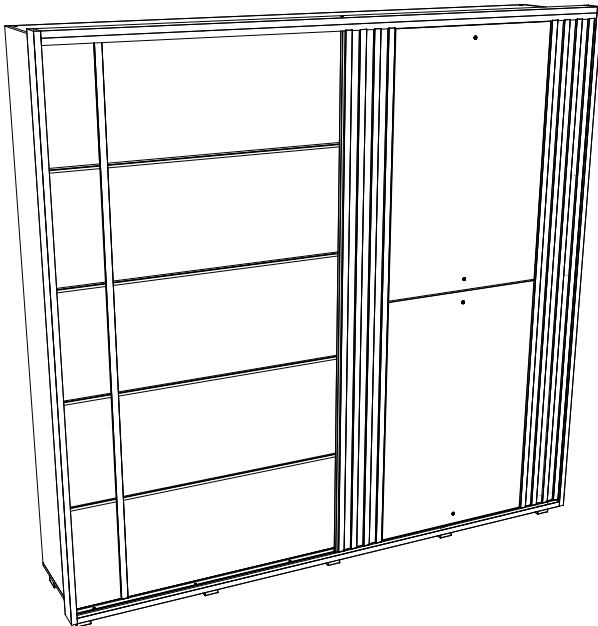
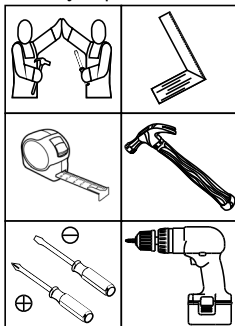

**HENN**Ind. e Com. de Móveis Henn  
Mondai - SC - Brasil

☎ +55 49 3674.3500

📷 @moveishenn  
www.henn.com.br**INSTRUÇÕES DE  
MONTAGEM****INSTRUCCIONES DE MONTAJE  
ASSEMBLY INSTRUCTIONS****Roupeiro Havaí 2 Portas Deslizantes | Roupeiro Havaí 2 Puertas de Correr |  
Roupeiro Havaí 2 Sliding Gates****D306-108 Duna/Off White  
D306-198 Jequitibá Brilho****Requisitos para montagem  
Assembly Requirements**

Imagens meramente ilustrativas,  
não acompanha o produto.  
Imágenes ilustrativas, no incluidas  
con el producto.  
Illustrative images, not included  
with the product.

**AVISO**

Para limpeza de seu móvel, use uma flanela seca ou umedecida, e não utilize produtos químicos que possam danificar seu produto.

**SISTEMA DE MONTAGEM**

O sistema de montagem dos produtos, funciona de acordo com a ordem crescente dos números indicados no desenho. Ex: 01, 02, 03, 04... até a conclusão da montagem.

**ASSISTÊNCIA TÉCNICA**

Para solicitação de Assistência Técnica você consumidor deverá entrar em contato com o Lojista o qual você realizou a compra deste produto e solicitar a assistência técnica das peças avariadas. A garantia abrange todas as peças, partes e componentes que eventualmente venham apresentar defeito de fabricação no prazo de 03 (três) meses, contando a partir da entrega do produto ao consumidor, mediante nota fiscal de compra. Se houver qualquer alteração na estrutura do produto ou ocorrer defeito por negligência do montador/consumidor em relação a instrução de montagem e manuseio, não será fornecido assistência técnica gratuita.

**ADVERTENCIA**

Para limpeza de su móvil, use una flanela seca o húmeda, y no utilice productos químicos que puedan dañar su producto.

**SISTEMA DE MONTAJE**

El sistema de montaje de los productos funciona de acuerdo con el orden creciente de los números indicados en el dibujo. Ej.: 01, 02, 03, 04... hasta la conclusión del montaje.

**ASISTENCIA TÉCNICA**

Para solicitar Asistencia Técnica, el consumidor debe comunicarse con el Comercio que usted realizó la compra de este producto y solicita asistencia técnica para las partes dañadas. La garantía cubre todas las partes, piezas y componentes que eventualmente puedan presentar defecto de fabricación en el plazo de 03 (tres) meses, contados a partir de la entrega del producto al consumidor, mediante factura de compra. Si se produce algún cambio en la estructura del producto o se produce un defecto por negligencia del montador/consumidor en relación con las instrucciones de montaje y manipulación, no se prestará asistencia técnica gratuita.

**NOTICE**

To clean your furniture, use a dry or wet cloth, and do not use chemicals that may damage your product.

**ASSEMBLY SYSTEM**

The products' assembly system works according to the increasing order of the indicated numbers. For example: 01, 02, 03, 04 ... to the end of the assembly.

**TECHNICAL ASSISTANCE**

To request Technical Assistance, the consumer must contact the retailer from whom you purchased this product and request technical assistance for the damaged parts. The warranty covers all parts, parts and components that may eventually present a manufacturing defect within a period of 03 (three) months, counting from the delivery of the product to the consumer, by means of a purchase invoice. If there is any change in the structure of the product or defect occurs due to negligence of the assembler/consumer in relation to the assembly and handling instruction, free technical assistance will not be provided.

## ACESSÓRIOS | ACCESORIOS | ACCESSORIES

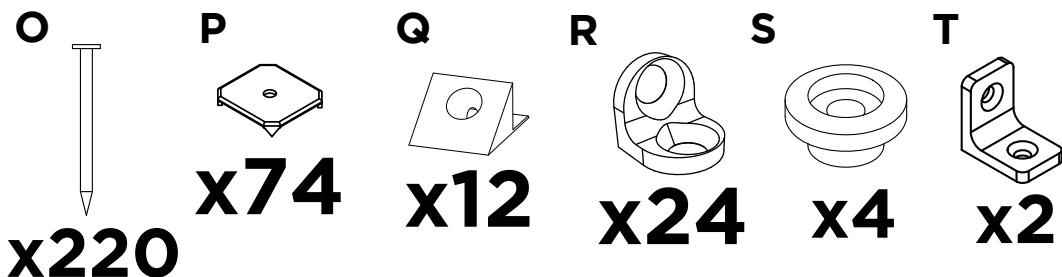
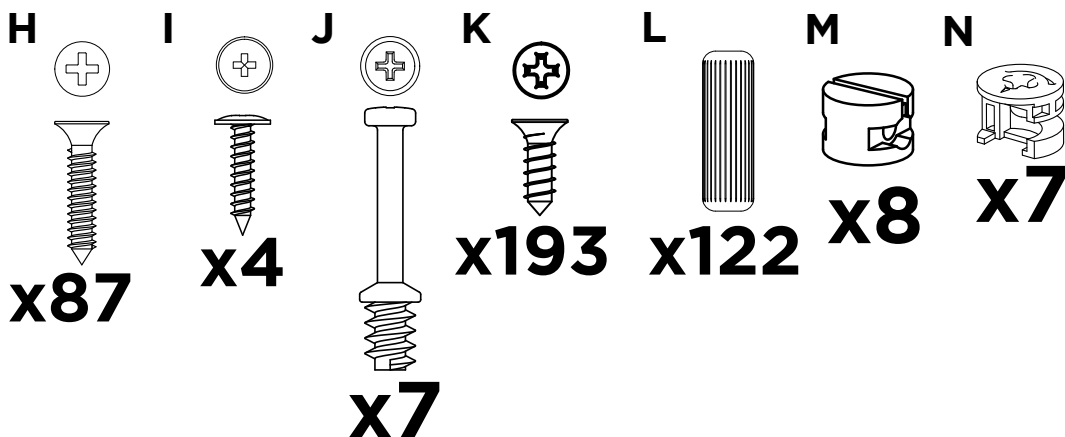
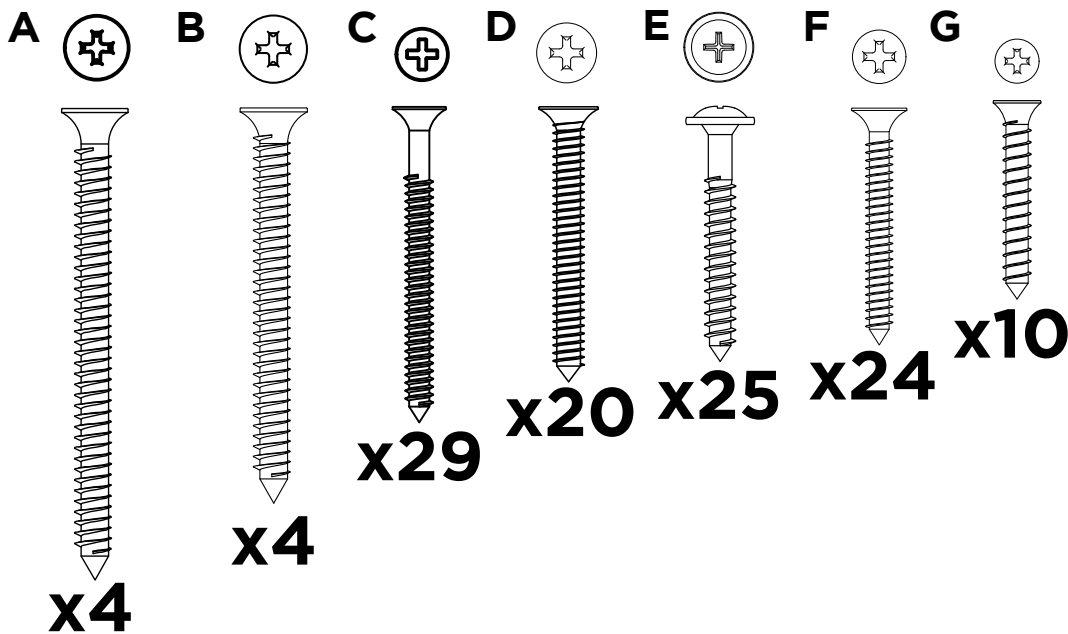

Parafusos em escala  
Tornillos escalados  
Scaled screws

1:1

## ACESSÓRIOS | ACCESORIOS | ACCESSORIES

U

**x16**

V

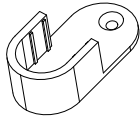
**x6**

W

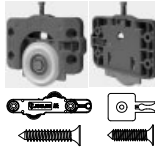
**x1**

X

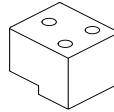
**x10**

Y

**x3**

Z

**x6**

AA

**x4**

AB

**x4**

AC

**x1**

AD

**x1**

AE

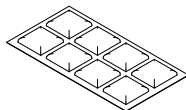
**x16**

AF

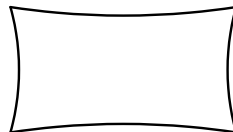
**x3**

AG

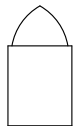
**x2**

AH

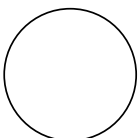
**x8**

AI

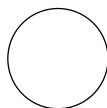
**x28**

AJ

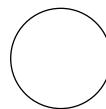
**x52**

AK

**x1**

## LISTA DE PEÇAS | LISTA DE PIEZAS | LIST OF PIECES

Item	Caixa Caja Box	Qty Ctd Qty	Descrição Descripción Description	Dimensões (mm)   Dimensiones (mm)   Dimensions (mm)		
				Comprimento Largo Length	Largura Ancho Width	Espes- sura Grosor Thick- ness
1	2/6	1	BASE   BASE   BASE	2381	440	15
2	1/6	2	TRAVESSA LATERAL BASE   CARRIL LATERAL BASE   BASE SIDE CROSSBAR	420	90	15
3	1/6	3	TRAVESSA CENTRAL BASE   CARRIL CENTRAL BASE   CENTRAL BASE RAIL	420	70	15
4	2/6	1	TRAVESSA FRONTAL BASE   CARRIL DELANTERA DE LA BASE   BASE FRONT CROSSBAR	2411	90	25
5	3/6	1	TAMPO DAS GAVETAS ESQUERDA   PARTE SUPERIOR DEL CAJÓN IZQUIERDO   LEFT DRAWER TOP	599	400	15
6	1/6	1	DIVISÃO ESQUERDA MENOR   DIVISIÓN IZQUIERDA MENOR   MINOR LEFT DIVISION	985	355	15
7	3/6	1	TAMPO DAS GAVETAS DIREITA   PARTE SUPERIOR DEL CAJÓN DERECHO   RIGHT DRAWER TOP	599	400	15
8	1/6	1	DIVISÃO DIREITA MENOR   DIVISIÓN DE DERECHO MENOR   MINOR RIGHT DIVISION	985	355	15
9	3/6	1	LATERAL ESQUERDA   LATERAL IZQUIERDA   LEFT SIDE	2300	440	15
10	1/6	1	DIVISÃO GAVETA ESQUERDA   DIVISIÓN DEL CAJÓN IZQUIERDO   LEFT DRAWER DIVISION	841	400	15
11=15	3/6	2	PRATELEIRA   ESTANTE   SHELF	584	350	15
12	3/6	1	DIVISÃO CENTRAL   DIVISIÓN CENTRAL   CENTRAL DIVISION	1841	420	15
13	2/6	1	PRATELEIRA DO CALCEIRO   ESTANTE DE CALCEIRO   CALCEIRO'S SHELF	584	250	15
14	1/6	1	DIVISÃO GAVETA DIREITA   DIVISIÓN DEL CAJÓN DERECHO   RIGHT DRAWER DIVISION	841	400	15
15=11	3/6	4	PRATELEIRA   ESTANTE   SHELF	584	350	15
16	4/6	1	CHÃO DO MALEIRO   PISO DEL PORTA EQUIPAJES   FLOOR OF THE CLOSET TOP SHELF	2381	420	15
17	3/6	1	RIPA DO MALEIRO   LISTÓN DAL ARMARIO DE EQUIPAJE   CLAPBOARD LUGGAGE LOCKER	414	73	15
18	2/6	1	TAMPO SUPERIOR   TAPA SUPERIOR   TOP PANEL	2381	440	15
19	3/6	1	LATERAL DIREITA   LATERAL DERECHA   RIGHT SIDE	2300	440	15
20	2/6	1	FUNDO SUPERIOR   FONDO SUPERIOR   SUPERIOR	2405	436	3
21	4/6	8	FUNDO   FONDO   BACKGROUND	1863	296	3
22	2/6	2	MOLDURA LATERAL   MARCO LATERAL   SIDE FRAME	2350	90	25
23	2/6	1	MOLDURA SUPERIOR   MARCO SUPERIOR   UPPER FRAME	2411	90	25
24	5/6	2	PAINEL INFERIOR SUPERIOR   PANEL INFERIOR SUPERIOR   TOP PANEL BOTTOM	1220	453	12
25	5/6	3	PAINEL   PANEL   PANEL	1220	453	12
26=30	4/6	1	APLIQUE   APLICARSE   APPLY	2263	28	9
27	4/6	1	PAINEL ESPELHO   PANEL ESPEJO   MIRROR PANEL	2265	995	12
28	6/6	2	ESPELHO   ESPEJO   MIRROR	1124	750	3
29	4/6	1	PAINEL DIREITO MENOR   PANEL DERECHO MÁS PEQUEÑO   SMALLER RIGHT PANEL	2265	225	12
30=26	4/6	8	APLIQUE   APLICARSE   APPLY	2263	28	9
31	4/6	1	TRAVESSA DA PORTA   TRAVESAÑO DE LA PUERTA   DOOR CROSSBAR	2214	68	9
32	1/6	6	RIPA DE TRÁS   MALLA DETRÁS   REAR LAHT	559	180	15
33	2/6 e 4/6	12	LADO DE GAVETA   LADO DEL CAJÓN   SIDE OF DRAWER	350	180	15
34	3/6	6	FUNDO DE GAVETA RECORTADO   FONDO DEL CAJÓN RECORTADO   CROPPE DRAWER BOTTOM	540	361	3
35	2/6 e 4/6	6	FRENTE DE GAVETA   FRENTE DE CAJÓN   FRONT OF DRAWER	576	192	15

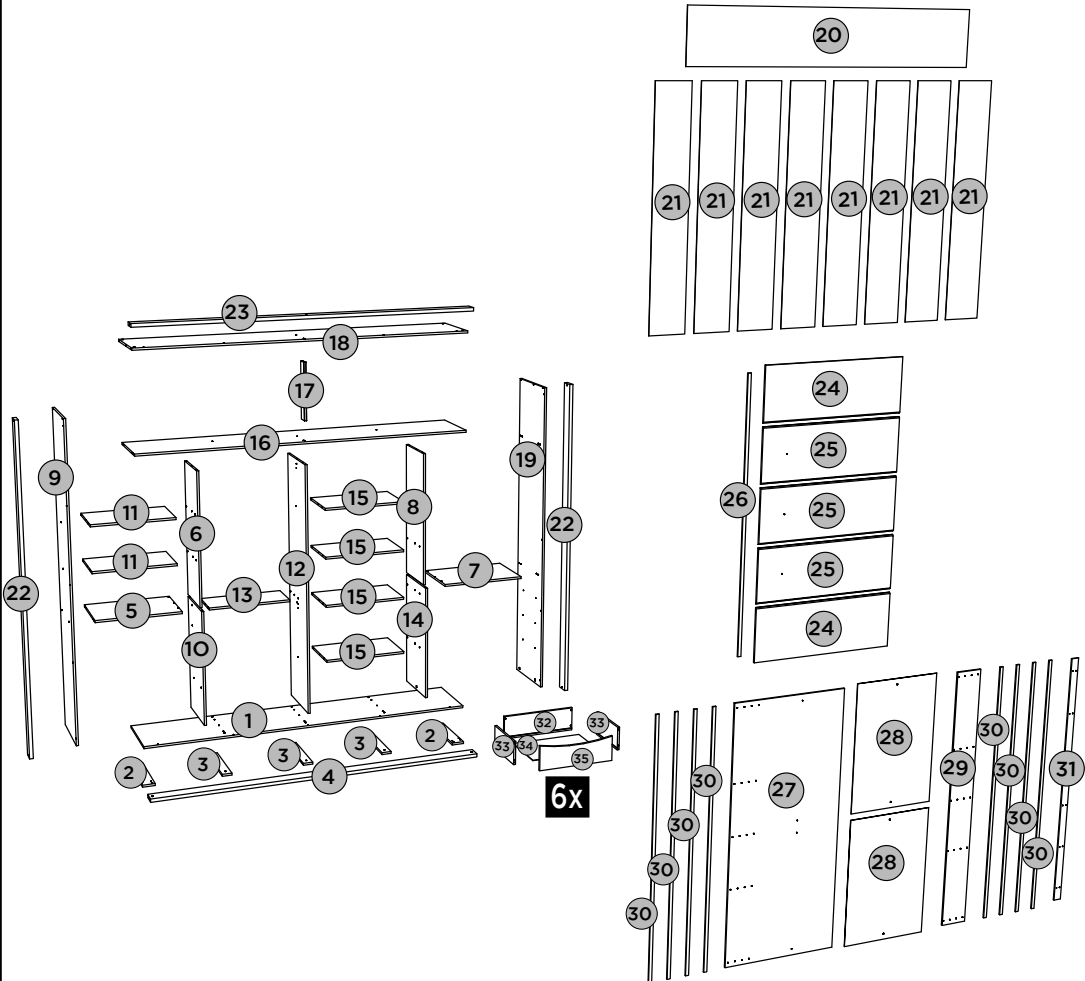

# LISTA DE PEÇAS | LISTA DE PIEZAS | LIST OF PIECES



## PEÇAS REQUERIDAS

1	BASE	x1
2	TRAVESSA LATERAL BASE	x2
4	TRAVESSA FRONTAL BASE	x1
16	CHÃO DO MALEIRO	x1
17	RIPA DO MALEIRO	x1
18	TAMPO SUPERIOR	x1
23	MOLDURA SUPERIOR	x1

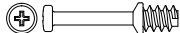
## ACESSÓRIOS REQUERIDOS

L		08
J		07
M		08

## FERRAMENTAS NECESSÁRIAS

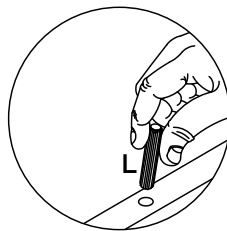
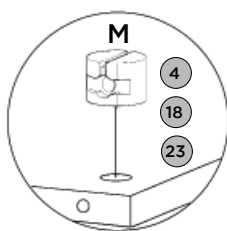
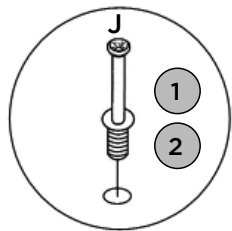
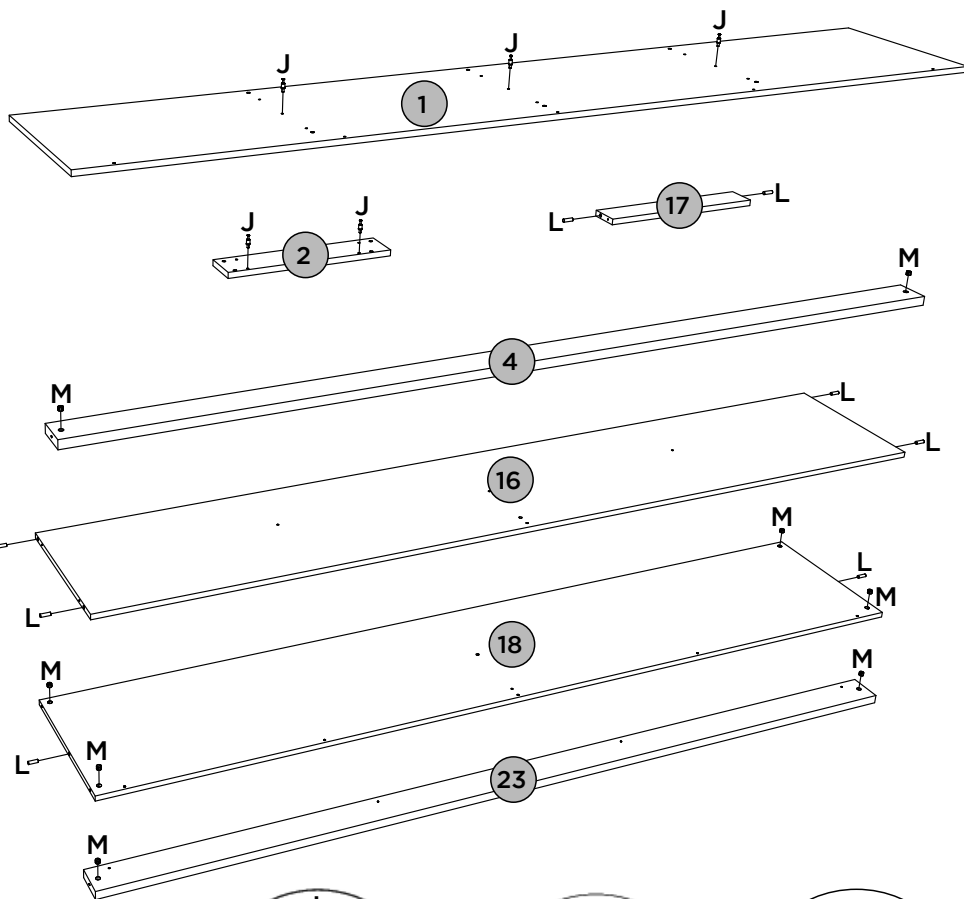
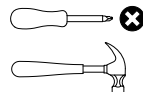





# PASSO 2

## PEÇAS REQUERIDAS

5	TAMPO DAS GAVETAS ESQUERDA	x1
6	DIVISÃO ESQUERDA MENOR	x1
7	TAMPO DAS GAVETAS DIREITA	x1
8	DIVISÃO DIREITA MENOR	x1
9	LATERAL ESQUERDA	x1
10	DIVISÃO GAVETA ESQUERDA	x1

## ACESSÓRIOS REQUERIDOS

K		24
L		18
V		03
Z		06

## FERRAMENTAS NECESSÁRIAS

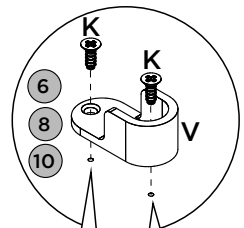
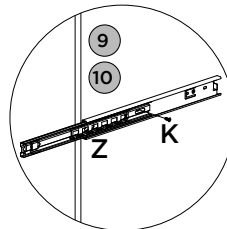
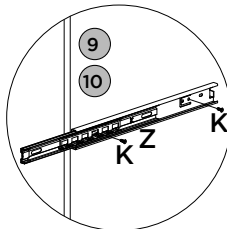
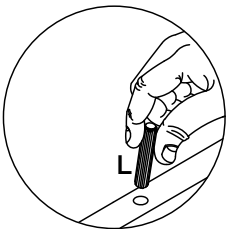
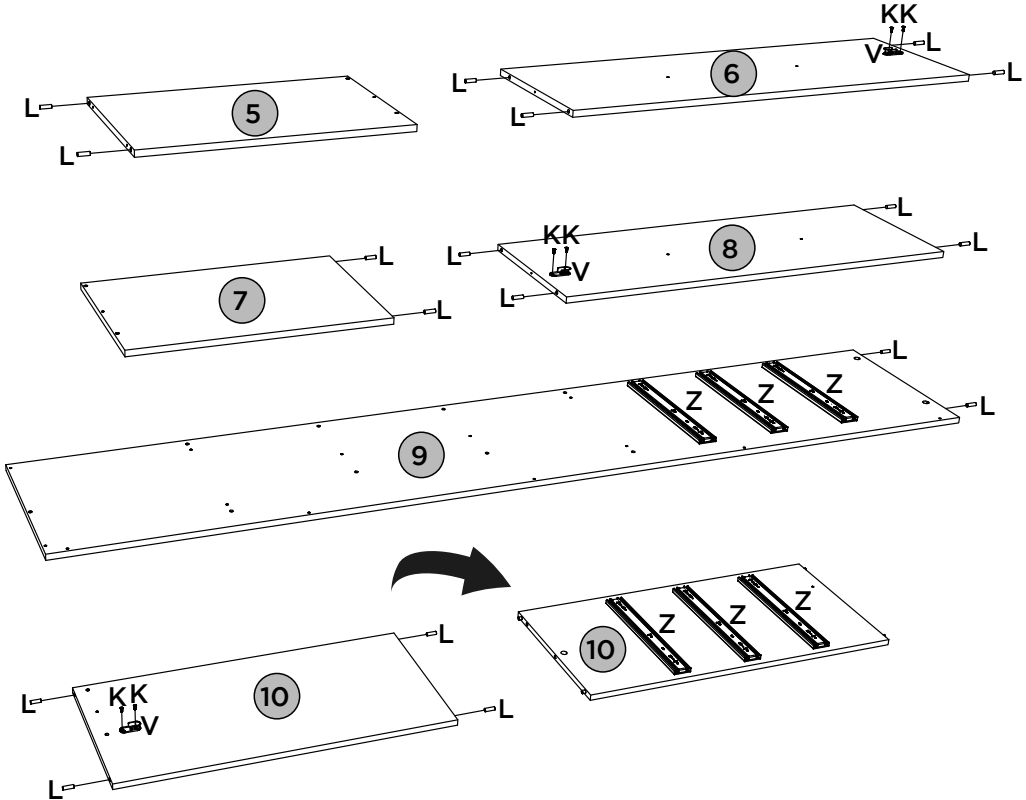
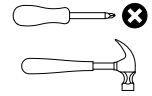





**Observe:  
Furos  
pré-marcados**

**PASSO 3****PEÇAS REQUERIDAS**

11=15	PRATELEIRA	x6
12	DIVISÃO CENTRAL	x1
13	PRATELEIRA DO CALCEIRO	x1
14	DIVISÃO GAVETA DIREITA	x1
19	LATERAL DIREITA	x1

**ACESSÓRIOS REQUERIDOS**

K		24
L		38
V		03
Z		06

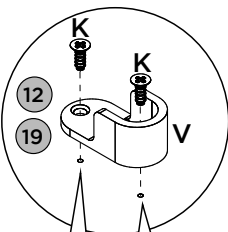
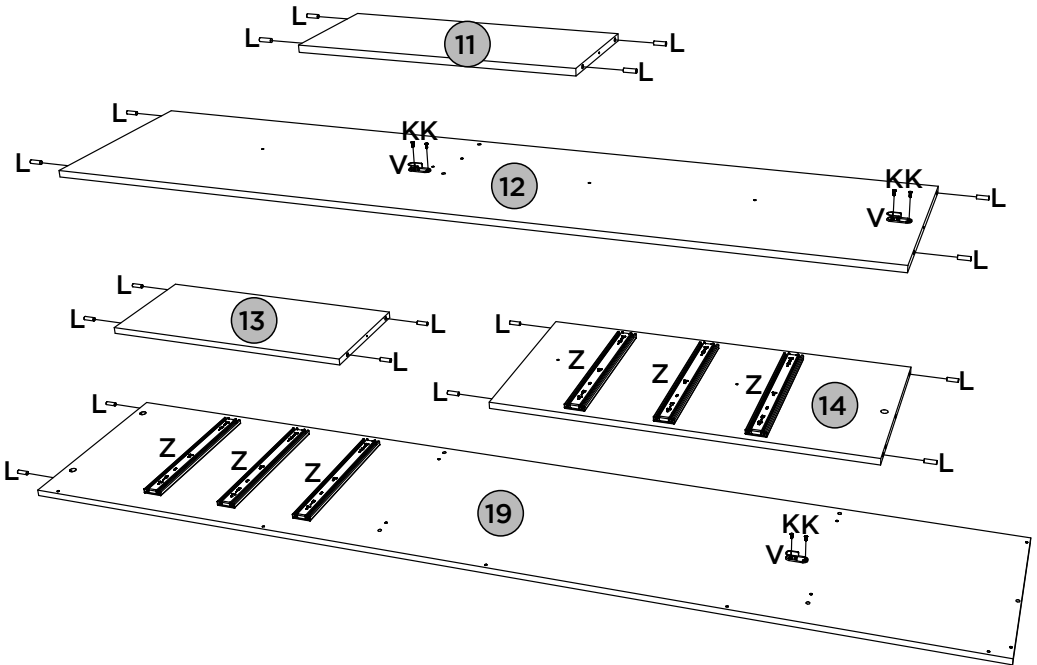
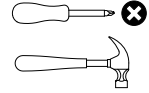
**FERRAMENTAS NECESSÁRIAS**

**Observe:  
Furos  
pré-marcados**

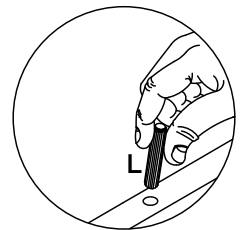
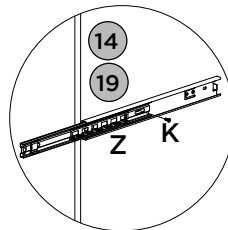
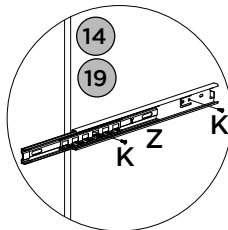





**PASSO 4****PEÇAS REQUERIDAS**

1	BASE	x1
2	TRAVESSA LATERAL BASE	x2
3	TRAVESSA CENTRAL BASE	x3

**ACESSÓRIOS REQUERIDOS**

G		10
L		10

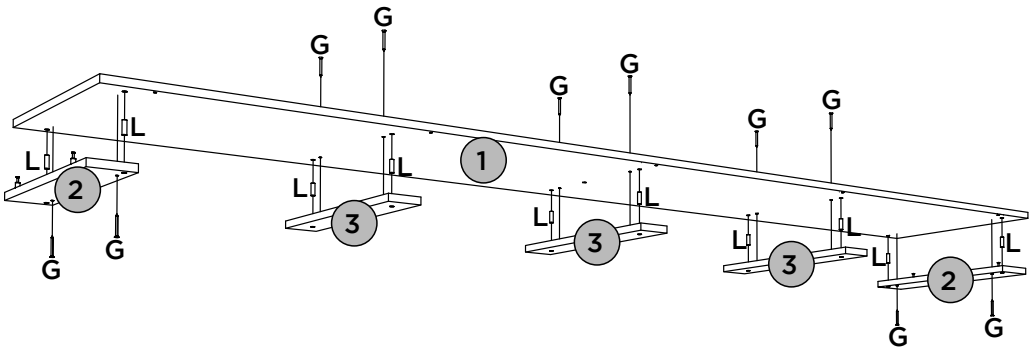
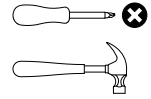
**FERRAMENTAS NECESSÁRIAS****PASSO 5****PEÇAS REQUERIDAS**



4	TRAVESSA FRONTAL BASE	x1
---	-----------------------	----

**ACESSÓRIOS REQUERIDOS**

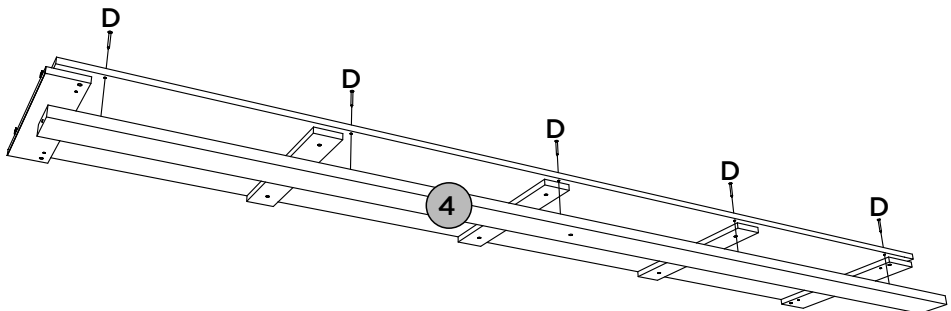
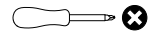
D		05
---	---	----

**FERRAMENTAS NECESSÁRIAS**

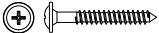
## ACESSÓRIOS REQUERIDOS

E		25
X		10

## FERRAMENTAS NECESSÁRIAS

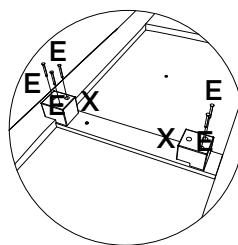
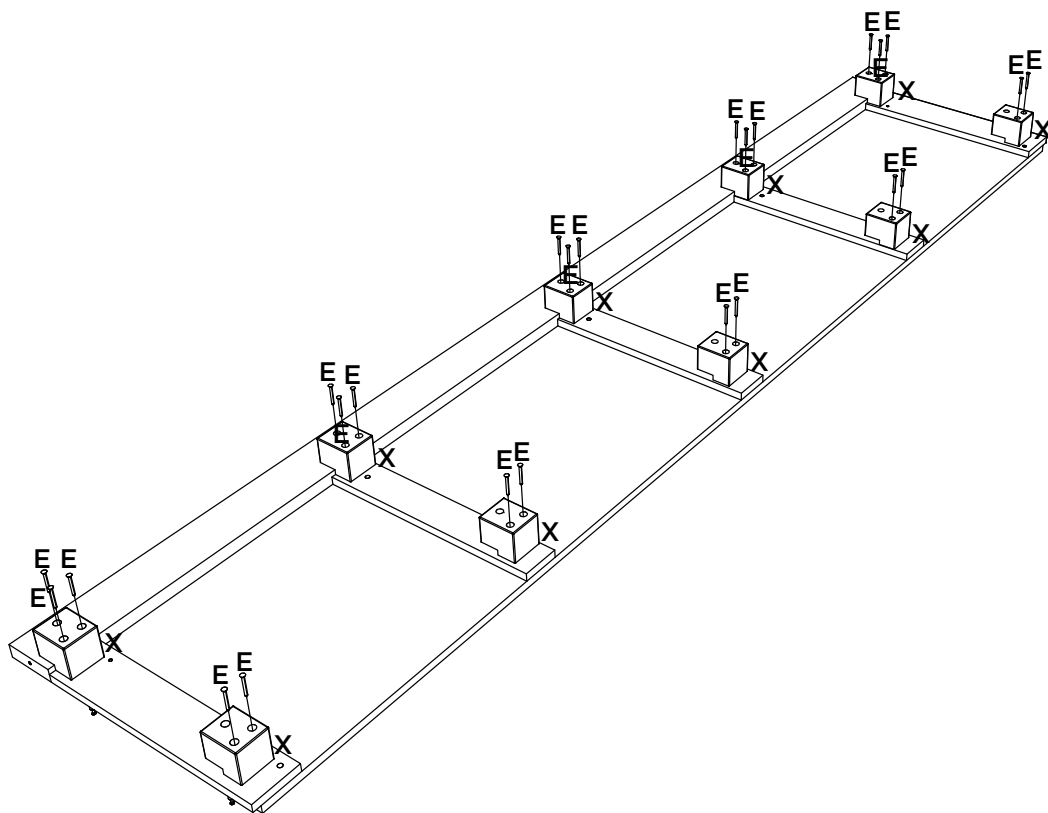
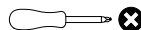

## PASSO 7

## PEÇAS REQUERIDAS

5	TAMPO DAS GAVETAS ESQUERDA	x1
6	DIVISÃO ESQUERDA MENOR	x1
7	TAMPO DAS GAVETAS DIREITA	x1
8	DIVISÃO DIREITA MENOR	x1

## ACESSÓRIOS REQUERIDOS

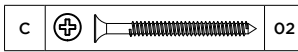



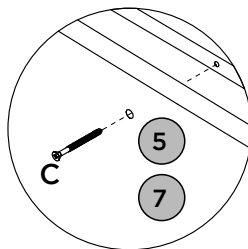
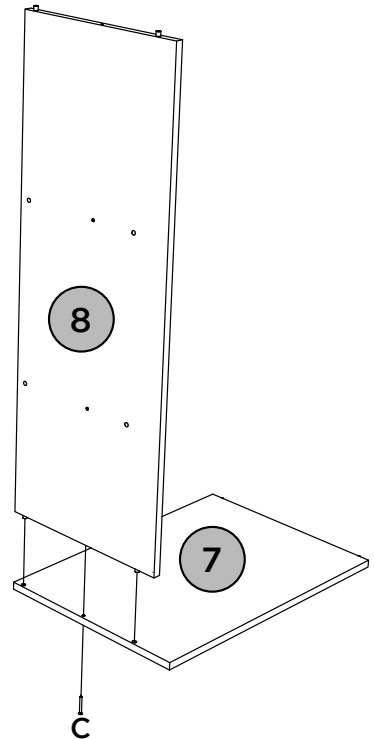
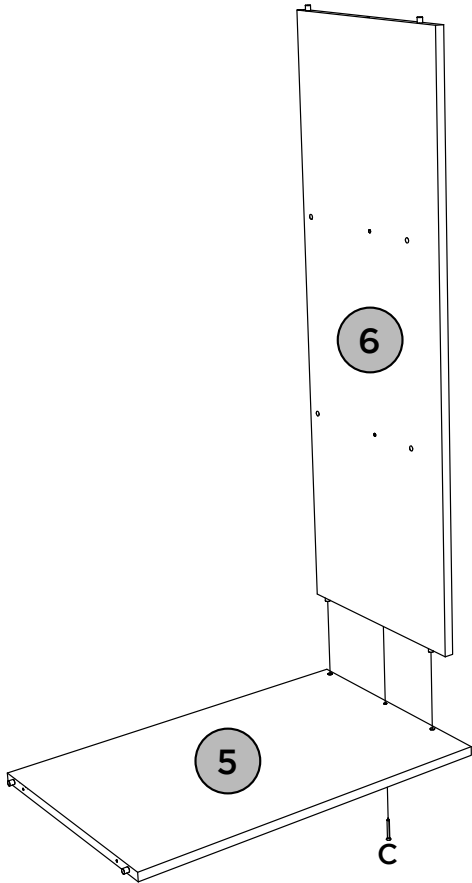
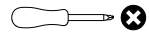

## FERRAMENTAS NECESSÁRIAS



## PEÇAS REQUERIDAS

9	LATERAL ESQUERDA	x1
10	DIVISÃO GAVETA ESQUERDA	x1
11	PRATELEIRA	x2

## ACESSÓRIOS REQUERIDOS

C		06
K		02
N		03
T		01

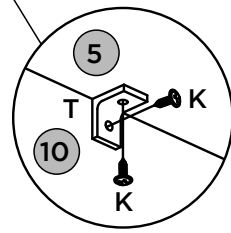
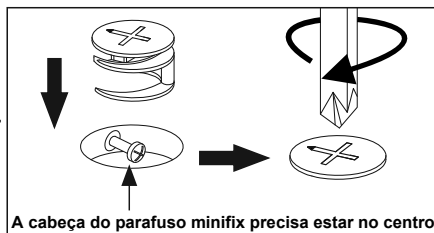
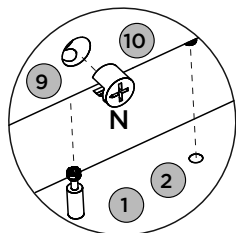
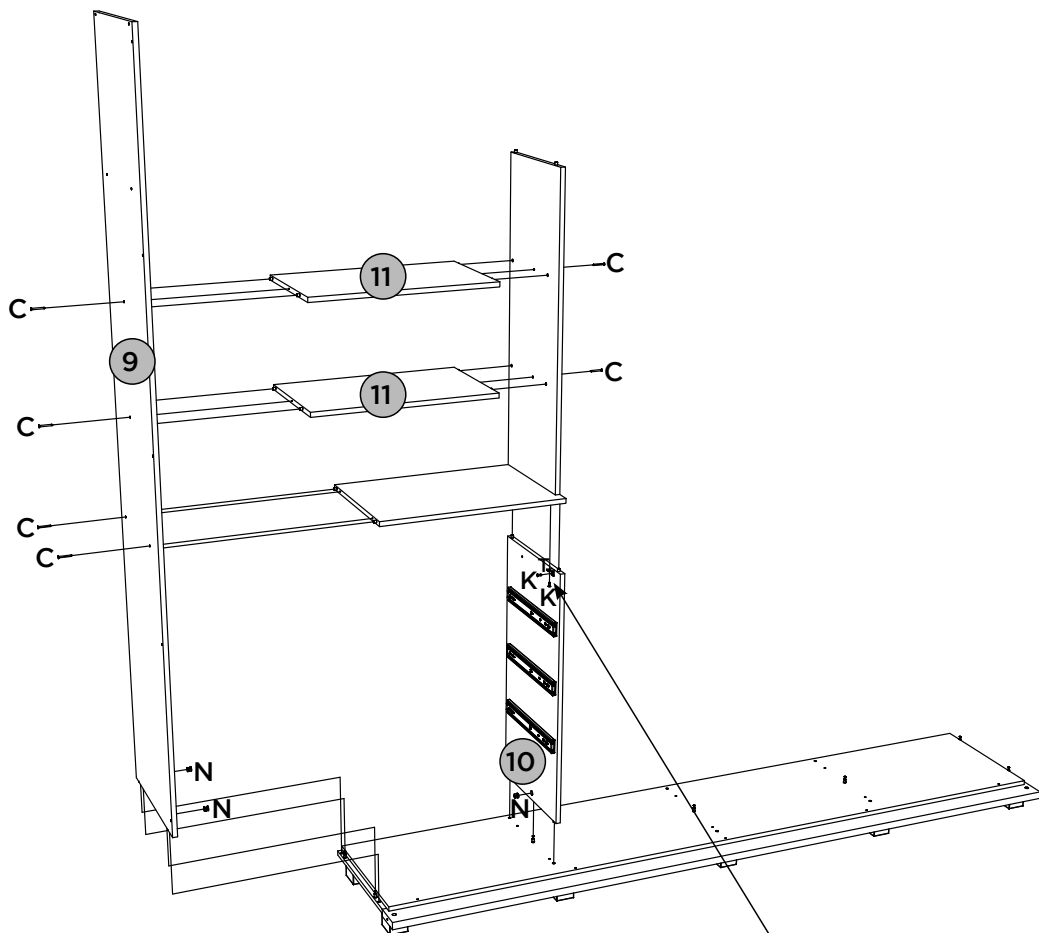

## FERRAMENTAS NECESSÁRIAS



## PEÇAS REQUERIDAS

12	DIVISÃO CENTRAL	x1
13	PRATELEIRA DO CALCEIRO	x1

## ACESSÓRIOS REQUERIDOS

C		02
N		01

## FERRAMENTAS NECESSÁRIAS

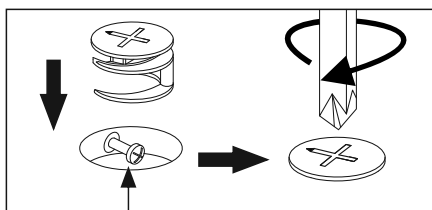
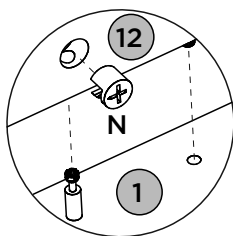
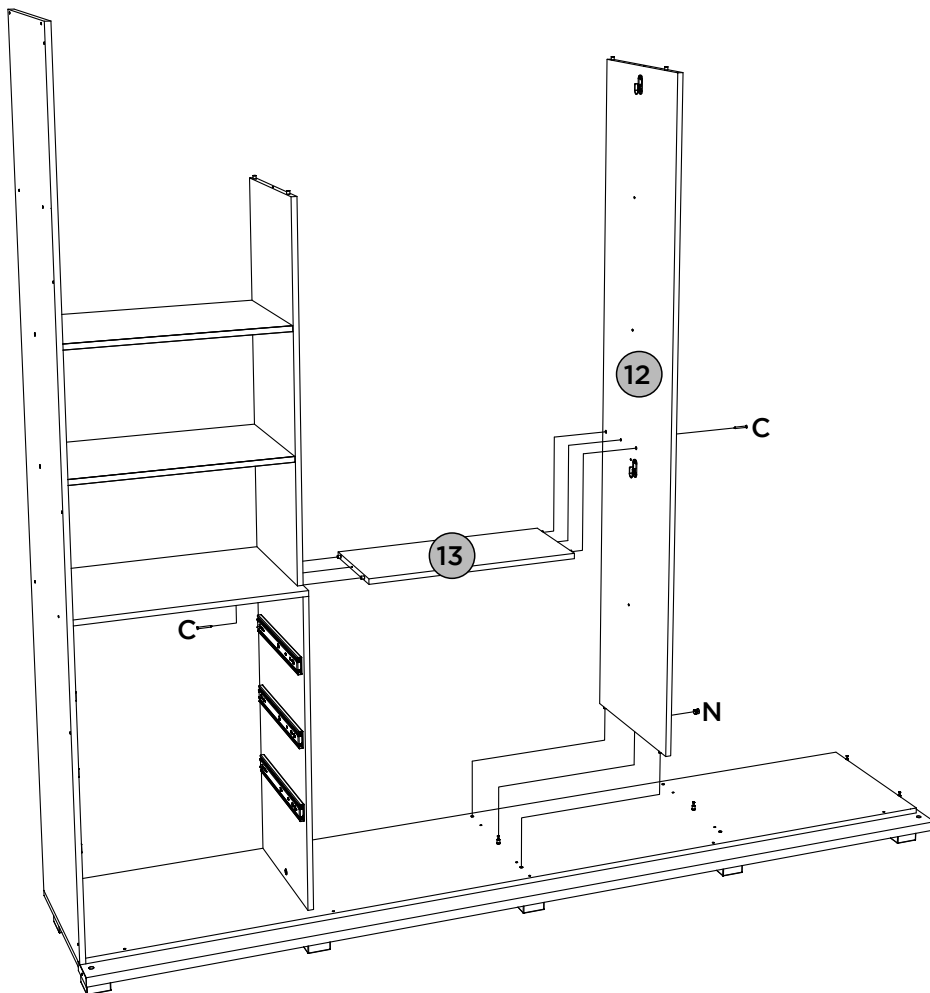
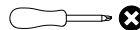





A cabeça do parafuso minifix precisa estar no centro

## PEÇAS REQUERIDAS

14	DIVISÃO GAVETA DIREITA	x1
15	PRATELEIRA	x4

## ACESSÓRIOS REQUERIDOS

C		08
K		02
N		01
T		01

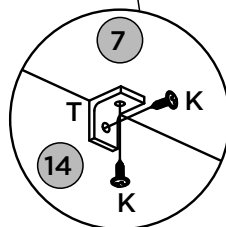
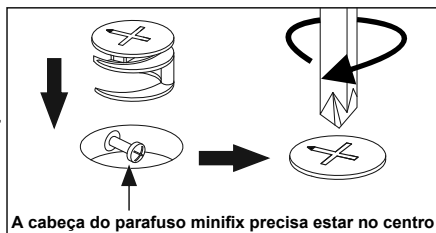
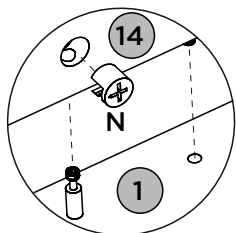
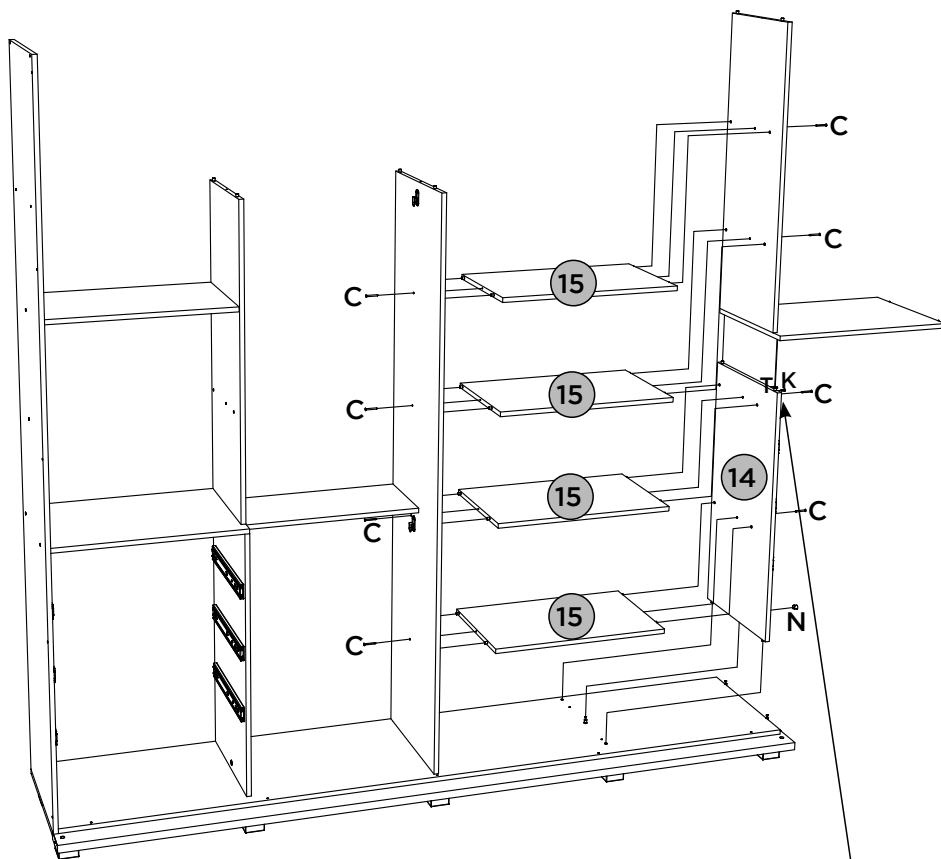
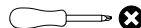

## FERRAMENTAS NECESSÁRIAS



## PEÇAS REQUERIDAS

16	CHÃO DO MALEIRO	x1
17	RIPA DO MALEIRO	x1
18	TAMPO SUPERIOR	x1
19	LATERAL DIREITA	x1

## ACESSÓRIOS REQUERIDOS

B		04
C		11
N		02

## FERRAMENTAS NECESSÁRIAS

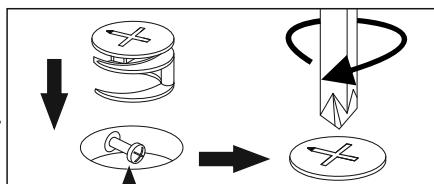
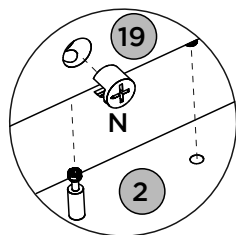
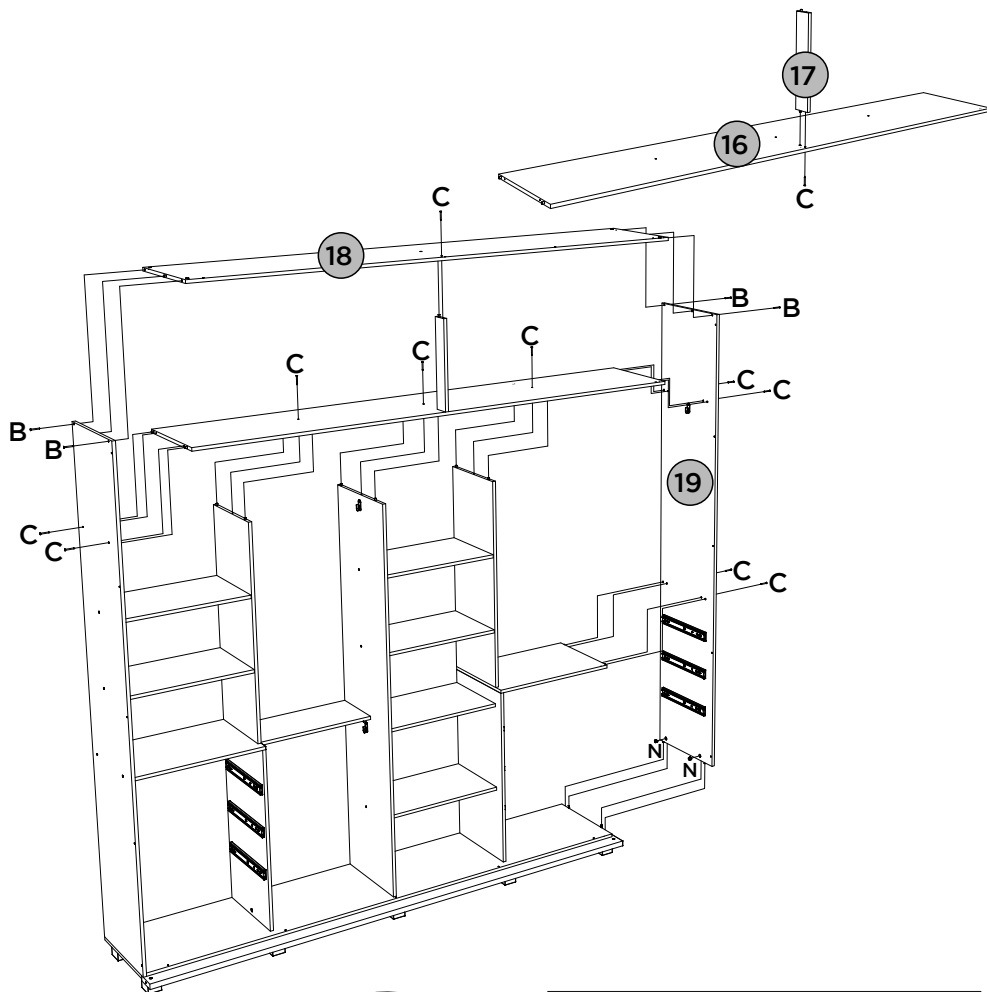
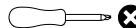



A cabeça do parafuso minifix precisa estar no centro

## PEÇAS REQUERIDAS

20	FUNDO SUPERIOR	x1
21	FUNDO	x8

## ACESSÓRIOS REQUERIDOS

O		220
P		74
AA		04

## FERRAMENTAS NECESSÁRIAS

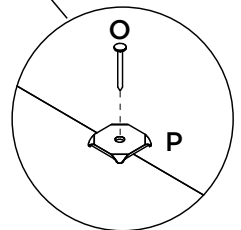
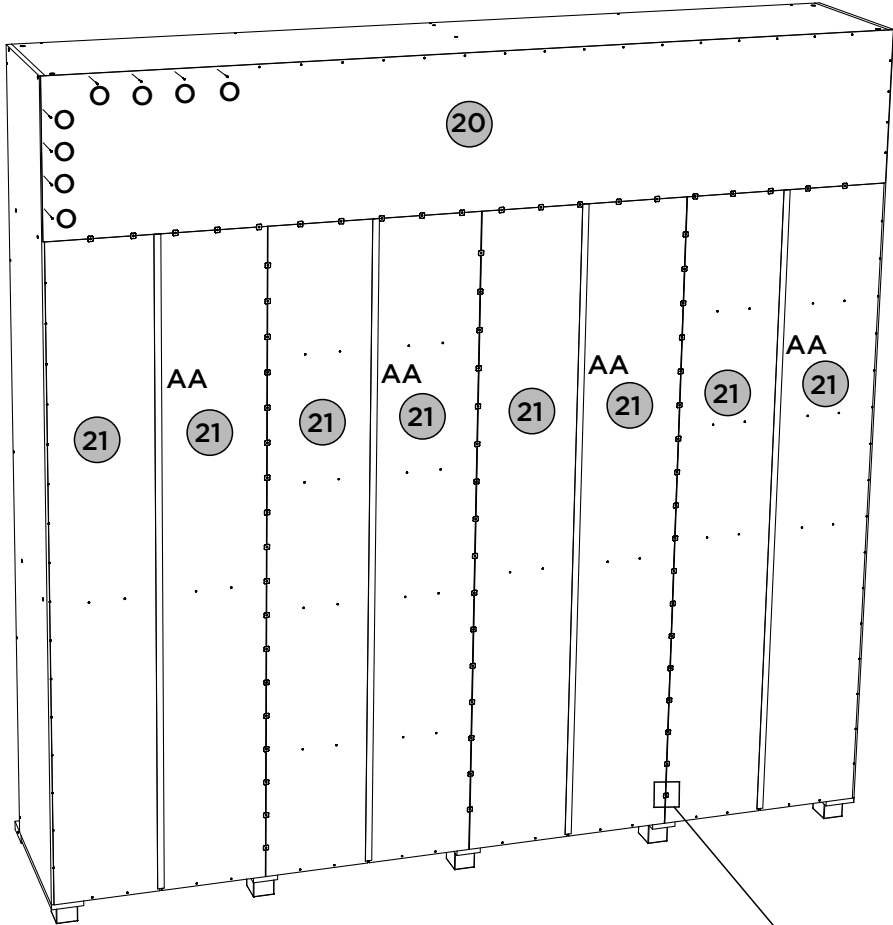









# PASSO 13

ITM/D306-

## PEÇAS REQUERIDAS

22	MOLDURA LATERAL	x2
23	MOLDURA SUPERIOR	x1

## ACESSÓRIOS REQUERIDOS

A		04
D		15
K		13
Y		03
AC		01
AD		01

## FERRAMENTAS NECESSÁRIAS

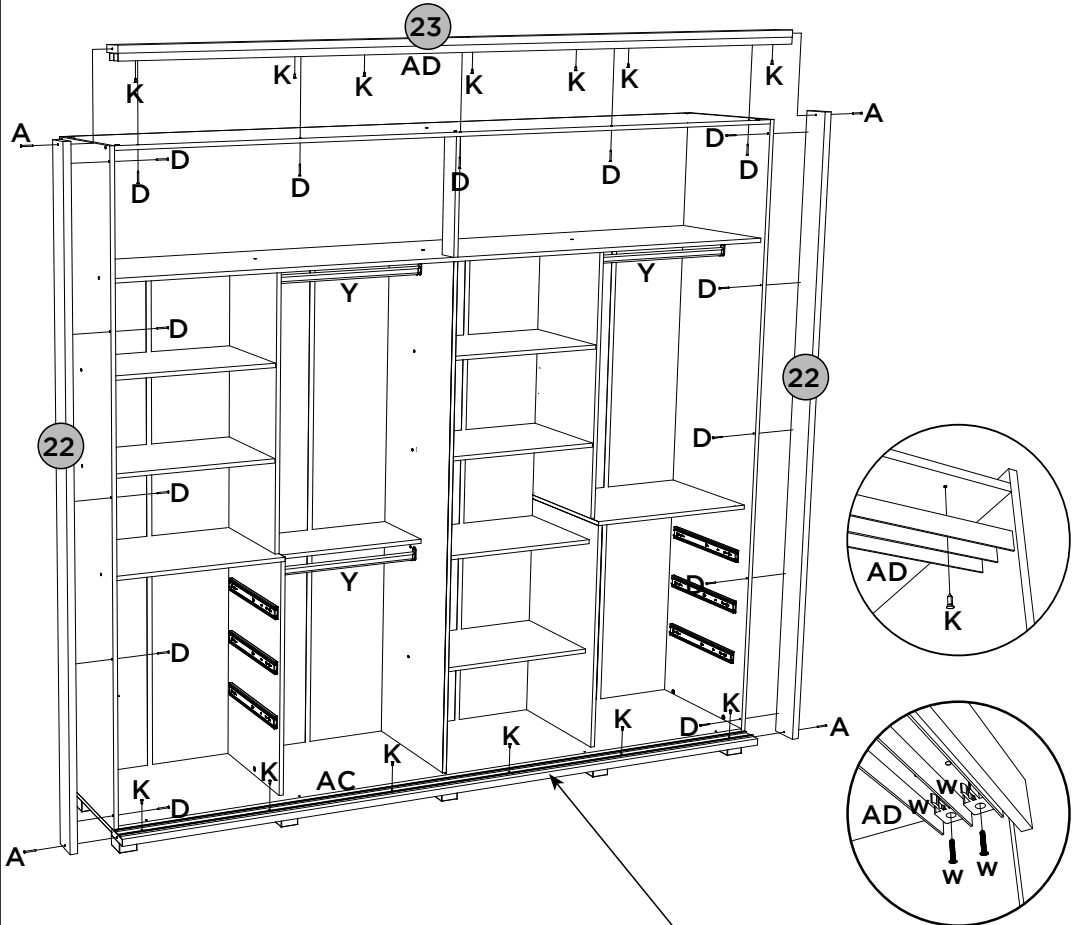
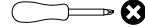

Trilho Inferior (AC) deverá ficar sobre a peça (04) e encostado na Base (01)

El Riel Inferior (AC) debe estar en la parte (04) y apoyado contra la Base (01)



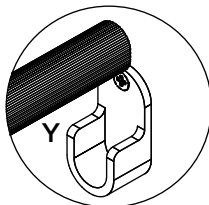

Lower Rail (AC) should be on the part (04) and leaning against the Base (01)



**PEÇAS REQUERIDAS**

24	PAINEL INFERIOR SUPERIOR	x2
25	PAINEL	x3
27	PAINEL ESPELHO	x1
29	PAINEL DIREITO MENOR	x1

**ACESSÓRIOS REQUERIDOS**

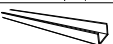
H		28
K		32
U		16
W		01
AB		04

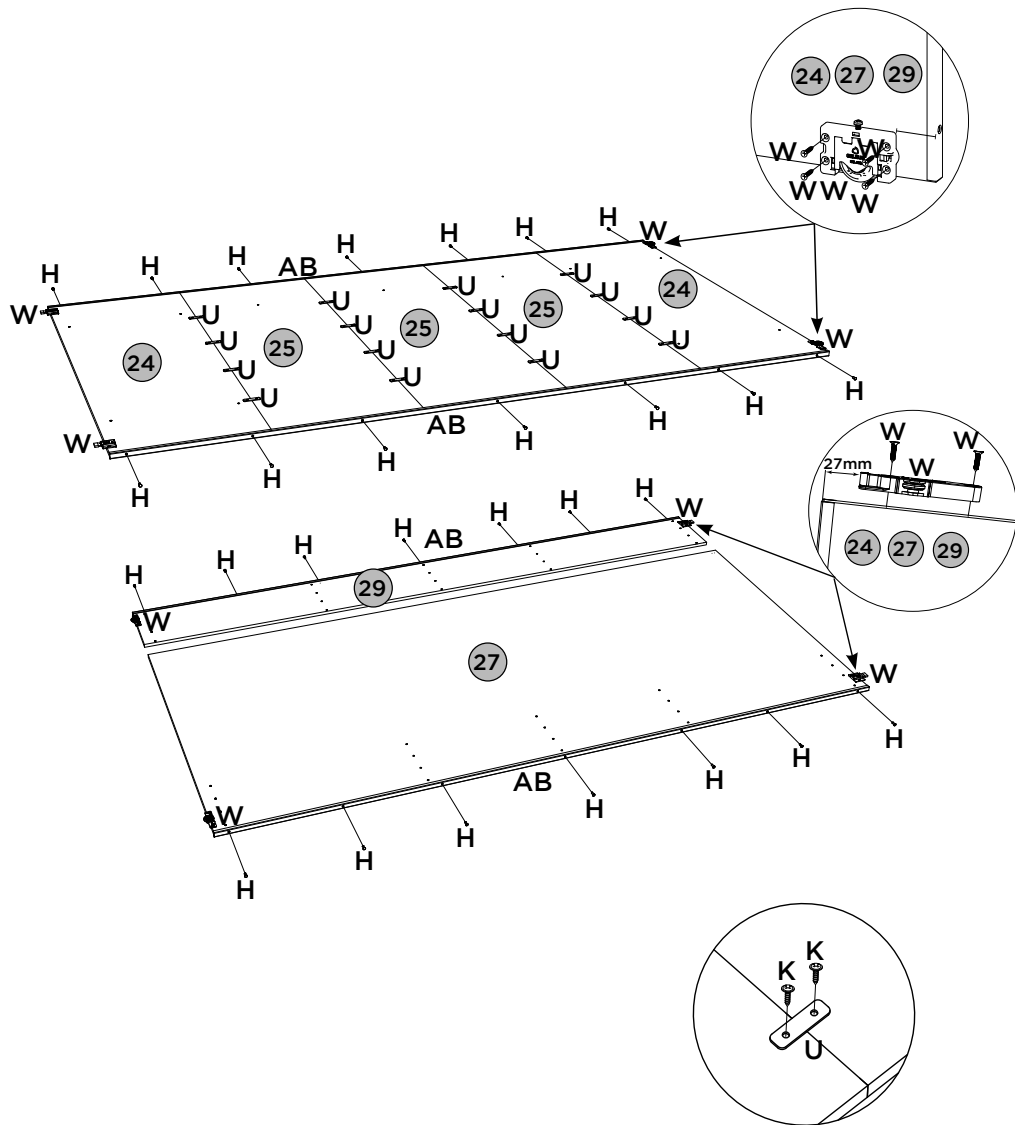
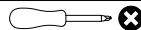
**FERRAMENTAS NECESSÁRIAS**

**PEÇAS REQUERIDAS**

24	PAINEL INFERIOR SUPERIOR	x2
25	PAINEL	x3
26	APLIQUE	x1
27	PAINEL ESPELHO	x1
29	PAINEL DIREITO MENOR	x1
30	APLIQUE	x8

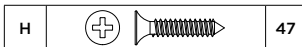
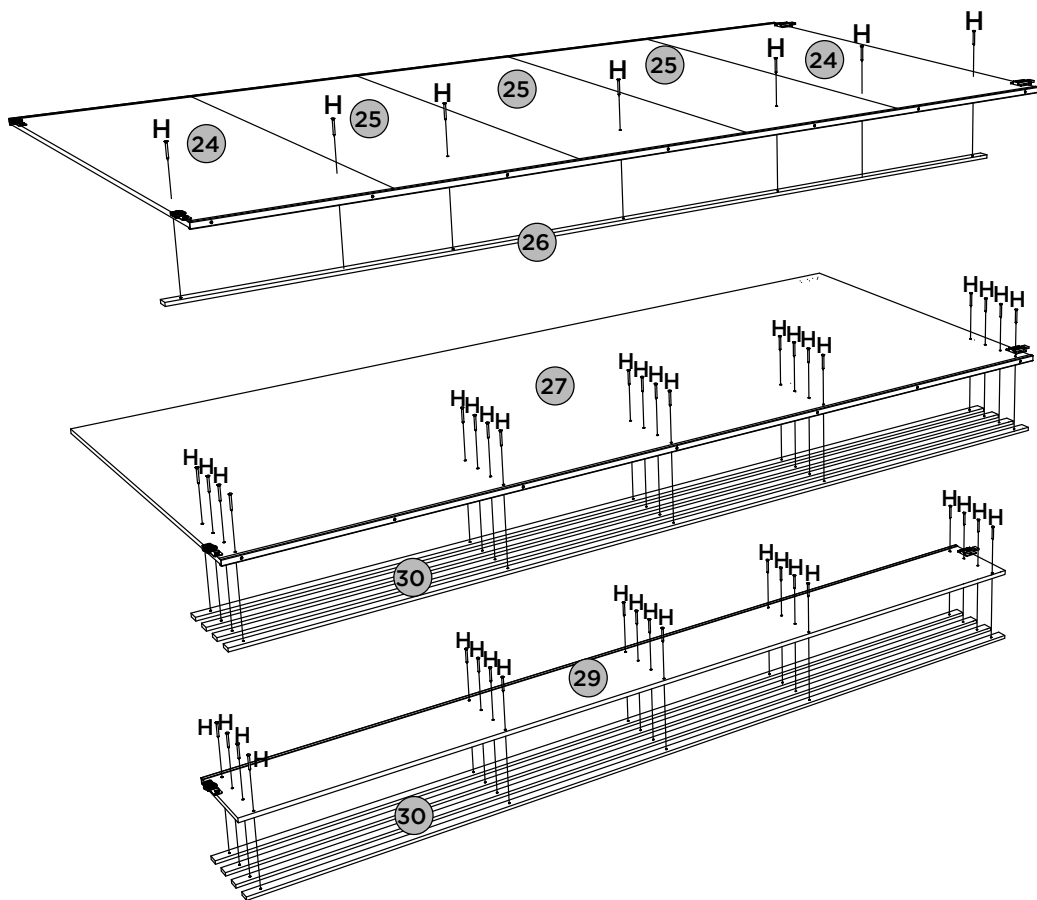
**ACESSÓRIOS REQUERIDOS**

**FERRAMENTAS NECESSÁRIAS**





# PASSO 16

ITM/D306-

## PEÇAS REQUERIDAS

28	ESPELHO	x2
31	TRAVESSA DA PORTA	x1

## ACESSÓRIOS REQUERIDOS

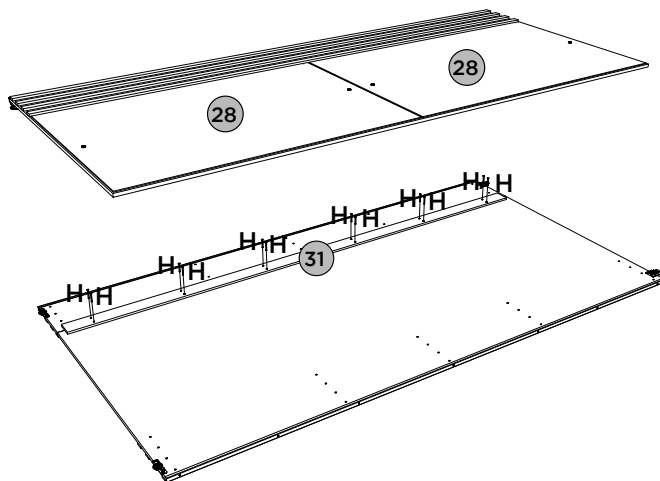
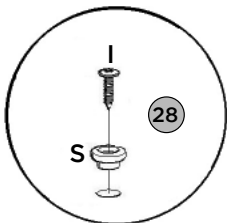

H		12
I		04
S		04

## FERRAMENTAS NECESSÁRIAS



# PASSO 17

## ACESSÓRIOS REQUERIDOS

AE		16
AI		28

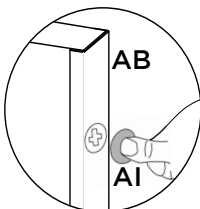
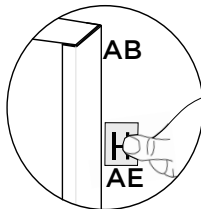

Para a colocação das portas nos trilhos encaixe primeira a porta no trilho superior (AD) e em seguida no trilho de alumínio inferior (AC).

Para la colocación de las puertas en la pista instalación de la puerta en la primera banda superior (AD) y luego el riel de aluminio inferior (AC).

For placing the doors on the rails fitting the door on the rail first (AD) and then on the lower aluminum rail (AC).

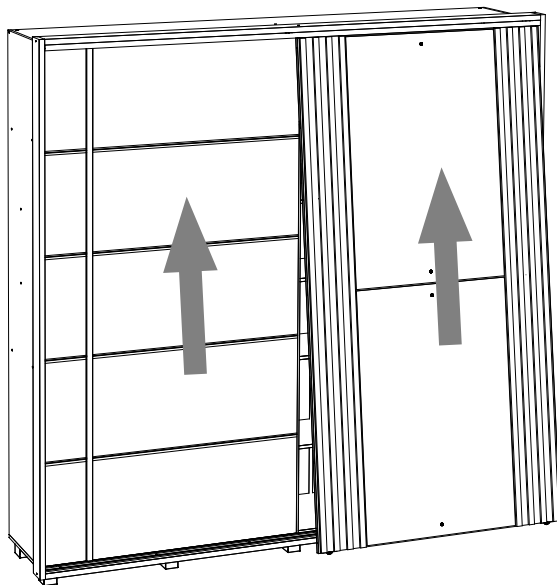



# PASSO 18

ITM/D306-

## PEÇAS REQUERIDAS

33	LADO DE GAVETA	x12
----	----------------	-----

## ACESSÓRIOS REQUERIDOS

L		48
AF		

## FERRAMENTAS NECESSÁRIAS

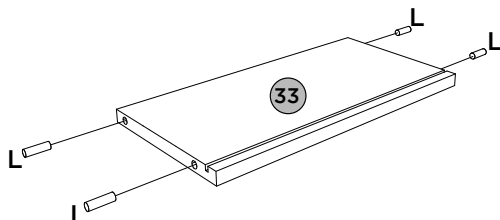



# PASSO 19

## PEÇAS REQUERIDAS

32	RIPA DE TRÁS	x6
33	LADO DE GAVETA	x12
34	FUNDO DE GAVETA RECORTADO	x6

## ACESSÓRIOS REQUERIDOS

F		24
AF		

## FERRAMENTAS NECESSÁRIAS

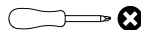

**6x**

1º

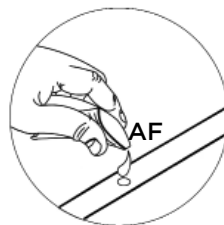
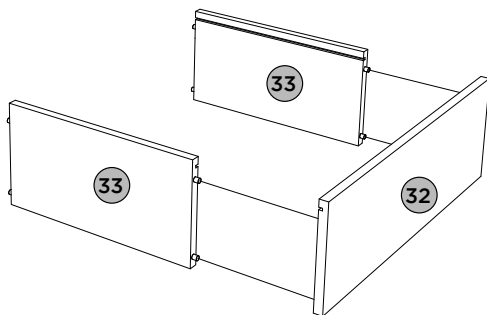

**6x**



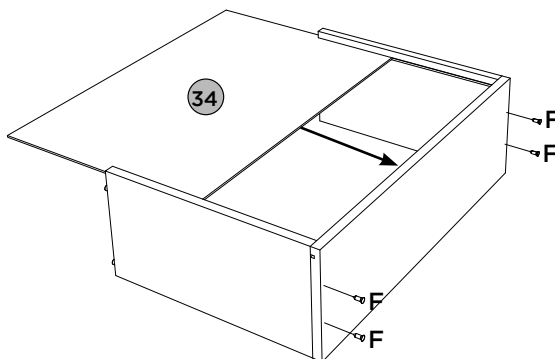
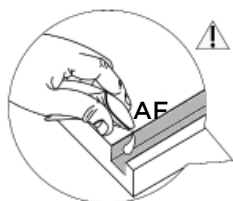

2º



**PEÇAS REQUERIDAS**



35	FRENTE DE GAVETA	x6
----	------------------	----

**ACESSÓRIOS REQUERIDOS**

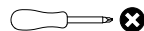
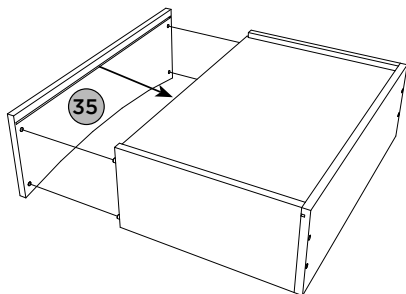
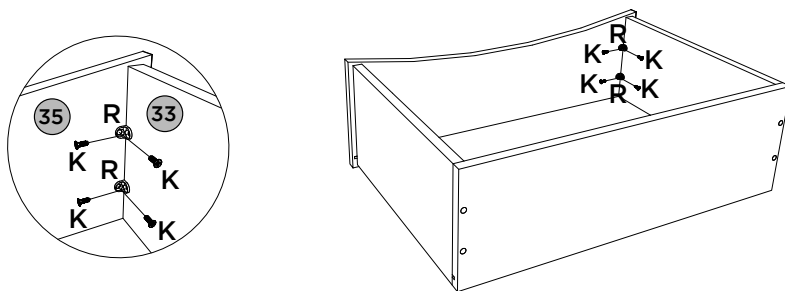
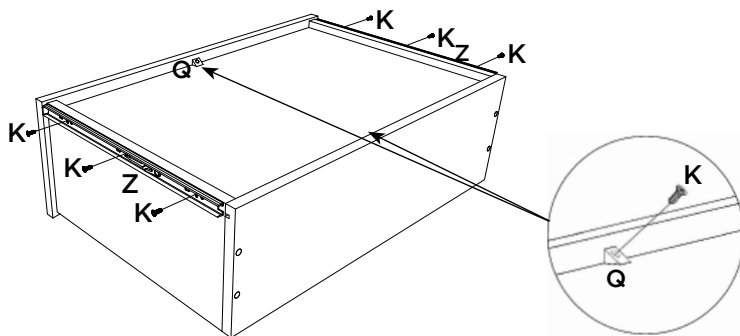
K		96
Q		12
R		24
Z		06
AF		

**FERRAMENTAS NECESSÁRIAS**

**6x**
**3º**

**6x**
**4º**

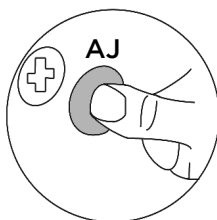
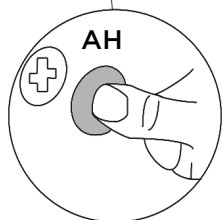
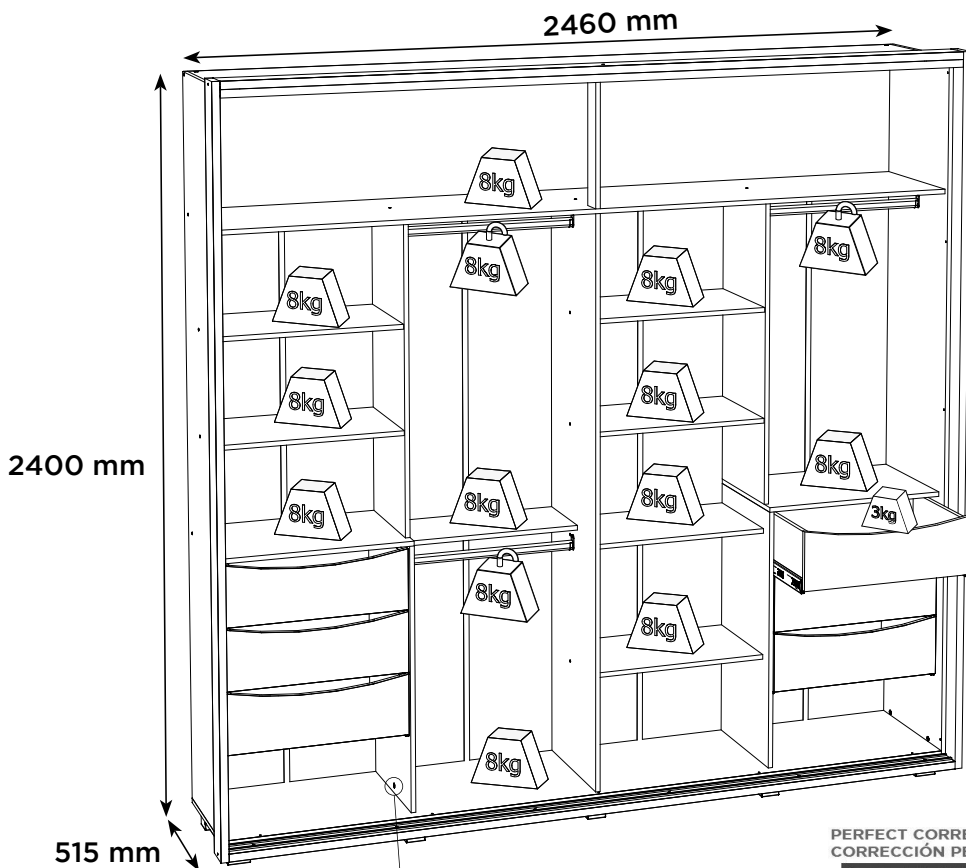
**6x**
**5º**

ACESSÓRIOS REQUERIDOS

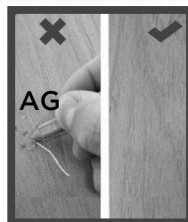
AG		02
AH		08
AJ		52
AK	<b>HENN</b>	01



PERFECT CORRECTION  
CORRECCIÓN PERFECTA



Pesos máximos recomendados con carga distribuída  
 Peso máximo recomendado con la carga distribuída  
 Recommended maximum weight with distributed load.

**Produto Concluído**  
**Producto terminado**  
**Finished Product**

