

Item	Caixa Caja Box	Qtd Ctd Qty	Descrição Descripción Description	Medidas (mm)   Dimensions (mm)   Size (measurements) (mm)
01	2/3	01	Rodapé Frontal   Rodapié Frontal   Front baseboard	2076x73x12
02	2/3	02	Travessa do rodapé   Carril pie   Baseboard crosspiece	415x73x12
03	2/3	01	Rodapé Traseiro   Rodapié trasero   Rear baseboard	2076x73x12
04	2/3	01	Base   Base   Base	2076x445x12
05	1/3	01	Lateral esquerda   Lateral izquierda   Left side	2250x445x15
06	1/3	01	Divisão esquerda   División de la izquierda   Left Division	1658x445x12
07	2/3	01	Prateleira do Calceiro   Estantería Calceiro   Shelf Calceiro	684x250x12
08	1/3	01	Divisão direita   División derecha   Right Division	1658x445x12
09	2/3	01	Tampo das Gavetas   Tapa de los cajones   Drawer Top	684x400x12
10=14	2/3	02	Prateleira   Estante   Shelf	684x350x12
11	2/3	02	Ripa do maleiro   Portaequipajes de ripa   Lath of the closet top shelf	414x73x12
12	2/3	01	Chão do maleiro   Piso del portaequipajes   Floor of the luggage rack	2076x445x12
13	1/3	01	Lateral direita   Lateral derecha   Right side	2250x445x15
14=10	2/3	03	Prateleira   Estante   Shelf	684x350x12
15	2/3	01	Tampo   Tapa   Top	2076x445x12
16	1/3	01	Chapéu   Sombrero   Hat	2104x73x15
17	1/3	01	Fundo Superior   Fondo Superior   Superior background	2100x431x3
18	1/3	06	Fundo   Fondo   Bottom	1675x346x3
19	3/3	02	Porta Espelho   Puerta Espejo   Mirror Door	2092x345x15
20	3/3	02	Espelho   Espejo   Mirror	1250x300x3
21	3/3	04	Porta Lateral   Puerta lateral   Side door	2092x345x15
22	2/3	03	Frente de gaveta   Frente de cajón   Front of drawer	626x145x15
23	2/3	06	Lado de gaveta   Lado del cajón   Side of drawer	350x110x12
24	2/3	03	Fundo de gaveta recortado   Fondo de cajón recortado   Drawer bottom trimmed	596x361x3
25	2/3	03	Ripa de trás   Malla detrás   Rear lath	609x110x12

# HENN

Ind. e Com. de Móveis Henn  
Mondai - SC - Brasil

+55 49 3674.3500

@moveishenn  
www.henn.com.br

## INSTRUÇÕES DE MONTAGEM

INSTRUCCIONES DE MONTAJE  
ASSEMBLY INSTRUCTIONS

### Roupeiro Flora 06 Portas | Armario Flora 06 Puertas | Wardrobe Flora 06 doors

- c D215-09 Café/Branco
- c D215-35 Duna/Cristal
- c D215-106 Rústico/OFF White

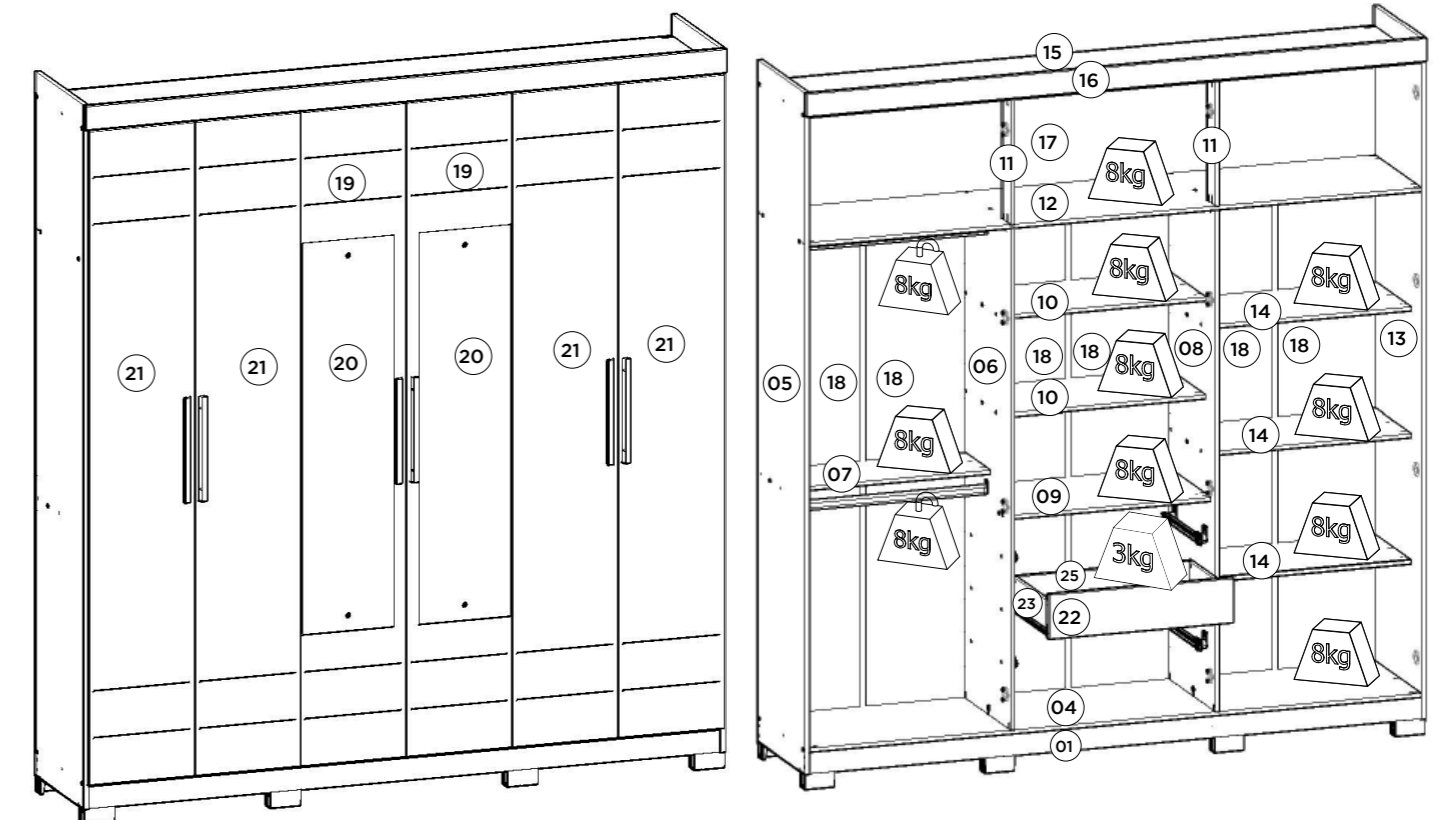

**Pesos máximos recomendados com carga distribuída** Peso máximo recomendado con la carga distribuida  
**Recommended maximum weights with evenly distributed.**

**AVISO**  
Para limpeza de seu móvel, use uma flanela seca ou umedecida, e não utilize produtos químicos que possam danificar seu produto.

**SISTEMA DE MONTAGEM**  
O sistema de montagem dos produtos, funciona de acordo com a ordem crescente dos números indicados no desenho. Ex: 01, 02, 03, 04... até a conclusão da montagem.

**ASSISTÊNCIA TÉCNICA**  
Para solicitação de Assistência Técnica você consumidor deverá entrar em contato com o Lojista o qual você realizou a compra deste produto e solicitar a assistência técnica das peças avariadas. A garantia abrange todas as peças, partes e componentes que eventualmente venham apresentar defeito de fabricação no prazo de 03 (três) meses, contando a partir da entrega do produto ao consumidor, mediante nota fiscal de compra. Se houver qualquer alteração na estrutura do produto ou ocorrer defeito por negligência do montador/consumidor em relação a instrução de montagem e manuseio, não será fornecido assistência técnica gratuita.

**ADVERTENCIA**  
Para limpieza de su móvil, use una flanela seca o húmeda, y no utilice productos químicos que puedan dañar su producto.

**SISTEMA DE MONTAJE**  
El sistema de montaje de los productos funciona de acuerdo con el orden creciente de los números indicados en el dibujo. Ej.: 01, 02, 03, 04... hasta la conclusión del montaje.

**ASISTENCIA TÉCNICA**  
Para solicitar Asistencia Técnica, el consumidor debe comunicarse con el Comercio que usted realizó la compra de este producto y solicita asistencia técnica para las partes dañadas. La garantía cubre todas las partes, piezas y componentes que eventualmente puedan presentar defecto de fabricación en el plazo de 03 (tres) meses, contados a partir de la entrega del producto al consumidor, mediante factura de compra. Si se produce algún cambio en la estructura del producto o se produce un defecto por negligencia del montador/consumidor en relación con las instrucciones de montaje y manipulación, no se prestará asistencia técnica gratuita.

**NOTICE**  
To clean your furniture, use a dry or wet cloth, and do not use chemicals that may damage your product.

**ASSEMBLY SYSTEM**  
The products' assembly system works according to the increasing order of the indicated numbers. For example: 01, 02, 03, 04 ... to the end of the assembly.

**TECHNICAL ASSISTANCE**  
To request Technical Assistance, the consumer must contact the retailer from whom you purchased this product and request technical assistance for the damaged parts. The warranty covers all parts, parts and components that may eventually present a manufacturing defect within a period of 03 (three) months, counting from the delivery of the product to the consumer, by means of a purchase invoice. If there is any change in the structure of the product or defect occurs due to negligence of the assembler/consumer in relation to the assembly and handling instruction, free technical assistance will not be provided.

#### Requisitos para montagem Requisitor para la montaje Assembly Requirements

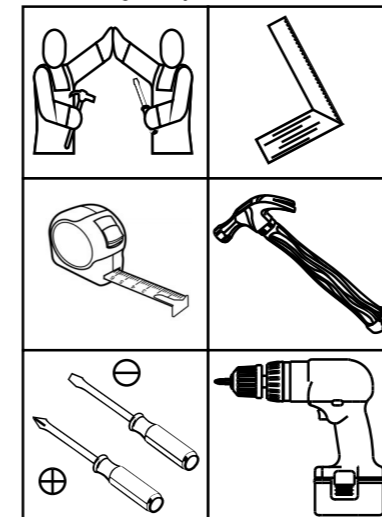

Imagens meramente ilustrativas  
Imágenes meramente ilustrativas  
Images for illustration only

#### Ferragens | Herrajes | Hardware

<b>A</b> Parafuso 4,5x50mm CHT. Tornillo 4,5x50mm CHT. Screw 4,5x50mm CHT.	<b>B</b> Parafuso 3,5x40mm CHT. Tornillo 3,5x40mm CHT. Screw 3,5x40mm CHT.	<b>C</b> Parafuso 4,0x22mm FLA. Tornillo 4,0x22mm FLA. Screw 4,0x22mm FLA.	<b>D</b> Parafuso 3,5x25mm FLA. Tornillo 3,5x25mm FLA. Screw 3,5x25mm FLA.	<b>E</b> Parafuso 3,5x12mm FLA. Tornillo 3,5x12mm FLA. Screw 3,5x12mm FLA.	<b>F</b> Parafuso 3,5x12mm CHT. Tornillo 3,5x12mm CHT. Screw 3,5x12mm CHT.	<b>G</b> Parafuso 3,0x16mm CHT. Tornillo 3,0x16mm CHT. Screw 3,0x16mm CHT.	<b>H</b> Cavilha 5x25mm Cinta 5x25mm Dowel 5x25mm
<b>I</b> Prego 12x12mm Anelado Clavo 12x12mm Anillado Ringed Nails 12x12mm	<b>J</b> Prego 10x10mm Clavo 10x10mm Nail 10x10mm	<b>K</b> Fixador de Fundos Fund Fixer Bottom fixer	<b>L</b> Cantoneira plástica Cantонера plástica Plastic angle brackets	<b>M</b> Parafuso minifix Tornillo minifix Minifix bolt	<b>N</b> Tambor minifix Tambor minifix Minifix drum	<b>O</b> Porca cilíndrica Tuercas cilíndricas Cylindrical nut	<b>P</b> Pé "U" 50x40x100mm Pie "U" 50x40x100mm 50x40x100mm "U" feet
<b>Q</b> Porca sextavada Tuercas hexagonales Hexagon nut	<b>R</b> Cantoneira suporte triangular Cantонера soporte triangular Triangle support angle	<b>S</b> Distanciador de corredeira Distanciador de deslizamiento Sliding spacer	<b>T</b> Suporte cabideiro Soporte de percha Coat hanger support	<b>U</b> Cabideiro Alum. 676mm Alu 676mm percha Alu coat hanger 676mm	<b>V</b> Perfil "H" 1673mm Perfil "H" 1673mm Profile "H" 1673mm	<b>W</b> Etiqueta resinada Henn Etiqueta resinada Henn Henn resin label	<b>X</b> Corredeira metal 350mm Corredera de metal 350mm Sliding metal 350mm
<b>Y</b> Calço metal 5mm Calzado metálico 5mm 5 mm metal shim	<b>Z</b> Dobradilha metal 26mm Bisagra de metal 26mm 26 mm metal hinge	<b>AA</b> Perfil Puxador Revestido MDF 330mm Perfil Tirador Revestido MDF 330mm Profile MDF 330mm Coated Handle	<b>AB</b> Sachê de cola Bolsa de pegamento Glue bag	<b>AC</b> Giz de correção Tiza de corrección Chalk of correction	<b>AD</b> Adesivo tapa parafuso 17mm Adhesivo tapón de tornillo 17mm Bolt cover adhesive 17mm	<b>AE</b> Adesivo tapa parafuso 10mm Adhesivo tapón de tornillo 10mm Bolt cover adhesive 10mm	

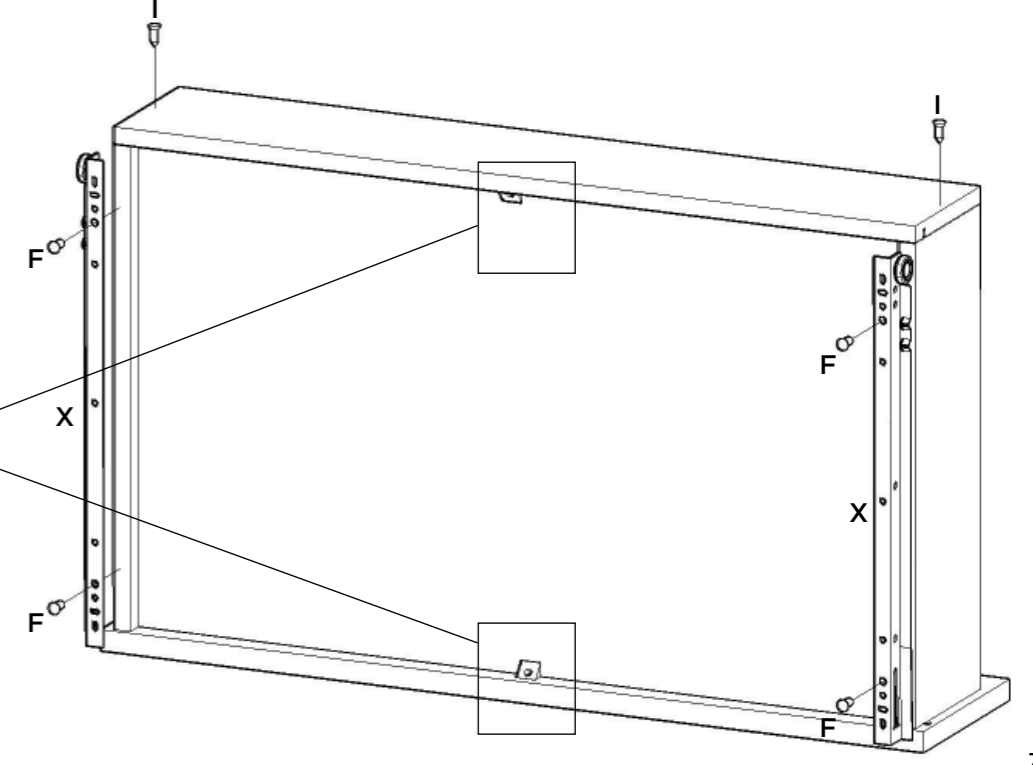
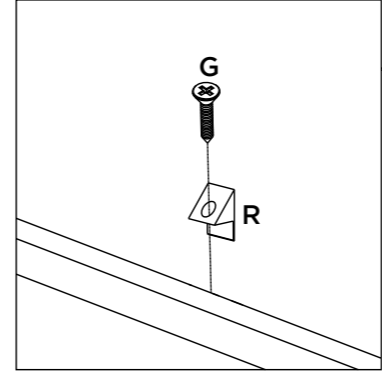
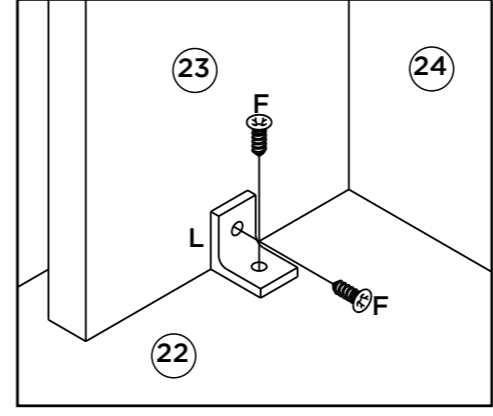
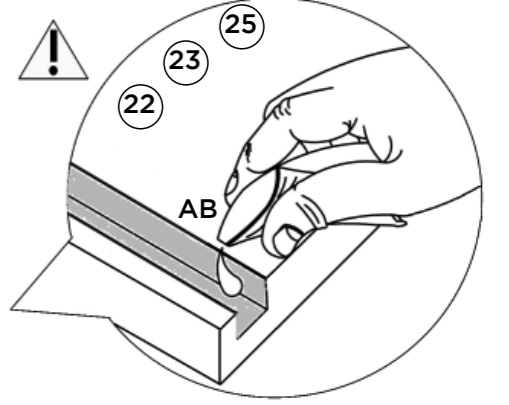
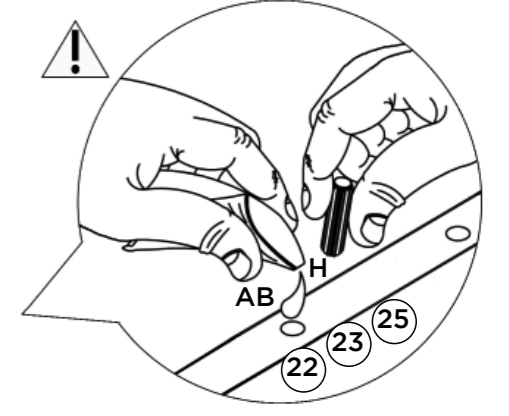
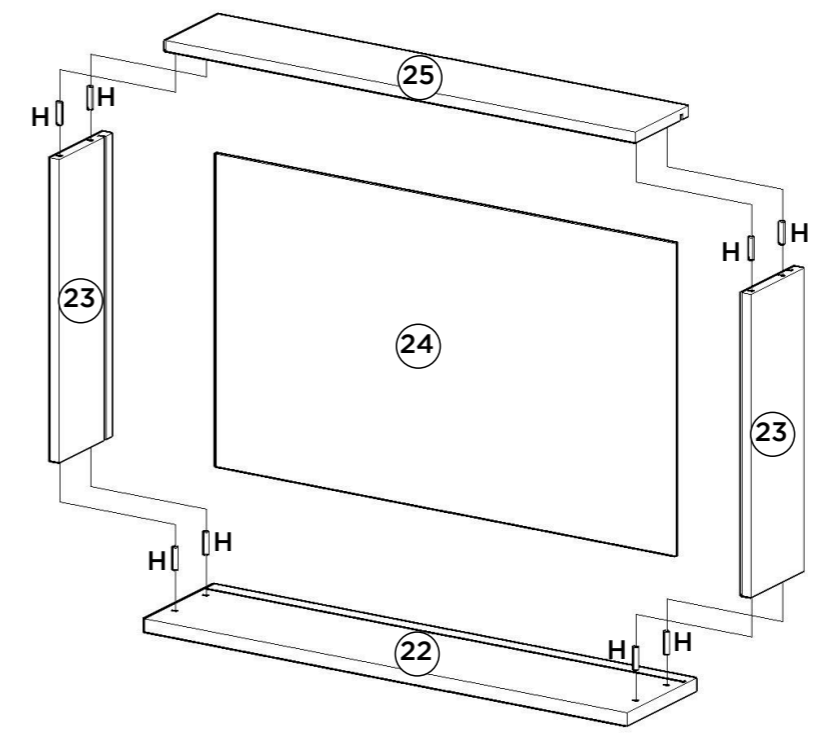
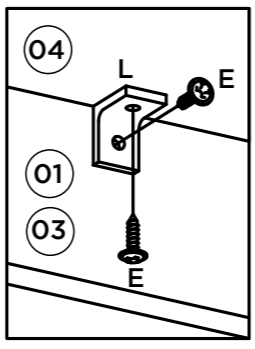
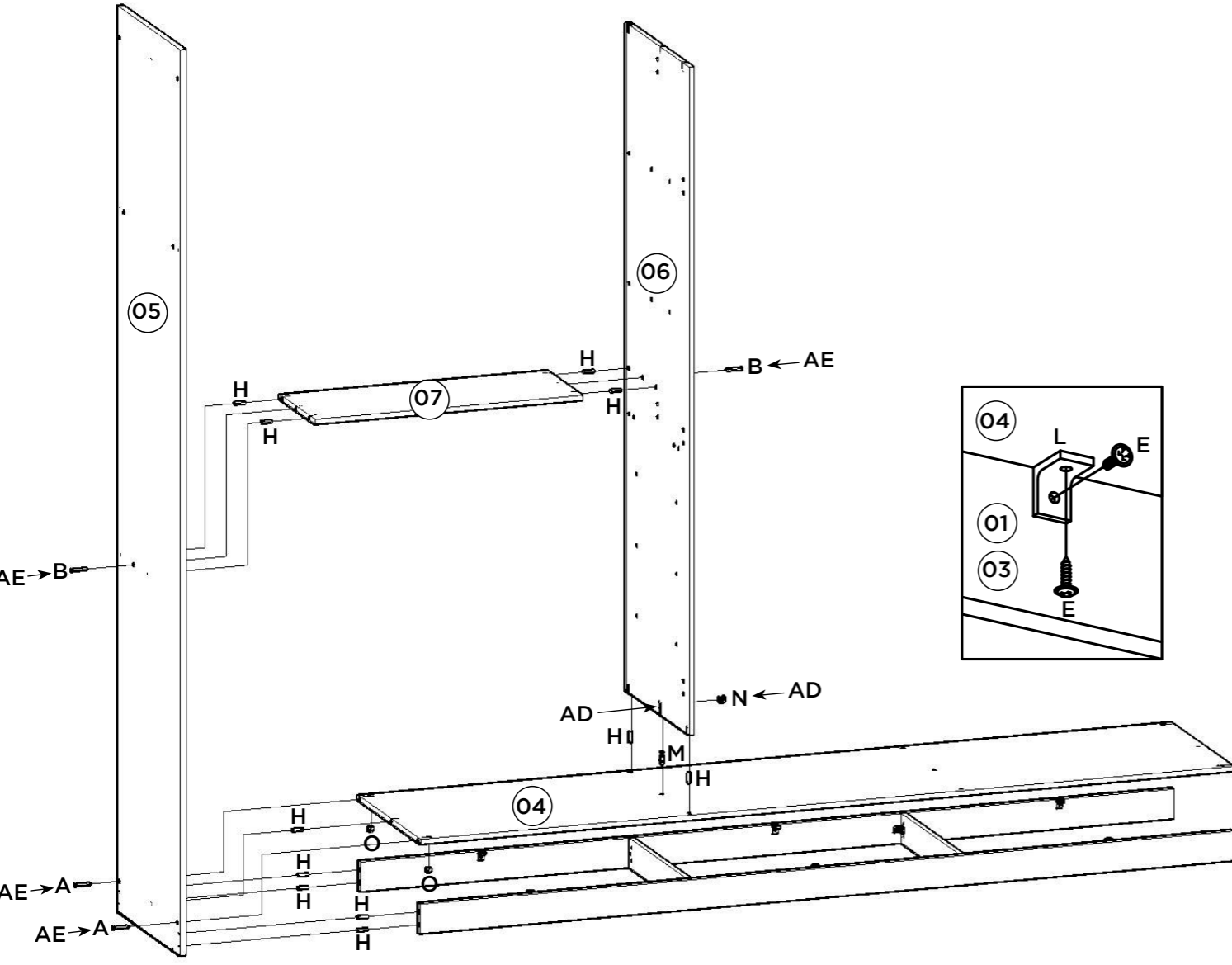
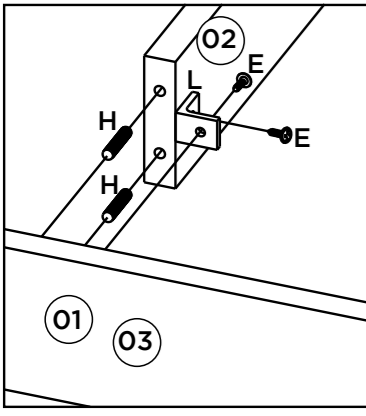
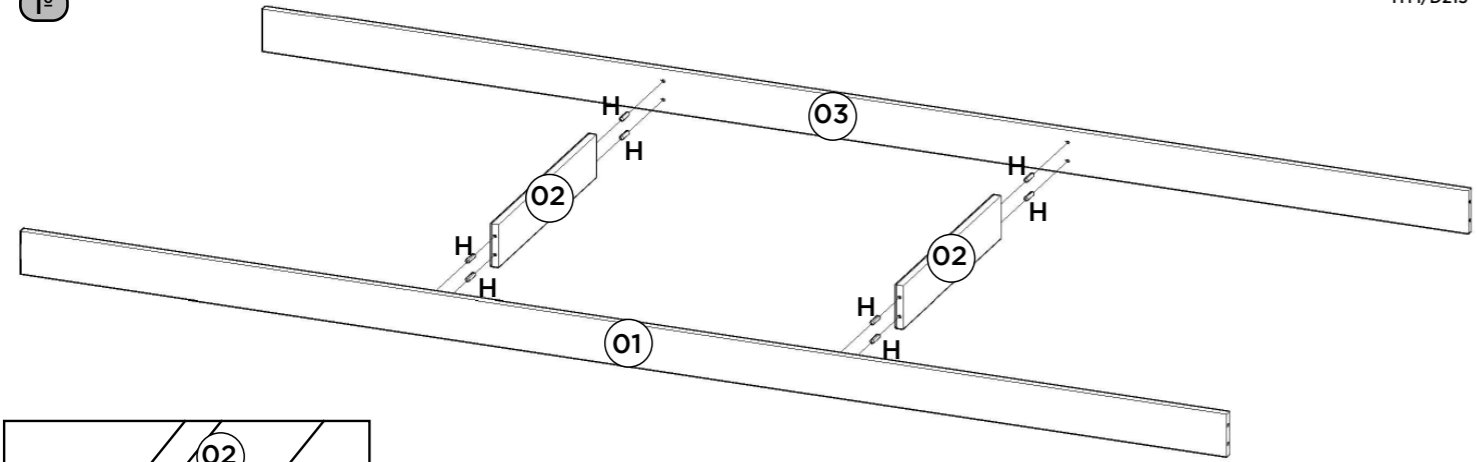

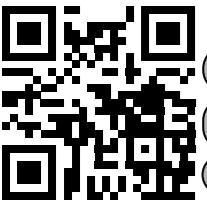
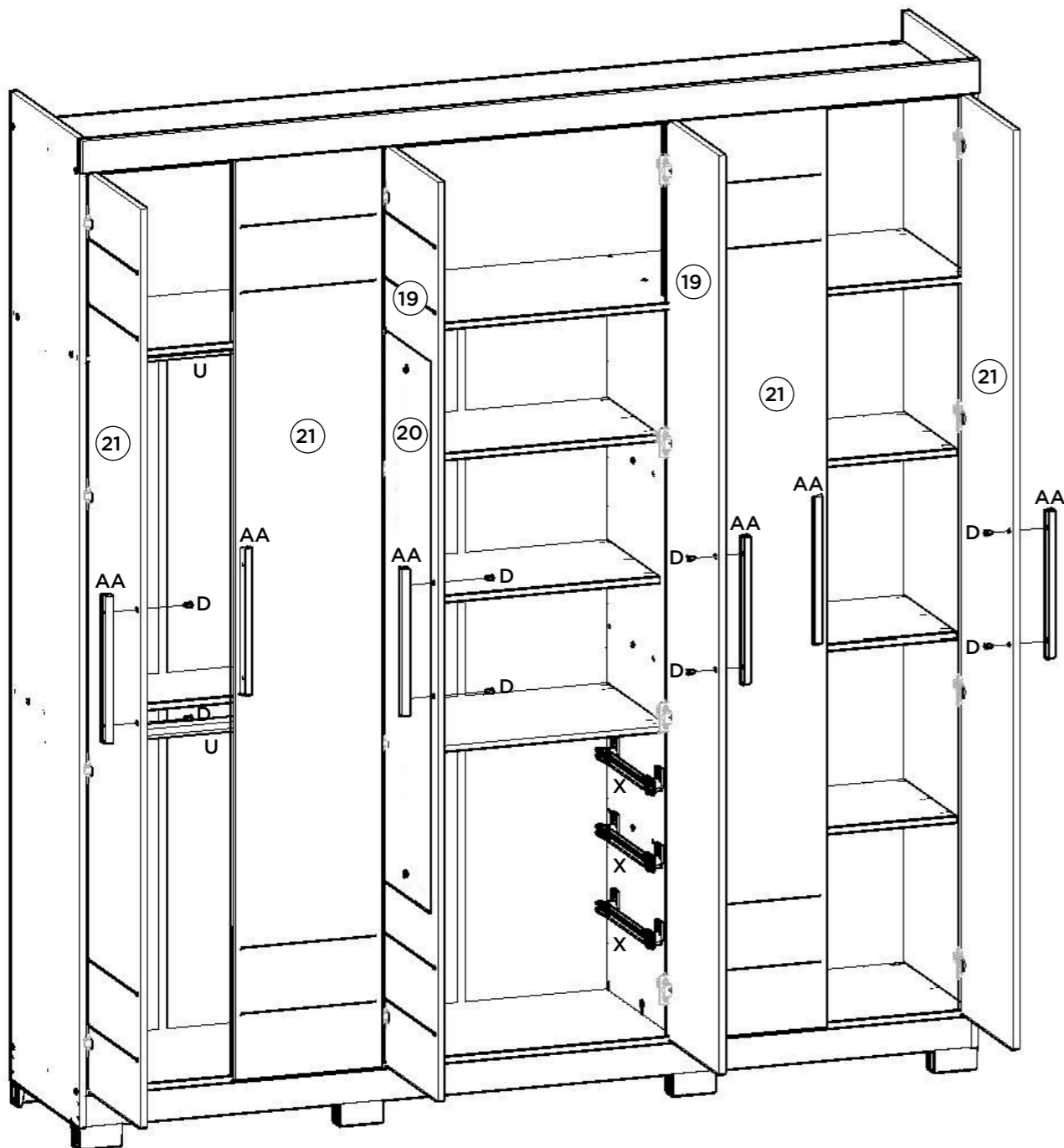

Vídeo: Dicas para instalar corredeira  
 Vídeo: consejos para instalar la diapositiva  
 Video: Tips for installing slide

Vídeo: Instalar e regular Dobradiças  
 Vídeo: Instale y ajuste las bisagras  
 Video: Install and adjust hinges

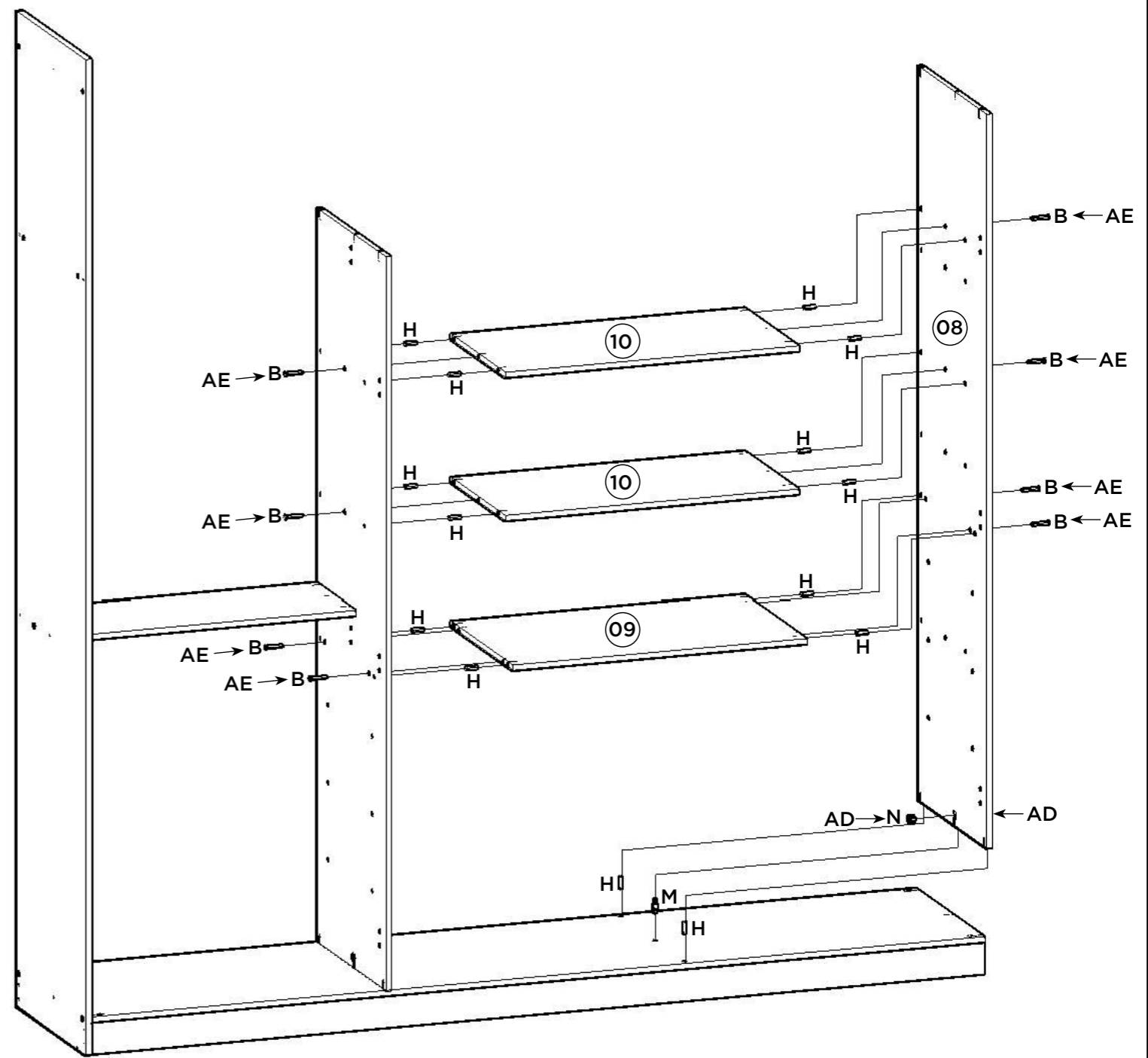
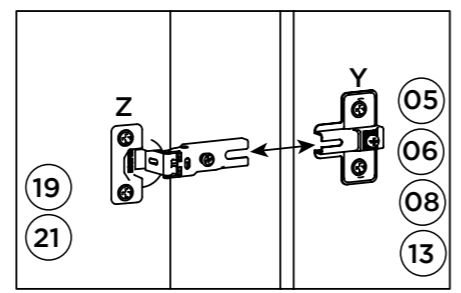
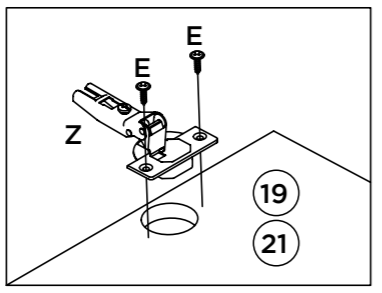
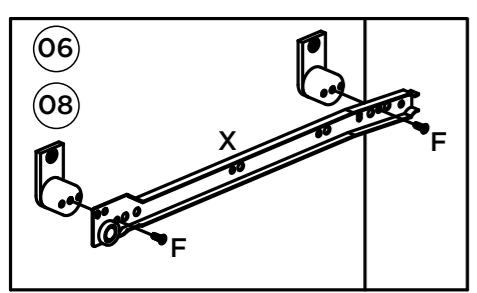
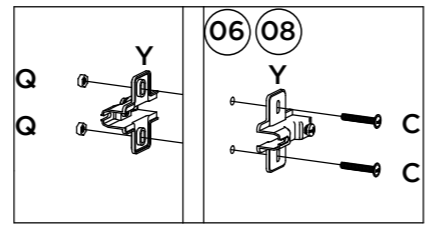
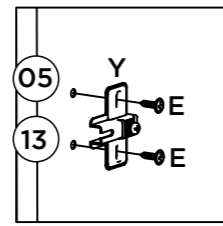
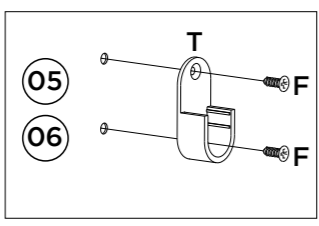
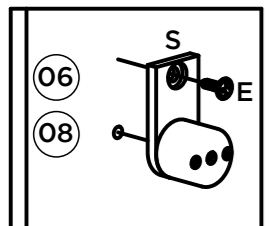

Vídeo: Dicas para fixar o Minifix  
 Vídeo: Consejos para arreglar Minifix  
 Video: Tips for Fixing Minifix

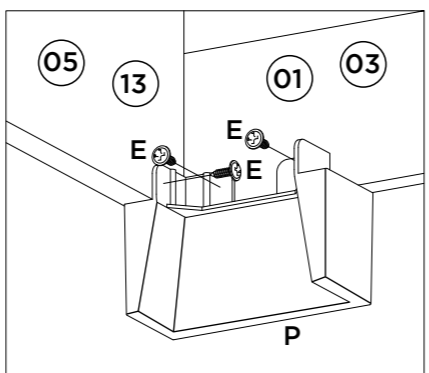
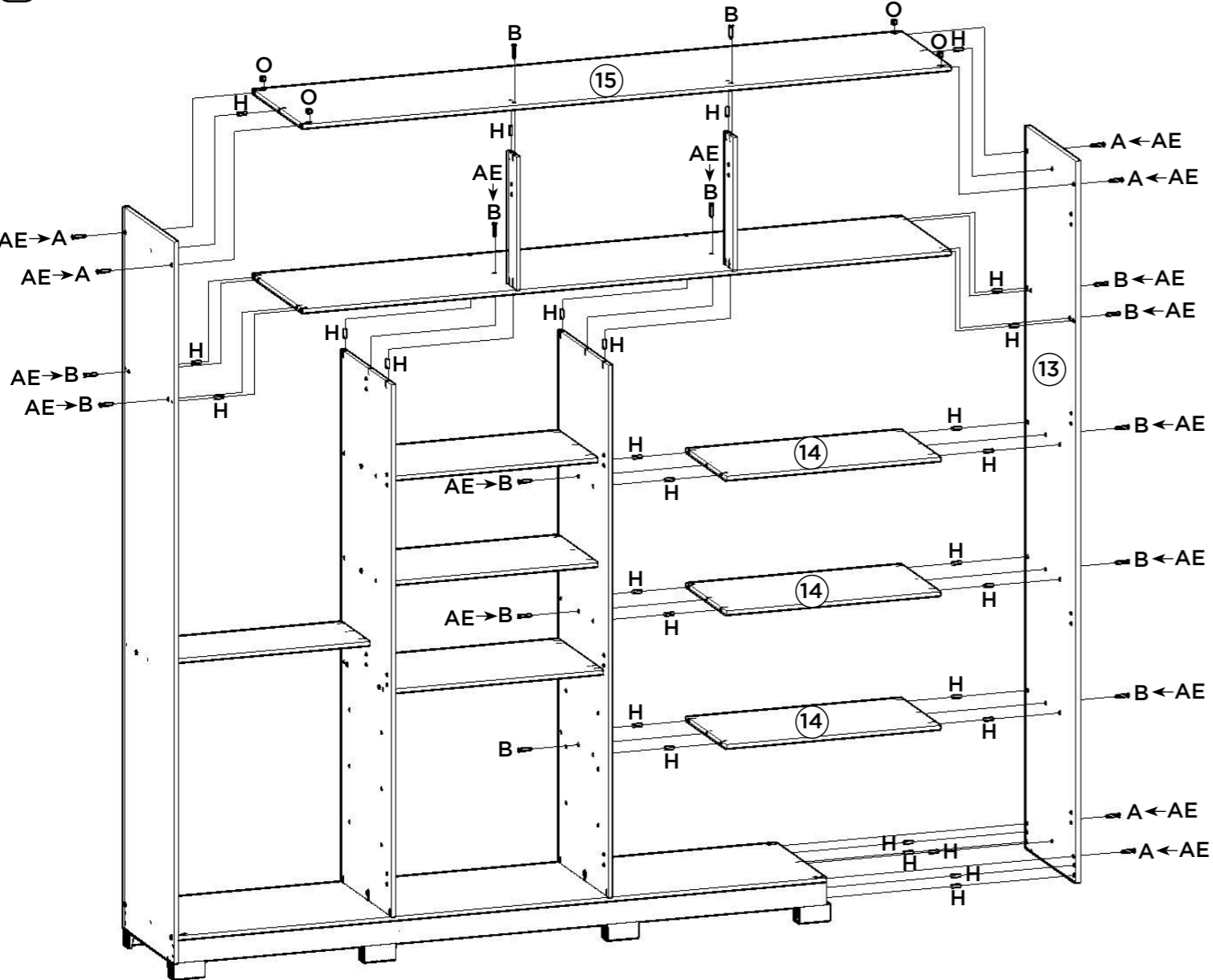
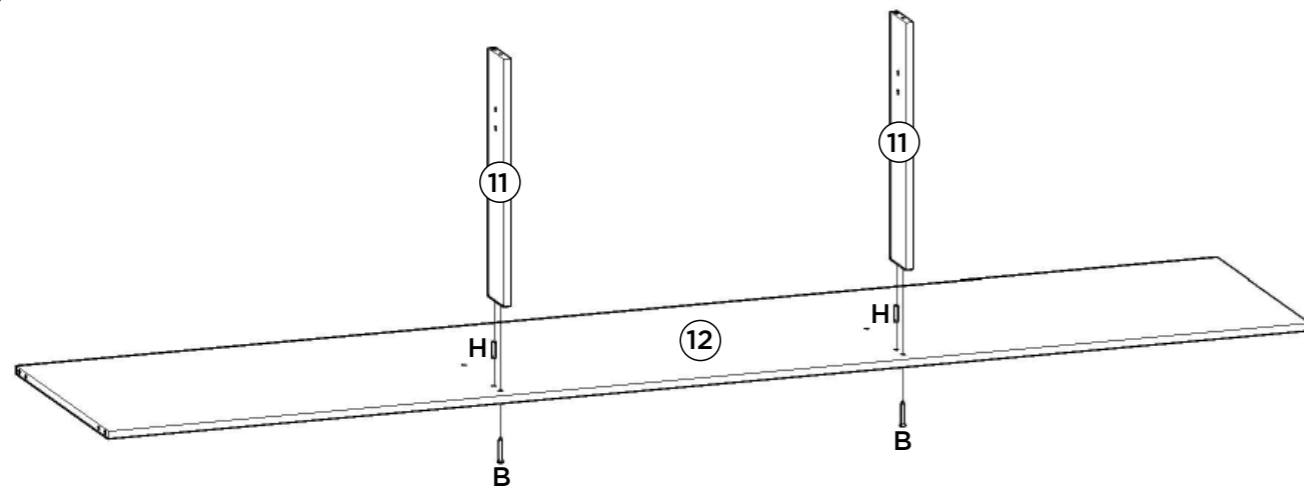

Colocar os pregos (J) a uma distância de 120mm de um para outro.

Coloque los clavos (J) a una distancia de 120 mm uno de otro.

Place the nails (J) at a distance of 120mm from one another.

