

MANUAL COMPLETO COMPLETE MANUAL

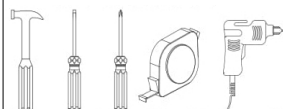

DEMÓBILE Indústria de Móveis Ltda.
Rua : Jurutau, 1350 - Pq. Industrial II.
Cep.: 86703-070
Arapongas - PR - Brasil
demobile@demobile.com.br



Avisos

1. Ler atentamente as instruções do manual antes de iniciar a montagem do móvel.
2. A montagem deverá ser feita em superfície limpa e plana, aconselhamos forrar o chão com a embalagem do produto, para não danificar.
3. Os parafusos devem ser apertados periodicamente.
4. Evitar batidas e contato com objetos cortantes.
5. O peso máximo de carga informado refere-se a objetos distribuídos de maneira uniforme sobre toda área de contato da peça.

Limpeza e Conservação

Efetuar a limpeza somente com pano macio limpo e seco.
Não Utilizar produtos abrasivos ou químicos.

Garantia

1. O fabricante responsabiliza-se apenas pelas peças do produto.
2. A montagem incorreta acarretará na perda da garantia e das assistências, desta forma o produto deverá ser montado por profissional qualificado.
3. Não estão cobertos pela garantia problemas que tenham origem na utilização inadequada do produto ou na exposição do mesmo a intempéries como: infiltrações, infestação de pragas em geral, aparecimento de mofo e outros, decorrentes do ambiente de instalação.

Assistência Técnica: Em caso de peças em assistência técnica é necessário que as mesmas sejam solicitadas junto a loja ou site no qual a compra do produto foi realizada

Warnings

1. Read the manual instructions carefully before starting to assemble the furniture.
2. The assembly must be done in clean and flat surface, we advise to put the product packaging on the floor, not to damage it during the assembling.
3. The screws must be tightened periodically.
4. Avoid hitting and contacting sharp objects.
5. The payload informed refers to the objects distributed all over the piece contact area.

Cleaning and conservation

Clean the product just with a soft, cleaned and dry cloth.
Do not use abrasive or chemicals products.

Warranty

1. The manufacturer is only responsible for product parts.
2. Incorrect assembling will make you lost the guarantee and assistance, in this way the product must be assembled by qualified professional.
3. It is Not covered by the warranty problems caused by an inappropriate use of the product or product exposure even in bad weather, such as: infiltrations, pest infestation in general, appearance of mold and others, caused by the installation environment.

Technical Assistance: Damaged pieces! Ask on the stores you bought it.

Advertencias

1. Lee atentamente las instrucciones del manual antes de empezar a armar los muebles.
2. El montaje debe hacerse en superficie limpia y plana, utilice el empaque del Producto para cubrir el piso
3. Los tornillos deben ser apretados periódicamente
4. Evite golpear y chocar objetos punzantes
5. El peso máximo de carga tiene relación a los objetos distribuydos sobre toda el área de contacto de la pieza.

Limpeza y conservación

Limpiar solo con un trapo suave, limpio y seco
No utilice productos abrasivos o productos químicos

Garantía

1. El fabricante solo es responsable a las partes del producto.
2. Armar incorrectamente supone la pérdida de garantía y repuestos, de esta manera el producto debe ser ensamblado por profesional calificado
3. No es garantizado problemas derivados del uso inapropiado del producto, o exposición del producto al mal tiempo, como: Infiltraciones, infestación de plagas en general, aparición de moho y otros.

Asistencia técnica: en caso de piezas rotas es necesario que sea solicitadas las mismas a la tienda o sitio web donde se compró el producto.

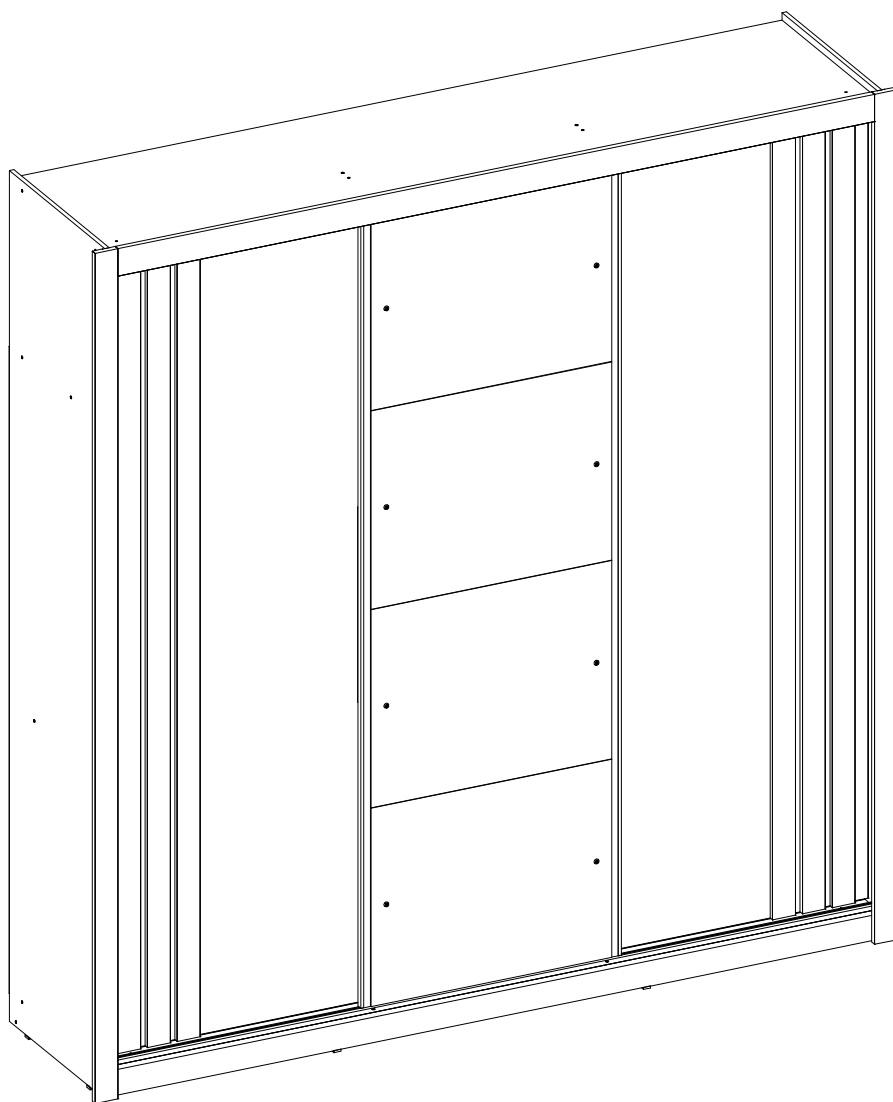

32220 GUARDA ROUPA CASAL 03 PORTAS 02 GAV MOEMA

32220 WARDROBE 03 DOORS 02 DRAWERS MOEMA

32220 CLOSET MATRIMONIAL 03 PUERTAS 02 CAJONES MOEMA

32220

GUARDA ROUPA CASAL 03 PORTAS 02 GAV MOEMA

WARDROBE 03 DOORS 02 DRAWERS MOEMA

CLOSET MATRIMONIAL 03 PUERTAS 02 CAJONES MOEMA

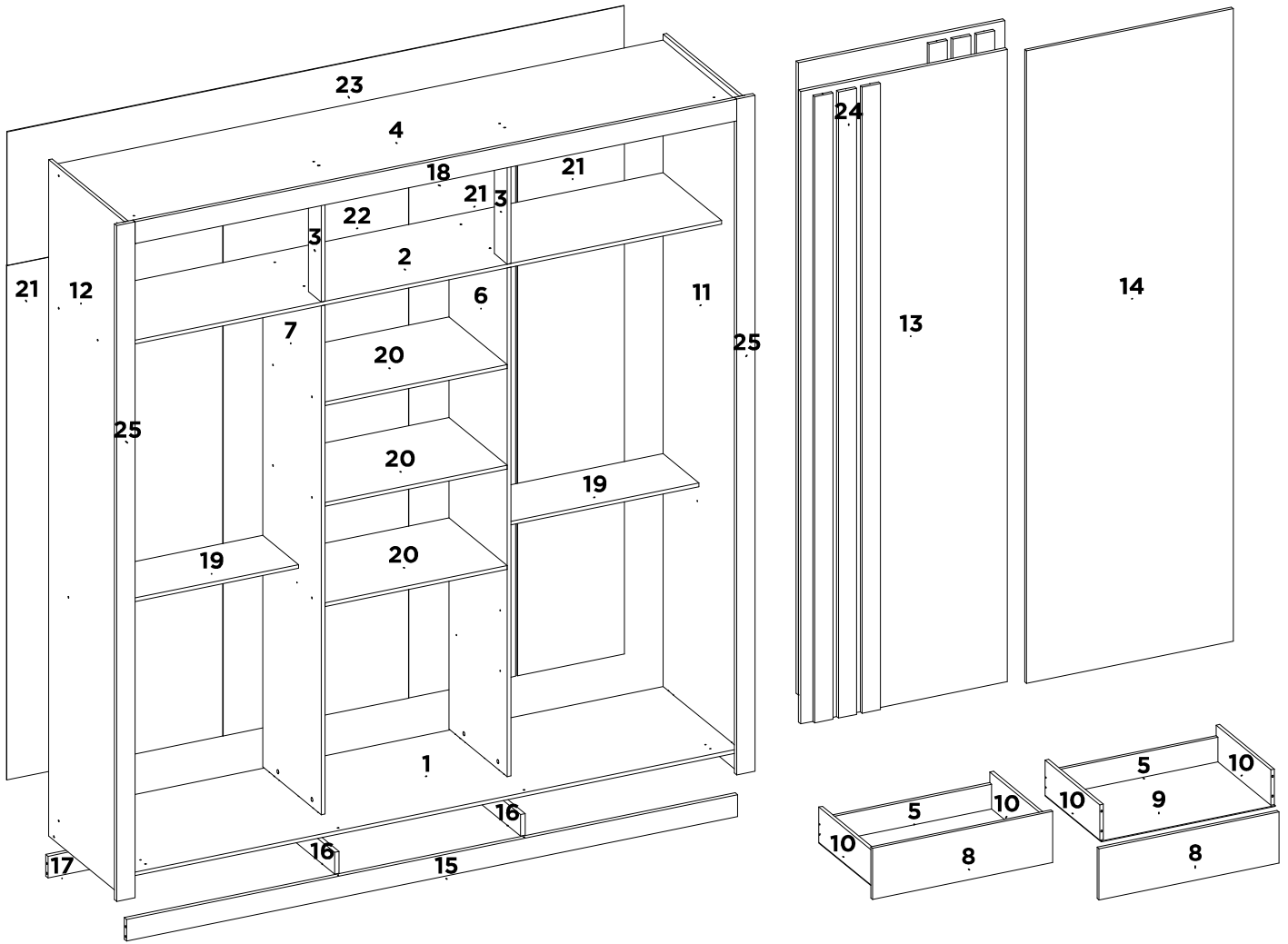

SEQ.	CODIGO	AMENDOLA NUDE PRETO PRIME TX	REF_01	REF_02	REF_03	REF_04	REF_05	REF_06	REF_07	DESCRIÇÃO DE PECAS DESCRIPTION OF PARTS DESCRIPCION DE LAS PIEZAS	DESCRIPTION_EN	DESCRIPCION_ES	DIMENSÕES / QUANTIDADE DIMENSIONS / QUANTITY DIMENSIONES / CANTIDAD	QTD
1	03326	138	-	-	-	-	-	-	-	BASE	BASE	BASE	2010 X 500 X 12	1
2	04042	138	-	-	-	-	-	-	-	BASE DO MALEIRO	TOP	TAPA	2010 X 385 X 12	1
3	05072	138	-	-	-	-	-	-	-	BATENTE FRONTAL	SOPORTE FRONTAL	SOPORTE FRONTAL	415 X 85 X 12	2
4	07232	138	-	-	-	-	-	-	-	CHAPEU	TOP PANEL	TAPA SUPERIOR DEL ROPERO	2010 X 500 X 12	1
5	06069	138	-	-	-	-	-	-	-	CONTRA FUNDO	DRAWER BACK	CONTRA FONDO	551 X 80 X 12	2
6	08156	138	-	-	-	-	-	-	-	DIVISAO DIREITA	RIGHT DIVISION	DIVISION DERECHA	1640 X 385 X 12	1
7	08155	138	-	-	-	-	-	-	-	DIVISAO ESQUERDA	LEFT DIVISION	DIVISION IZQUIERDA	1640 X 385 X 12	1
8	09092	138	-	-	-	-	-	-	-	FRENTE DE GAVETA	DRAWER FRONT	FRENTE DEL CAJON	592 X 165 X 12	2
9	10060	138	-	-	-	-	-	-	-	FUNDO GAVETA	DRAWER BASE	FONDO DEL CAJÓN	573 X 368 X 3	2
10	12004	138	-	-	-	-	-	-	-	LATERAL DE GAVETA	DRAWER SIDE	LATERAL DEL CAJON	360 X 114 X 12	4
11	11195	136	-	-	-	-	-	-	-	LATERAL DIREITA	SIDE PANEL RIGHT	LATERAL DERECHA	2180 X 500 X 12	1
12	11196	136	-	-	-	-	-	-	-	LATERAL ESQUERDA	SIDE PANEL LEFT	LATERAL IZQUIERDA	2180 X 500 X 12	1
13	14485	195	-	-	-	-	-	-	-	PORTA DE CORRER	SLIDING DOOR	PUERTA CORREDIZA	2038 X 680 X 15	2
14	14258	195	-	-	-	-	-	-	-	PORTA DE CORRER CENTRAL	SLIDING DOOR	PUERTA CORREDIZA	2038 X 680 X 12	1
15	16188	134	-	-	-	-	-	-	-	RODAPE FRONTAL	BOTTOM BOARD FRONT	ZÓCALO FRONTAL	2010 X 70 X 15	1
16	16190	20	-	-	-	-	-	-	-	RODAPE INTERNO	BOTTOM BOARD INTERNAL	ZÓCALO INTERNO	433 X 70 X 15	2
17	16189	20	-	-	-	-	-	-	-	RODAPE TRASEIRO	BOTTOM BOARD BACK	ZÓCALO TRASERO	2010 X 70 X 15	1
18	17052	134	-	-	-	-	-	-	-	RODATETO	WHEEL CEILING	RODATETO	1980 X 70 X 15	1
19	19127	138	-	-	-	-	-	-	-	TAMPO CALCEIRO	SHELF	ESTANTERIA	693 X 235 X 12	2
20	19126	138	-	-	-	-	-	-	-	TAMPO PRATELEIRA	SHELF	ESTANTERIA	600 X 385 X 12	3
21	20344	138	-	-	-	-	-	-	-	TRASEIRO	BACK PANEL	TRASERO	1658 X 352 X 3	4
22	20194	138	-	-	-	-	-	-	-	TRASEIRO CENTRAL	BACK PANEL	TRASERO	1658 X 610 X 3	1
23	20192	138	-	-	-	-	-	-	-	TRASEIRO DO MALEIRO	BACK PANEL	TRASERO	2030 X 431 X 3	1
24	29168	134	-	-	-	-	-	-	-	VISTA FRONTAL	FRONT FRAME	MARCO FRONTAL	2018 X 60 X 12	6
25	29040	134	-	-	-	-	-	-	-	VISTA LATERAL	SIDE VIEW	VISTA LATERAL	2178 X 60 X 15	2

LISTA DE ACESSÓRIOS / LIST OF ACCESSORIES / LISTA DE ACCESORIOS

SEQ.	CODIGO.	DESCRIÇÃO	DESCRIPTION_EN	DESCRIPCION_ES	QTD.
-	260144	KIT DE ACESSÓRIOS	KIT OF ACCESSORIES	KIT DE ACCESORIOS	1
A	9905002	PARAFUSO 3.5 X 12 MM CHATA PHILIPS	PHILIPS FLAT HEAD SCREW	TORNILLO CHATA PHILIPS	66
B	9905003	PARAFUSO 3.5 X 12 MM FLANGEADO PHILIPS	PHILIPS FLANGE SCREW	TORNILLO DE BRIDA PHILIPS	38
BF	9920051	SISTEMA PORTA CORRER KIT 03 PORTAS	SLIDING DOOR SYSTEM	SISTEMA DE PUERTAS CORREDERAS	1
C	9905046	PARAFUSO 3.5 X 14 MM CHATA PHILIPS	PHILIPS FLAT HEAD SCREW	TORNILLO CHATA PHILIPS	22
CD	9919091	TRILHO U 2009 MM PLASTICO CANAL 28 MM	PLASTIC U RAIL CHANNEL	CANAL DE RIEL EN U DE PLÁSTICO	2
CE	9919090	TRILHO SUSPENSO 2009 MM ALUMINIO	ALUMINI SUSPENDED RAIL	RIEL ALUMINI SUSPENDIDO	2
D	9905018	PARAFUSO 3.5 X 25 MM CHATA PHILIPS	PHILIPS FLAT HEAD SCREW	TORNILLO CHATA PHILIPS	44
DB	9901048	CABIDEIRO OBLONGO 685 X 20 X 15 MM ALUMINIO	HANGER	PERCHERO	4
EA	9902032	MOLDURA DE ALUMINIO 2036 X 12 MM CHAPA12 MM COD 913 ABA FRONTAL 8 MM PRATA	ALUMINUM FRAME	MARCO DE ALUMINIO	2
H	9905045	PARAFUSO 4 X 45 MM CHATA PHILIPS	PHILIPS FLAT HEAD SCREW	TORNILLO CHATA PHILIPS	40
I	9905017	PARAFUSO 6 X 12 MM CHATA PHILIPS	PHILIPS FLAT HEAD SCREW	TORNILLO CHATA PHILIPS	4
IA	9928009	PERFIL H 1638 X 16 X 6 MM PLASTICO	PLASTIC H STRIP	TIRA PLASTICA H	2
J	9920029	PINO MINIFIX 12 MM	MINIFIX PIN	PINO MINIFIX	4
K	9920009	CASTANHA MINIFIX 12 MM	MINIFIX CHESTNUT	LOS SIMPSON	4
L	9920011	CAVILHAS 6 X 30 MM	WOODEN PEG	CLAVIJA DE MADERA	48
LA	9917028	ESPELHO 630 X 508 X 3 MM FURADO	MIRROR	ESPEJO	4
M	9920012	CAVILHAS 6 X 50 MM	WOODEN PEG	CLAVIJA DE MADERA	6
MA	9920053	JUNCAO METALICA 50 X 13 MM	METAL JUNCTION	JUNCIÓN METALICA	2
N	9913017	CORREDICA 350 MM METAL LIGHT BIGFER ALBRAS	METAL SLIDE	RIEL METALICO	2
OA	9912006	SACHET DE COLA 10 GRAMAS	GLUE	COLA	1
QB	9905029	PARAFUSO 3.5 X 16 MM CHATA PHILIPS	PHILIPS FLAT HEAD SCREW	TORNILLO CHATA PHILIPS	8
QB	9920063	BUCHA PARA FIXACAO DE ESPELHO	MIRROR BUSHING BUSHING	CASQUILLO DE RETROVISOR	8
R	9920025	FIXADOR 90 GRAUS	90 DEGREE FASTENER	FIJADOR 90 GRADOS	15
S	9920026	FIXADOR DE FUNDO 10 X 10 MM	BOOTOM FASTENER	FIJADOR DE FONDO	40
S2	9920058	SUPORTE TRIANGULAR 14 X 14	TRIANGULAR SUPPORT	APOYO TRIANGULAR	2
S3	9920038	SUPORTE CABIDE OBLONGO 20 MM	HANGER SUPPORT	SOPORTE DE PERCHERO	8
TA	9920060	CARTELA DE SILICONE 10 PINGOS	SILICONE ADHESIVE	ADHESIVO DE SILICONA	1
U	9924002	MINI SAPATA 15 MM	MINI SHOE	MINI ZAPATA	8
V	9920030	PORCA CILINDRICA 9 X 12 MM	CYLINDRICAL NUT	TUERCA CILINDRICA	32
W	9906001	PREGO 12X12 MM	NAIL	CLAVO	8
WA	9902062	MOLDURA ALINHADOR DE ACO 500 X 16 MM CHAPA1.06 MM COD 1557 ABA FRONTAL 7 MM CINZA	STEEL FRAME	MARCO DE ACERO	2
X	9906002	PREGO 9X9 MM	NAIL	CLAVO	150
Y	9920006	CANTONEIRA METALICA 16 MM	METAL ANGLE BRACKET	ESQUINERAS METALICAS	8

Acessórios/Accessories/Accesorios

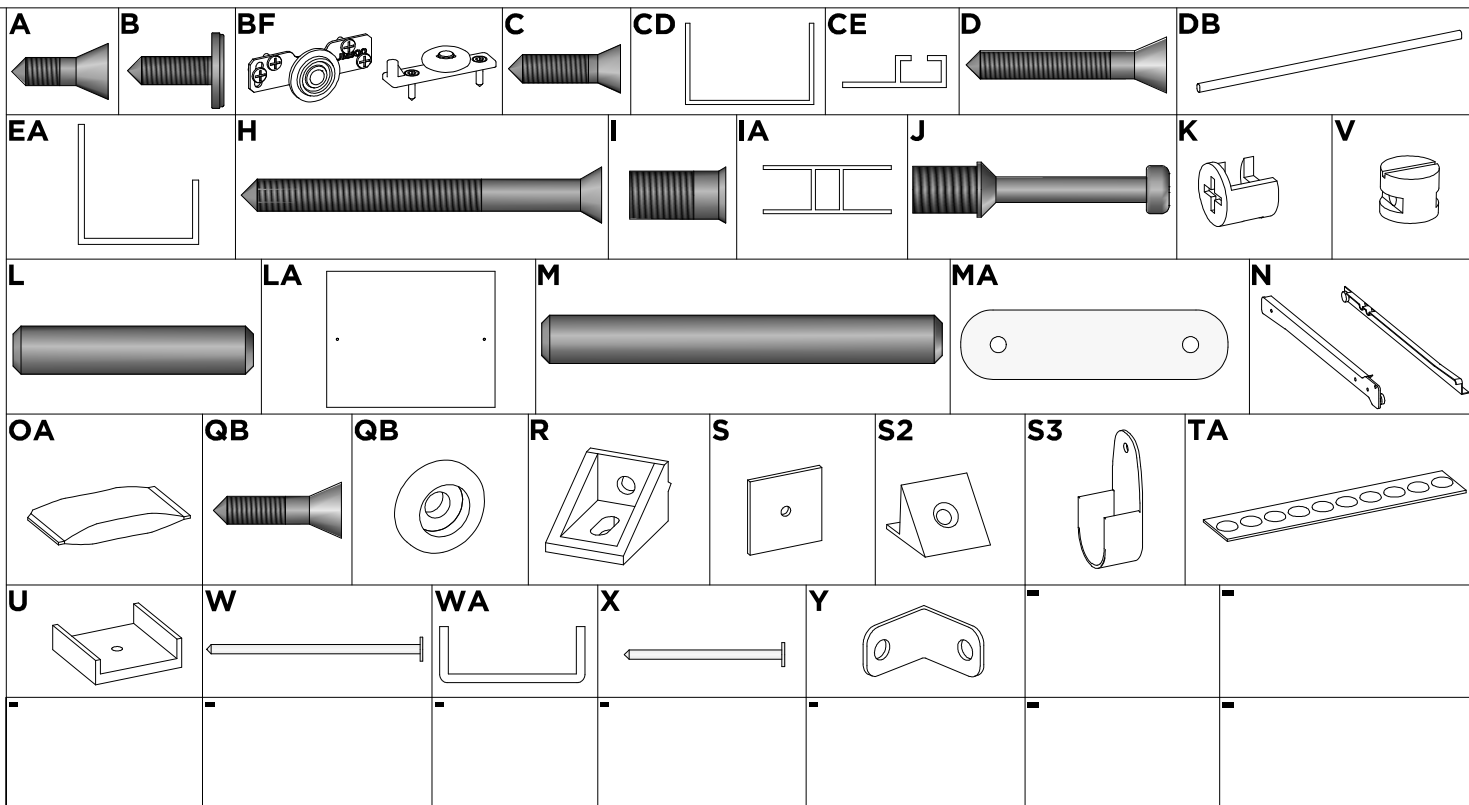

01

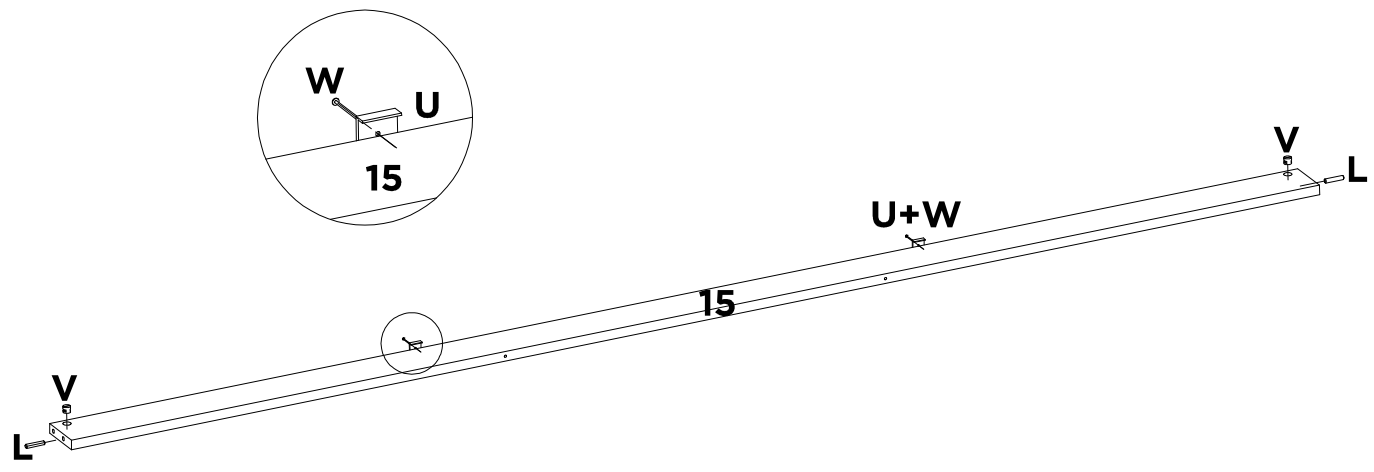

L	U	V	W	-	-	-	-
X2	X2	X2	X2	-	-	-	-

01A

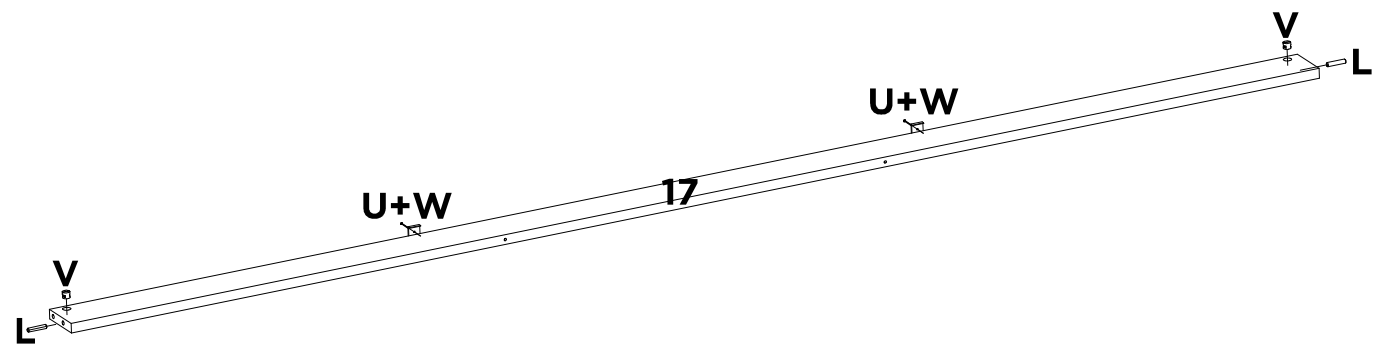

L	U	V	W	-	-	-	-
X2	X2	X2	X2	-	-	-	-

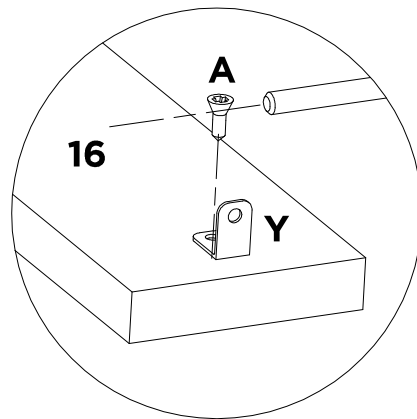
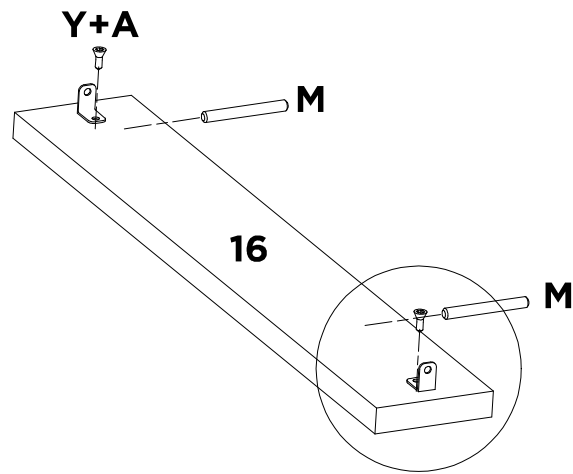

A	M	Y	-	-	-	-	-
X4	X4	X4	-	-	-	-	-

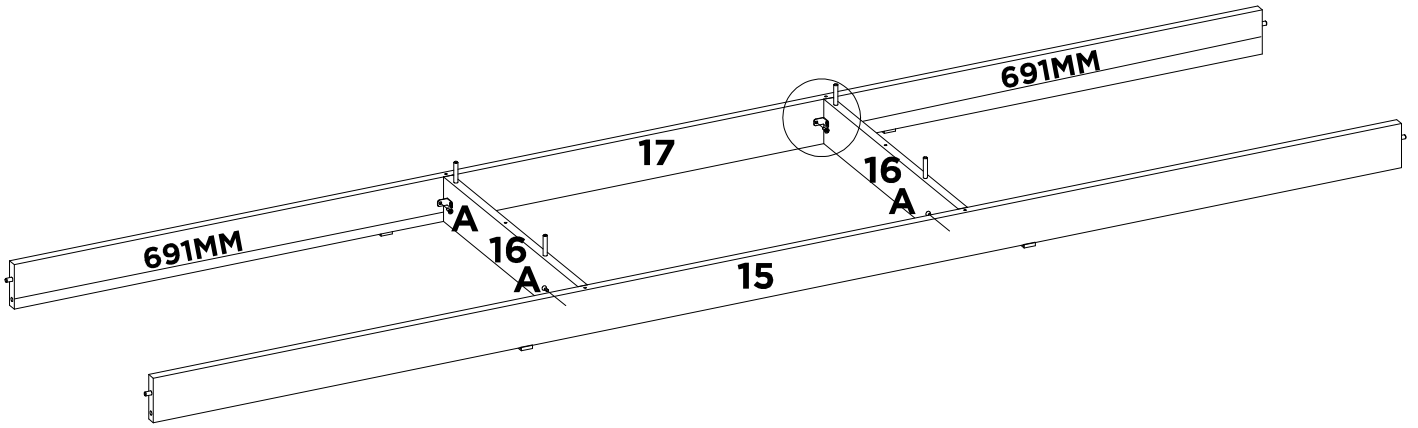
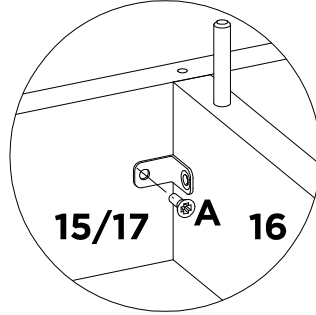

A	-	-	-	-	-	-	-
X4	-	-	-	-	-	-	-

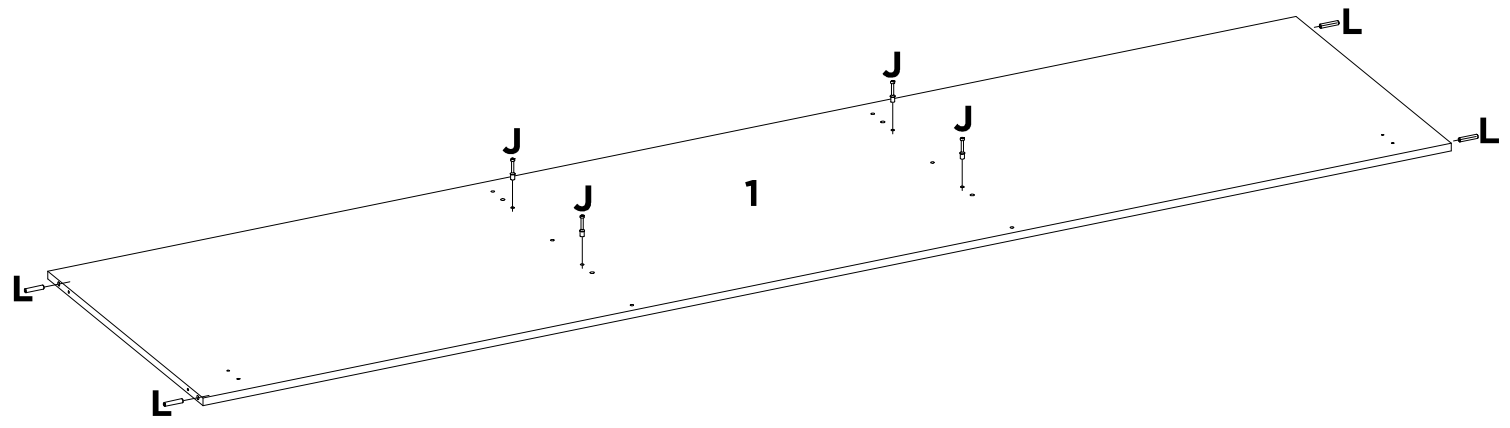

J	L	-	-	-	-	-	-
X4	X4	-	-	-	-	-	-

05

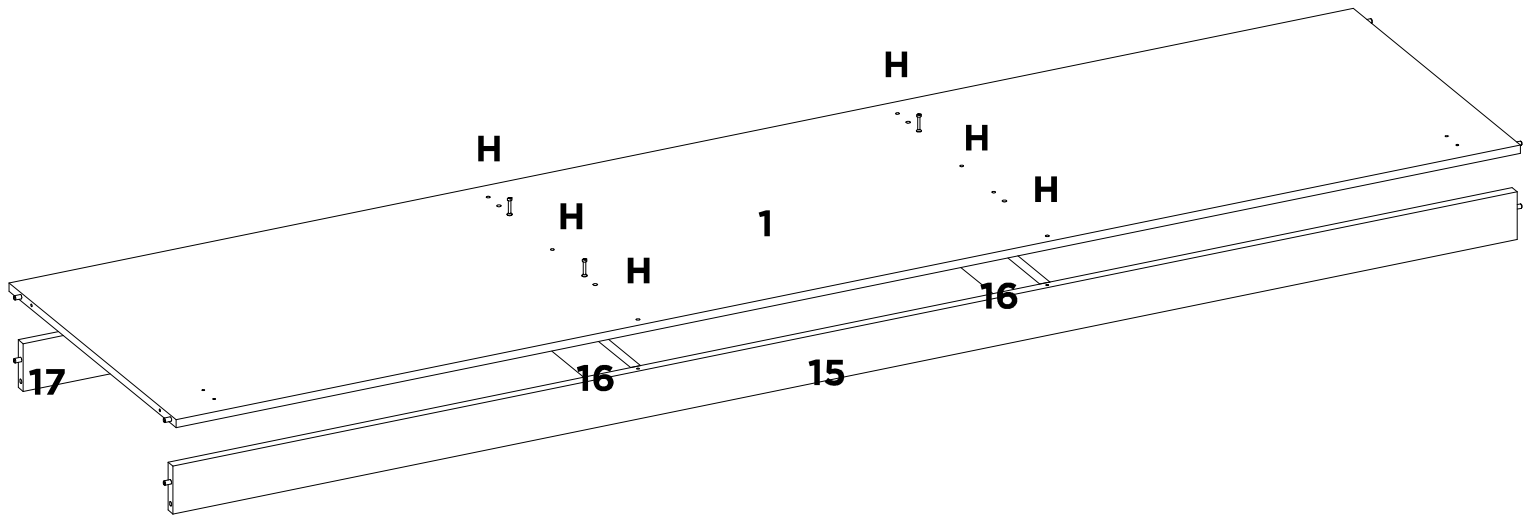

H	-	-	-	-	-	-	-
X6	-	-	-	-	-	-	-

06

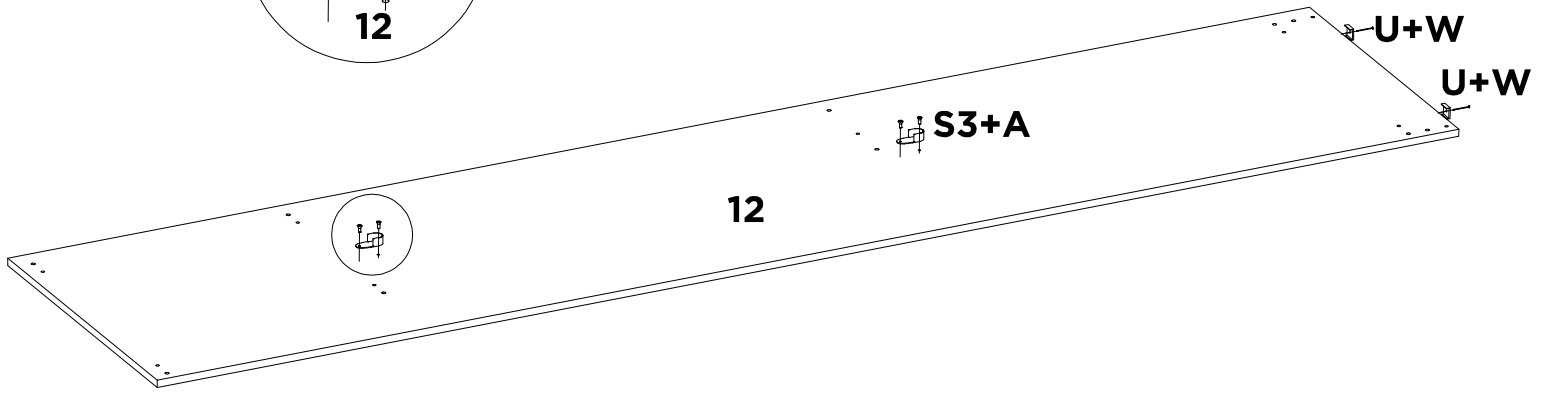
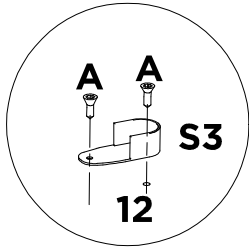

A	S3	U	W	-	-	-	-
X4	X2	X2	X2	-	-	-	-

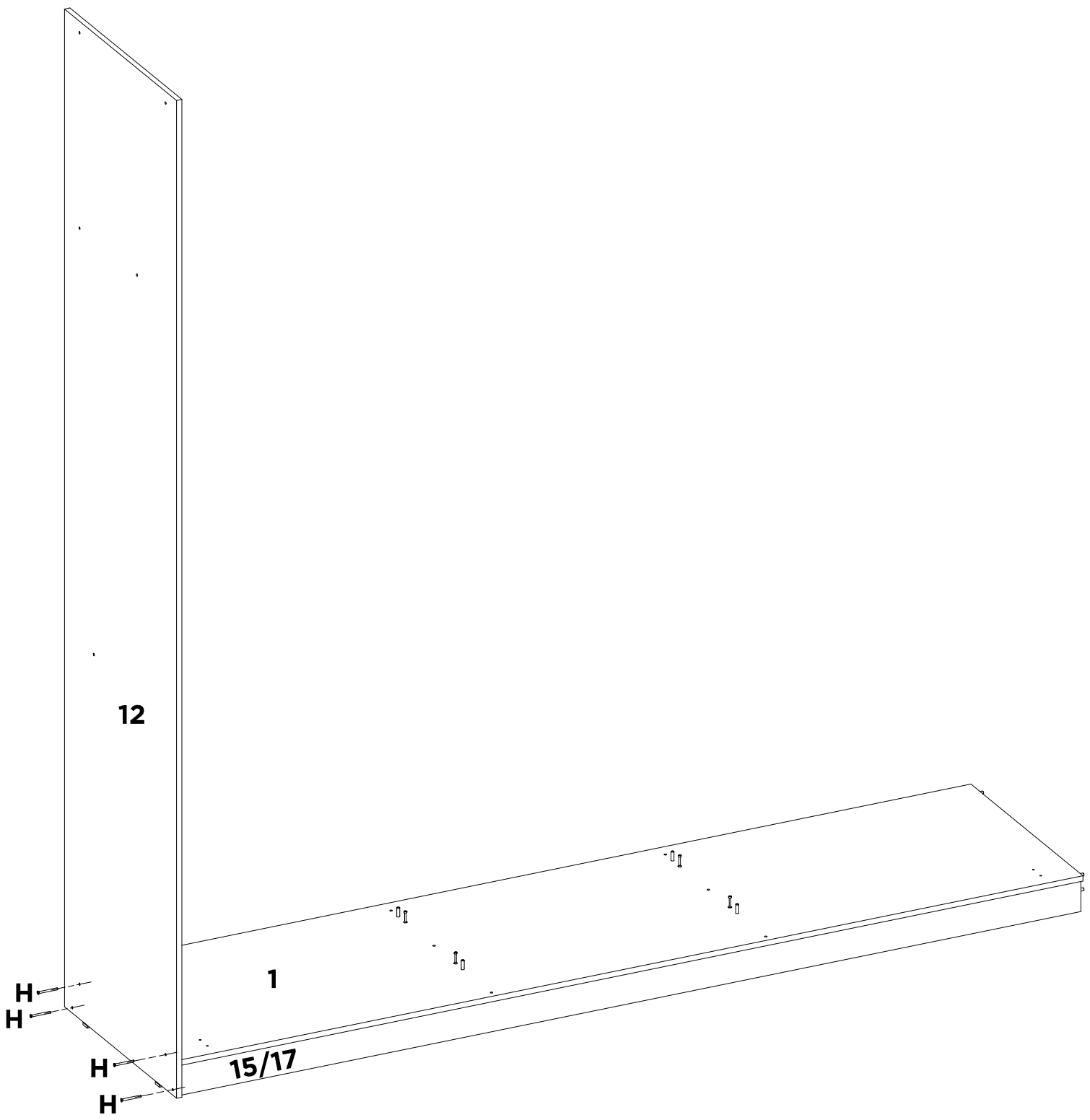

H	-	-	-	-	-	-	-
X4	-	-	-	-	-	-	-

08

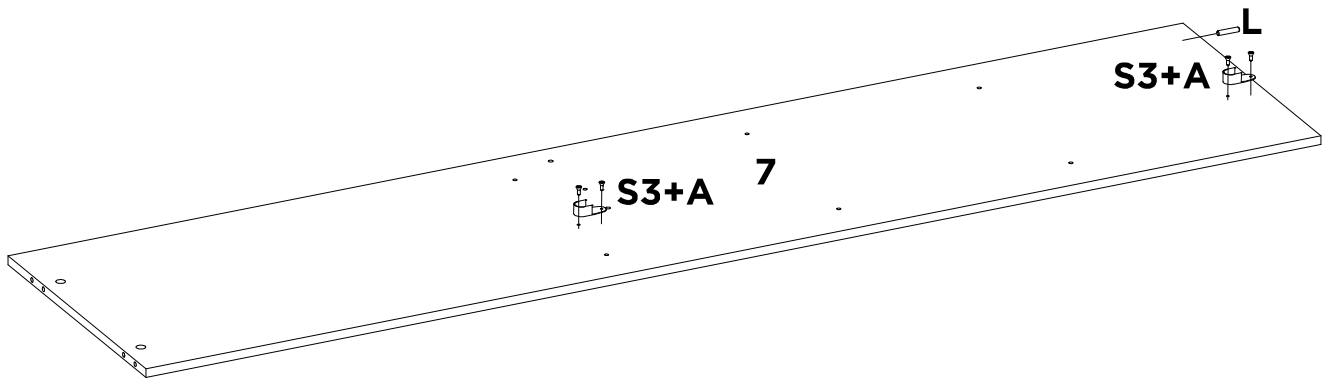

A	L	S3	-	-	-	-	-
X4	X1	X2	-	-	-	-	-

08A

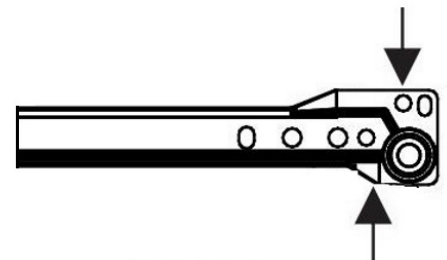
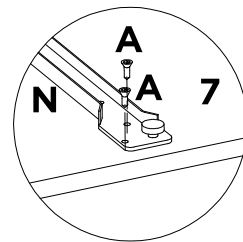
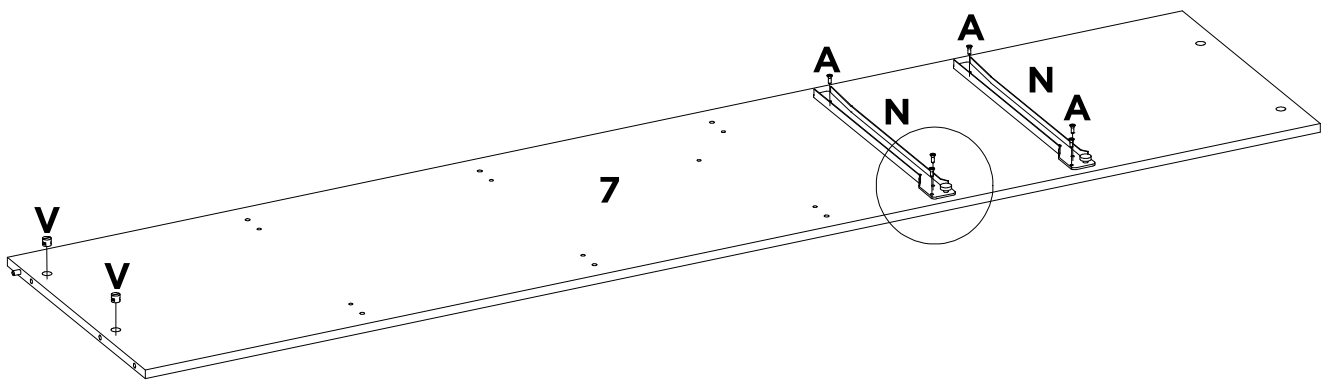

A	N	V	-	-	-	-	-
X6	X2	X2	-	-	-	-	-

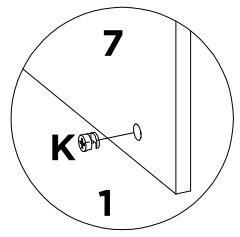
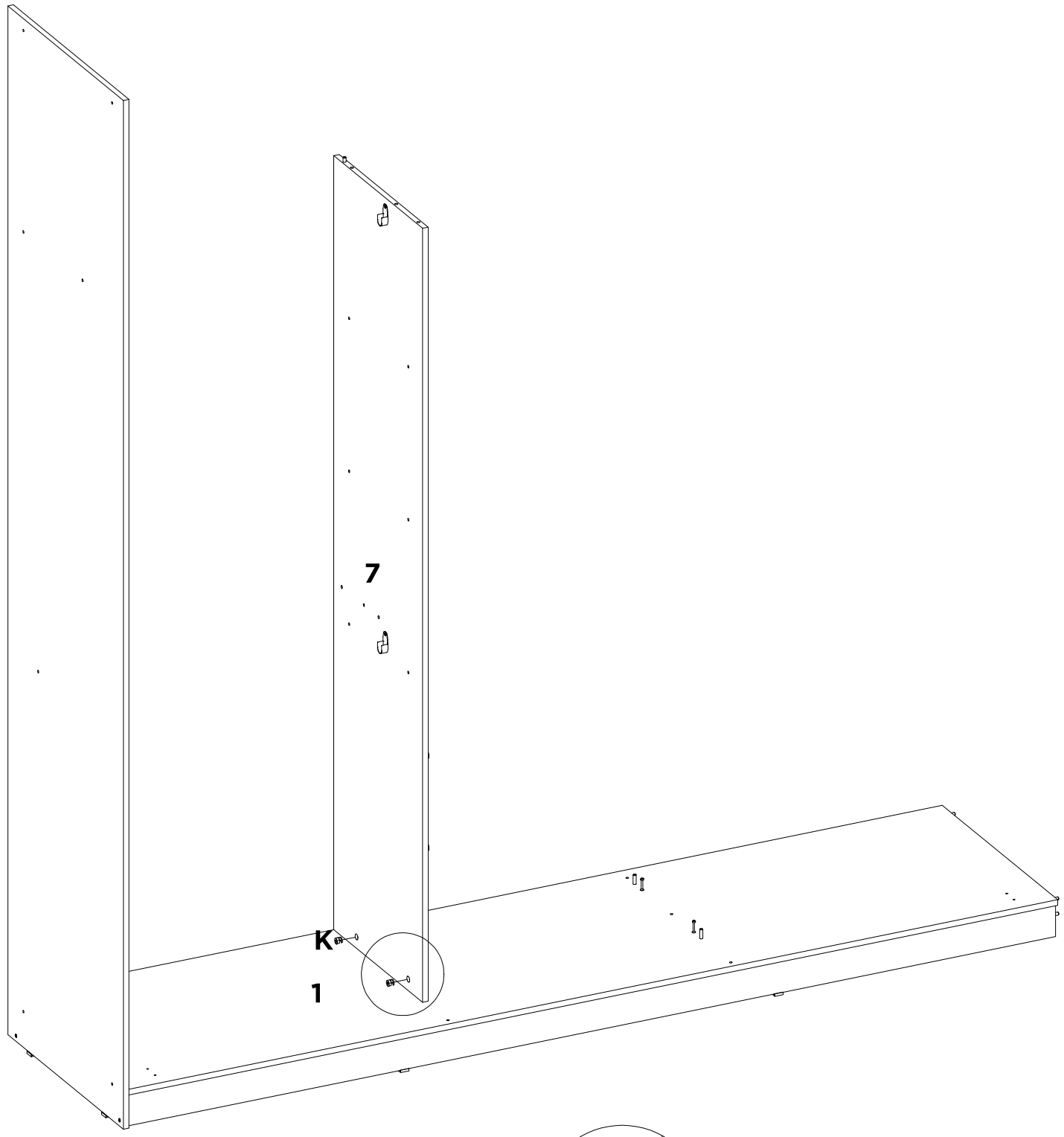

K	-	-	-	-	-	-	-
X2	-	-	-	-	-	-	-

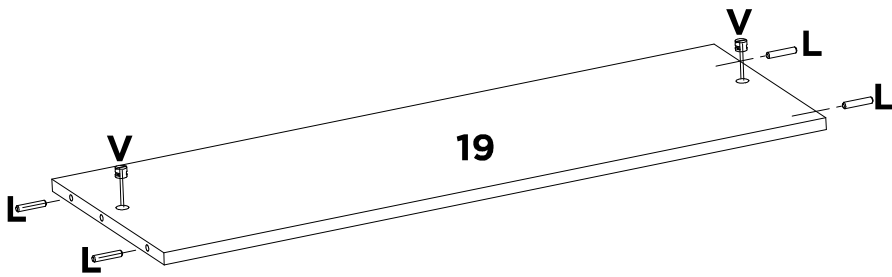

L	V	-	-	-	-	-	-
X8	X4	-	-	-	-	-	-

11

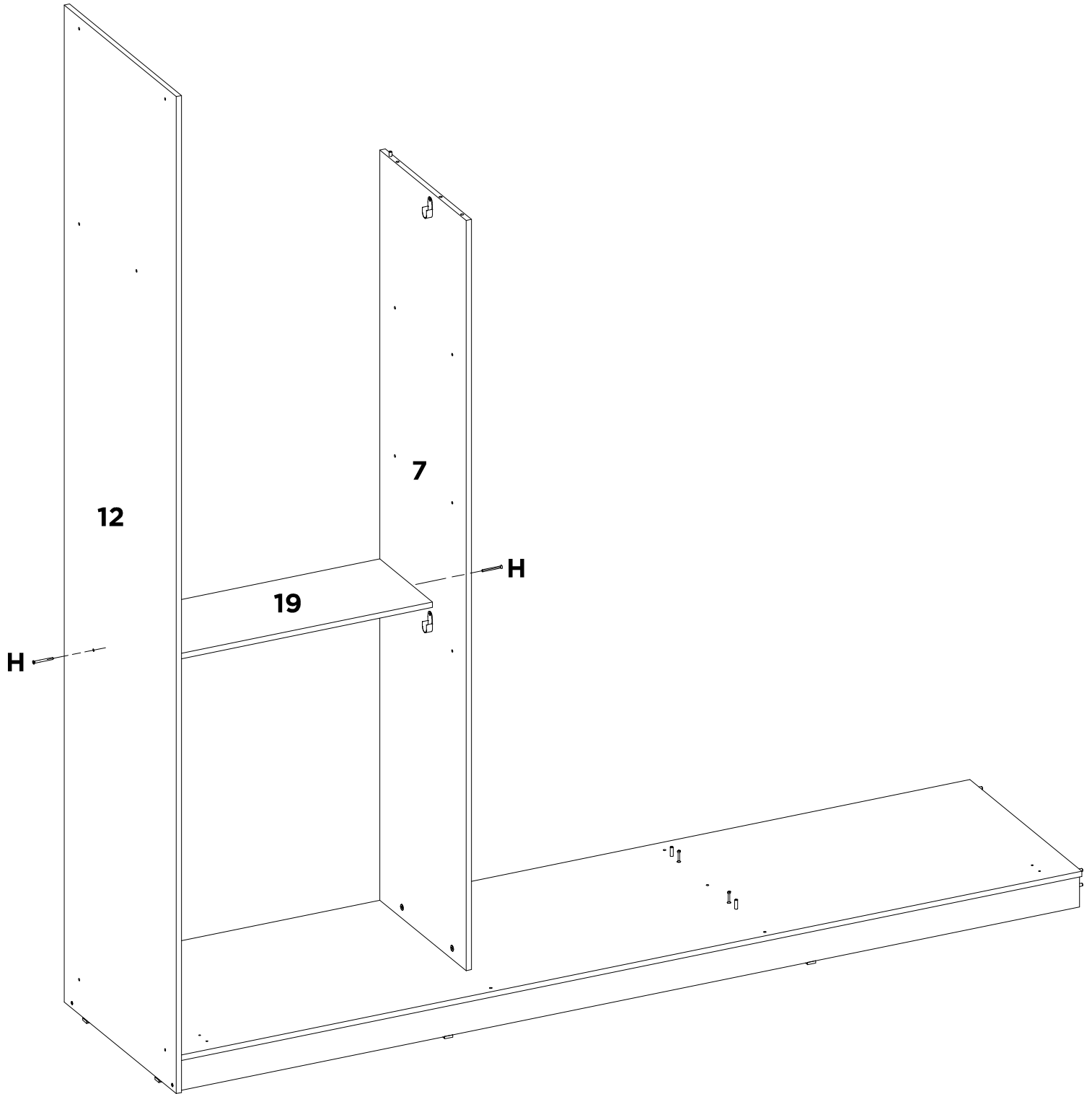

H	-	-	-	-	-	-	-
X2	-	-	-	-	-	-	-

12

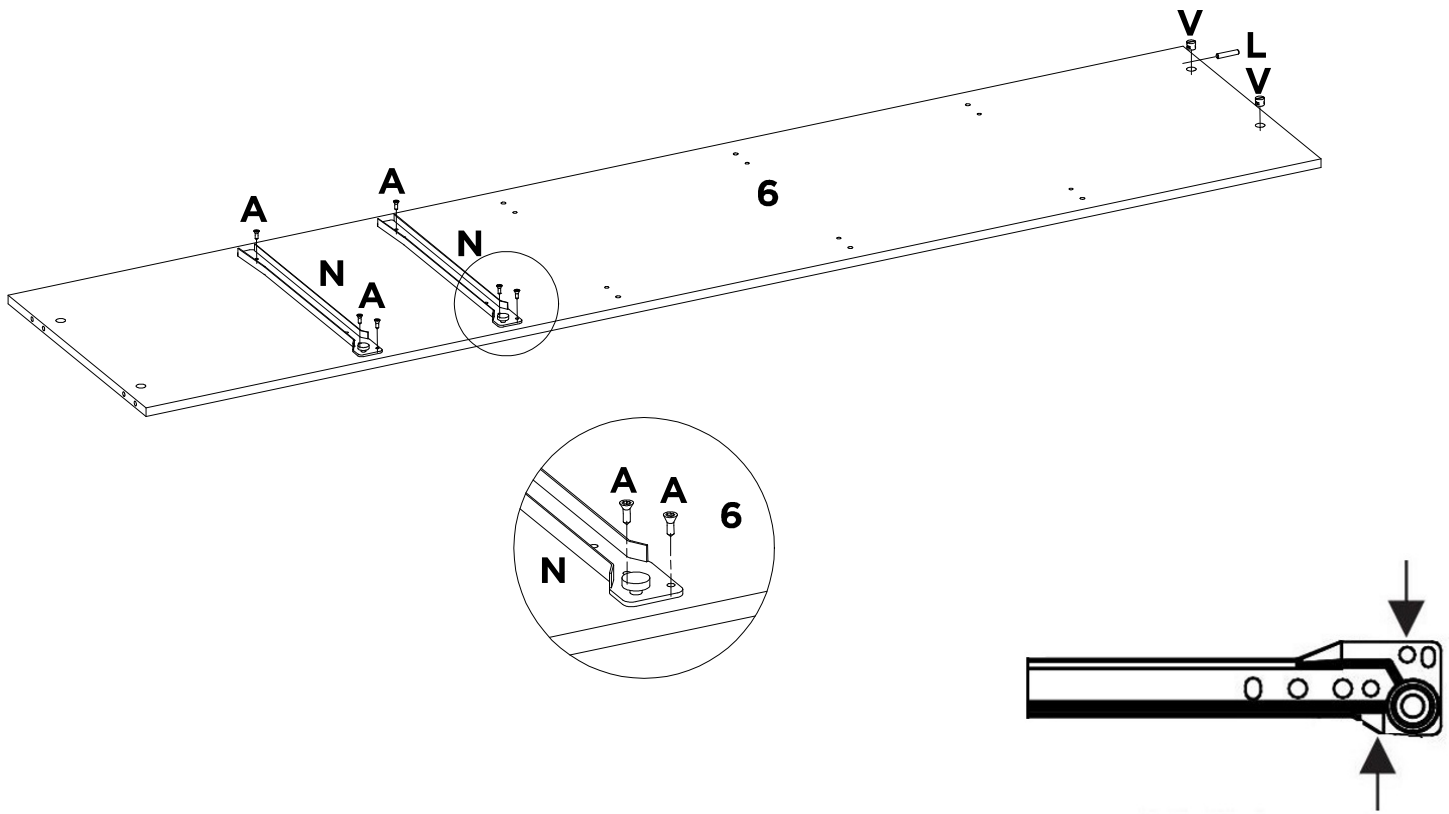

A	L	N	V	-	-	-	-
X6	X1	X2	X2	-	-	-	-

12A

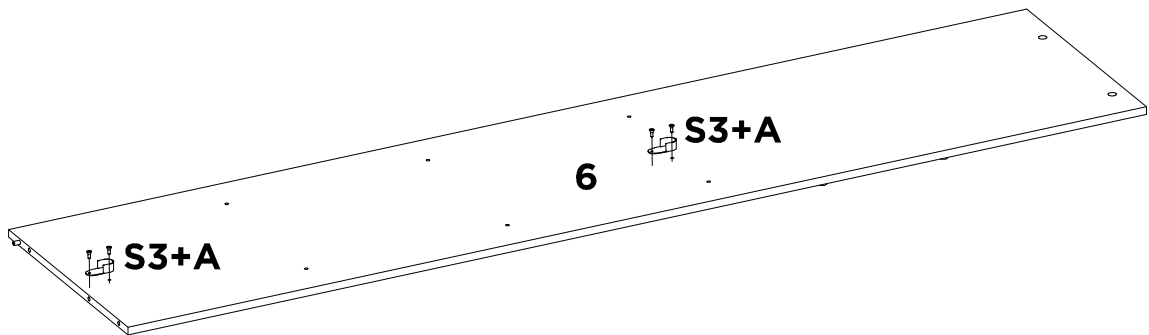

A	S3	-	-	-	-	-	-
X4	X2	-	-	-	-	-	-

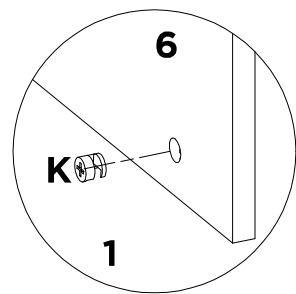
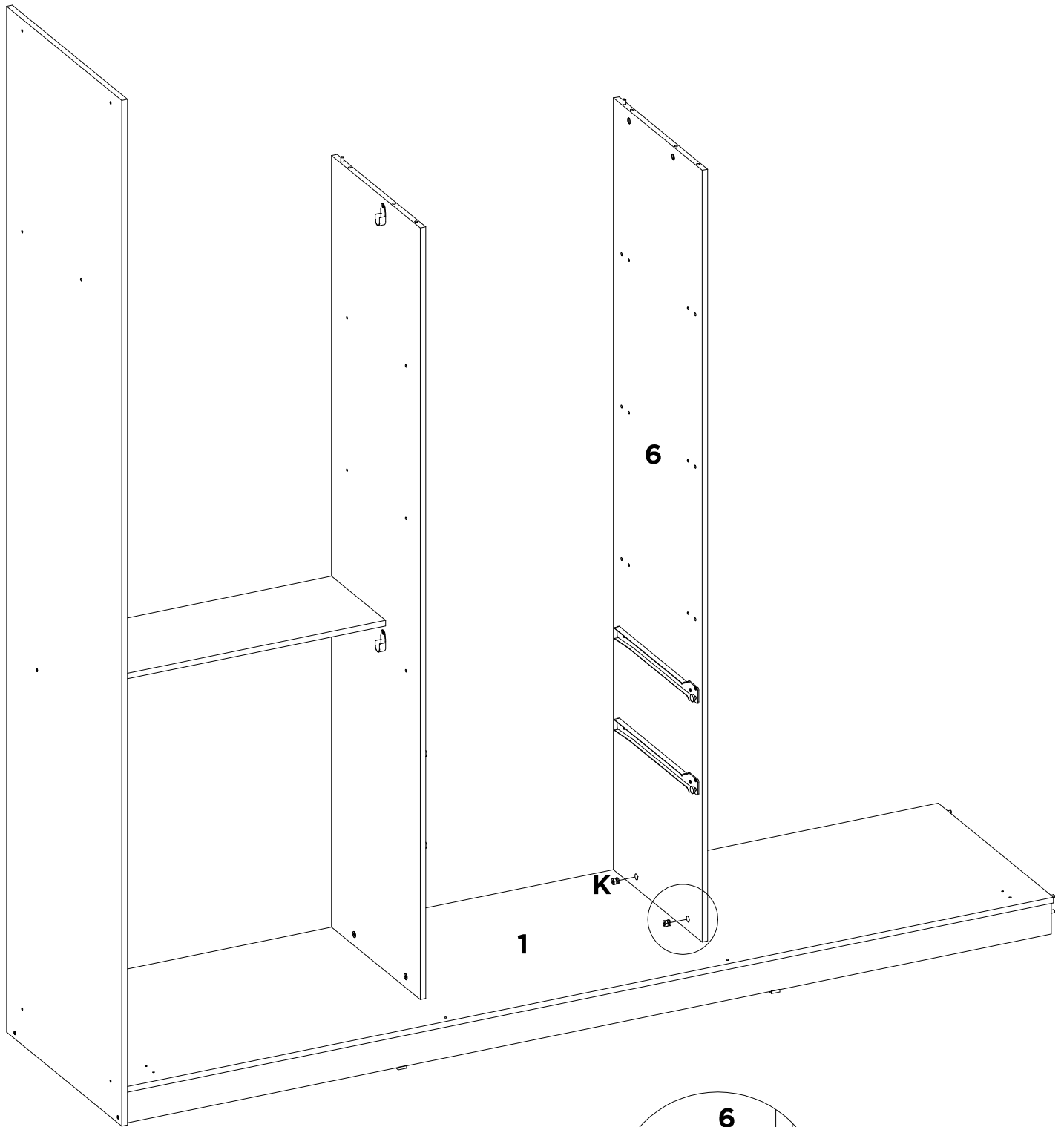

K	-	-	-	-	-	-	-
X2	-	-	-	-	-	-	-

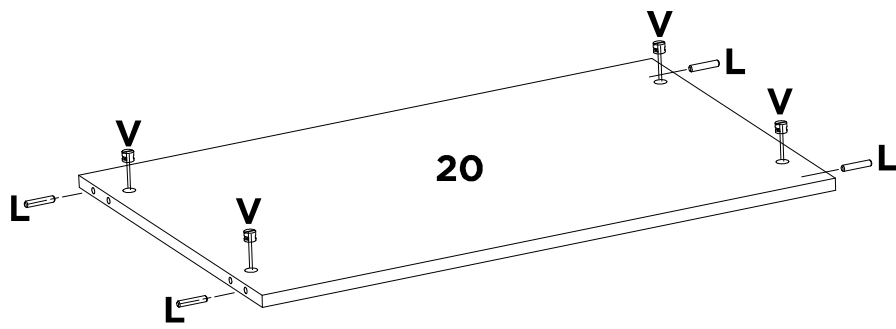

L	V	-	-	-	-	-	-
X12	X12	-	-	-	-	-	-

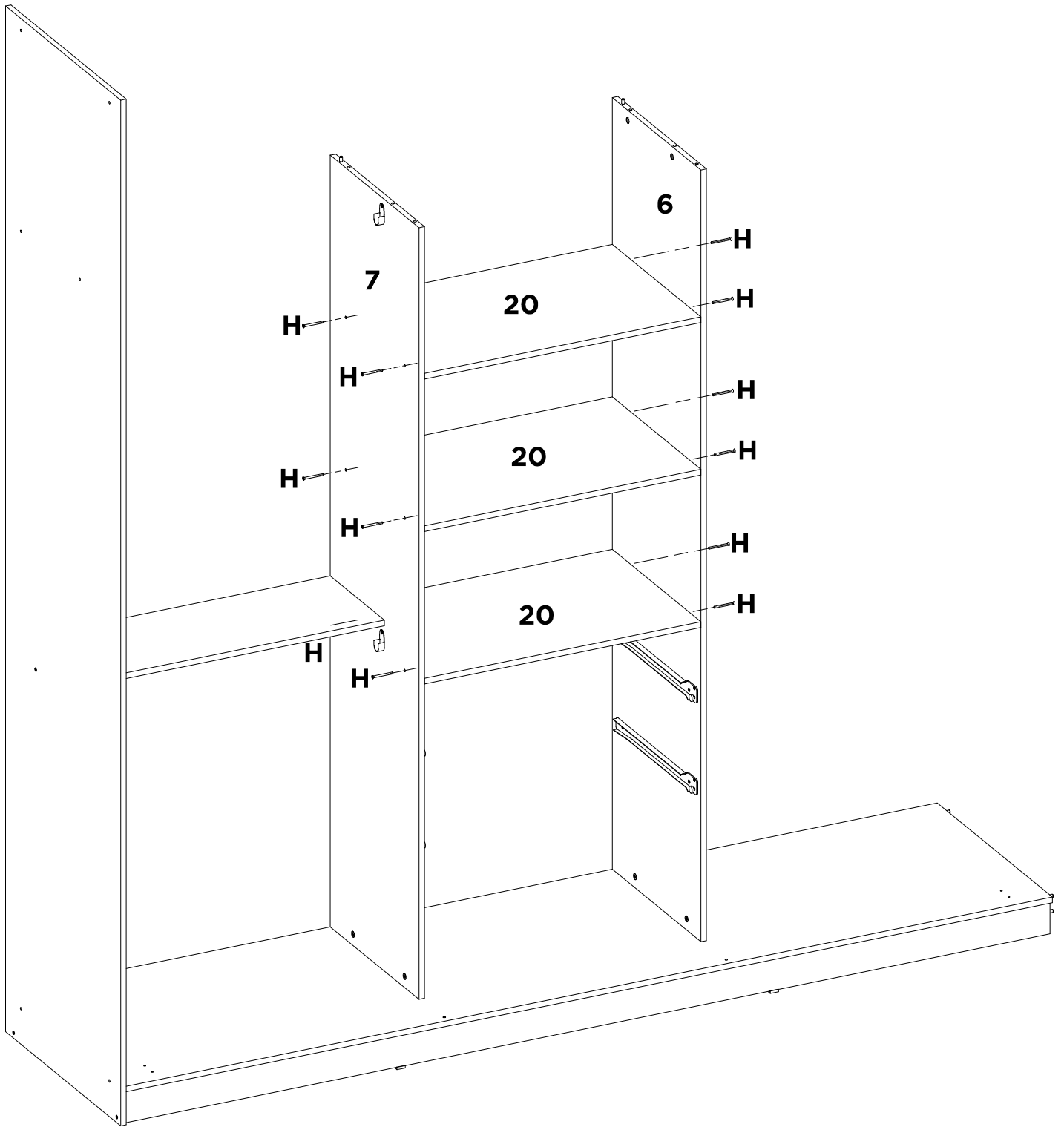

H	-	-	-	-	-	-	-
X12	-	-	-	-	-	-	-

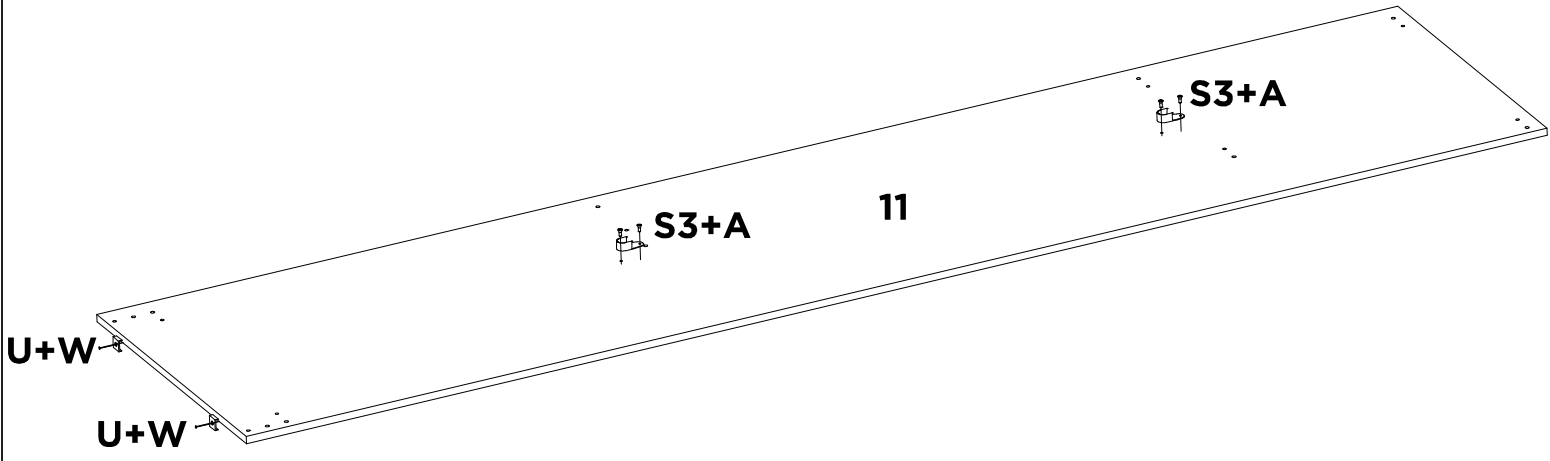

A	S3	U	W	-	-	-	-
X4	X2	X2	X2	-	-	-	-

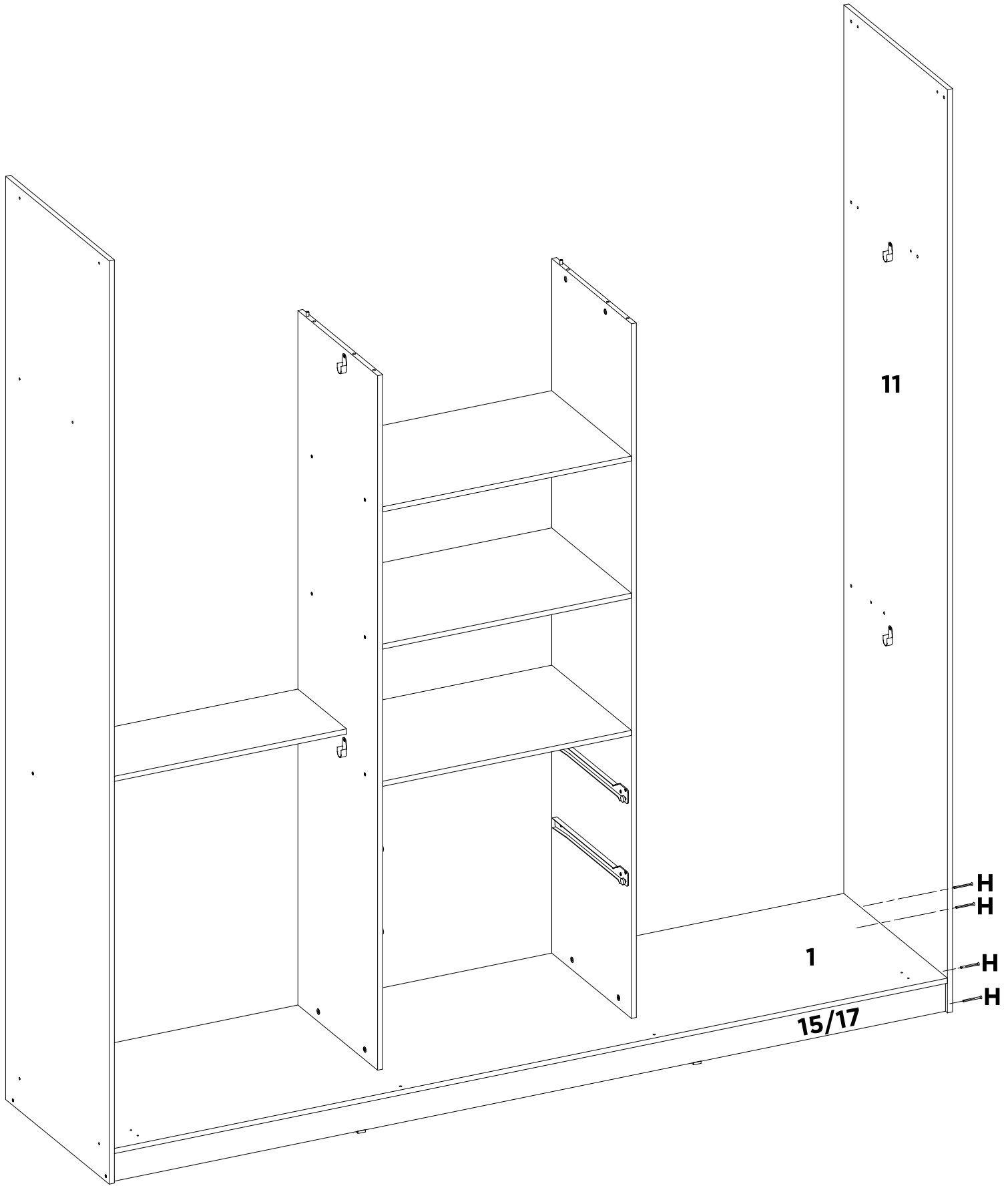

H	-	-	-	-	-	-	-
X4	-	-	-	-	-	-	-

18

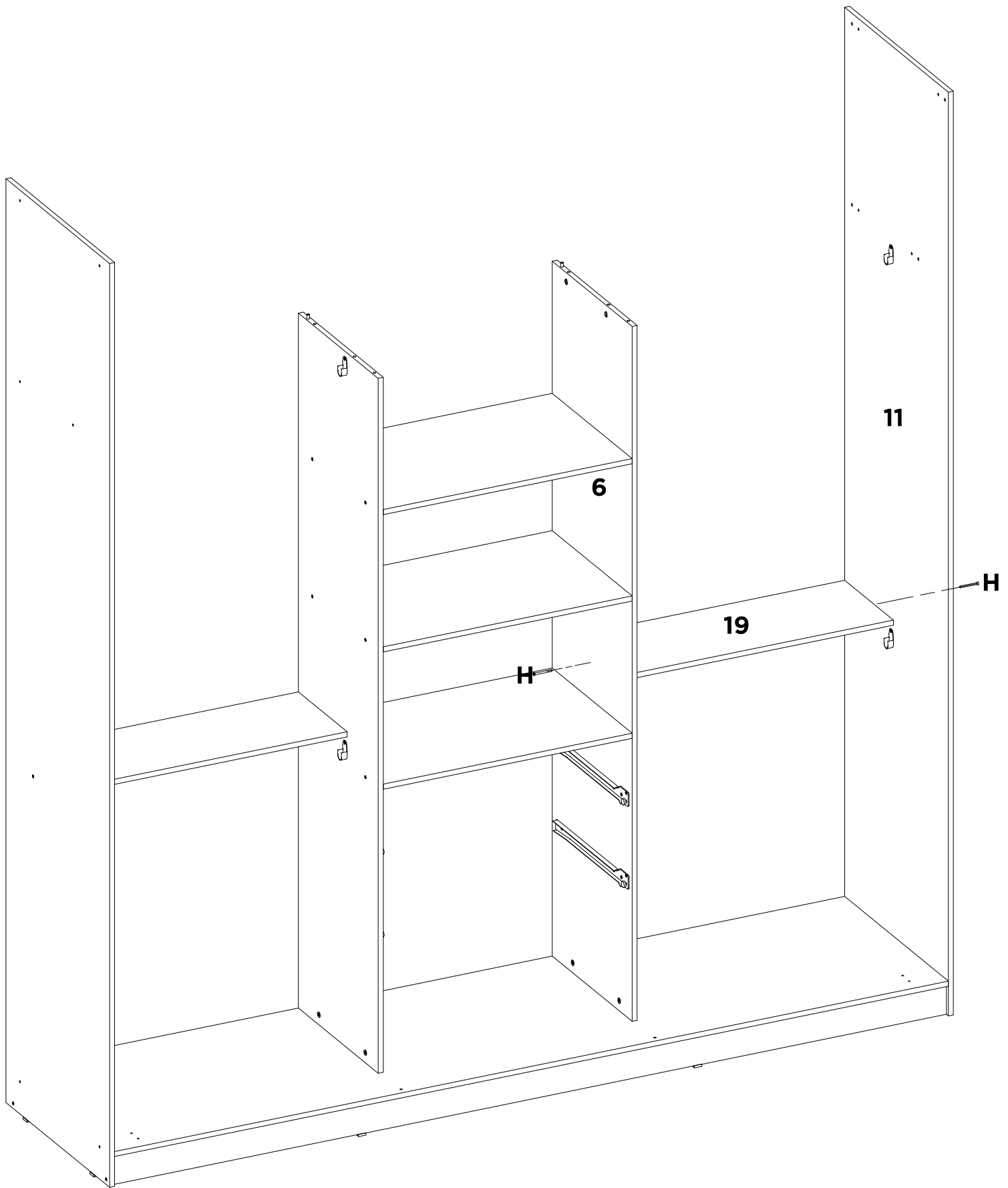

H	-	-	-	-	-	-	-
X2	-	-	-	-	-	-	-

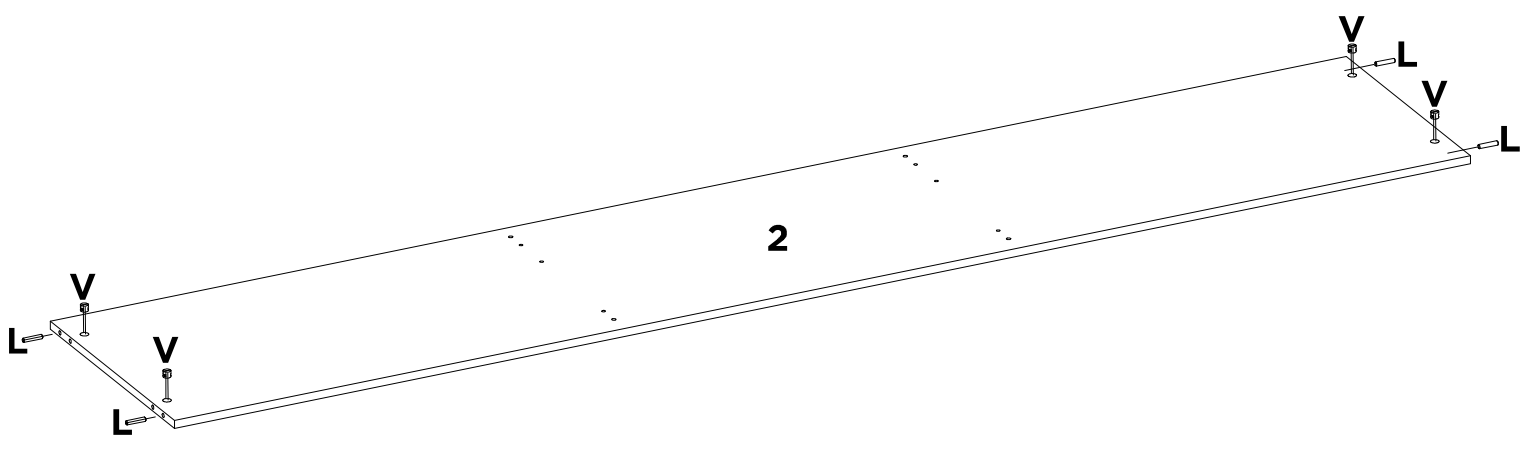

L	V	-	-	-	-	-	-
X4	X4	-	-	-	-	-	-

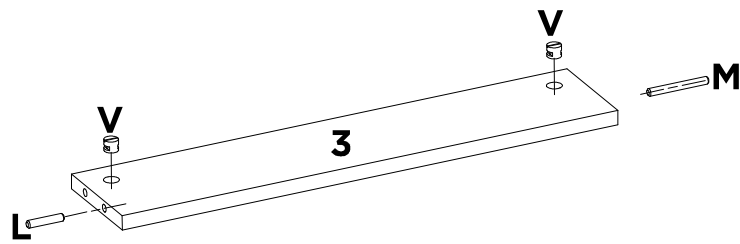

L

X2

M

X2

V

X4

-

-

-

-

-

-

-

-

-

-

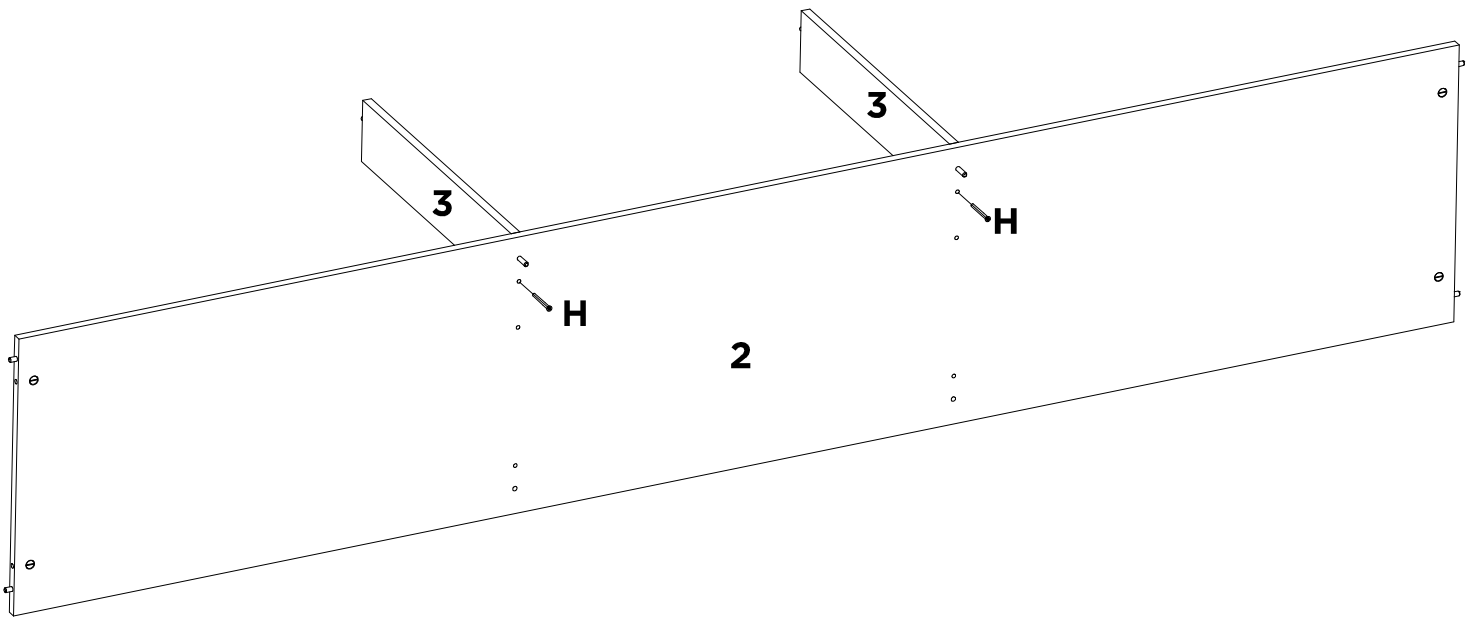

H	-	-	-	-	-	-	-
X2	-	-	-	-	-	-	-

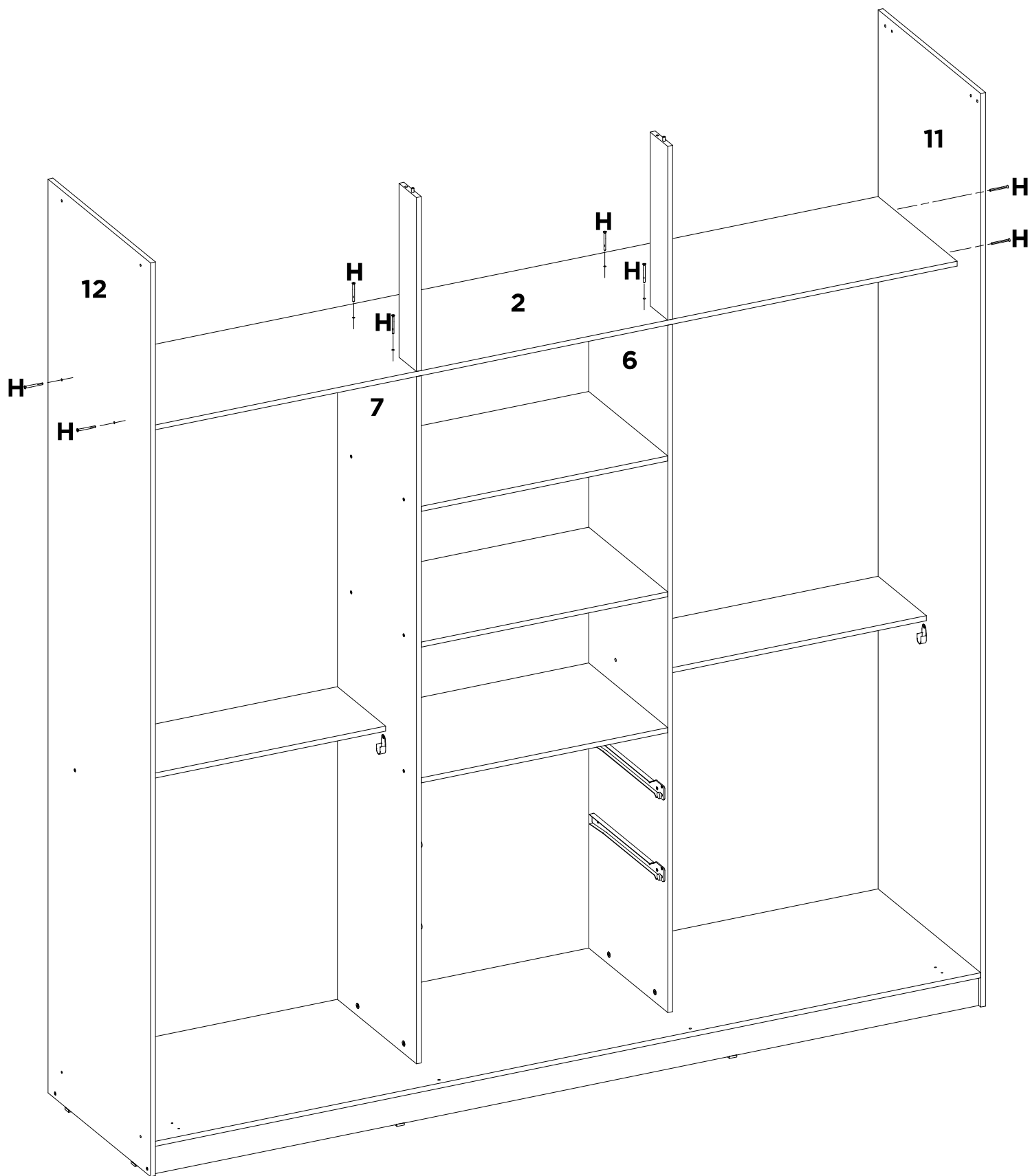

H	-	-	-	-	-	-	-
X8	-	-	-	-	-	-	-

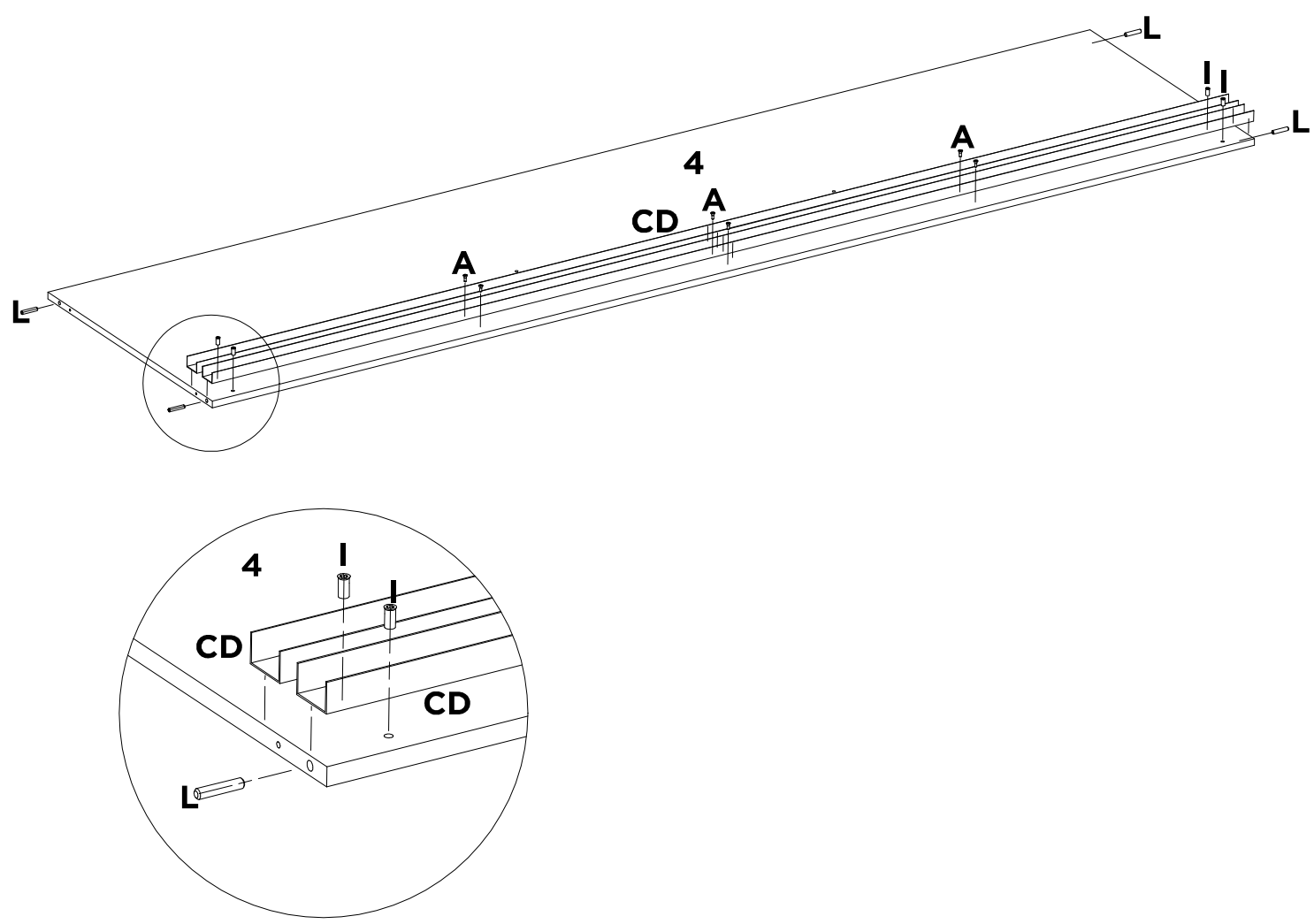

A	CD	I	L	-	-	-	-
X6	X2	X4	X4	-	-	-	-

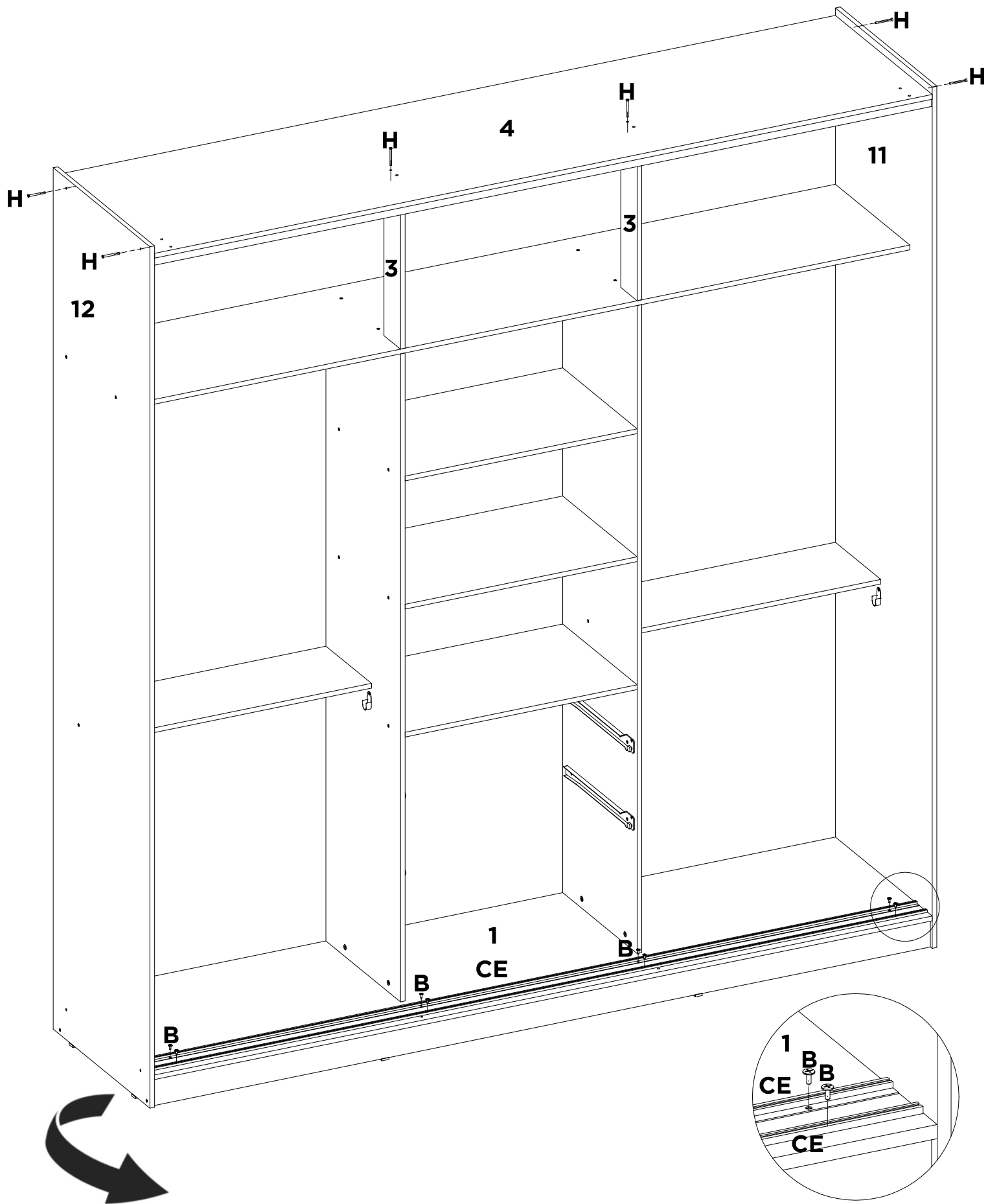

B	CE	H	-	-	-	-	-
X8	X2	X6	-	-	-	-	-

25

2x

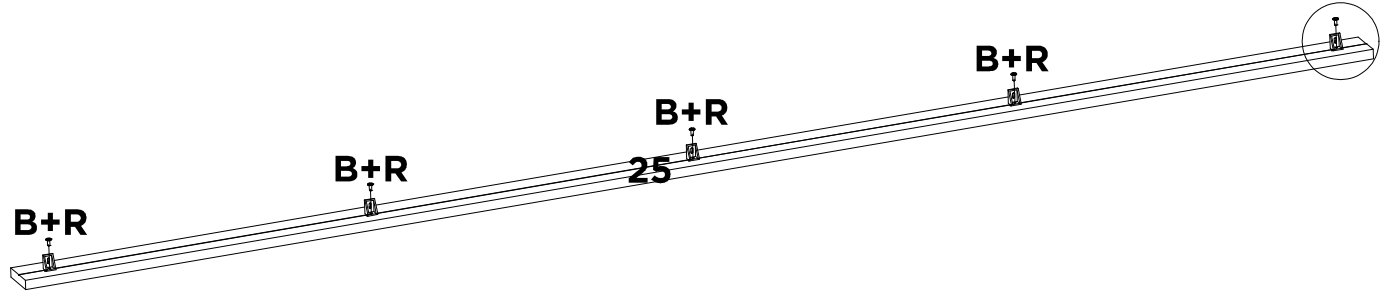
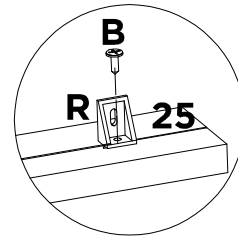

B	R	-	-	-	-	-	-
X10	X10	-	-	-	-	-	-

25A

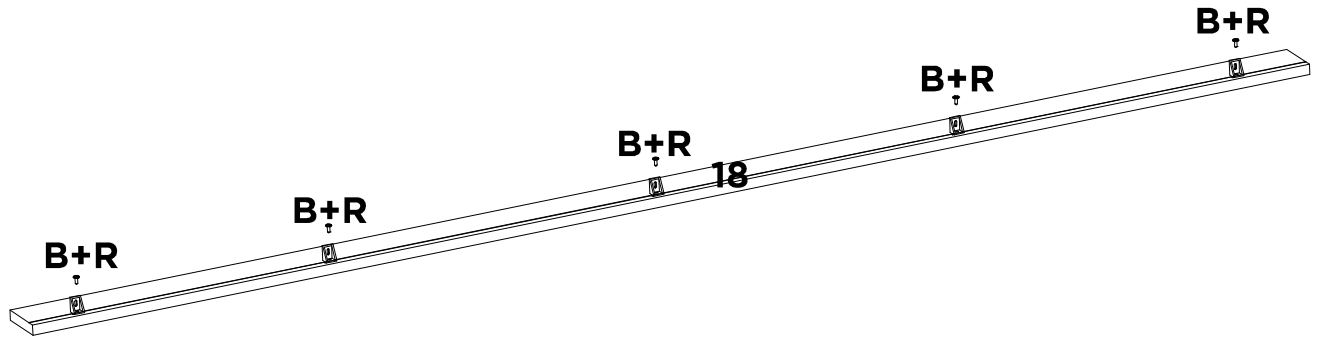

B	R	-	-	-	-	-	-
X5	X5	-	-	-	-	-	-

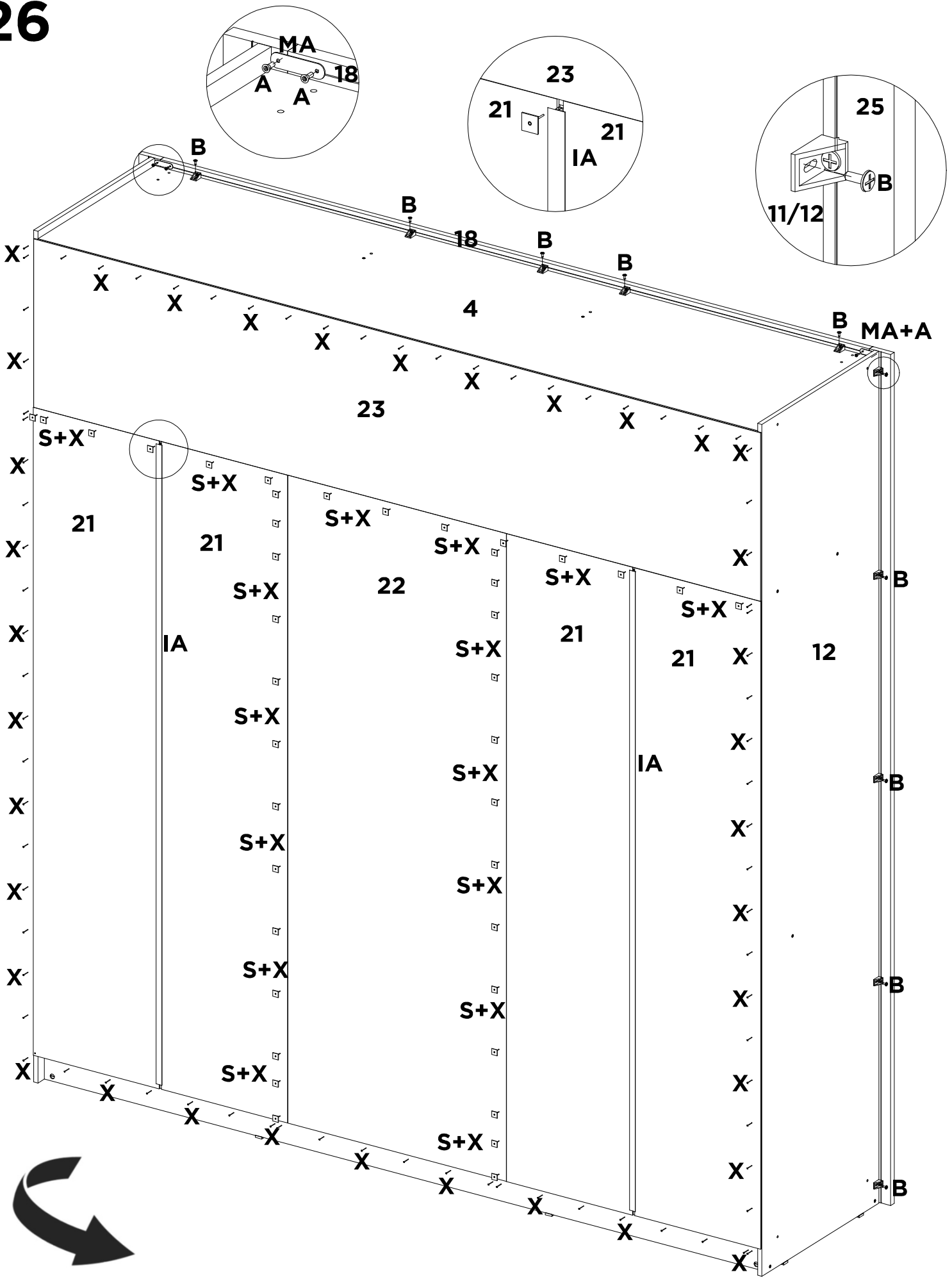

A	B	IA	MA	S	X	-	-
X4	X15	X2	X2	X40	X150	-	-

27

2x

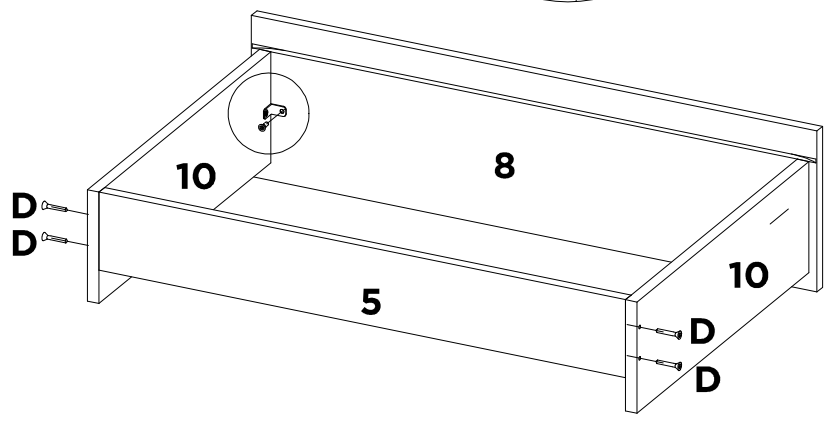
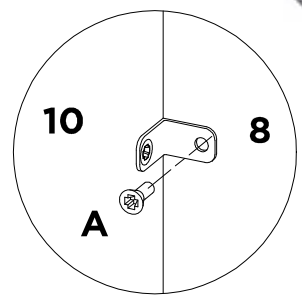
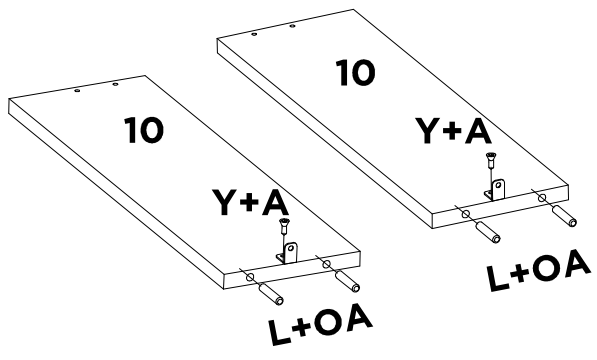

A	D	L	OA	Y	-	-	-
X8	X8	X8	X1	X4	-	-	-

27A

2x

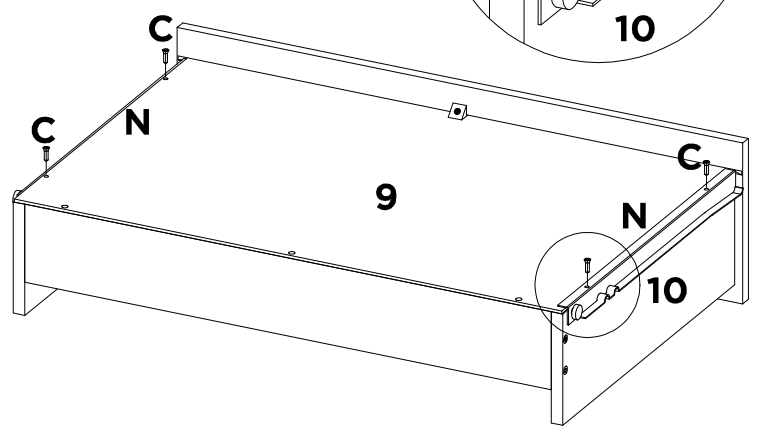
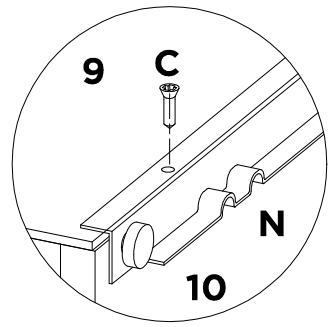
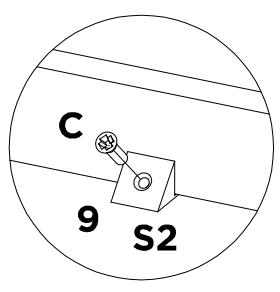
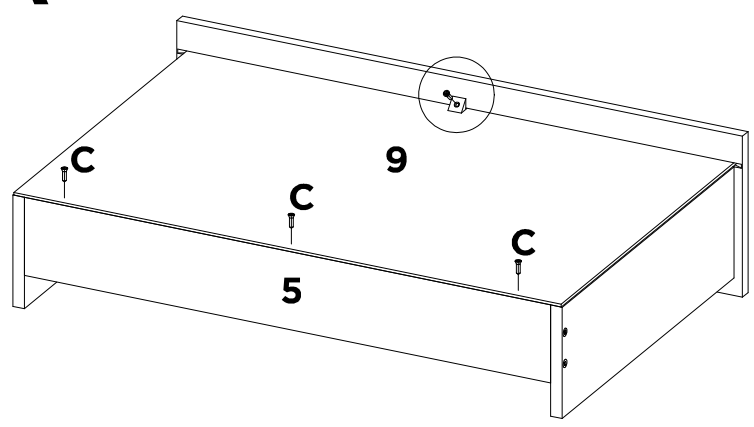

C	N	S2	-	-	-	-	-
X16	X4	X2	-	-	-	-	-

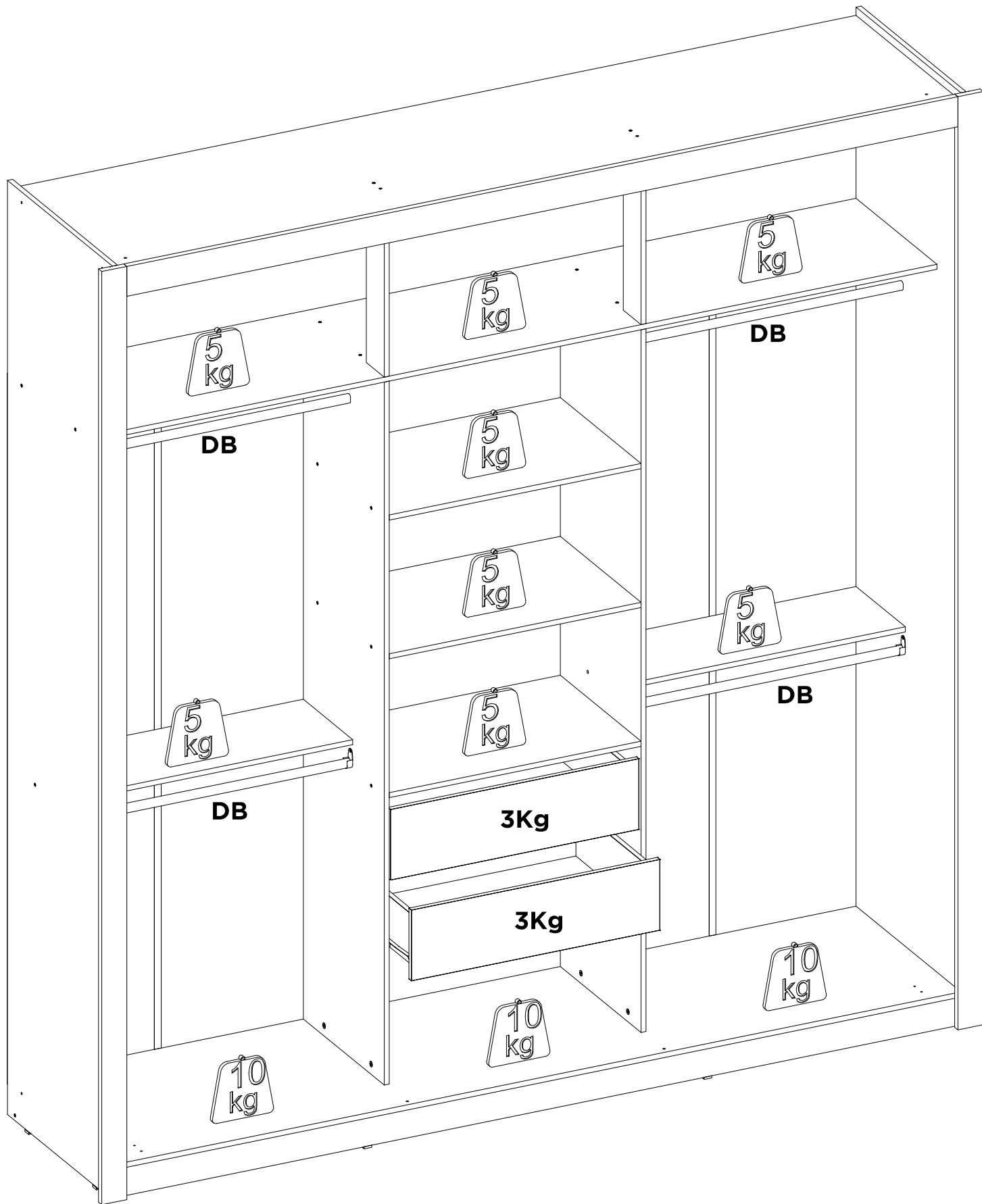

DB	-	-	-	-	-	-	-	-
X4	-	-	-	-	-	-	-	-

29

2x

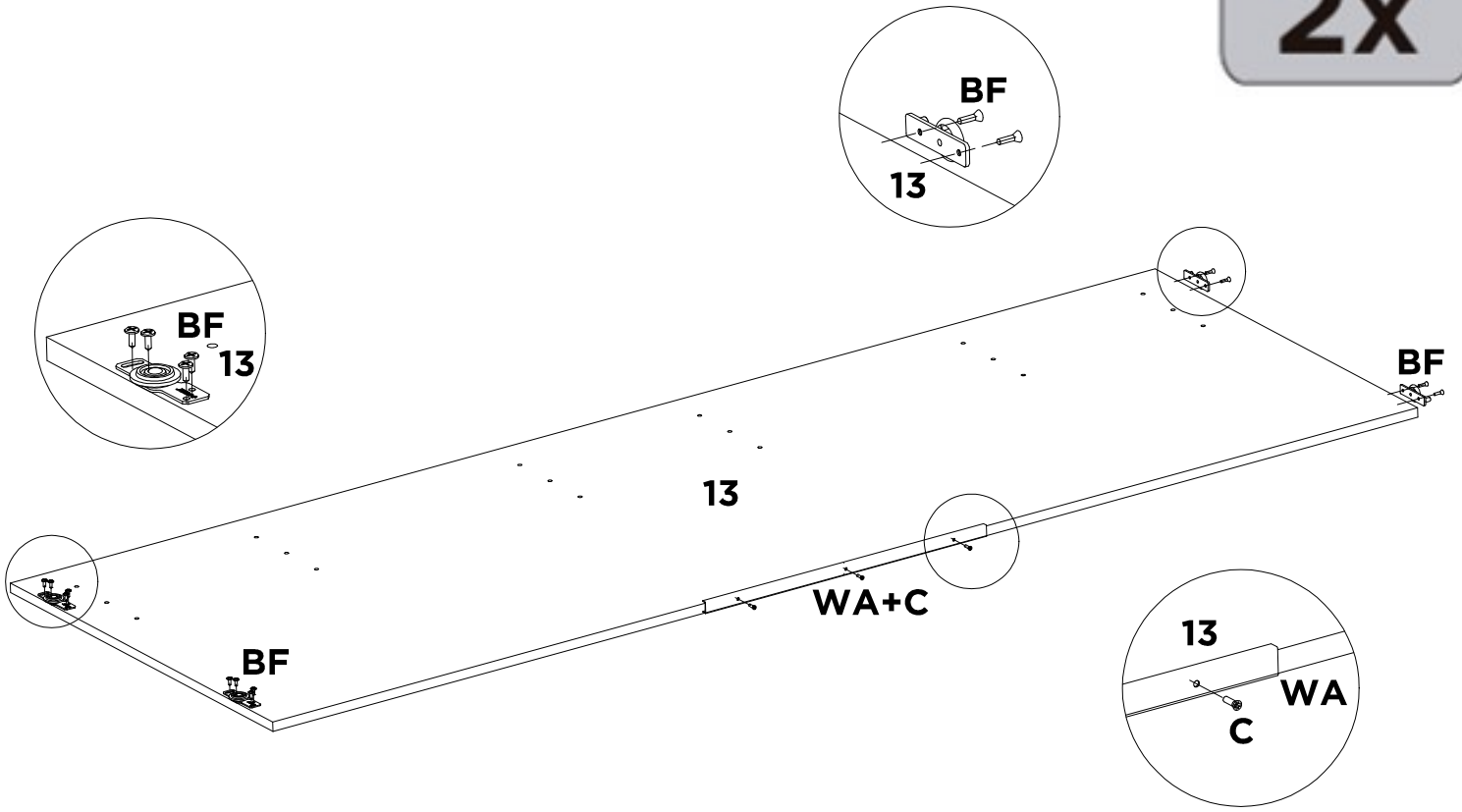

BF	C	WA	-	-	-	-	-
X1	X6	X2	-	-	-	-	-

29A

2x

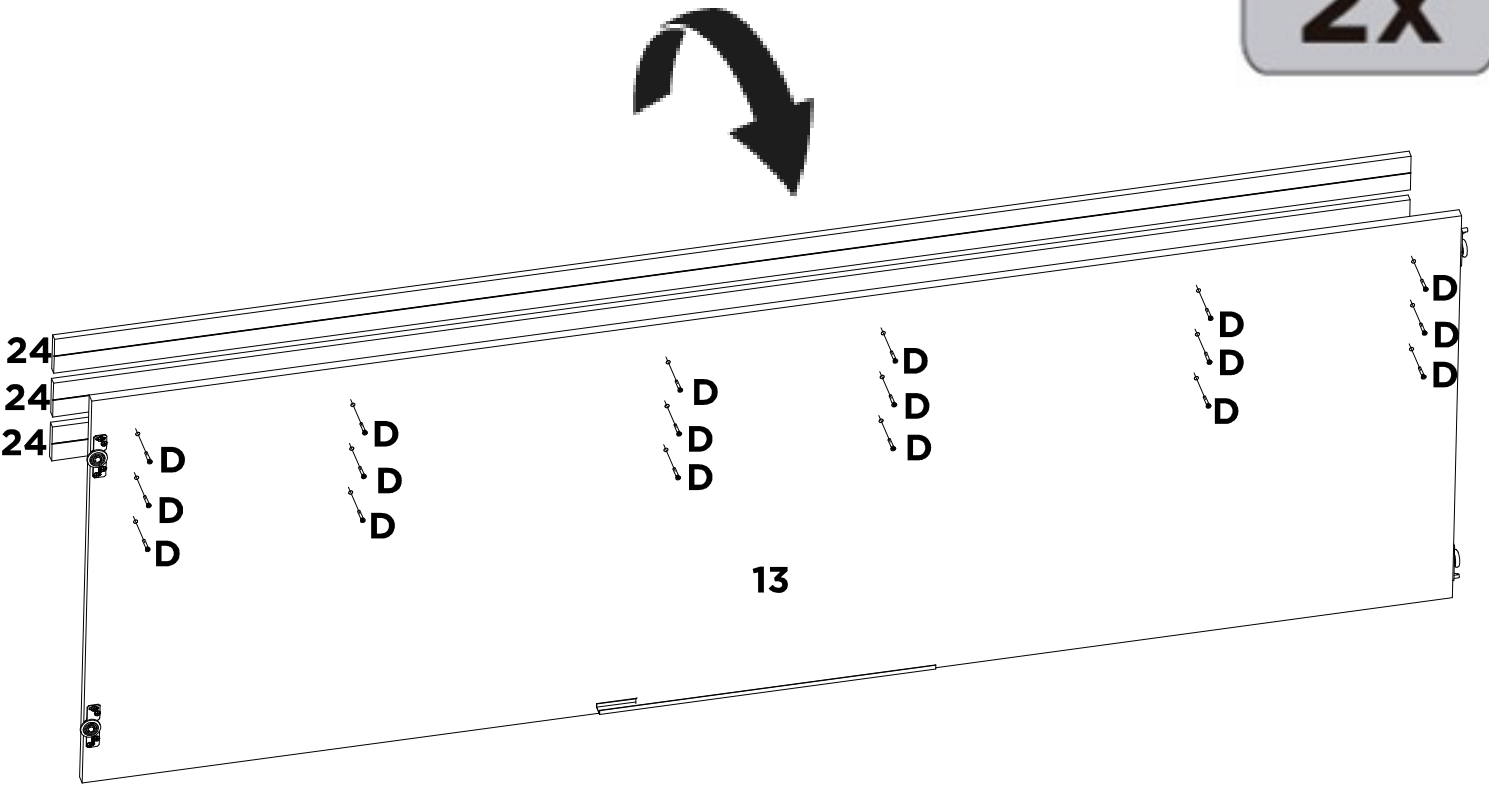

D	-	-	-	-	-	-	-
X36	-	-	-	-	-	-	-

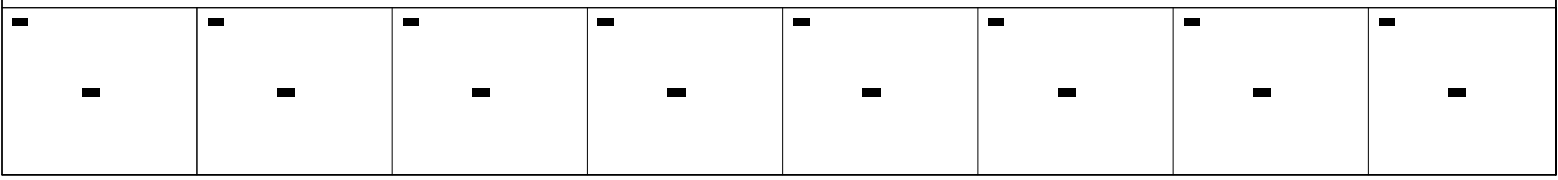
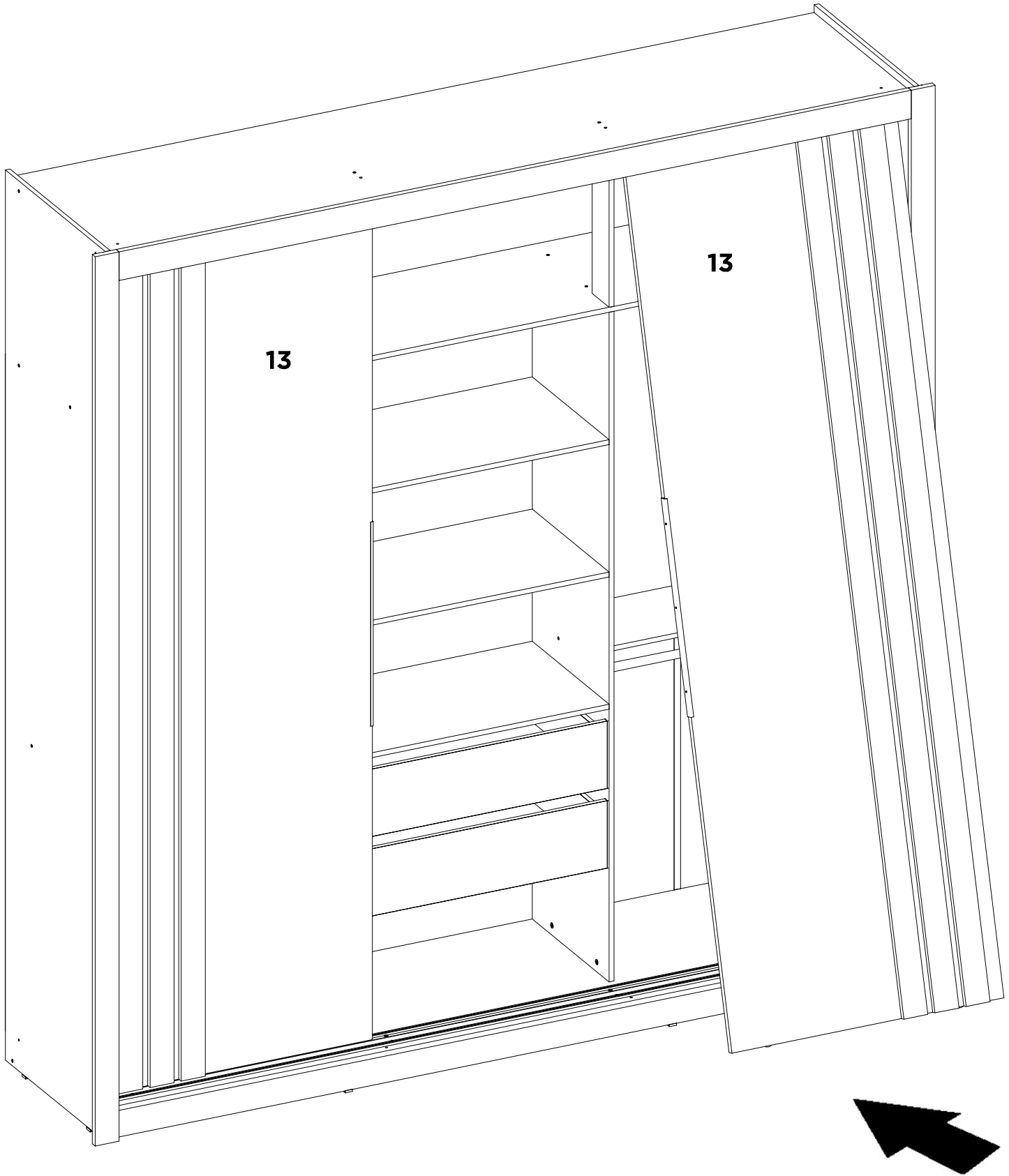

31

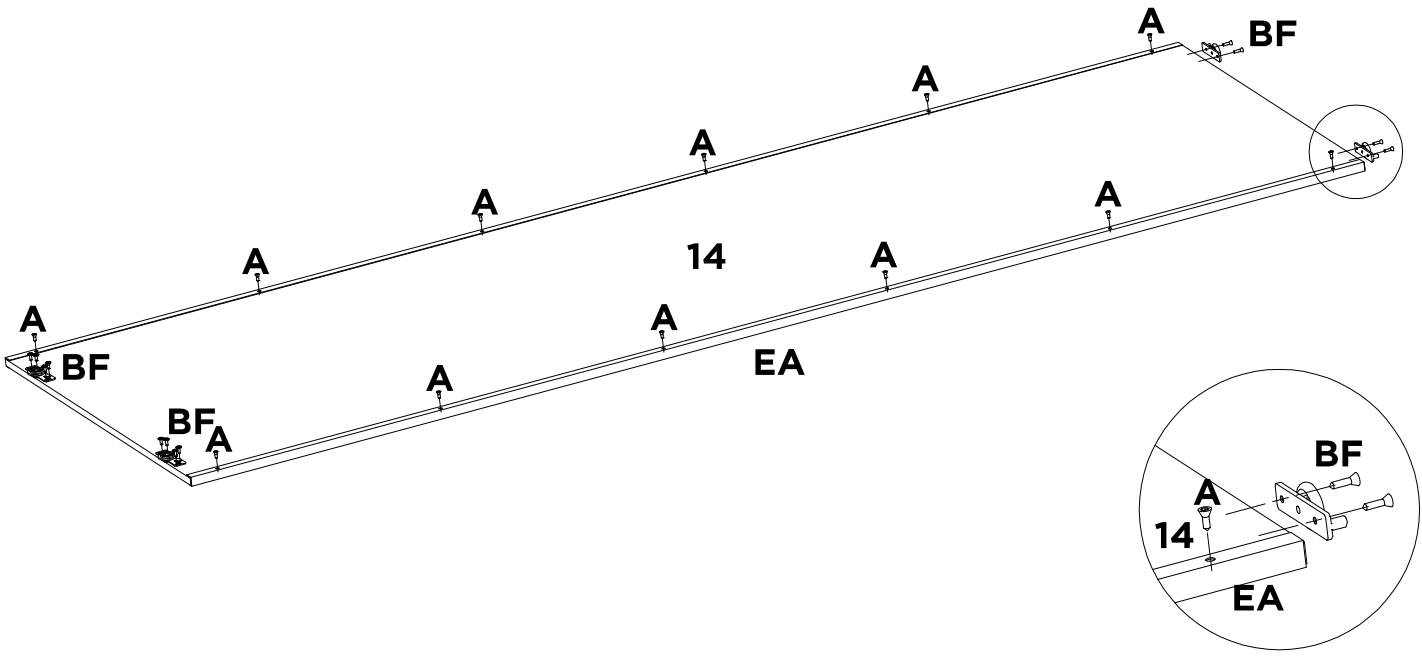

A	BF	EA	-	-	-	-	-
X12	X1	X2	-	-	-	-	-

31A

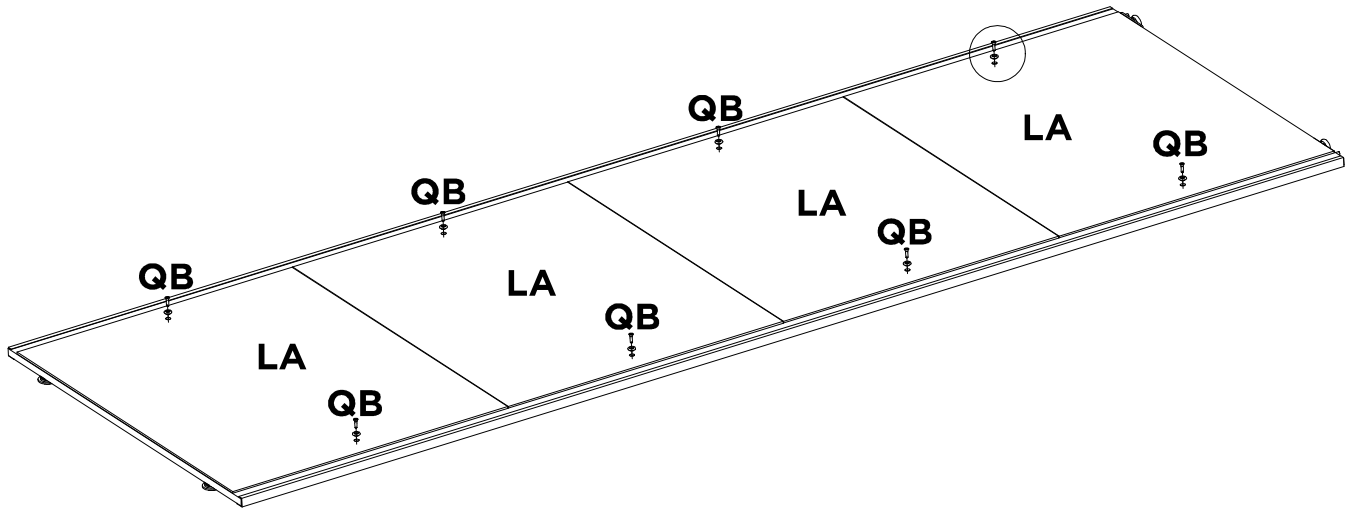
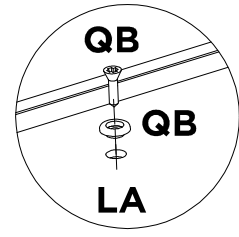

QB	LA	-	-	-	-	-	-
X8	X4	-	-	-	-	-	-

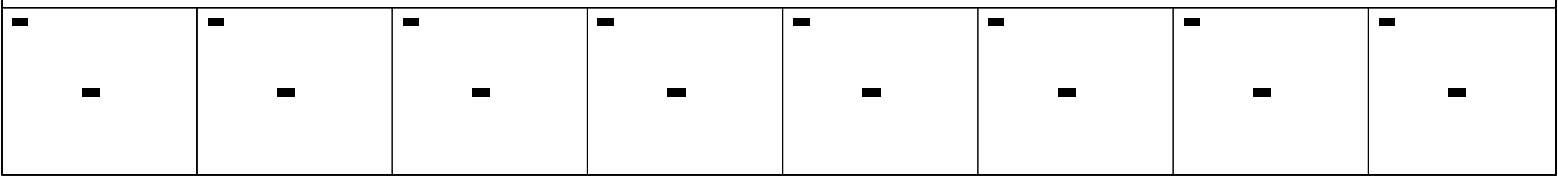
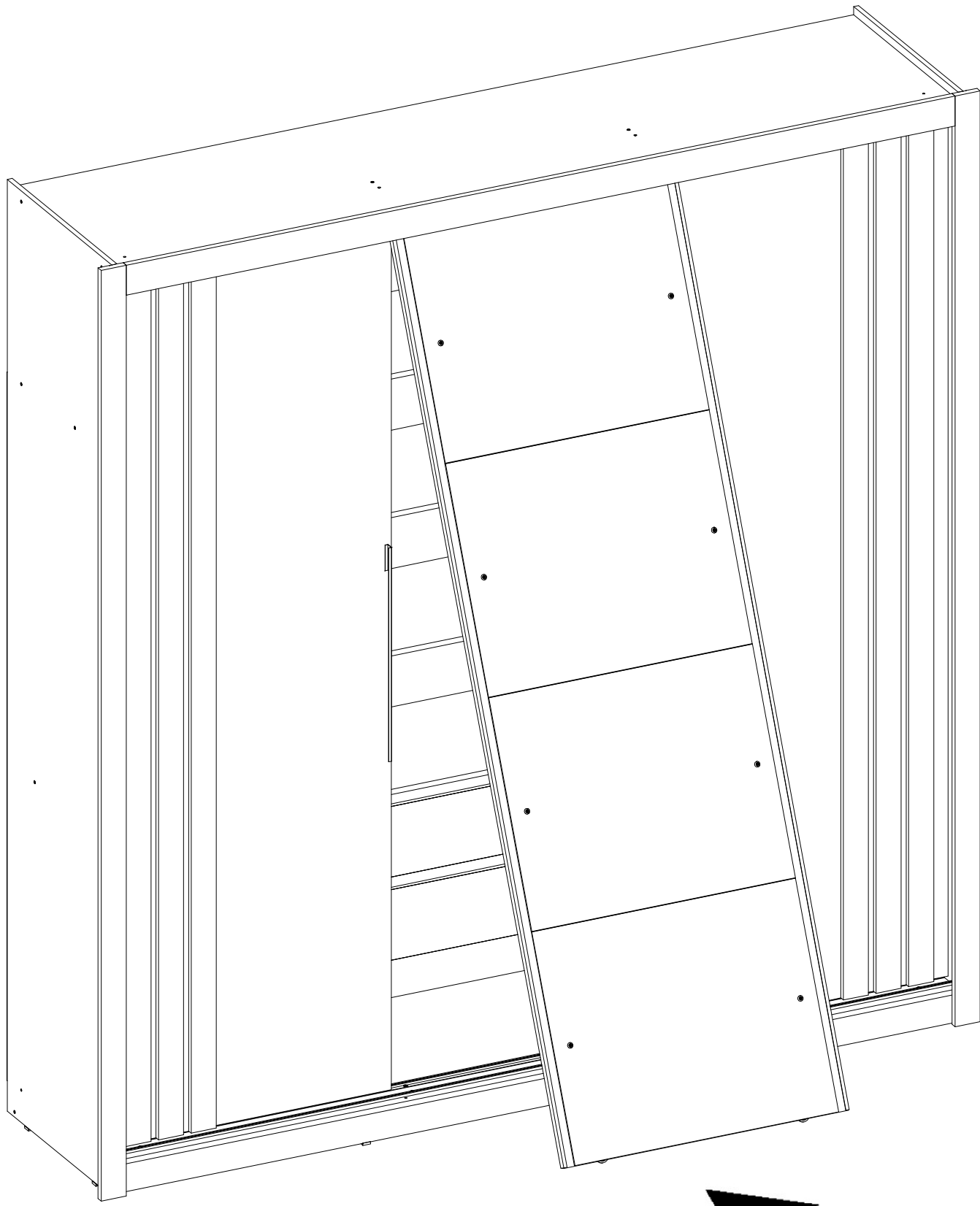

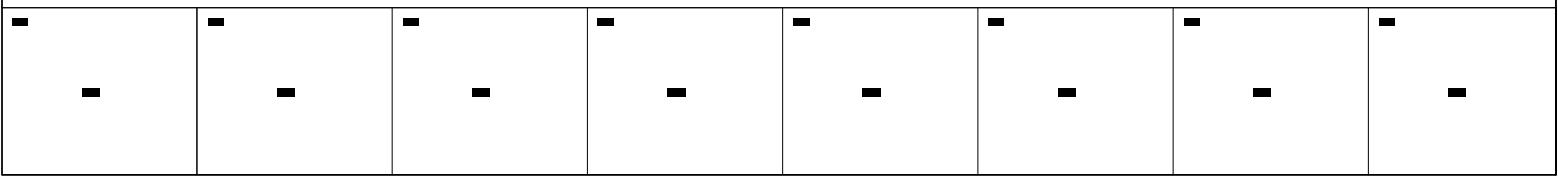
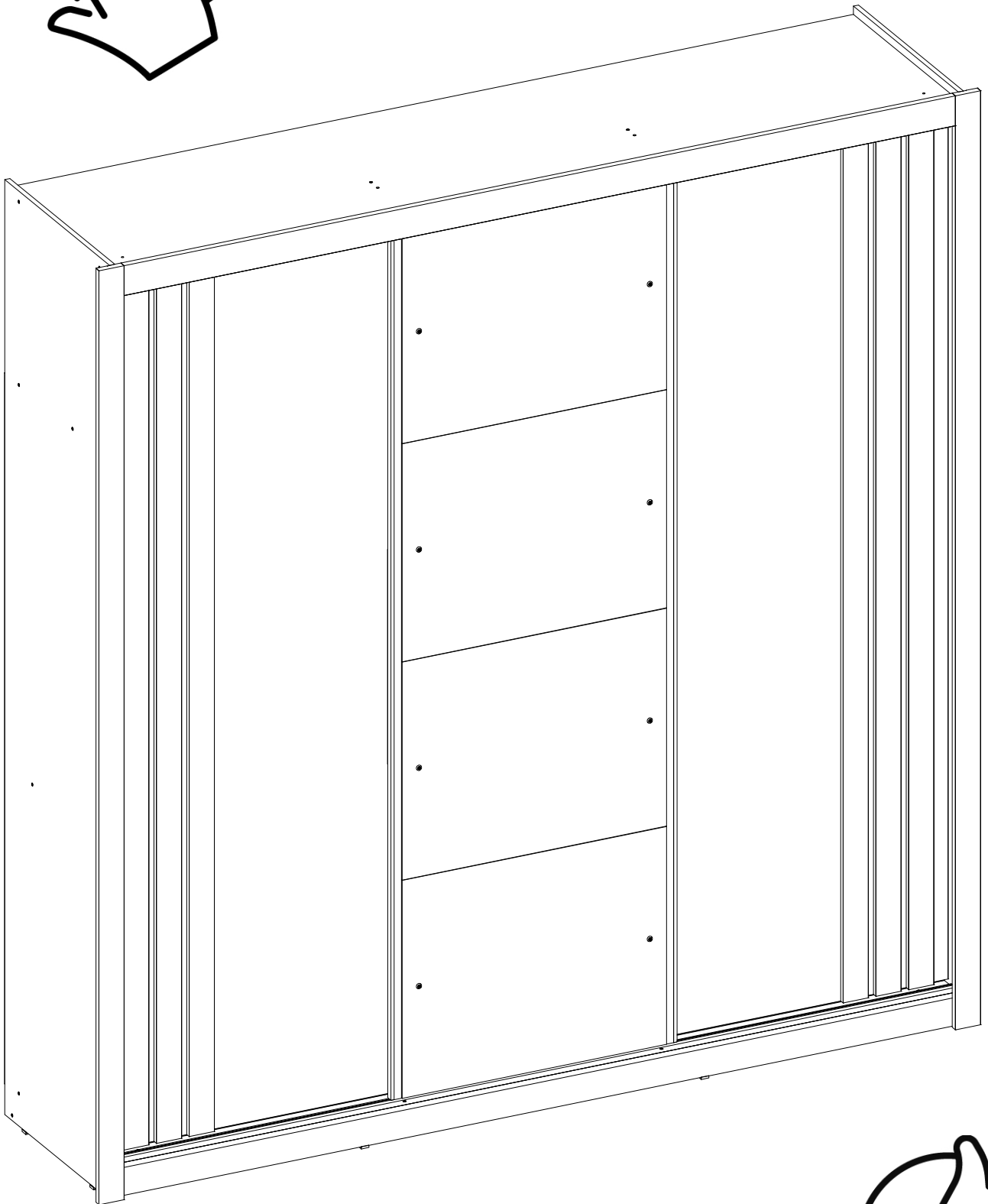



DemóBILE