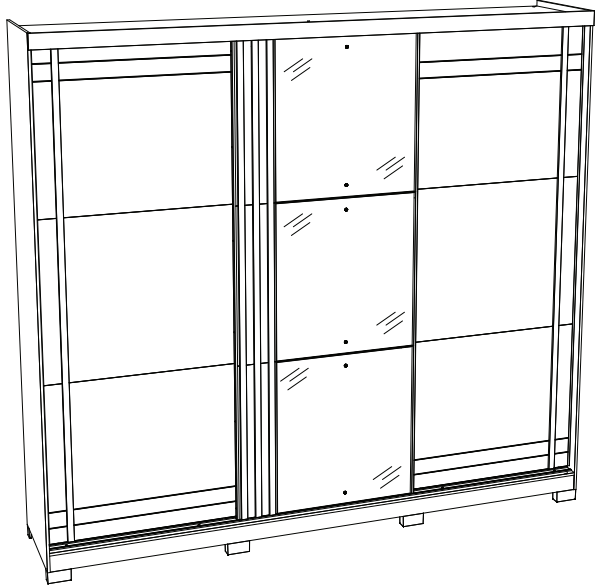
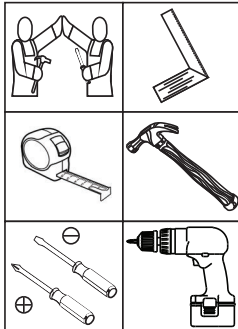

HENNInd. e Com. de Móveis Henn
Mondaí - SC - Brasil

☎ +55 49 3674.3500

📱 @moveishenn
www.henn.com.br**INSTRUÇÕES DE
MONTAGEM**INSTRUCCIONES DE MONTAJE
ASSEMBLY INSTRUCTIONS**Roupeiro Fazano 3 Portas Deslizantes | Armario Fazano 3 Puertas Deslizantes
Wardrobe Fazano 3 Sliding Doors**D324-127 Nature/Off White
D324-216 Nature/Verde HP**Requisitos para montagem
Requisitos para la montaje
Assembly Requirements**

Imagens meramente ilustrativas,
não acompanha o produto.
Imágenes ilustrativas, no incluidas
con el producto.
Illustrative images, not included
with the product.

AVISO

Para limpeza de seu móvel, use uma flanela seca ou umedecida, e não utilize produtos químicos que possam danificar seu produto.

SISTEMA DE MONTAGEM

O sistema de montagem dos produtos, funciona de acordo com a ordem crescente dos números indicados no desenho. Ex: 01, 02, 03, 04... até a conclusão da montagem.

ASSISTÊNCIA TÉCNICA

Para solicitação de Assistência Técnica você consumidor deverá entrar em contato com o Lojista o qual você realizou a compra deste produto e solicitar a assistência técnica das peças avariadas. A garantia abrange todas as peças, partes e componentes que eventualmente venham apresentar defeito de fabricação no prazo de 03 (três) meses, contando a partir da entrega do produto ao consumidor, mediante nota fiscal de compra. Se houver qualquer alteração na estrutura do produto ou ocorrer defeito por negligência do montador/consumidor em relação a instrução de montagem e manuseio, não será fornecido assistência técnica gratuita.

ADVERTENCIA

Para limpeza de su móvil, use una flanela seca o húmeda, y no utilice productos químicos que puedan dañar su producto.

SISTEMA DE MONTAJE

El sistema de montaje de los productos funciona de acuerdo con el orden creciente de los números indicados en el dibujo. Ej.: 01, 02, 03, 04... hasta la conclusión del montaje.

ASISTENCIA TÉCNICA

Para solicitar Asistencia Técnica, el consumidor debe comunicarse con el Comercio que usted realizó la compra de este producto y solicita asistencia técnica para las partes dañadas. La garantía cubre todas las partes, piezas y componentes que eventualmente puedan presentar defecto de fabricación en el plazo de 03 (tres) meses, contados a partir de la entrega del producto al consumidor, mediante factura de compra. Si se produce algún cambio en la estructura del producto o se produce un defecto por negligencia del montador/consumidor en relación con las instrucciones de montaje y manipulación, no se prestará asistencia técnica gratuita.

NOTICE

To clean your furniture, use a dry or wet cloth, and do not use chemicals that may damage your product.

ASSEMBLY SYSTEM

The products' assembly system works according to the increasing order of the indicated numbers. For example: 01, 02, 03, 04 ... to the end of the assembly.

TECHNICAL ASSISTANCE

To request Technical Assistance, the consumer must contact the retailer from whom you purchased this product and request technical assistance for the damaged parts. The warranty covers all parts, parts and components that may eventually present a manufacturing defect within a period of 03 (three) months, counting from the delivery of the product to the consumer, by means of a purchase invoice. If there is any change in the structure of the product or defect occurs due to negligence of the assembler/consumer in relation to the assembly and handling instruction, free technical assistance will not be provided.

ACESSÓRIOS | ACCESORIOS | ACCESSORIES

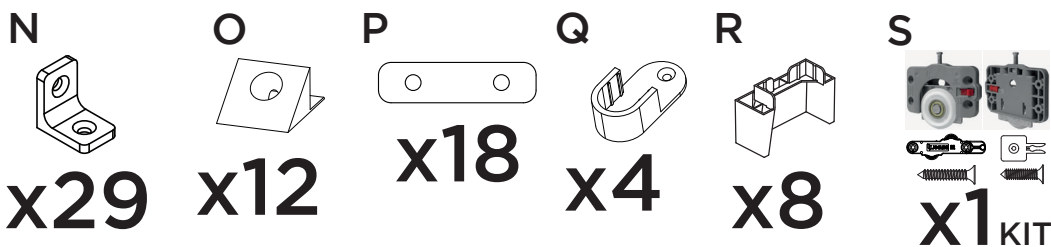
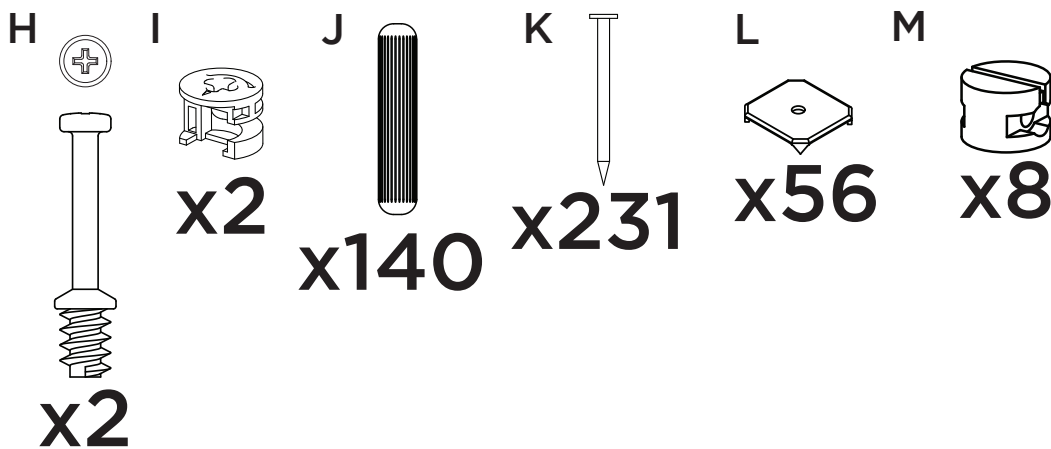
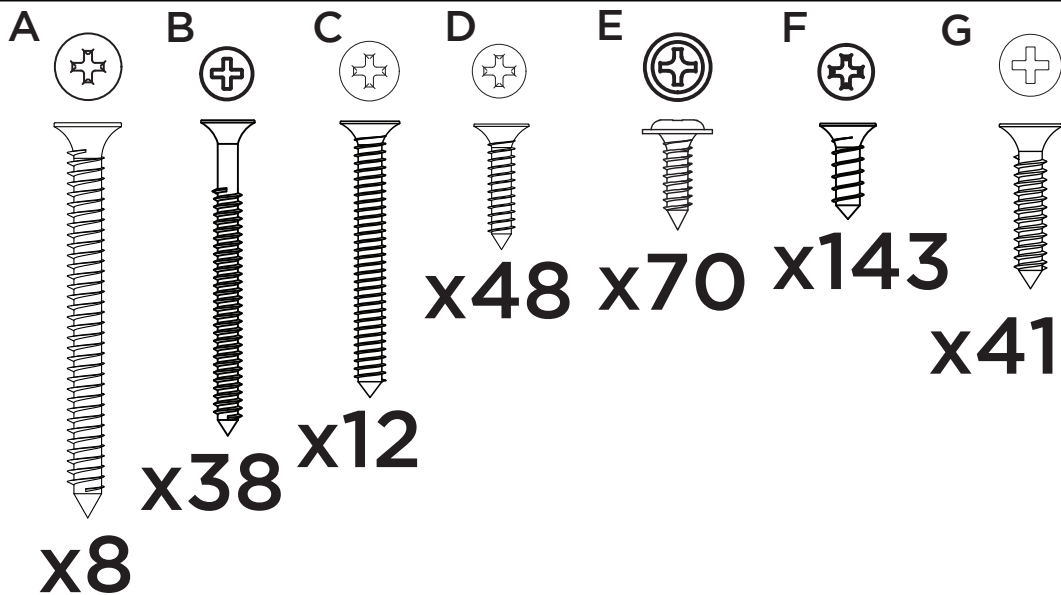

Parafusos em escala
Tornillos escalados
Scaled screws **1:1**

ACESSÓRIOS | ACCESORIOS | ACCESSORIES

T



x2

U



x6 PAR

V

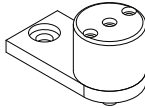

x12

W



x3

X



x12

Y



x6

Z



x1

AA



x1

AB

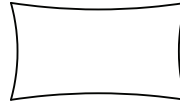

x3

AC

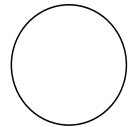

x4

AD



x34

AE



x36

AF

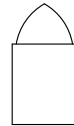

x3

AG

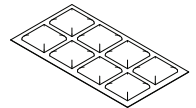

x24

AH



x1

AI

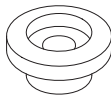

x6

AJ



x6

LISTA DE PEÇAS | LISTA DE PIEZAS | LIST OF PIECES ITM/D324-



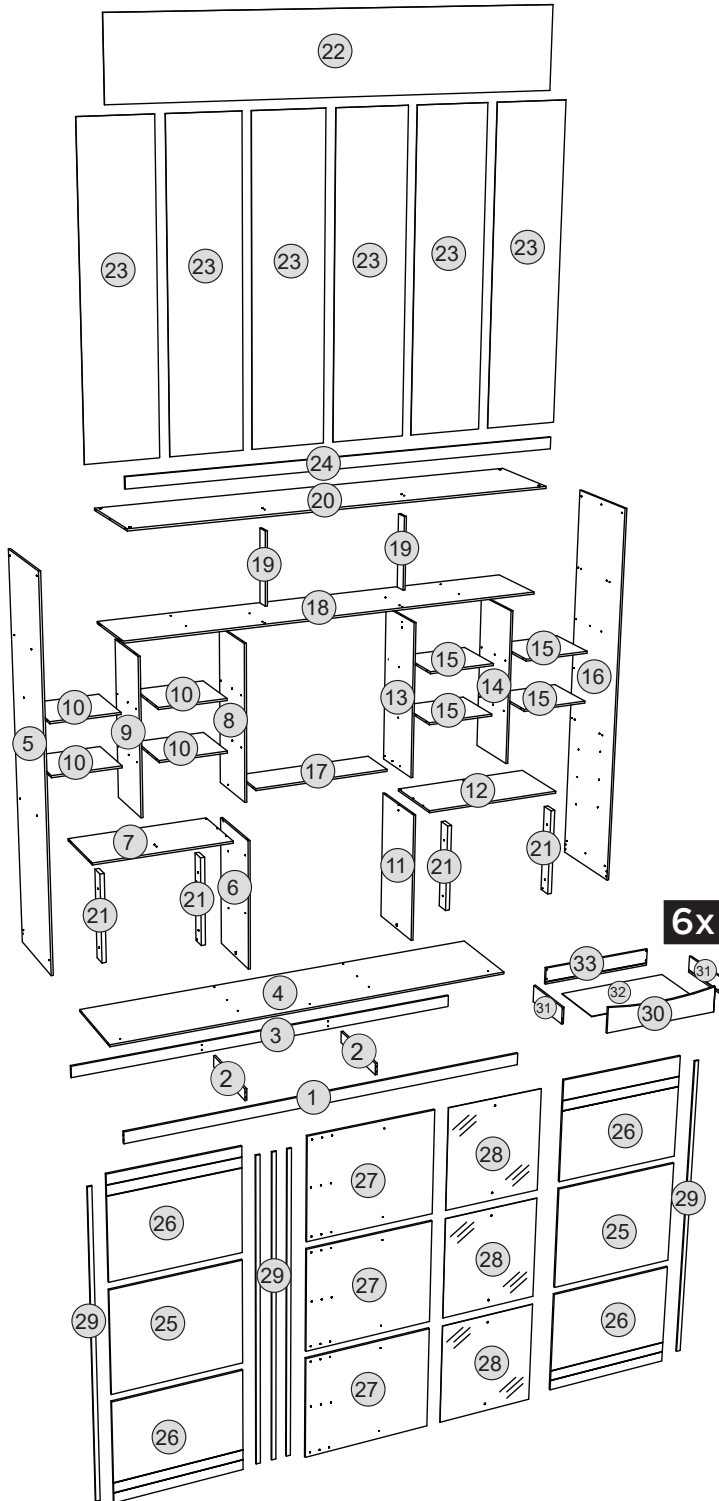

Item	Caixa Caja Box	Qty Ctd Qty	Descrição Descripción Description	Dimensões (mm) Dimensiones (mm) Dimensions (mm)		
				Comprimento Largo Length	Largura Ancho Width	Espessura Grosor Thickness
1	3/4	1	RODAPÉ FRONTAL FALDÓN DELANTERO FRONT SKIRTING	2463	73	12
2	1/4	2	TRAVESSA DO RODAPÉ PLACA DE RODAPIÉ SKIRTING PLATE	470	73	12
3	3/4	1	RODAPÉ TRASEIRO REPOSAPIÉS TRASERO BACK FOOTBOARD	2463	73	12
4	3/4	1	BASE BASE BASE	2463	500	12
5	1/4	1	LATERAL ESQUERDA LATERAL IZQUIERDA LEFT SIDE	2250	500	12
6	2/4	1	DIVISÃO INFERIOR ESQUERDA DIVISIÓN INFERIOR IZQUIERDA BOTTOM LEFT DIVISION	775	400	12
7=12	2/4	1	TAMPO DAS GAVETAS SUPERIOR DEL CAJÓN DRAWER TOP	825	400	12
8	2/4	1	DIVISÃO SUPERIOR ESQUERDA DIVISIÓN SUPERIOR IZQUIERDA UPPER LEFT DIVISION	914	355	12
9=14	2/4	1	DIVISÃO SUPERIOR DIVISIÓN DERECHA RIGHT DIVISION	914	355	12
10=15	1/4	4	PRATELEIRA ESTANTE SHELF	400	350	12
11	2/4	1	DIVISÃO INFERIOR DIREITA DIVISIÓN INFERIOR DERECHA LOWER RIGHT DIVISION	775	400	12
12=7	2/4	1	TAMPO DAS GAVETAS SUPERIOR DEL CAJÓN DRAWER TOP	825	400	12
13	2/4	1	DIVISÃO SUPERIOR DIREITA DIVISIÓN SUPERIOR DERECHA UPPER RIGHT DIVISION	914	355	12
14=9	2/4	1	DIVISÃO SUPERIOR DIVISIÓN DERECHA RIGHT DIVISION	914	355	12
15=10	1/4	4	PRATELEIRA ESTANTE SHELF	400	350	12
16	1/4	1	LATERAL DIREITA LADO DERECHO RIGHT SIDE	2250	500	12
17	2/4	1	PRATELEIRA DO CALCEIRO ESTANTE DE CALCEIRO CALCEIRO'S SHELF	813	250	12
18	3/4	1	CHÃO DO MALEIRO REPISA SUPERIOR FLOOR OF MALEIRO	2463	410	12
19	1/4	2	RIPA DO MALEIRO TRAVESAÑO SUPERIOR MALEIRO'S LATH	414	73	12
20	3/4	1	TAMPO TAPA TOP	2463	500	12
21	3/4	4	RIPA LATERAL RIPA LATERAL SIDE CLAPBOARD	525	80	25
22	3/4	1	FUNDO SUPERIOR FONDO TOP TOP FUND	2481	431	3
23	1/4	6	FUNDO FONDO BOTTOM	1717	410	3
24	3/4	1	CHAPÉU SOMBRERO HAT	2485	65	12
25	4/4	2	PAINEL PANEL PANEL	825	697	12
26	4/4	4	PAINEL INFERIOR SUPERIOR PANEL INFERIOR SUPERIOR TOP BOTTOM PANEL	825	697	12
27	4/4	3	PAINEL ESPELHO PANEL ESPEJO MIRROR PANEL	840	697	12
28	3/4	5	APLIQUE APLICAR APPLY	2089	28	9
29	4/4	3	ESPELHO ESPEJO MIRROR	690	630	3
30	1/4	6	FRENTE DE GAVETA FRENTE DE CAJÓN FRONT OF DRAWER	755	170	12
31	1/4	12	LADO DE GAVETA LADO DEL CAJÓN SIDE OF DRAWER	350	110	12
32	1/4 e 2/4	6	FUNDO DE GAVETA RECORTADO FONDO DEL CAJÓN RECORTADO CROPPED DRAWER BOTTOM	725	361	3
33	1/4	6	RIPA DE TRÁS MALLA DETRÁS REAR LATH	738	110	12

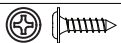

PEÇAS REQUERIDAS

1	RODAPÉ FRONTAL	x1
2	TRAVESSA DO RODAPÉ	x2
3	RODAPÉ TRASEIRO	x1
5	LATERAL ESQUERDA	x1
16	LATERAL DIREITA	x1
19	RIPA DO MALEIRO	x2

ACESSÓRIOS REQUERIDOS

E		16
J		20
N		10
V		06

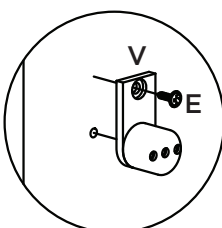
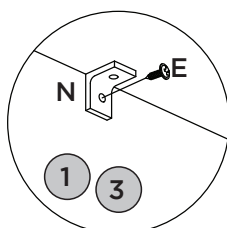
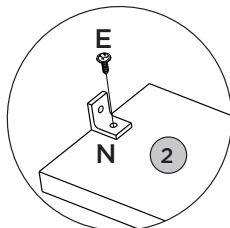
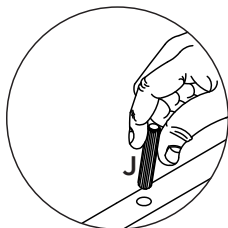
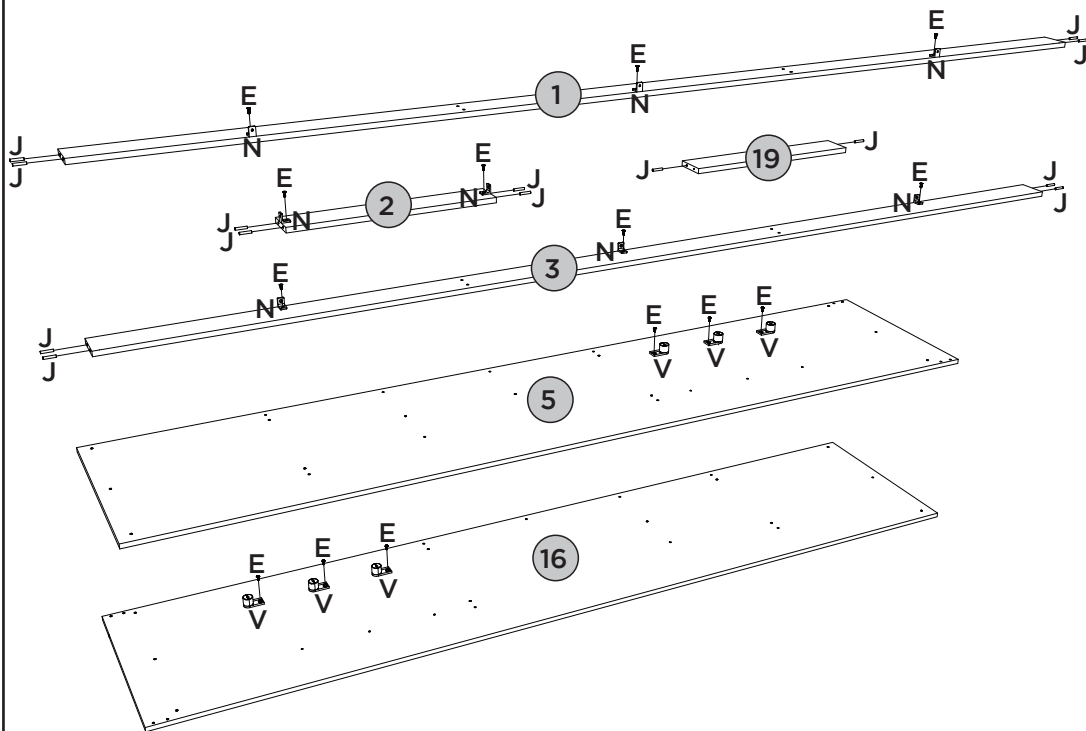
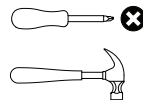

FERRAMENTAS NECESSÁRIAS



PEÇAS REQUERIDAS

4	BASE	x1
18	CHÃO DO MALEIRO	x1
20	TAMPO	x1

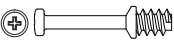
ACESSÓRIOS REQUERIDOS

J		08
H		02
M		08



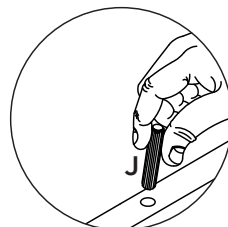
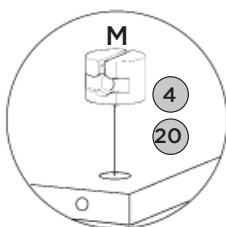
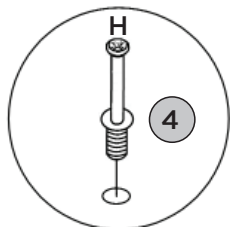
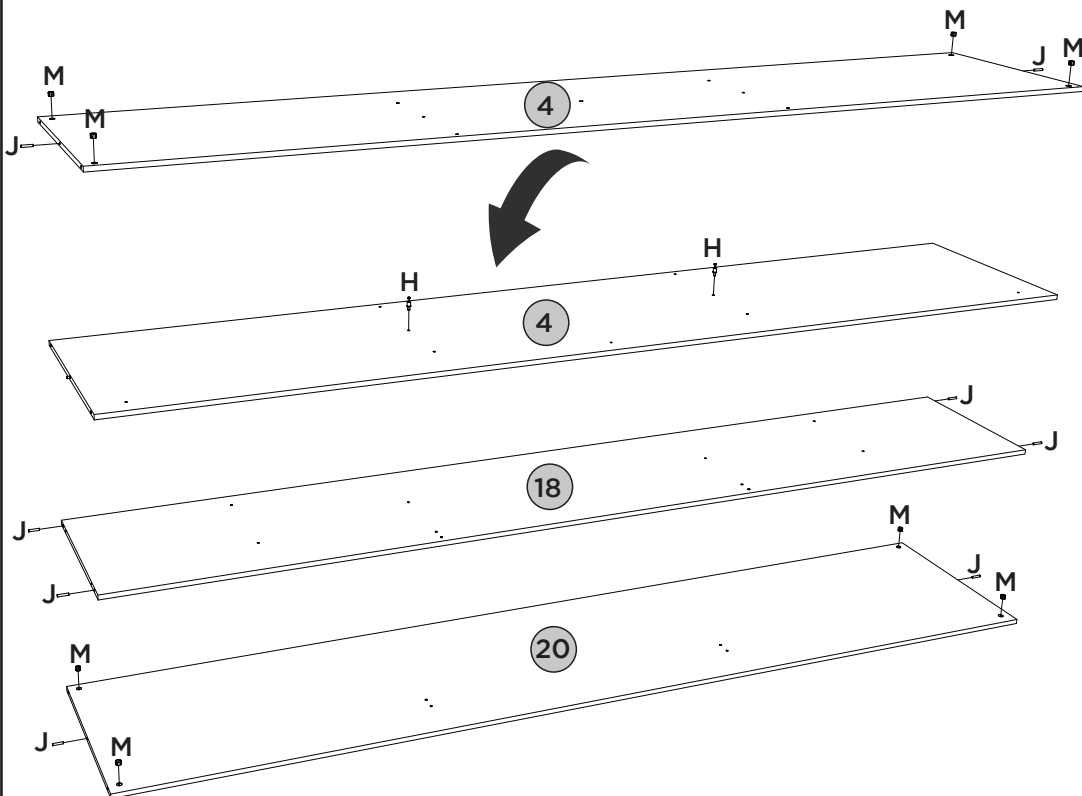
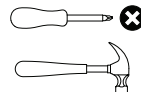

FERRAMENTAS NECESSÁRIAS



PEÇAS REQUERIDAS

6	DIVISÃO INFERIOR ESQUERDA	x1
7=12	TAMPO DAS GAVETAS	x2
8	DIVISÃO SUPERIOR ESQUERDA	x1
9=14	DIVISÃO SUPERIOR	x2

ACESSÓRIOS REQUERIDOS

E		03
F		04
J		20
Q		02
V		03

FERRAMENTAS NECESSÁRIAS

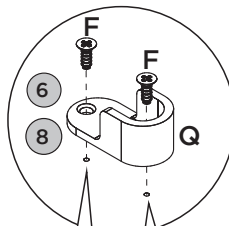
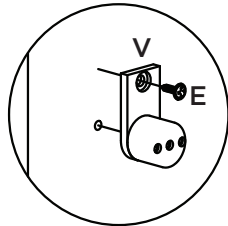
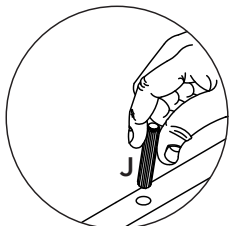
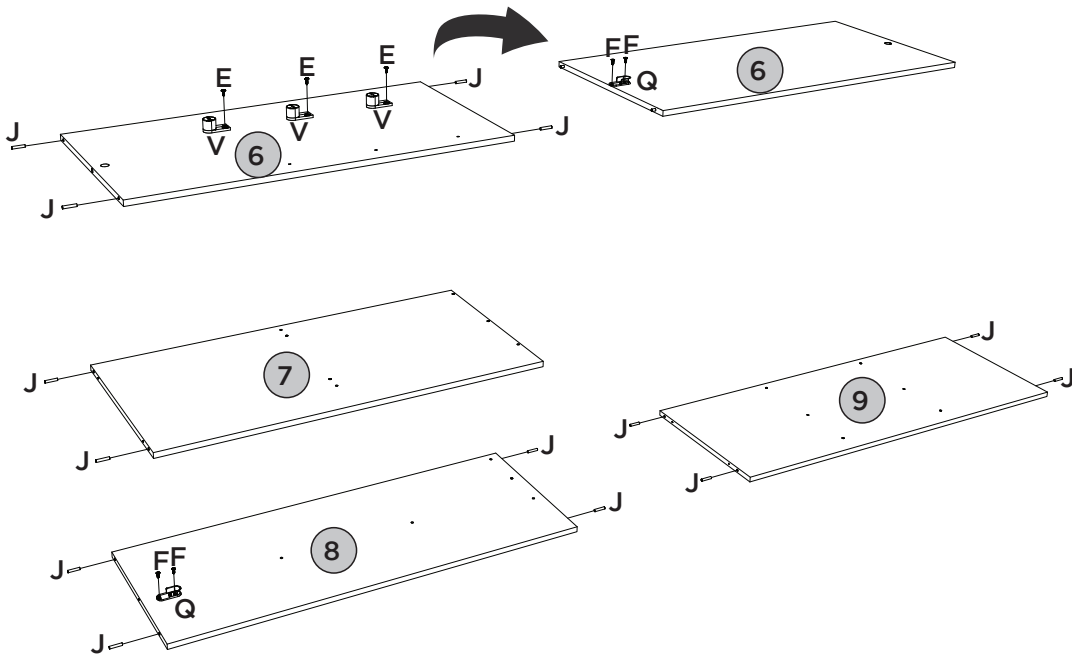
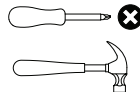

**Observe:
Furos
pré-marcados**





PASSO 4

ITM/D324-

PEÇAS REQUERIDAS

10=15	PRATELEIRA	x8
11	DIVISÃO INFERIOR DIREITA	x1
13	DIVISÃO SUPERIOR DIREITA	x1
17	PRATELEIRA DO CALCEIRO	x1

ACESSÓRIOS REQUERIDOS

E		03
F		04
J		44
Q		02
V		03

FERRAMENTAS NECESSÁRIAS

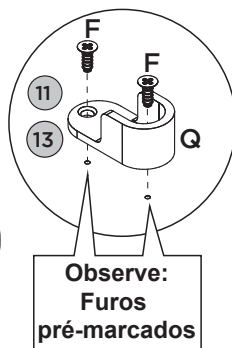
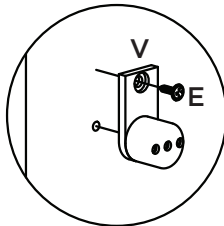
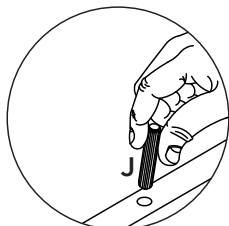
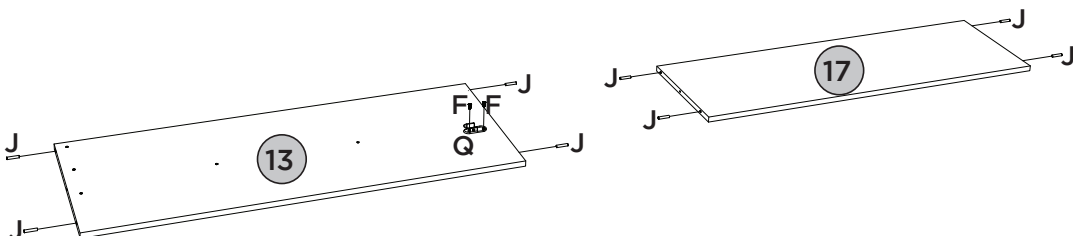
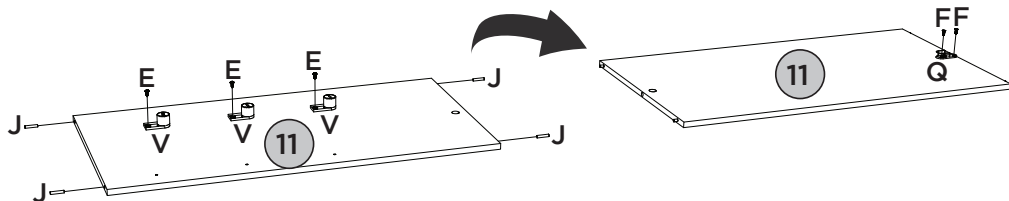
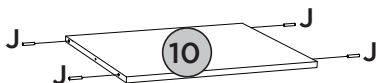
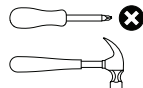

PASSO 5

ITM/D324-

PEÇAS REQUERIDAS

1	RODAPÉ FRONTAL	x1
2	TRAVESSA DO RODAPÉ	x2
3	RODAPÉ TRASEIRO	x1

ACESSÓRIOS REQUERIDOS



FERRAMENTAS NECESSÁRIAS

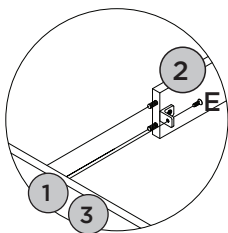
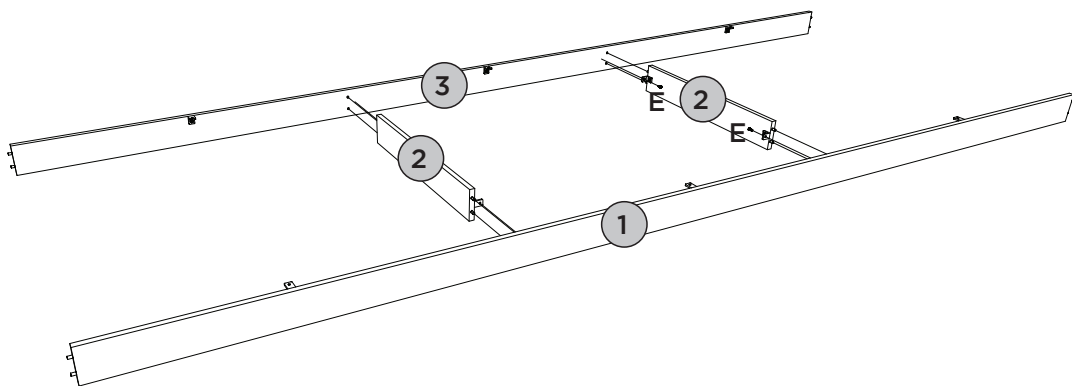
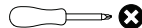





PASSO 6

ITM/D324-

PEÇAS REQUERIDAS

4	BASE	x1
5	LATERAL ESQUERDA	x1
6	DIVISÃO INFERIOR ESQUERDA	x1
11	DIVISÃO INFERIOR DIREITA	x1

ACESSÓRIOS REQUERIDOS

A		02
E		30
I		02
R		08

FERRAMENTAS NECESSÁRIAS

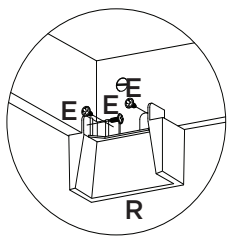
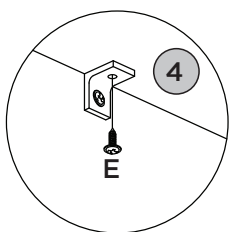
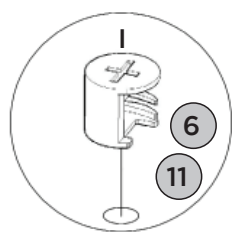
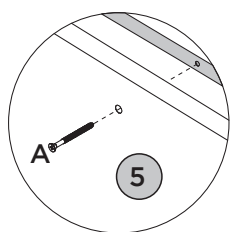
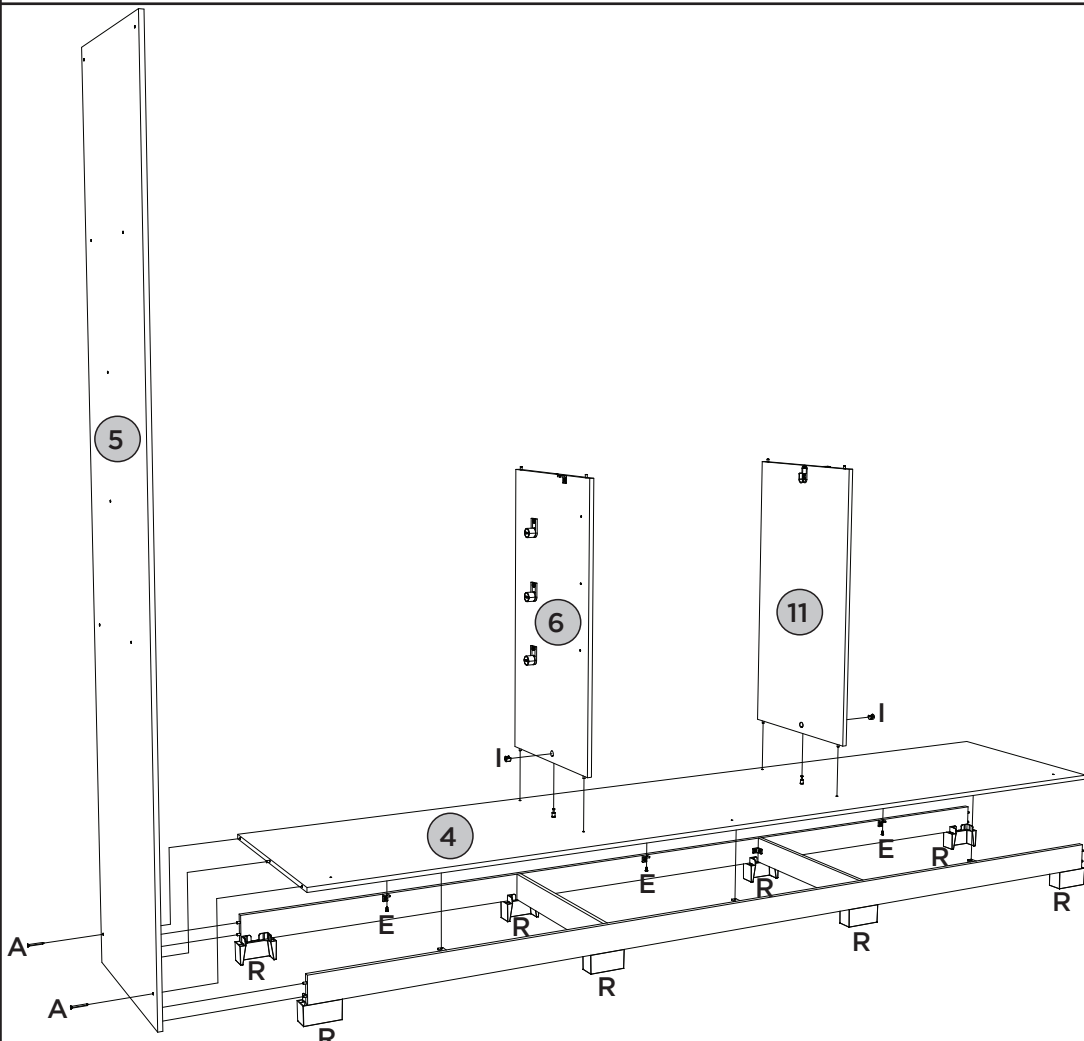
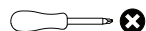

PEÇAS REQUERIDAS

7	TAMPO DAS GAVETAS ESQUERDA	x1
8	DIVISÃO SUPERIOR ESQUERDA	x1
9	DIVISÃO SUPERIOR	x1
10	PRATELEIRA	x2

ACESSÓRIOS REQUERIDOS

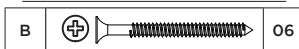



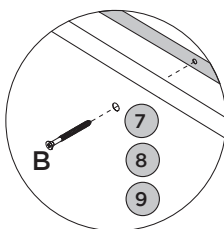
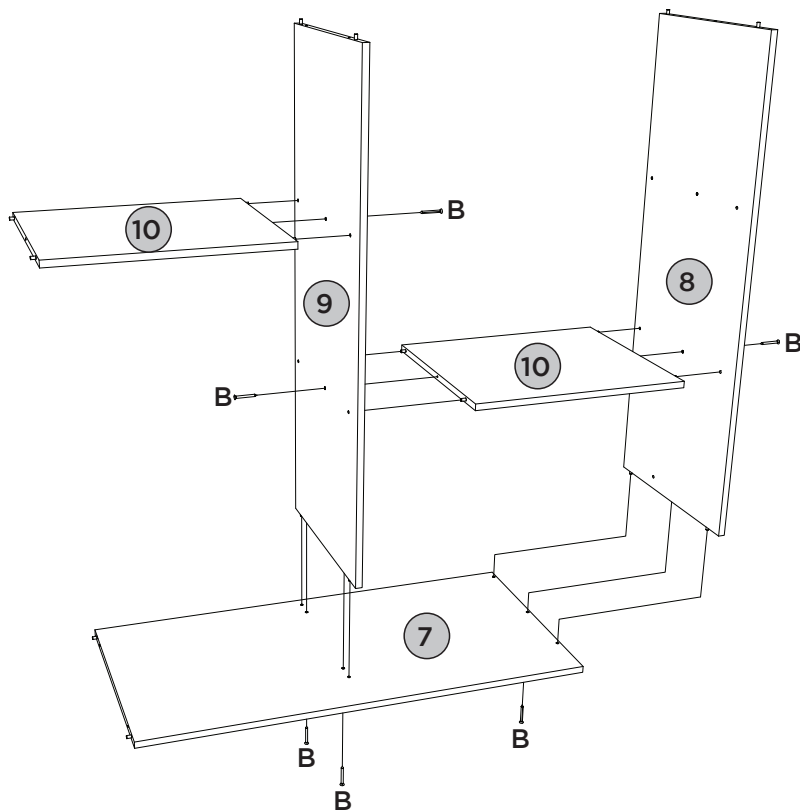
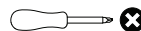



FERRAMENTAS NECESSÁRIAS



PEÇAS REQUERIDAS

10	PRATELEIRA	x2
----	------------	----

ACESSÓRIOS REQUERIDOS

B			05
E			02
N			01

FERRAMENTAS NECESSÁRIAS

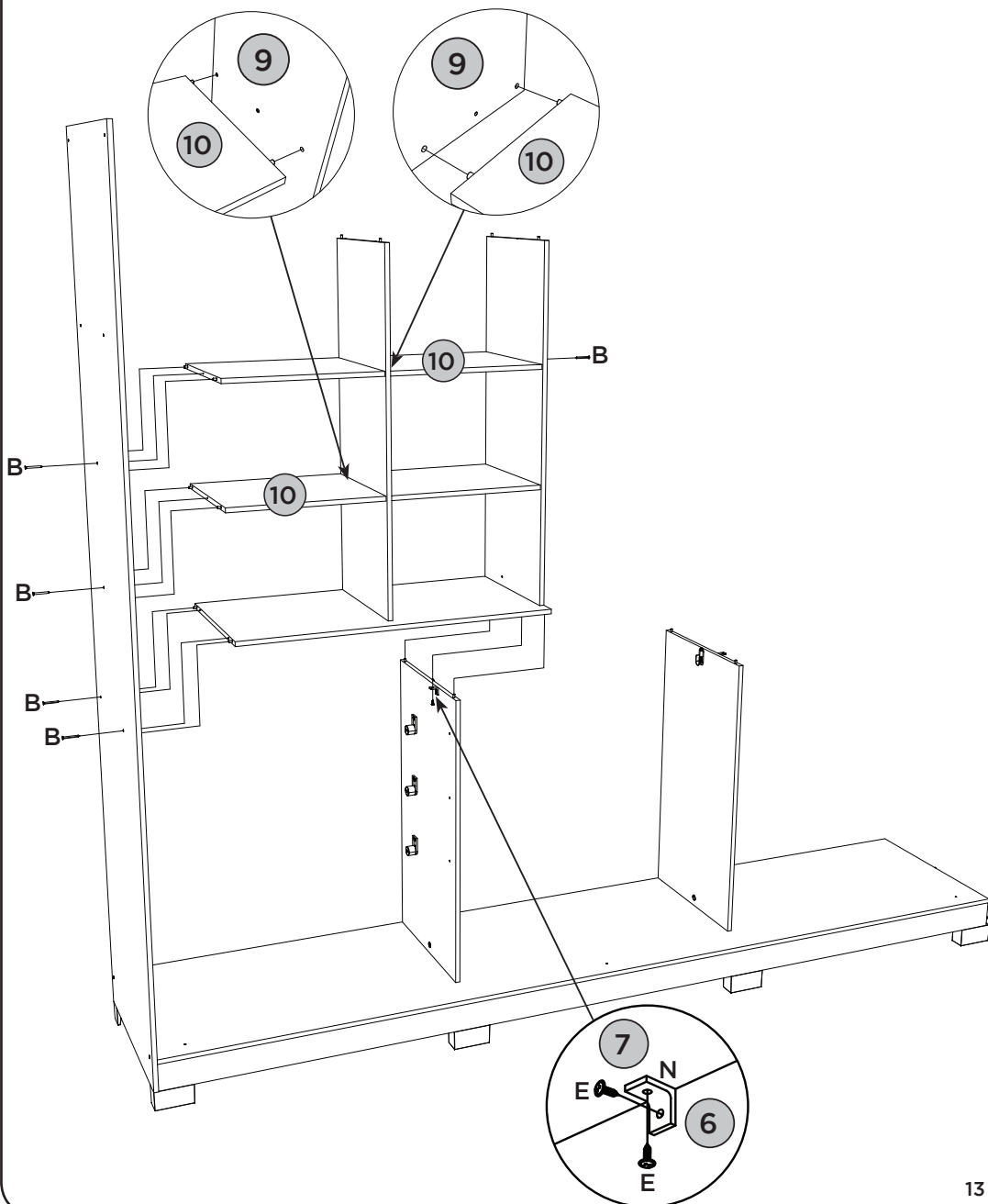
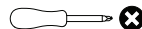

PASSO 9

ITM/D324-

PEÇAS REQUERIDAS

12	TAMPO DAS GAVETAS DIREITA	x1
13	DIVISÃO SUPERIOR DIREITA	x1
14=9	DIVISÃO SUPERIOR	x1
15=10	PRATELEIRA	x2

ACESSÓRIOS REQUERIDOS

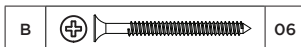

FERRAMENTAS NECESSÁRIAS

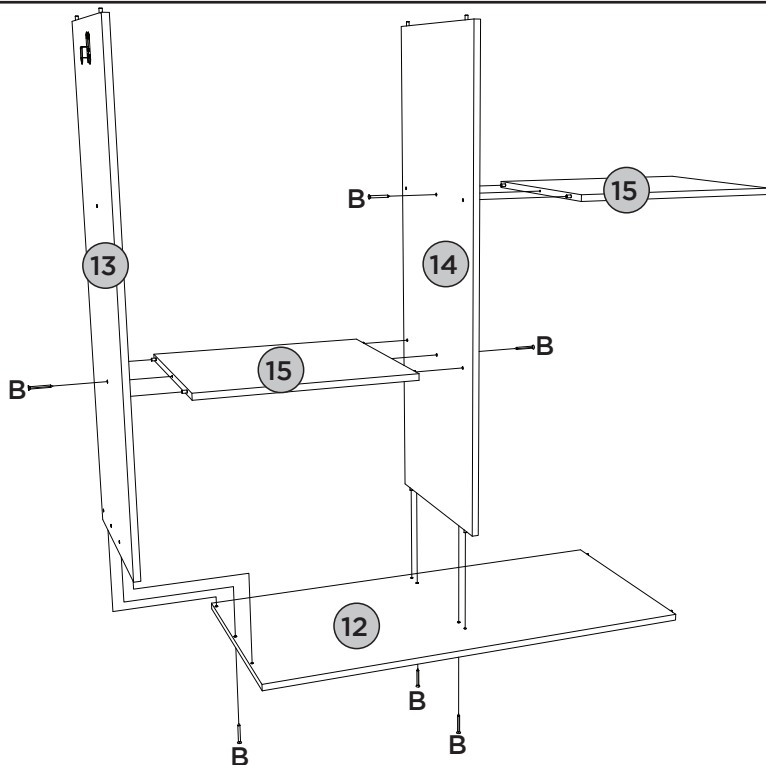
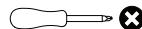

PASSO 10

PEÇAS REQUERIDAS

18	CHÃO DO MALEIRO	x1
19	RIPA DO MALEIRO	x2

ACESSÓRIOS REQUERIDOS

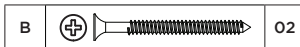

FERRAMENTAS NECESSÁRIAS

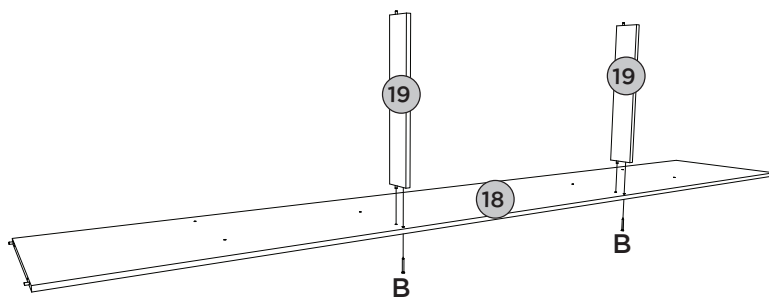
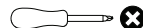





PASSO 11

ITM/D324-

PEÇAS REQUERIDAS

15=10	PRATELEIRA	x2
16	LATERAL DIREITA	x1
17	PRATELEIRA DO CALCEIRO	x1
18	CHÃO DO MALEIRO	x1
19	RIPA DO MALEIRO	x2
20	TAMPO	x1
21	RIPA LATERAL	x4

ACESSÓRIOS REQUERIDOS

A		06
B		19
C		12
E		02
N		01



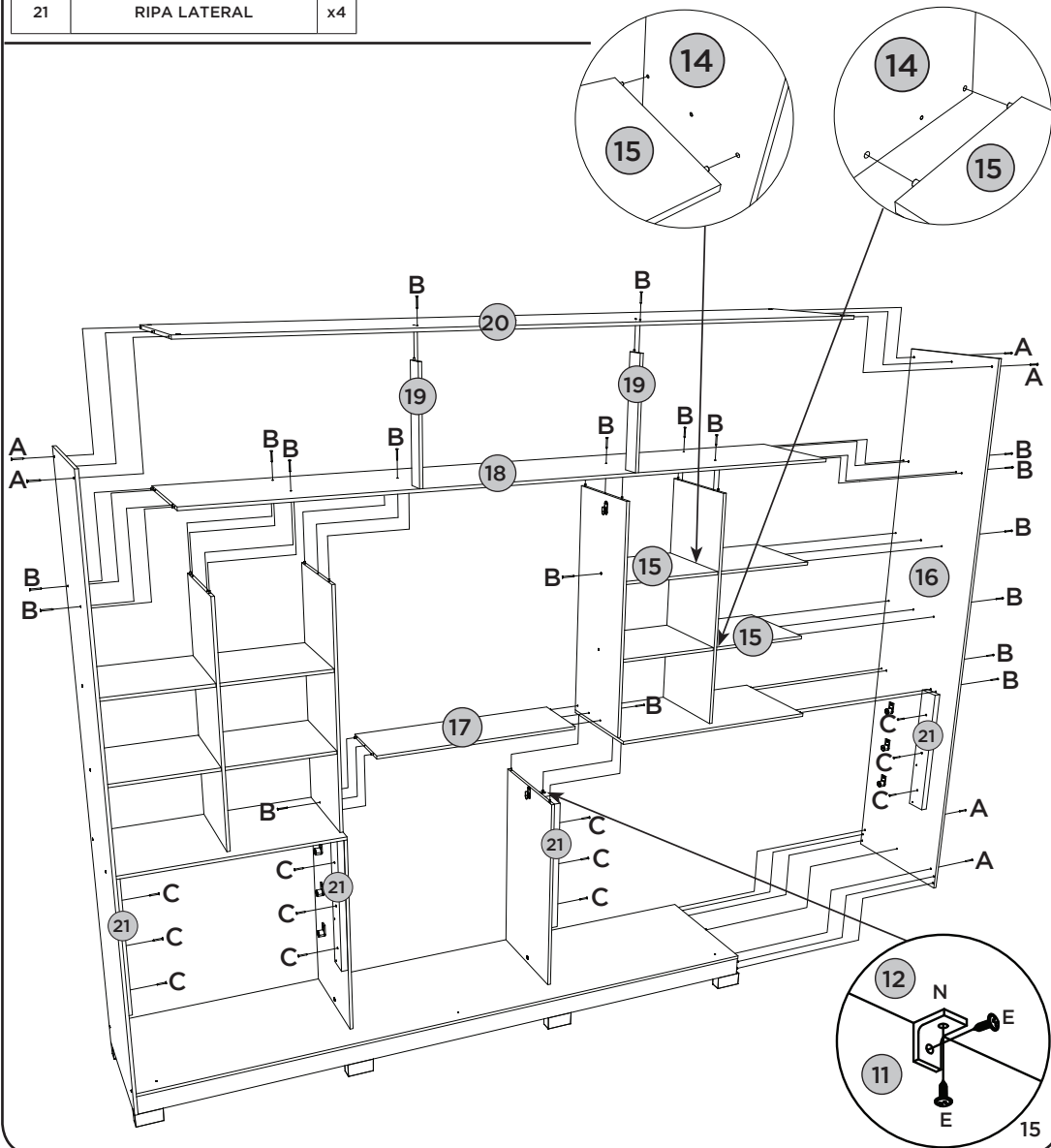
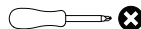

FERRAMENTAS NECESSÁRIAS

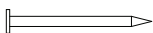

PEÇAS REQUERIDAS

22	FUNDO SUPERIOR	x1
23	FUNDO	x6
24	CHAPÉU	x1

ACESSÓRIOS REQUERIDOS

E		10
K		231
L		56
N		05
W		03

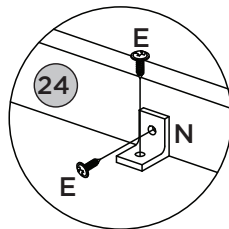
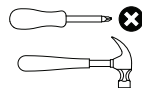
FERRAMENTAS NECESSÁRIAS





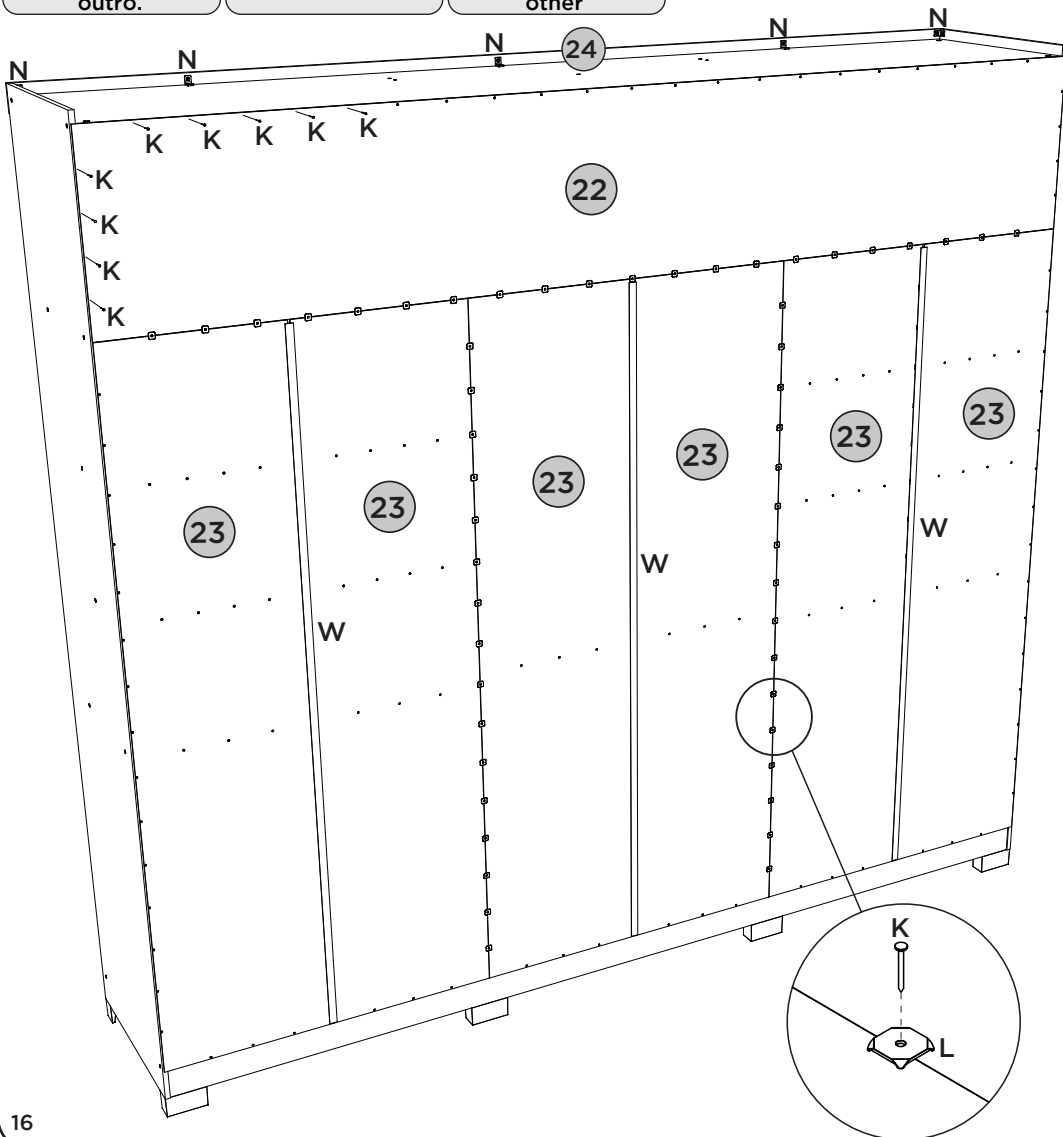

Fixar os pregos a uma distância de 100mm de um para outro.

Fijar las uñas a un distancia de 100mm uno a otro.

Fix the nails at a distance of 100mm from one to the other

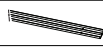

ACESSÓRIOS REQUERIDOS

F		39
S		01
T		02
U		06
Z		01
AA		01

FERRAMENTAS NECESSÁRIAS



Para a fixação do Trilho Superior (Z) é recomendado alinhá-lo com o tampo (20), e deixá-lo centralizado entre as laterais.

Para fijar el Riel Superior (Z) se recomienda alinéelo con la parte superior (20) y déjelo centrado entre los lados.

For fixing the Upper Rail (Z) it is recommended align it with the top (20), and leave it centered between the sides.

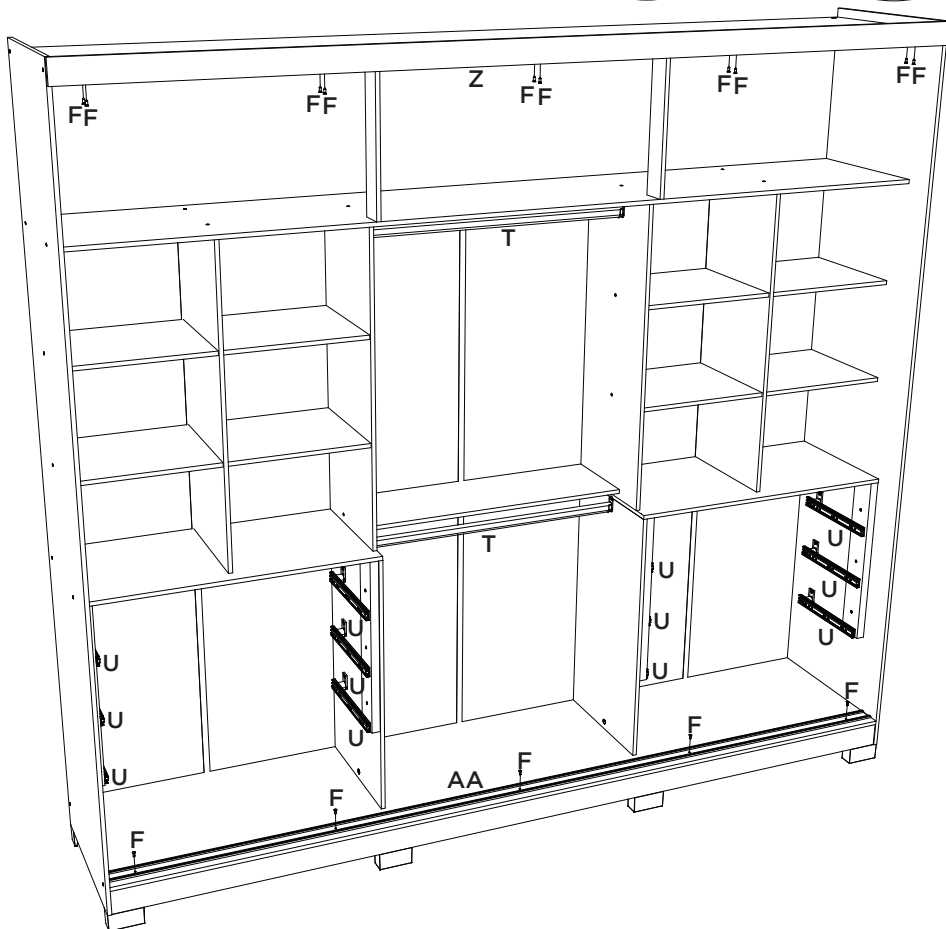
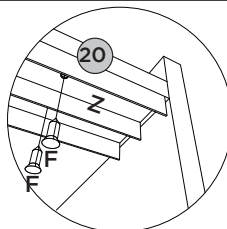
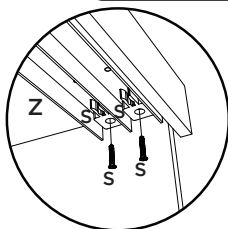
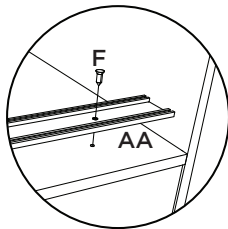
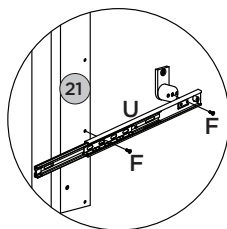

PEÇAS REQUERIDAS

25	PAINEL	x2
26	PAINEL INFERIOR SUPERIOR	x4
28	APLIQUE	x2

ACESSÓRIOS REQUERIDOS

D		24
F		24
G		14
P		12
S		01
Y		04

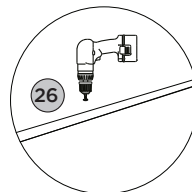
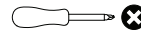
FERRAMENTAS NECESSÁRIAS

Fazer furação passante com Broca de 6mm no Painéis (26) para fixação dos apliques (28)

Taladre agujeros pasantes con un taladro de 6 mm en los paneles (26) para fijar los apliques (28)

Drill in the Panels (26) to fix the appliques (28)

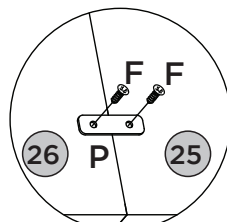
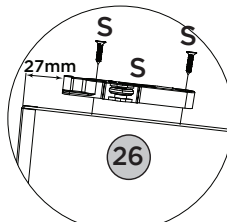
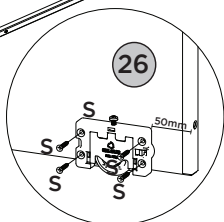
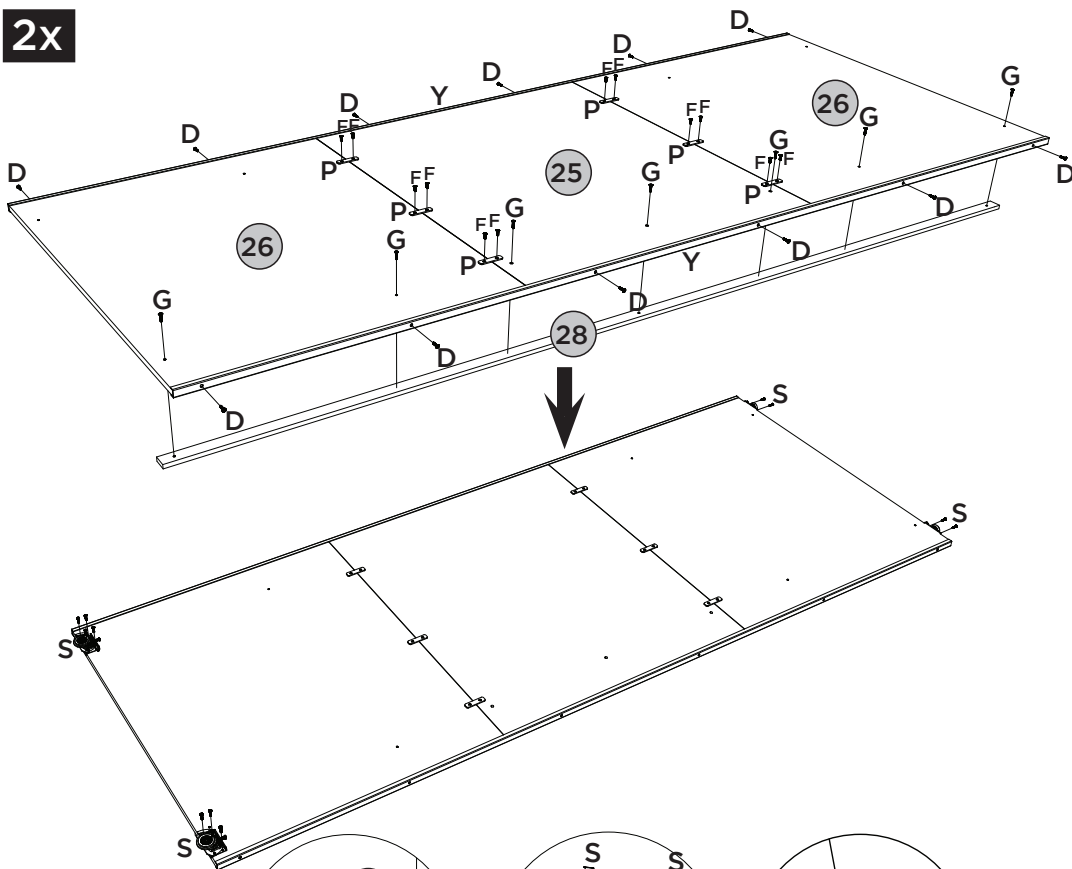
2x

PEÇAS REQUERIDAS

27	PAINEL ESPELHO	x3
28	APLIQUE	x3
29	ESPELHO	x3

ACESSÓRIOS REQUERIDOS

D		12
F		12
G		27
P		06
S		01

FERRAMENTAS NECESSÁRIAS

Y		02
AI		06
AJ		06

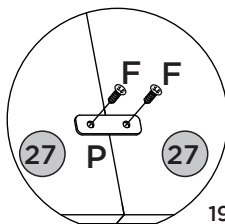
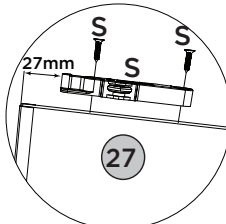
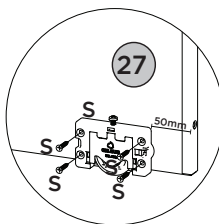
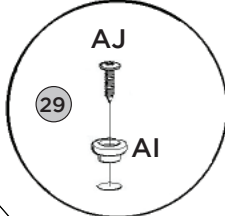
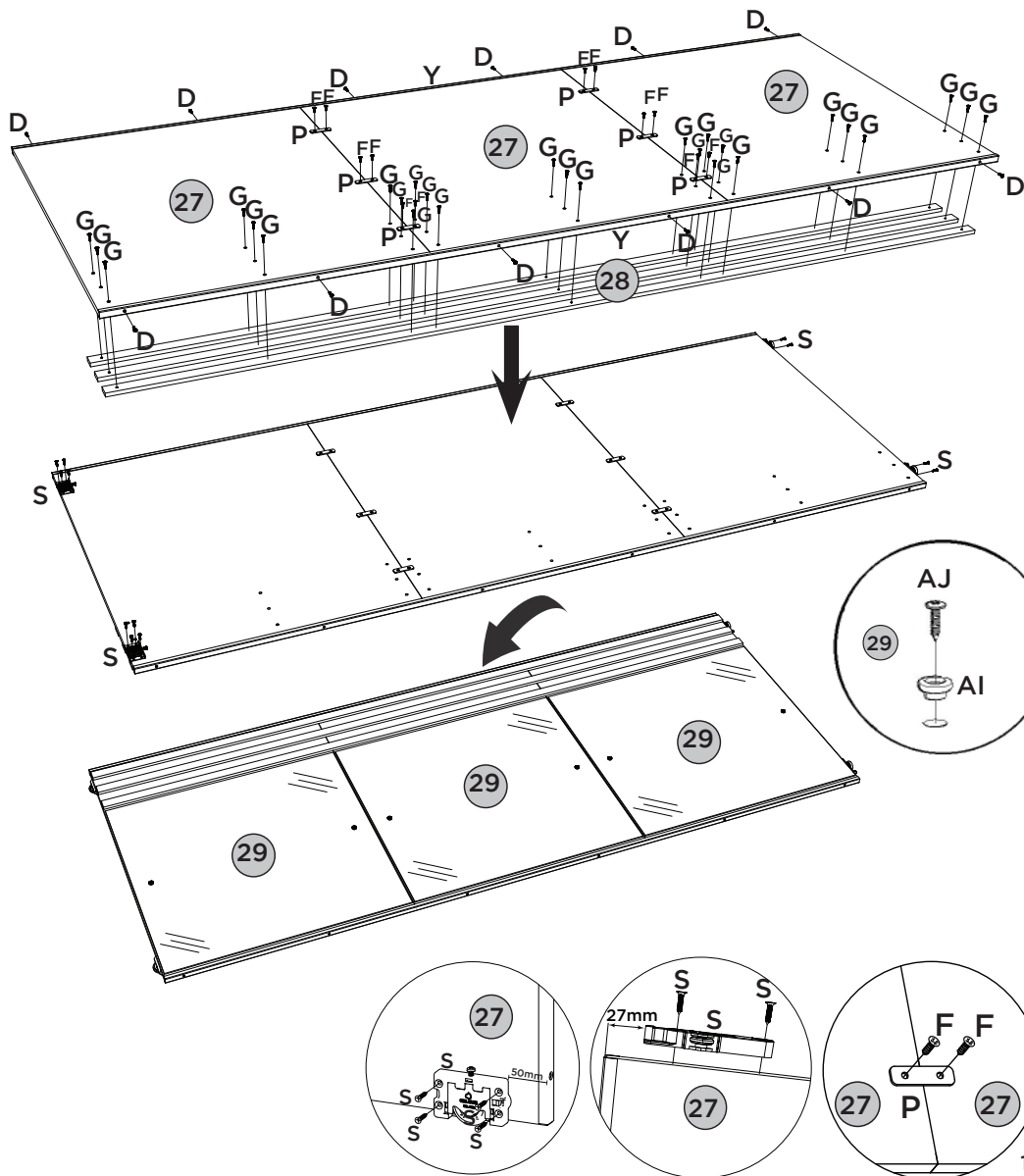



PASSO 16

ITM/D324-

PEÇAS REQUERIDAS

31	LADO DE GAVETA	x12
----	----------------	-----

ACESSÓRIOS REQUERIDOS

J		48
AB		

FERRAMENTAS NECESSÁRIAS

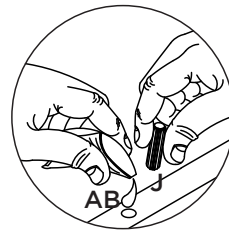
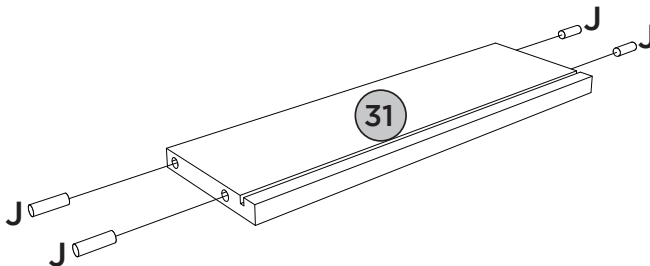
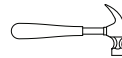



PASSO 17

PEÇAS REQUERIDAS

30	FRENTE DE GAVETA	x6
31	LADO DE GAVETA	x12

ACESSÓRIOS REQUERIDOS

F		24
N		12
AB		

FERRAMENTAS NECESSÁRIAS

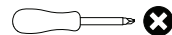

6x

1º

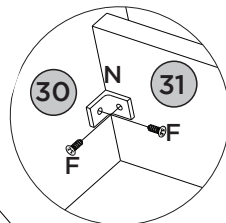
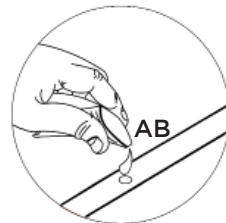
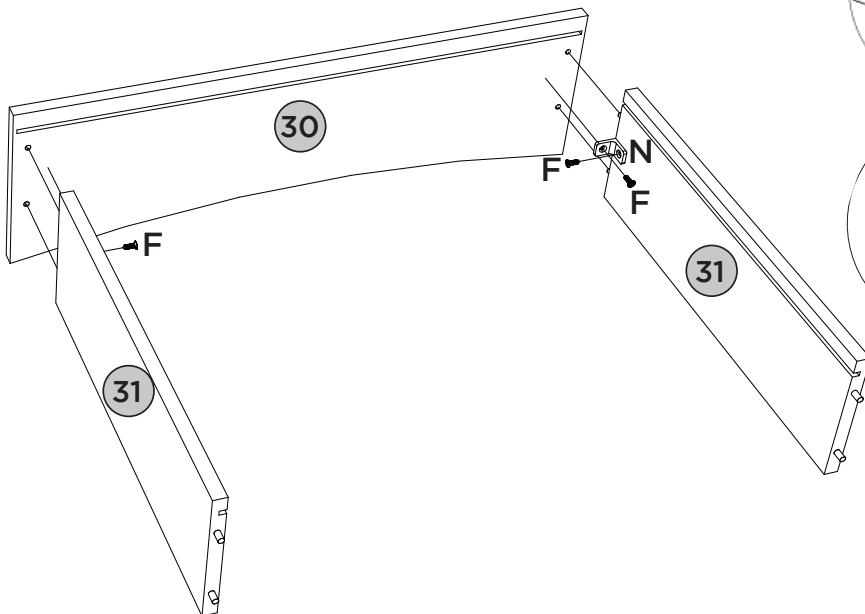

PEÇAS REQUERIDAS

32	FUNDO DE GAVETA RECORTADO	x6
33	RIPA DE TRÁS	x6

ACESSÓRIOS REQUERIDOS

D		12
F		36
O		12
U		06

FERRAMENTAS NECESSÁRIAS

X		12
AB		

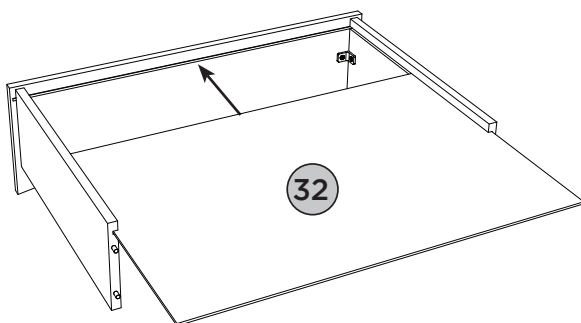
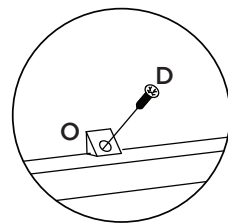
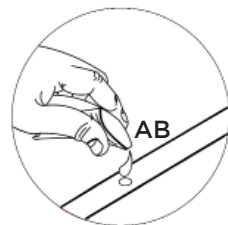
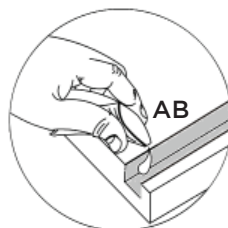
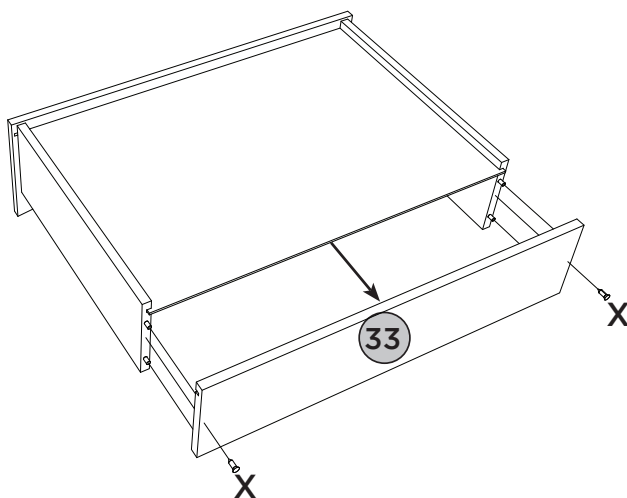
6x
2º

6x
3º

6x
4º

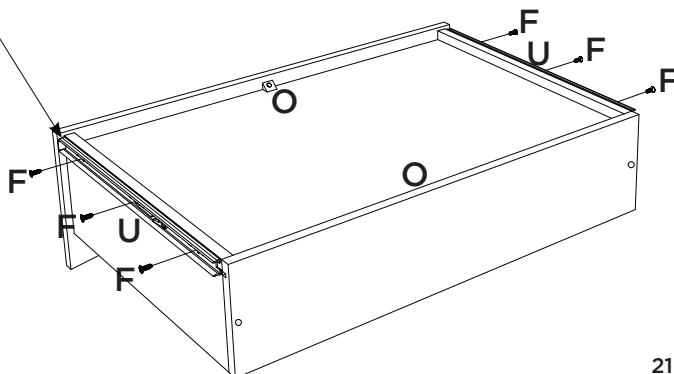

Deixar 3mm de distância da frente de gaveta.

Deje una separación de 3mm del frente del cajón.

Leave 3mm away from the front of the drawer.



ACESSÓRIOS REQUERIDOS

AC		04
AD		34
AF		03
AH	HENN	01

Pesos máximos recomendados com carga distribuída
 Peso máximo recomendado con la carga distribuida
 Recommended maximum weight with distributed load.

2490mm

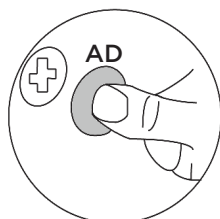
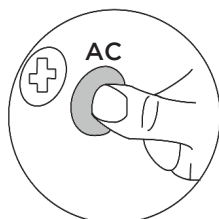
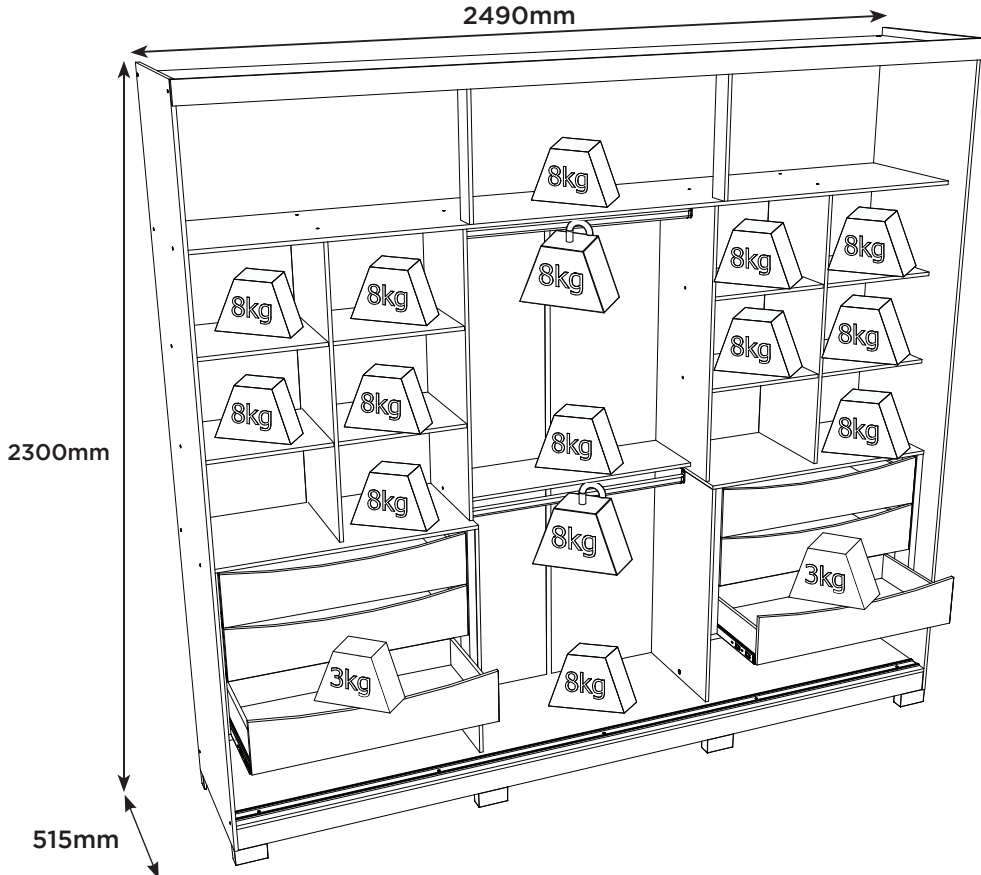

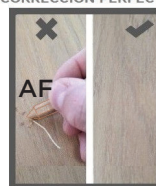

PERFECT CORRECTION
 CORRECCIÓN PERFECTA



PEÇAS REQUERIDAS

25	PAINEL	x2
26	PAINEL INFERIOR SUPERIOR	x4
27	PAINEL ESPELHO	x3
28	APLIQUE	x5
29	ESPELHO	x3

ACESSÓRIOS REQUERIDOS

AE		36
AG		24



Para a colocação das portas nos trilhos encaixe primeira a porta no trilho de PVC superior (Z) e em seguida no trilho de alumínio inferior (AA).

Para la colocación de las puertas en la pista instalación de la puerta en la primera banda superior PVC (Z) y luego el riel de aluminio inferior (AA).

For placing the doors on the rails fitting the door on the PVC rail first (Z) and then on the lower aluminum rail (AA).

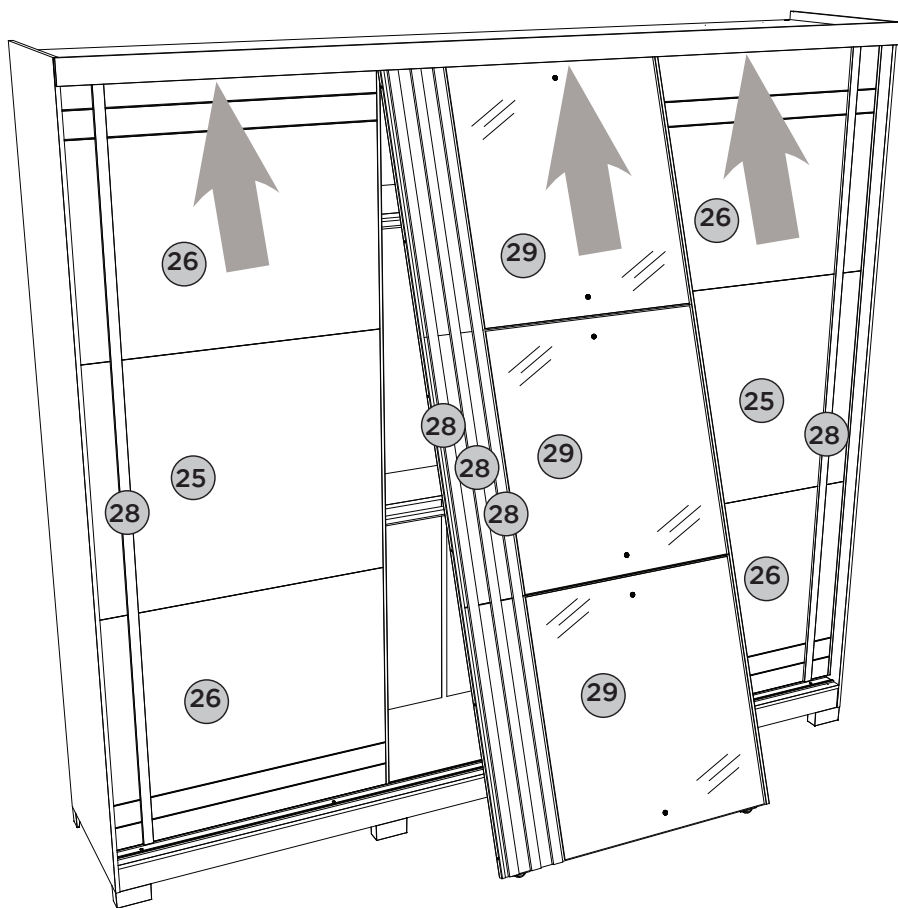
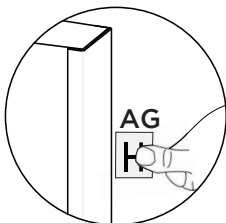
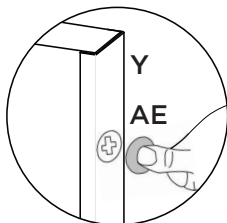

Produto Concluído
Producto terminado
Finished Product

