



PRODUTO: ROUPEIRO 7P 1 GAVETAS	CÓDIGO :A646
---------------------------------------	--------------

NOME DA PEÇA / NAME OF PARTS			
A	PARAFUSO / SCREW 3.5X12MM	130	
B	PARAFUSO / SCREW 3.5X25MM	16	
C	PARAFUSO / SCREW 3.5X30MM	16	
D	PARAFUSO / SCREW 4.0X50MM	36	
E	PARAFUSO / SCREW M4X25MM	8	
F	PORCA / NUT M4	8	
G	PREGO / NAIL 08X08MM	120	
H	DOBRADIÇA / METAL HIGE	18	
I	CALÇO / PLATE HIGE 5MM	18	
J	CANTONEIRA / METAL CONNECTION	8	
K	SUPORTE CABIDEIRO / SUPPORT	6	
L	CAVILHA / PLUG 6X30MM	4	
M	COLA / GLUE	1	
N	LOGAMARCA / TAG	1	
O	PUXADOR VENEZA 128MM / HANDLE	8	
P	CORREDIÇA / METAL RAILS	1	
Q	PÉ DE ROUPEIRO / FOOT 70MM	6	
R	CABIDEIRO DE MADEIRA / SUPPORT 330MM	3	
S	PERFIL H 1650MM / PROFILE	2	

ASPECTO FINAL



NOME DA PEÇA / NAME OF PARTS			
P0			
P44476	RODAPÉ FRONTAL / FRONT VIEW	1326 X 124 X 15MM	1
P44477	RODAPÉ TRASEIRO / BACK VIEW	1326 X 124 X 15MM	1
P44478	TRAVA RODAPÉ / SUPPORT VIEW	328 X 65 X 15MM	5
P44479	BASE INTERMEDIARIA / INTERMEDIARY BASE	1326 X 360 X 15MM	1
P44480	CHAPÉU / TOP	1326 X 360 X 15MM	1
P44481	VISTA SUPERIOR / SUPERIOR VIEW	1326 X 50 X 15MM	1
P44482	LATERAL DIREITA / RIGHT SIDE	1750 X 360 X 15MM	1
P44483	DIVISÃO DIREITA / RIGHT DIVISION	576 X 360 X 15MM	1
P44484	LATERAL DE GAVETA / DRAWER SIDE	350 X 100 X 15MM	2
P44485	CONTRA FUNDO / DRAWER BACK	376 X 100 X 15MM	1
P44486	BATENTE FRONTAL / COLUMN	970 X 94 X 15MM	2
P44487	DIVISÃO ESQUERDA / LEFT DIVISION	576 X 360 X 15MM	1
P44488	LATERAL ESQUERDA / LEFT SIDE	1750 X 360 X 15MM	1
P44489	PORTA DIR & ESQ / RIGHT AND LEFT DOOR	1576 X 220 X 15MM	4
P44490	PORTA CENTRAL / CENTRAL DOOR	1000 X 220 X 15MM	2
P44491	FRENTE DE GAVETA / DRAWER FRONT	442 X 220 X 15MM	1
P44492	PORTA INFERIOR / INFERIOR DOOR	442 X 348 X 15MM	1
P44493	FUNDO BASE / BACK BASE	430 X 358 X 03MM	3
P44494	FUNDO DE GAVETA / DRAWER BACK	403 X 355 X 03MM	1
P44495	FUNDO / BACK	1620 X 442 X 03MM	3

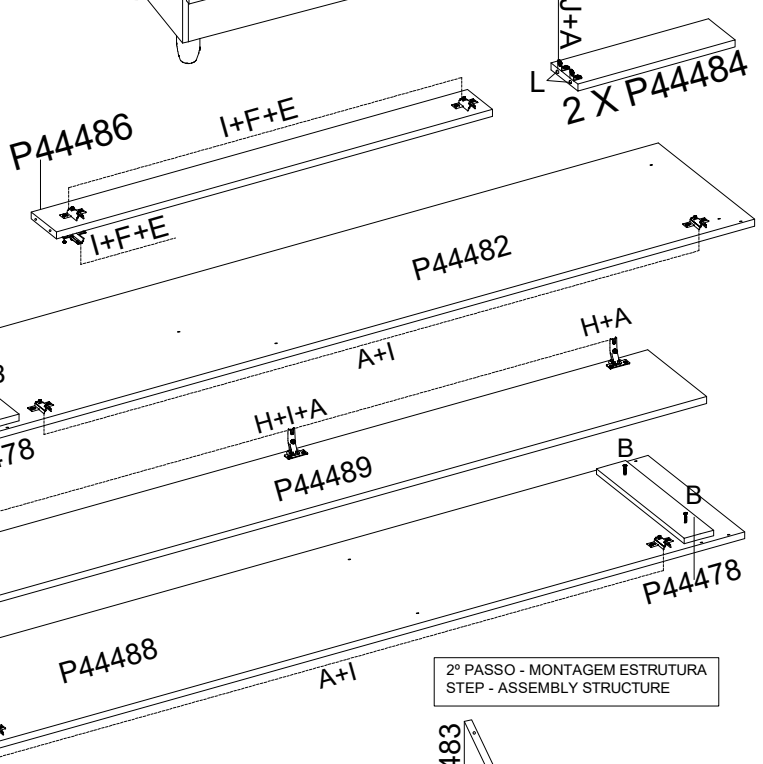

1º PASSO - PREPARAÇÃO DA PEÇAS

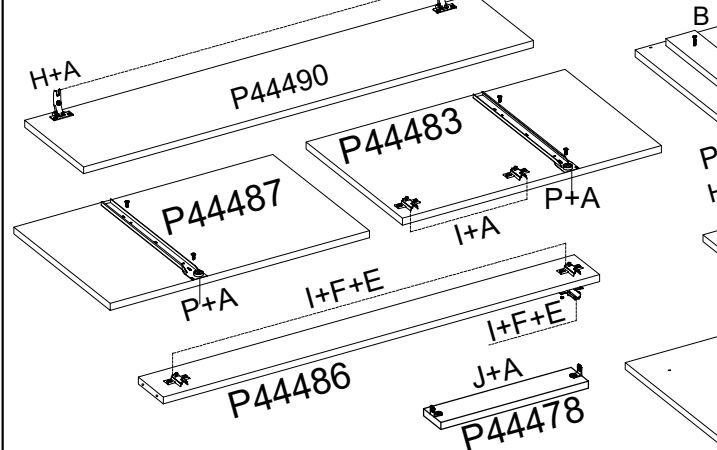

MONTAGEM DA GAVETA
DRAWER ASSEMBLY

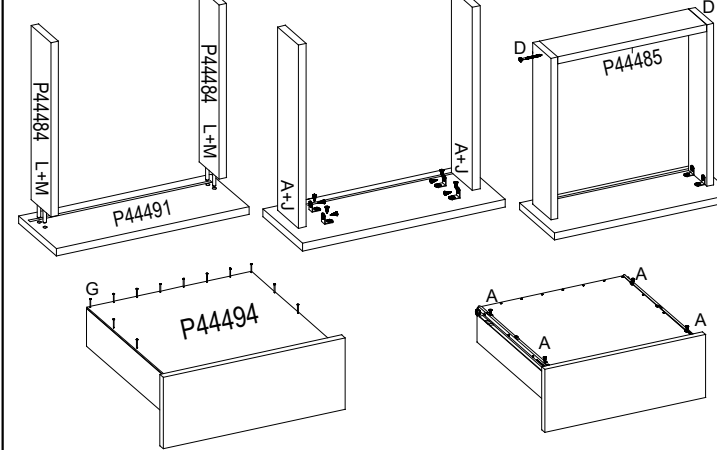

2º PASSO - MONTAGEM ESTRUTURA
STEP - ASSEMBLY STRUCTURE

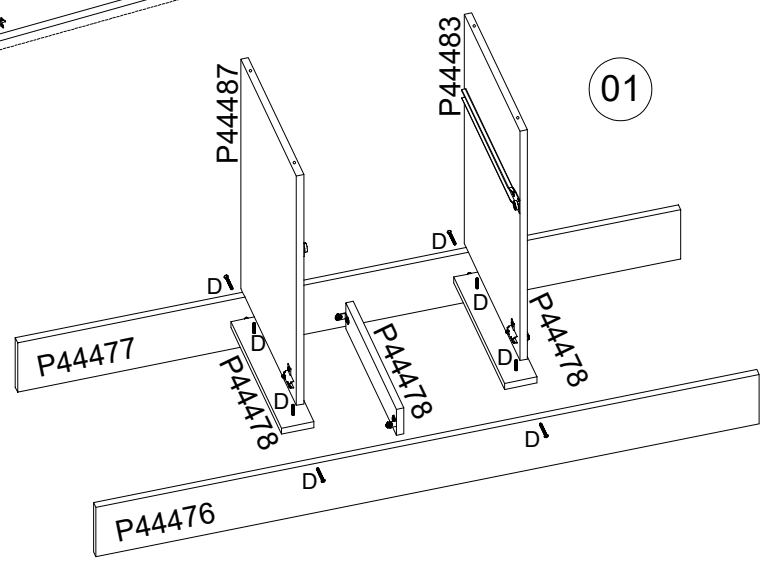

01

3º PASSO - MONTAGEM ESTRUTURA
STEP - ASSEMBLY STRUCTURE

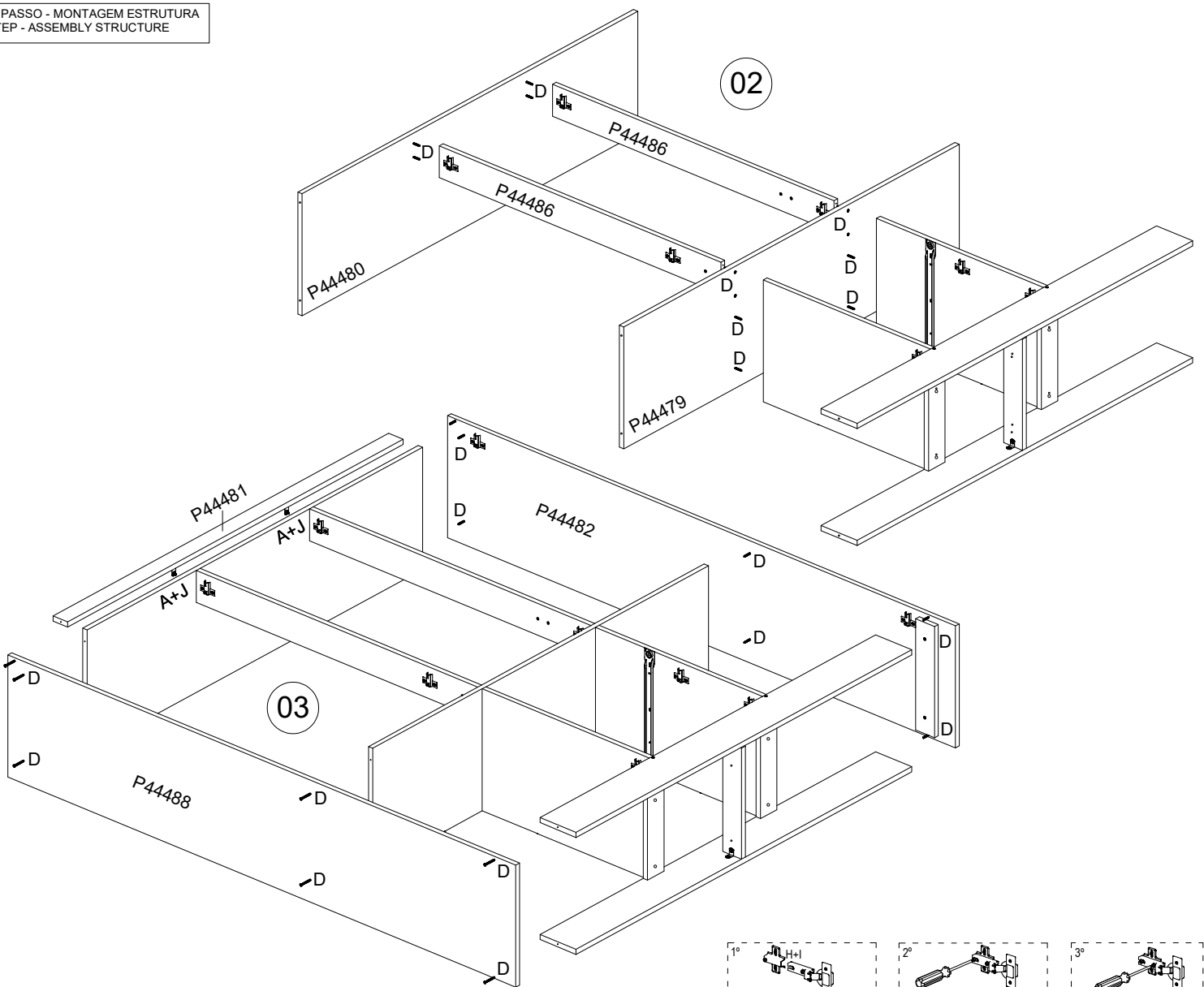

1º FIXAR A DOBRADICA NA PORTA COMO MOSTRA O DESENHO AO LADO.
2º FAZER A JUNCÃO DA DOBRADICA COM O CALÇO E APERTAR O PARAFUSO CENTRAL.
3º APÓS A JUNCÃO FECHAR A PORTA E FAZER A REGULAGEM PRECISA.

4º PASSO - PREGAR OS FUNDOS
STEP - BACK ASSEMBLY

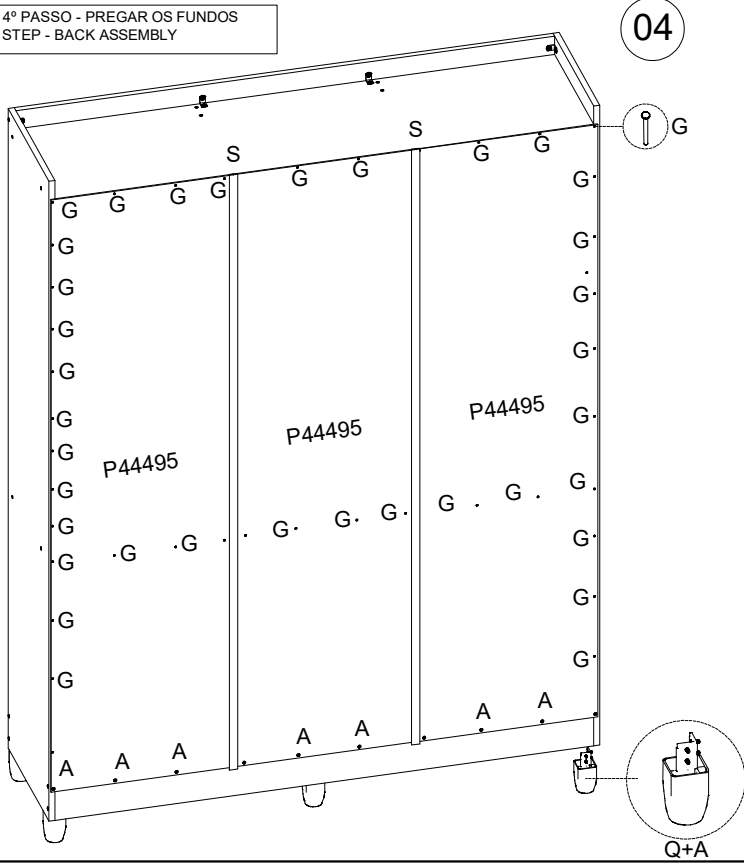

5º PASSO - COLOCAÇÃO DAS PORTAS
STEP - DOOR ASSEMBLY

