

# MANUAL COMPLETO COMPLETE MANUAL

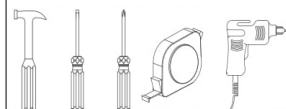

DEMÓBILE Indústria de Móveis Ltda.  
Rua : Jurutau, 1350 - Pq. Industrial II.  
Cep.: 86703-070  
Arapongas - PR - Brasil  
demobile@demobile.com.br



## Avisos

1. Ler atentamente as instruções do manual antes de iniciar a montagem do móvel.
2. A montagem deverá ser feita em superfície limpa e plana, aconselhamos forrar o chão com a embalagem do produto, para não danificar.
3. Os parafusos devem ser apertados periodicamente.
4. Evitar batidas e contato com objetos cortantes.
5. O peso máximo de carga informado refere-se a objetos distribuídos de maneira uniforme sobre toda área de contato da peça.

### Limpeza e Conservação

Efetuar a limpeza somente com pano macio limpo e seco.  
Não Utilizar produtos abrasivos ou químicos.

### Garantia

1. O fabricante responsabiliza-se apenas pelas peças do produto.
2. A montagem incorreta acarretará na perda da garantia e das assistências, desta forma o produto deverá ser montado por profissional qualificado.
3. Não estão cobertos pela garantia problemas que tenham origem na utilização inadequada do produto ou na exposição do mesmo a intempéries como: infiltrações, infestação de pragas em geral, aparecimento de mofo e outros, decorrentes do ambiente de instalação.

Assistência Técnica: Em caso de peças em assistência técnica é necessário que as mesmas sejam solicitadas junto a loja ou site no qual a compra do produto foi realizada

## Warnings

1. Read the manual instructions carefully before starting to assemble the furniture.
2. The assembly must be done in clean and flat surface, we advise to put the product packaging on the floor, not to damage it during the assembling.
3. The screws must be tightened periodically.
4. Avoid hitting and contacting sharp objects.
5. The payload informed refers to the objects distributed all over the piece contact area.

### Cleaning and conservation

Clean the product just with a soft, cleaned and dry cloth.  
Do not use abrasive or chemicals products.

### Warranty

1. The manufacturer is only responsible for product parts.
2. Incorrect assembling will make you lost the guarantee and assistance, in this way the product must be assembled by qualified professional.
3. It is Not covered by the warranty problems caused by an inappropriate use of the product or product exposure even in bad weather, such as: infiltrations, pest infestation in general, appearance of mold and others, caused by the installation environment.

Technical Assistance: Damaged pieces! Ask on the stores you bought it.

## Advertencias

1. Lee atentamente las instrucciones del manual antes de empezar a armar los muebles.
2. El montaje debe hacerse en superficie limpia y plana, utilice el empaque del Producto para cubrir el piso
3. Los tornillos deben ser apretados periódicamente
4. Evite golpear y chocar objetos punzantes
5. El peso máximo de carga tiene relación a los objetos distribuydos sobre toda el área de contacto de la pieza.

### Limpeza y conservación

Limpiar solo con un trapo suave, limpio y seco  
No utilice productos abrasivos o productos químicos

### Garantía

1. El fabricante solo es responsable a las partes del producto.
2. Armar incorrectamente supone la pérdida de garantía y repuestos, de esta manera el producto debe ser ensamblado por profesional calificado
3. No es garantizado problemas derivados del uso inapropiado del producto, o exposición del producto al mal tiempo, como: infiltraciones, infestación de plagas en general, aparición de moho y otros.

Asistencia técnica: en caso de piezas rotas es necesario que sea solicitadas las mismas a la tienda o sitio web donde se compró el producto.

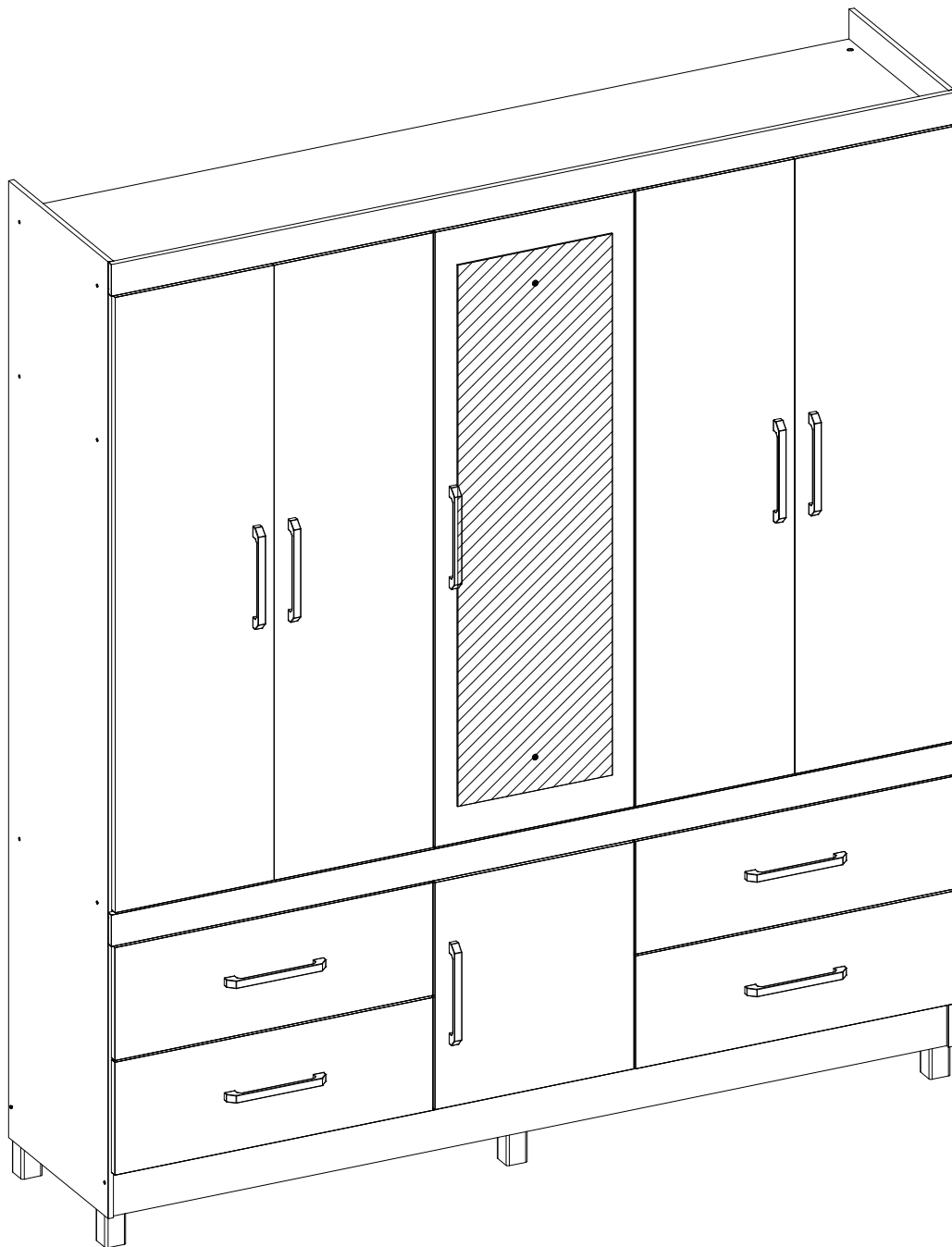

**64720 GUARDA ROUPA CASAL 6 PORTAS 4 GAVETAS GUARUJA**

**64720 WARDROBE 6 DOORS 4 DRAWERS GUARUJA**

**64720 CLOSET MATRIMONIAL 6 PUERTAS 4 CAJONES GUARUJA**

64720

GUARDA ROUPA CASAL 6 PORTAS 4 GAVETAS GUARUJA  
 WARDROBE 6 DOORS 4 DRAWERS GUARUJA  
 CLOSET MATRIMONIAL 6 PUERTAS 4 CAJONES GUARUJA

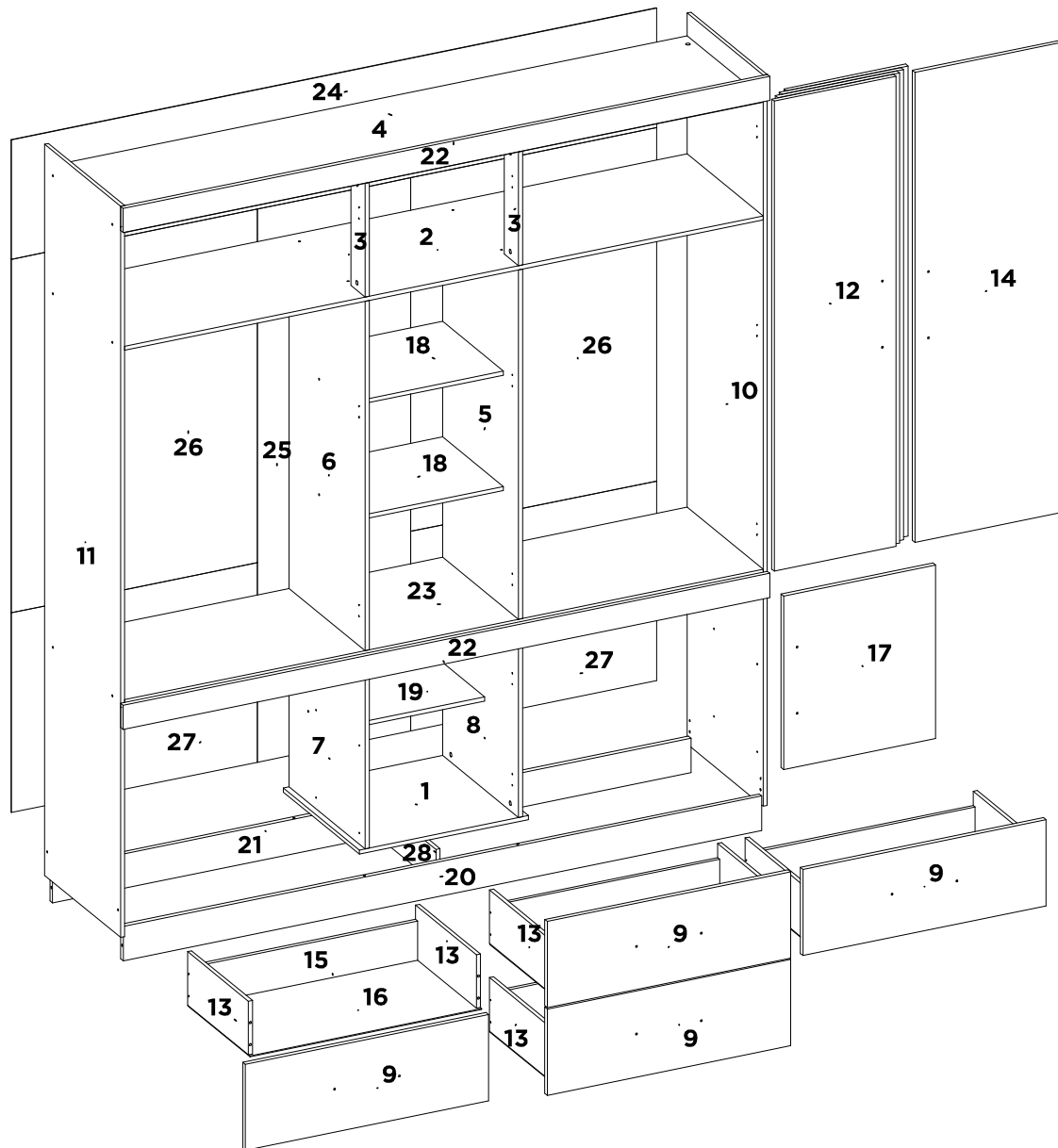

SEQ.	CODIGO	AMENDOLA OFF WHITE	EBANO TOUCH	NOGAL VANILLA TOUCH	EBANO OFF WHITE	AMENDOLA TOUCH	REF_06	REF_07	DESCRIÇÃO DE PECAS DESCRIPTION OF PARTS DESCRIPCION DE LAS PIEZAS	DESCRIPTION_EN	DESCRIPCION_ES	DIMENSÕES / QUANTIDADE DIMENSIONS / QUANTITY DIMENSIONES / CANTIDAD	QTD
1	03070	138	112	113	112	138	-	-	BASE	BASE	BASE	500 X 450 X 12	1
2	04040	138	112	113	112	138	-	-	BASE MALEIRO	LUGGAGE BASE	BASE DEL MALETERO	1890 X 450 X 12	1
3	05069	138	112	113	112	138	-	-	BATENTE DO MALEIRO	FRONT SUPPORT	SOPORTE FRONTAL	330 X 85 X 12	2
4	07059	138	112	113	112	138	-	-	CHAPEU	TOP PANEL	TAPA SUPERIOR DEL ROPERO	1890 X 450 X 12	1
5	08149	138	112	113	112	138	-	-	DIVISAO DIREITA	RIGHT DIVISION	DIVISION DERECHA	1013 X 450 X 12	1
6	08150	138	112	113	112	138	-	-	DIVISAO ESQUERDA	LEFT DIVISION	RIGHT DIVIDE	1013 X 450 X 12	1
7	08151	138	112	113	112	138	-	-	DIVISAO GAVETA ESQ	LEFT DIVISION	RIGHT DIVIDE	563 X 450 X 12	1
8	08152	138	112	113	112	138	-	-	DIVISAO GAVETA DIR	RIGHT DIVISION	DIVISION DERECHA	563 X 450 X 12	1
9	09087	140	105	108	132	134	-	-	FRENTE DE GAVETA	DRAWER FRONT	FRENTE DEL CAJON	720 X 250 X 15	4
10	11188	136	110	111	110	136	-	-	LATERAL DIREITA	RIGHT SIDE PANEL	LATERAL DERECHA	2120 X 450 X 12	1
11	11189	136	110	111	110	136	-	-	LATERAL ESQUERDA	LEFT SIDE PANEL	LATERAL IZQUIERDA	2120 X 450 X 12	1
12	14154	140	105	108	132	134	-	-	PORTA LATERAL	DOOR	PUERTA	1363 X 360 X 15	4
13	12009	138	112	113	112	138	-	-	LATERAL DE GAVETA	DRAWER SIDE	LATERAL DEL CAJON	360 X 155 X 12	8
14	14155	140	105	108	132	134	-	-	PORTA CENTRAL	DOOR	PUERTA	1363 X 450 X 15	1
15	06066	138	112	113	112	138	-	-	CONTRA FUNDO	DRAWER BACK	CONTRA FONDO	663 X 114 X 12	4
16	10058	138	112	113	112	138	-	-	FUNDO GAVETA	DRAWER BASE	FONDO DEL CAJON	685 X 368 X 3	4
17	14156	140	105	108	132	134	-	-	PORTA SAPATEIRA	DOOR	PUERTA	503 X 450 X 15	1
18	15082	138	112	113	112	138	-	-	PRATELEIRA CENTRAL	SHELF	ESTANTERIA	442 X 360 X 12	2
19	15083	138	112	113	112	138	-	-	PRATELEIRA DA SAPATEIRA	SHELF	ESTANTERIA	442 X 250 X 12	1
20	16182	134	105	106	105	134	-	-	RODAPE FRONTAL	BOTTOM BOARD FRONT	ZÓCALO FRONTAL	1890 X 100 X 15	1
21	16183	20	20	20	20	20	-	-	RODAPE TRASEIRO	BOTTOM BOARD BACK	ZÓCALO TRASERO	1890 X 100 X 15	1
22	17050	134	105	106	105	134	-	-	RODATETO VISTA GAVETA	TOP FRONT BOARD	MOLDURA SUPERIOR	1914 X 70 X 15	2
23	19124	138	112	113	112	138	-	-	TAMPO GAVETEIRO	DRAWER CABINET TOP PANEL	TAPA DEL CAJÓN	1890 X 450 X 12	1
24	20182	138	112	113	112	138	-	-	TRASEIRO DO MALEIRO	BACK PANEL	TRASERO	1910 X 346 X 3	1
25	20183	138	112	113	112	138	-	-	TRASEIRO CENTRAL	BACK PANEL	TRASERO	1604 X 454 X 3	1
26	20184	138	112	113	112	138	-	-	TRASEIRO LATERAL	BACK PANEL	TRASERO	1025 X 728 X 3	2
27	20185	20	20	20	20	20	-	-	TRASEIRO GAVETEIRO	BACK PANEL	TRASERO	728 X 579 X 3	2
28	24009	20	20	20	20	20	-	-	APOIO DO PE	BOTTOM BOARD INTERNAL	ZÓCALO INTERNO	404 X 100 X 12	1

# LISTA DE AÇESSÓRIOS / LIST OF ACCESSORIES / LISTA DE ACCESORIOS

SEQ.	CODIGO.	DESCRIÇÃO	DESCRIPTION_EN	DESCRIPCION_ES	QTD.
-	01137	KIT DE ACESSORIOS	KIT OF ACCESSORIES	KIT DE ACCESORIOS	1
A	9905002	PARAFUSO 3.5 X 12 MM CHATA PHILIPS	PHILIPS FLAT HEAD SCREW	TORNILLO CHATA PHILIPS	70
AH	9904035	PUXADOR ECON F 192 MM BRONZE	HANDLE	TIRADOR	10
B	9905003	PARAFUSO 3.5 X 12 MM FLANGEADO PHILIPS	PHILIPS FLANGE SCREW	TORNILLO DE BRIDA PHILIPS	40
C	9905046	PARAFUSO 3.5 X 14 MM CHATA PHILIPS	PHILIPS FLAT HEAD SCREW	TORNILLO CHATA PHILIPS	32
DB	9901045	CABIDEIRO OBLONGO 704 X 20 X 15 MM ALUMINIO	HANGER	PERCHERO	2
E	9905020	PARAFUSO 3.5 X 30 MM CHATA PHILIPS	PHILIPS FLAT HEAD SCREW	TORNILLO CHATA PHILIPS	36
F	9905007	PARAFUSO 4 X 12 MM PANELA PHILIPS	PANHEAD SCREW	TORNILHO CABEZERA DE OLHA	68
H	9905045	PARAFUSO 4 X 45 MM CHATA PHILIPS	PHILIPS FLAT HEAD SCREW	TORNILLO CHATA PHILIPS	38
HB	9918006	PE 47 X 47 X 100 MM PLASTICO ECONOMICO	PLASTIC FOOT	PATA DE PLASTICO	6
L	9920011	CAVILHAS 6 X 30 MM	WOODEN PEG	CLAVIJA DE MADERA	48
LA	9917015	ESPELHO 1200 X 350 X 3 MM FURADO	MIRROR	ESPEJO	1
M	9920012	CAVILHAS 6 X 50 MM	WOODEN PEG	CLAVIJA DE MADERA	10
N	9913006	CORREDICA 350 MM METAL NORMAL	METAL SLIDE	RIEL METALICO	4
OA	9912006	SACHET DE COLA 10 GRAMAS	GLUE	COLA	2
P	9920020	DOBRADICA ALTA 26 MM ESTAMPADA	HINGE	BISAGRA	17
Q	9920005	CALCO DOBRADICA 5 MM	CHOCK	CALCE	17
QB	9905029	PARAFUSO 3.5 X 16 MM CHATA PHILIPS	PHILIPS FLAT HEAD SCREW	TORNILLO CHATA PHILIPS	2
QB	9920063	BUCHA PARA FIXACAO DE ESPELHO	MIRROR BUSHING BUSHING	CASQUILLO DE RETROVISOR	2
R	9920025	FIXADOR 90 GRAUS	90 DEGREE FASTENER	FIJADOR 90 GRADOS	8
S	9920026	FIXADOR DE FUNDO 10 X 10 MM	BOOTOM FASTENER	FIJADOR DE FONDO	50
S3	9920038	SUPORTE CABIDE OBILONGO 20 MM	HANGER SUPPORT	SOPORTE DE PERCHERO	4
V	9920030	PORCA CILINDRICA 9 X 12 MM	CYLINDRICAL NUT	TUERCA CILINDRICA	38
X	9906002	PREGO 9X9 MM	NAIL	CLAVO	120
Y	9920006	CANTONEIRA METALICA 16 MM	METAL ANGLE BRACKET	ESQUINERAS METALICAS	19

Acessórios/Accessories/Accessorios

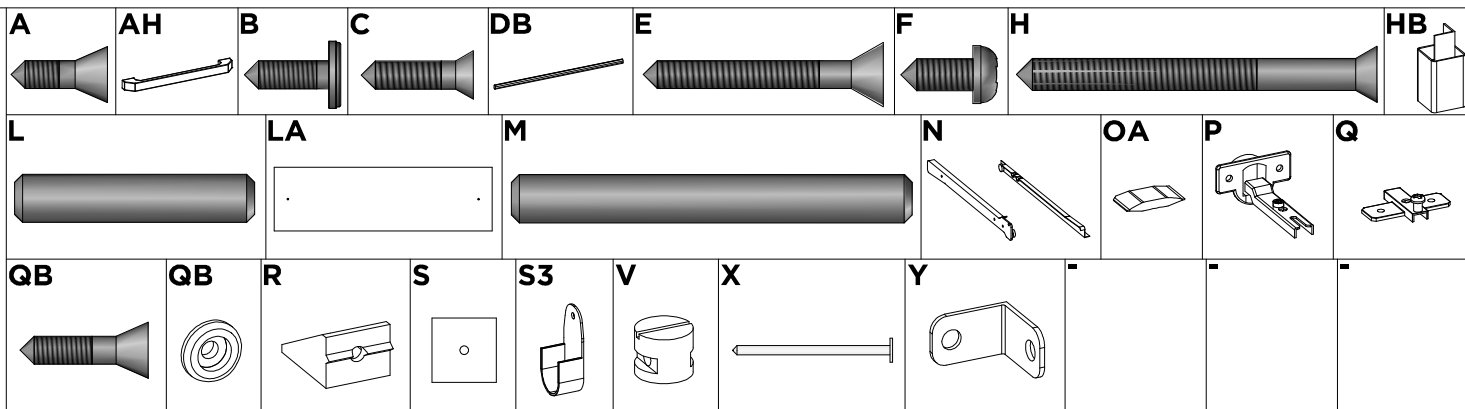

# 01

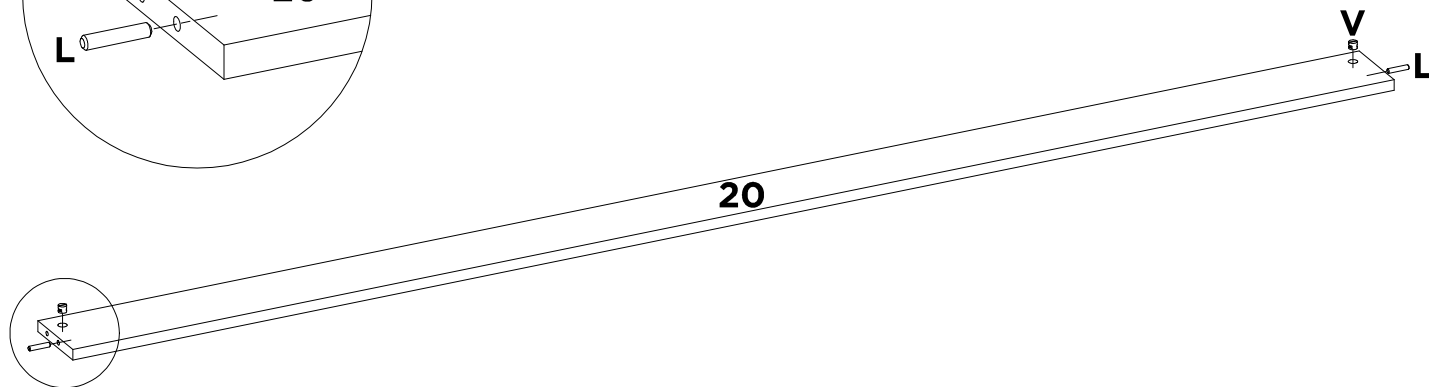
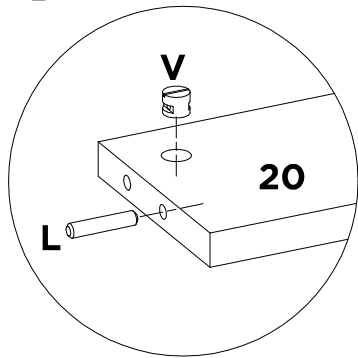

L	V	-	-	-	-	-	-
X2	X2	-	-	-	-	-	-

# 01A

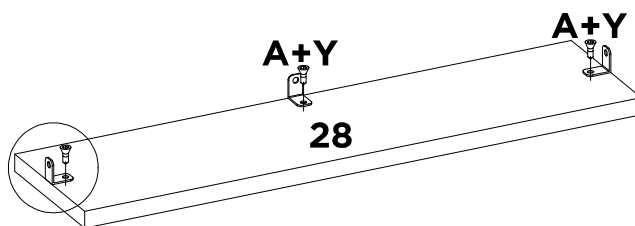
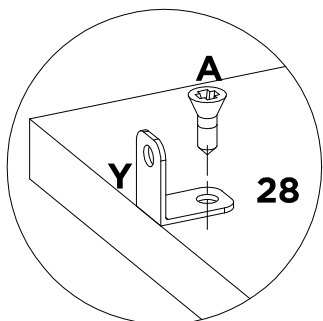
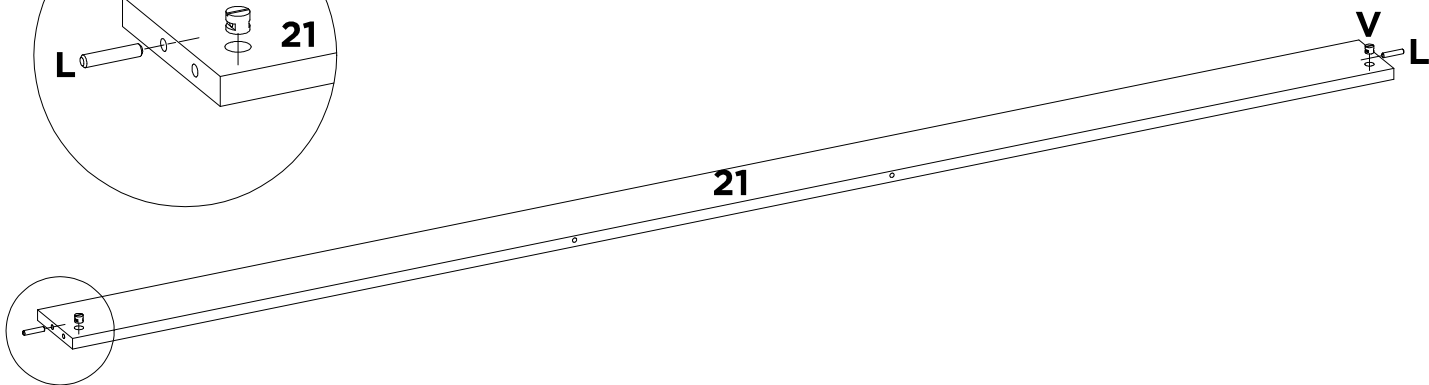
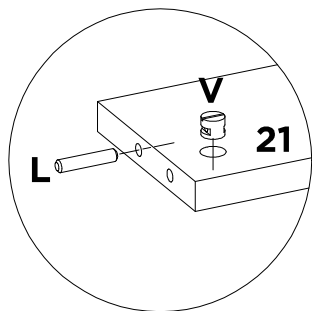

A	L	V	Y	-	-	-	-
X3	X2	X2	X3	-	-	-	-

# 02

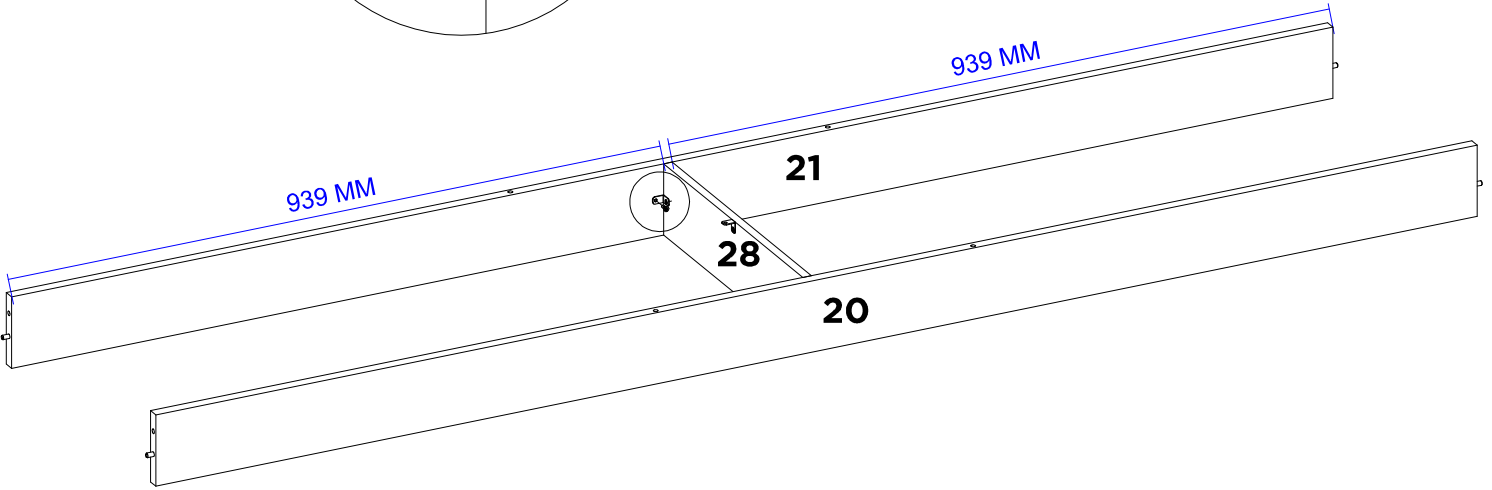
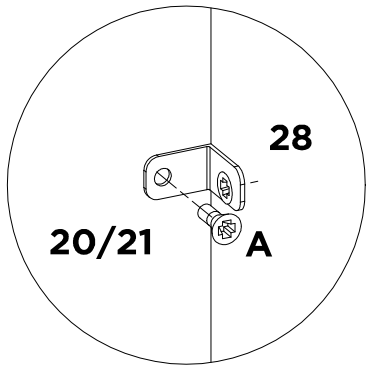

<b>A</b>	-	-	-	-	-	-	-
<b>X2</b>	-	-	-	-	-	-	-

# 03

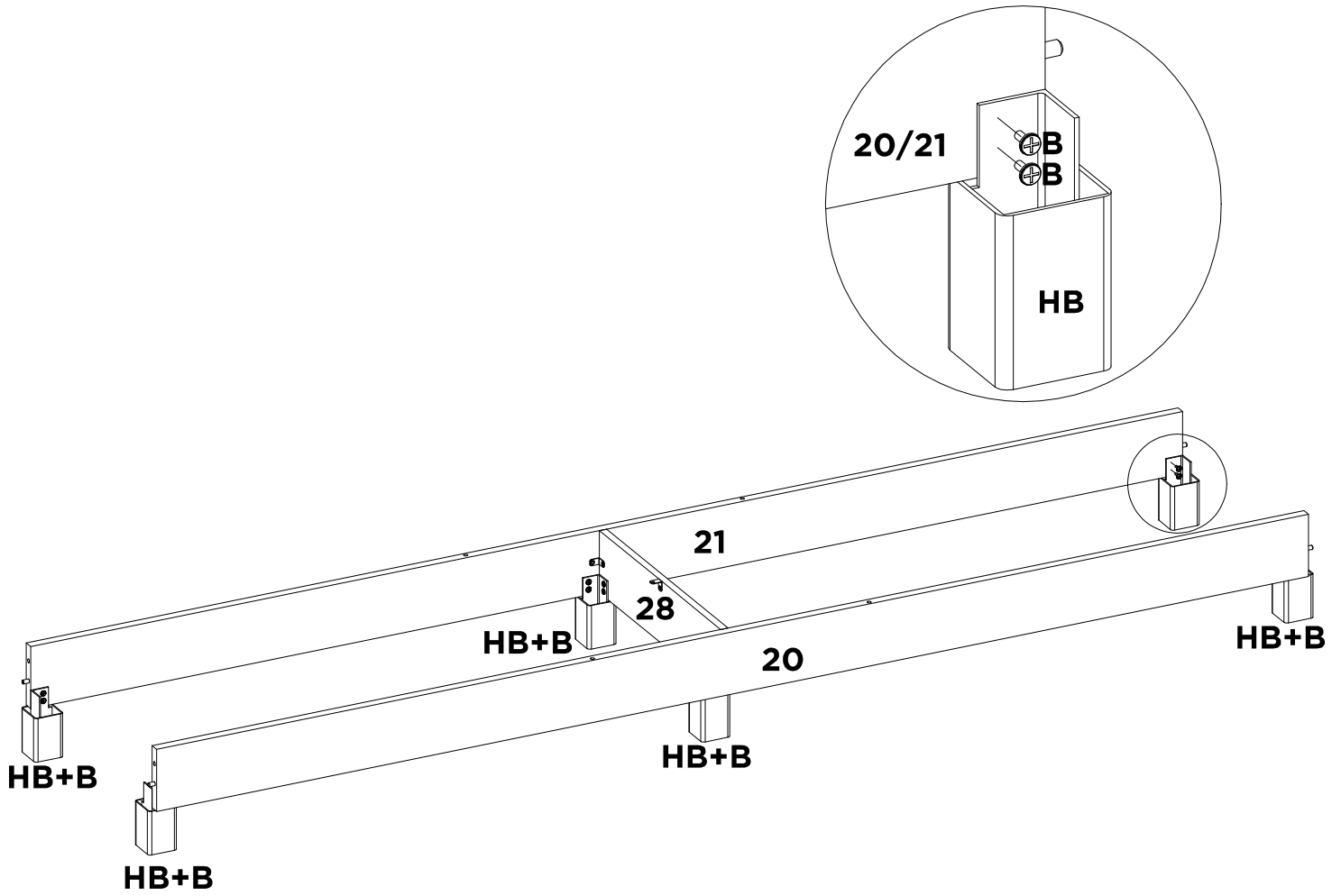

<b>B</b>	<b>HB</b>	-	-	-	-	-	-
<b>X24</b>	<b>X6</b>	-	-	-	-	-	-

# 04

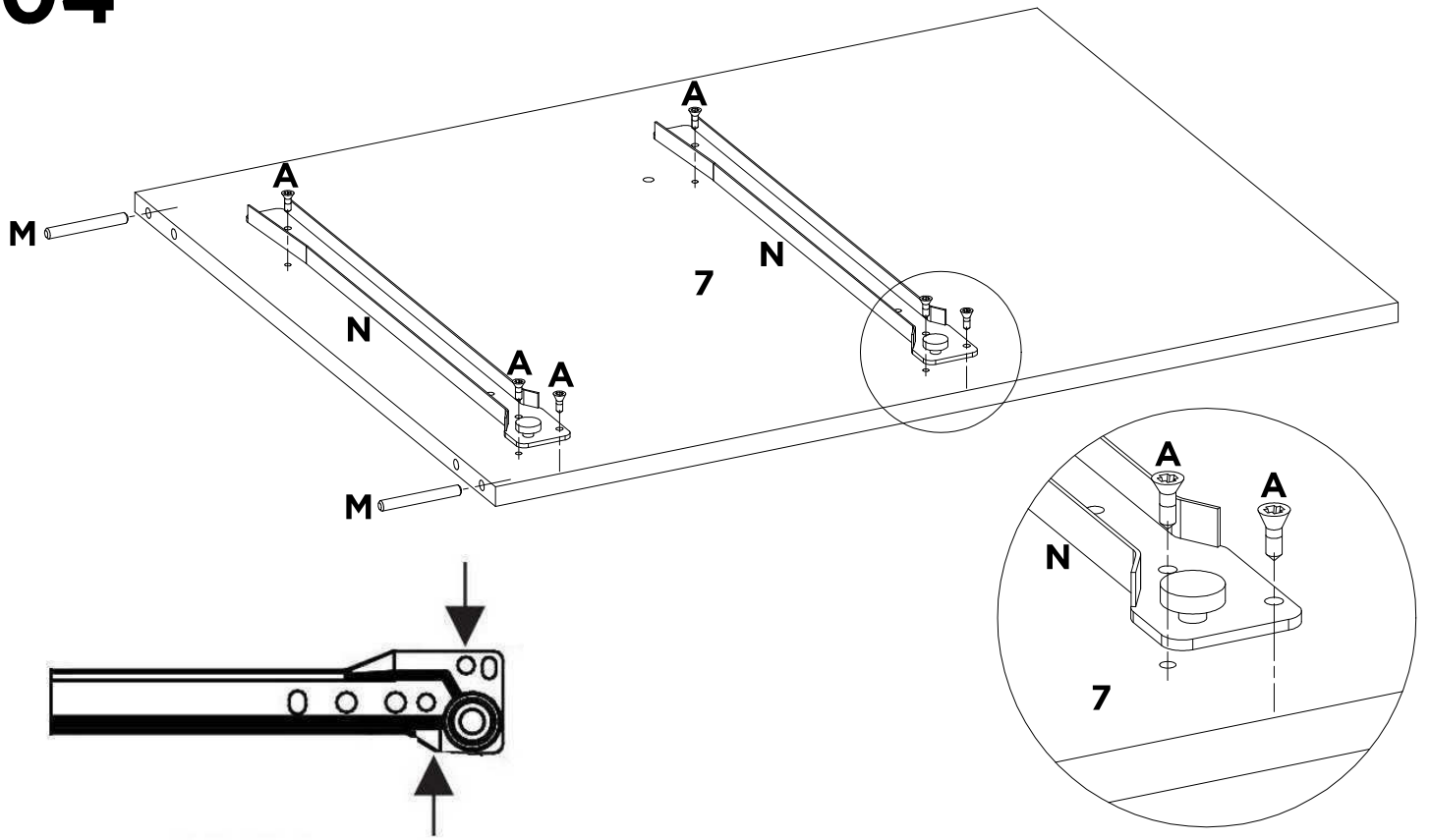

<b>A</b>	<b>M</b>	<b>N</b>	-	-	-	-	-
<b>X6</b>	<b>X2</b>	<b>X2</b>	-	-	-	-	-

# 04A

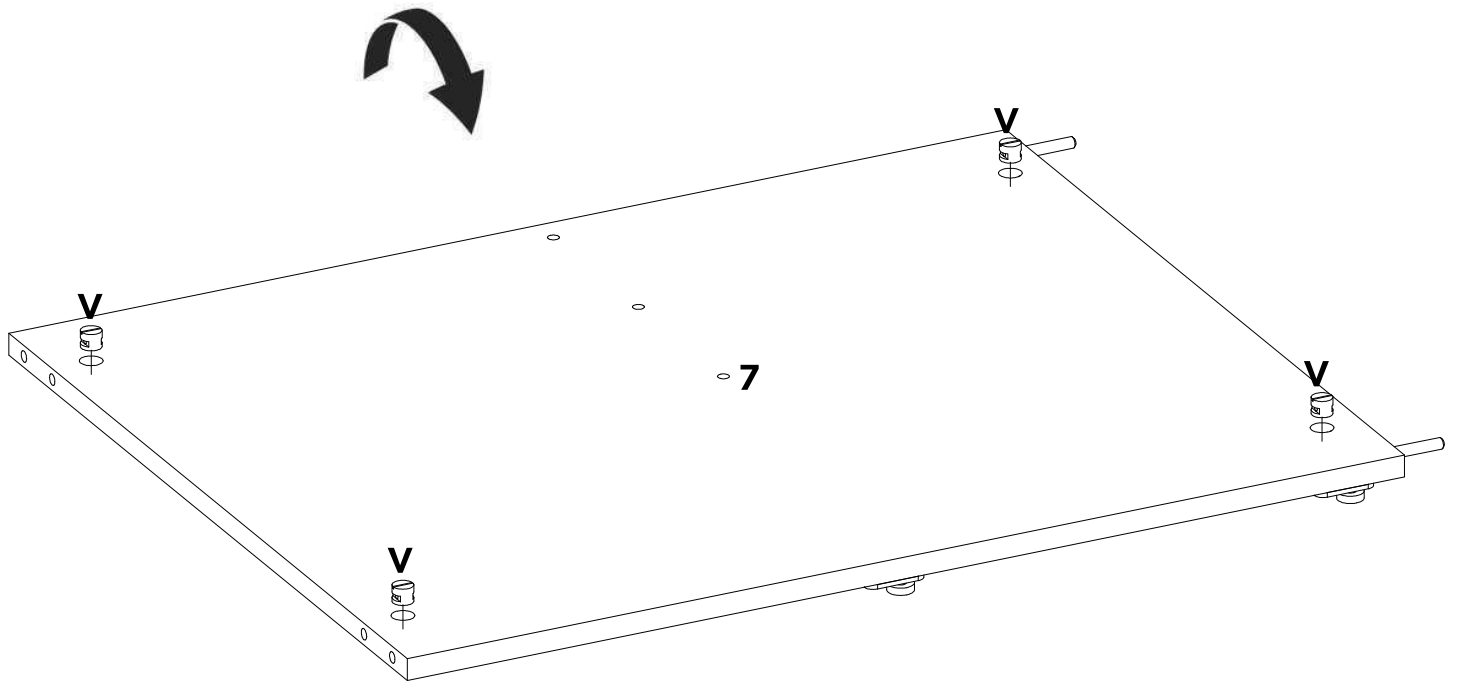

<b>V</b>	-	-	-	-	-	-	-
<b>X4</b>	-	-	-	-	-	-	-

# 05

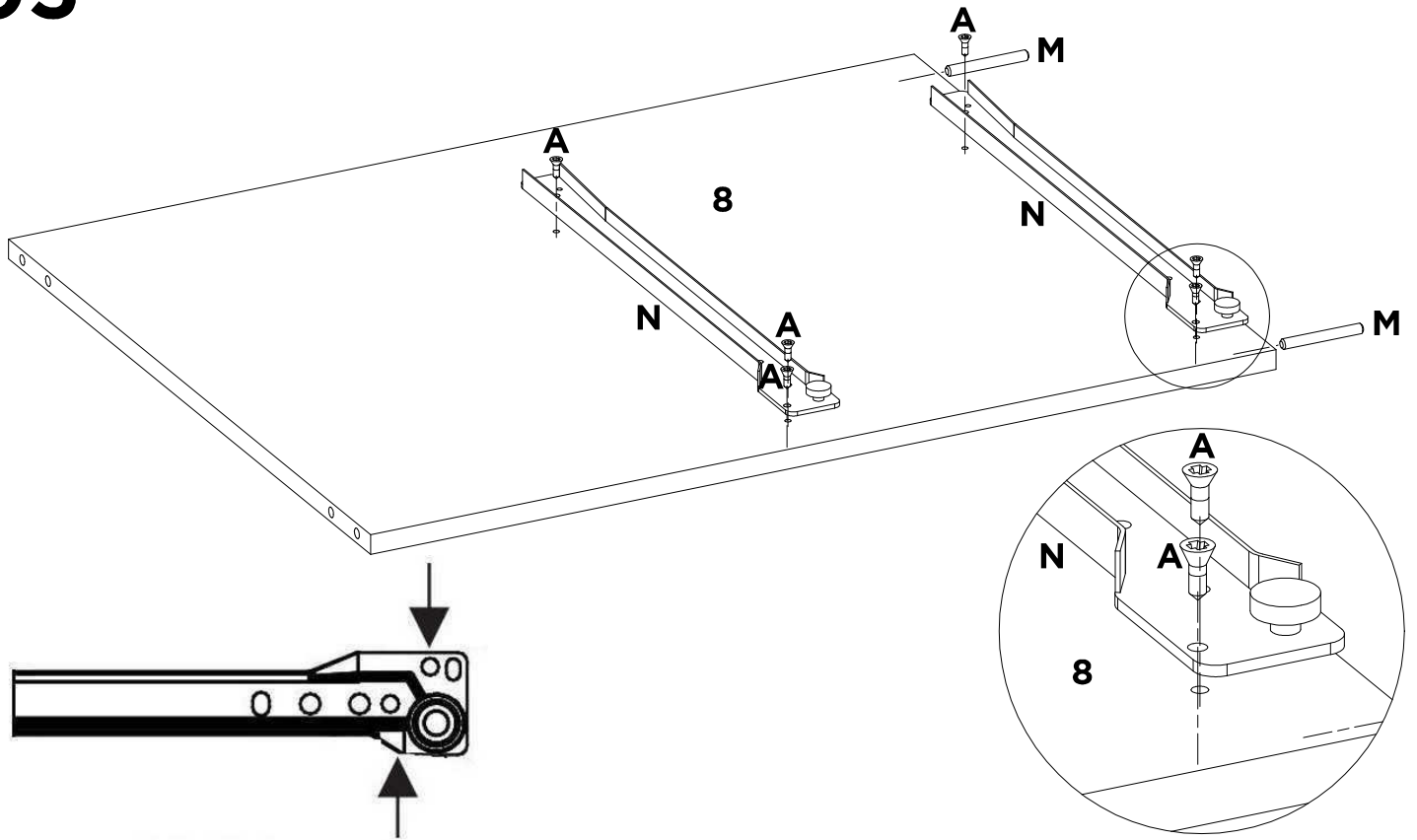

A	M	N	-	-	-	-	-
X6	X2	X2	-	-	-	-	-

# 05A

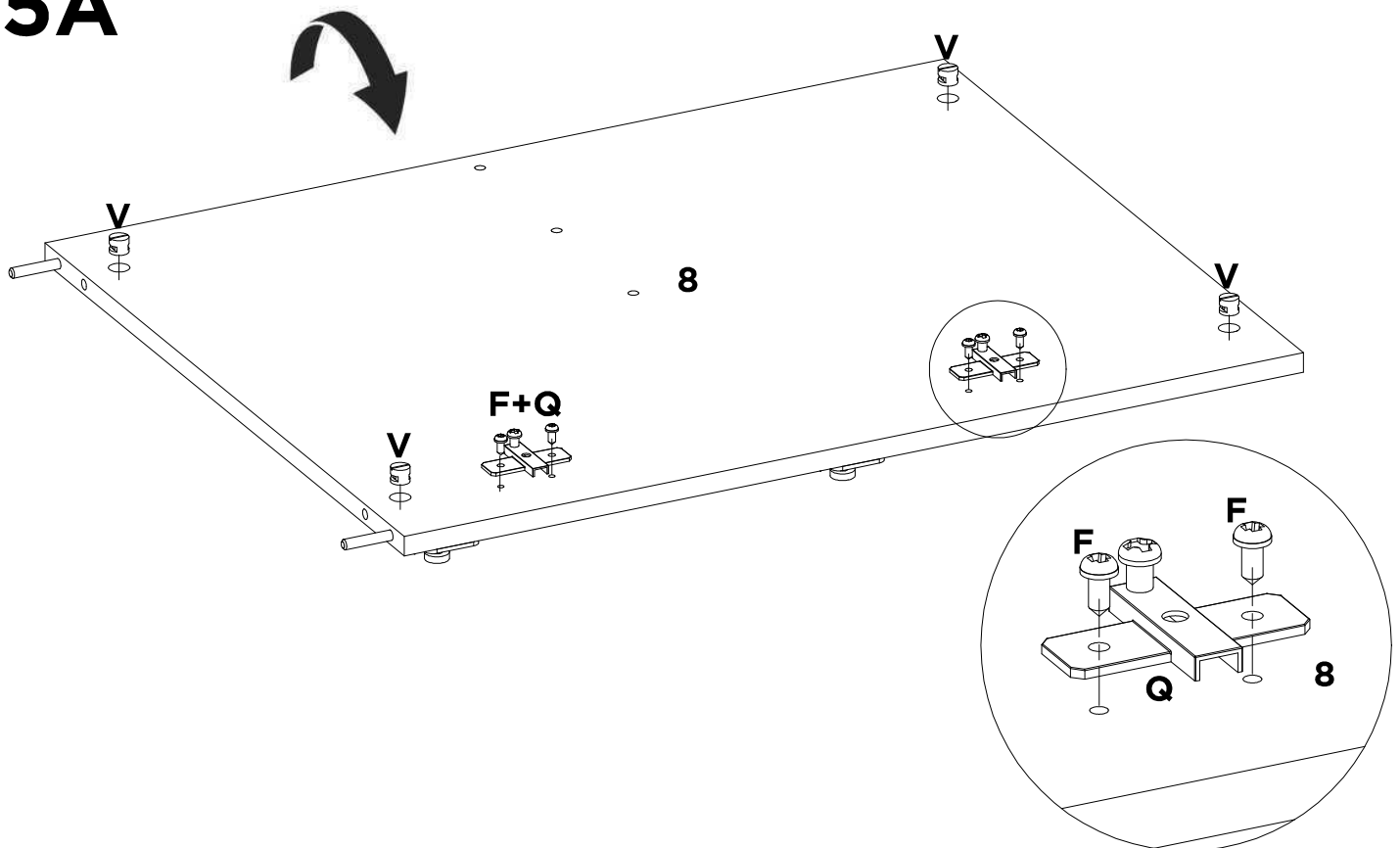

F	Q	V	-	-	-	-	-
X4	X2	X4	-	-	-	-	-



# 06

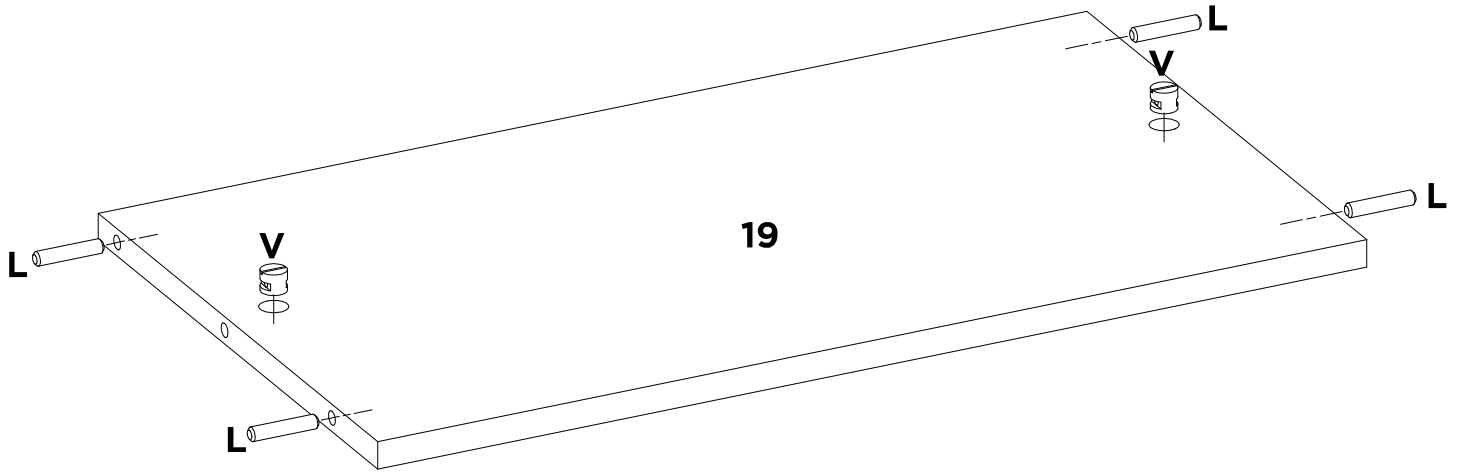

<b>L</b>	<b>V</b>	-	-	-	-	-	-
<b>X4</b>	<b>X2</b>	-	-	-	-	-	-

# 07

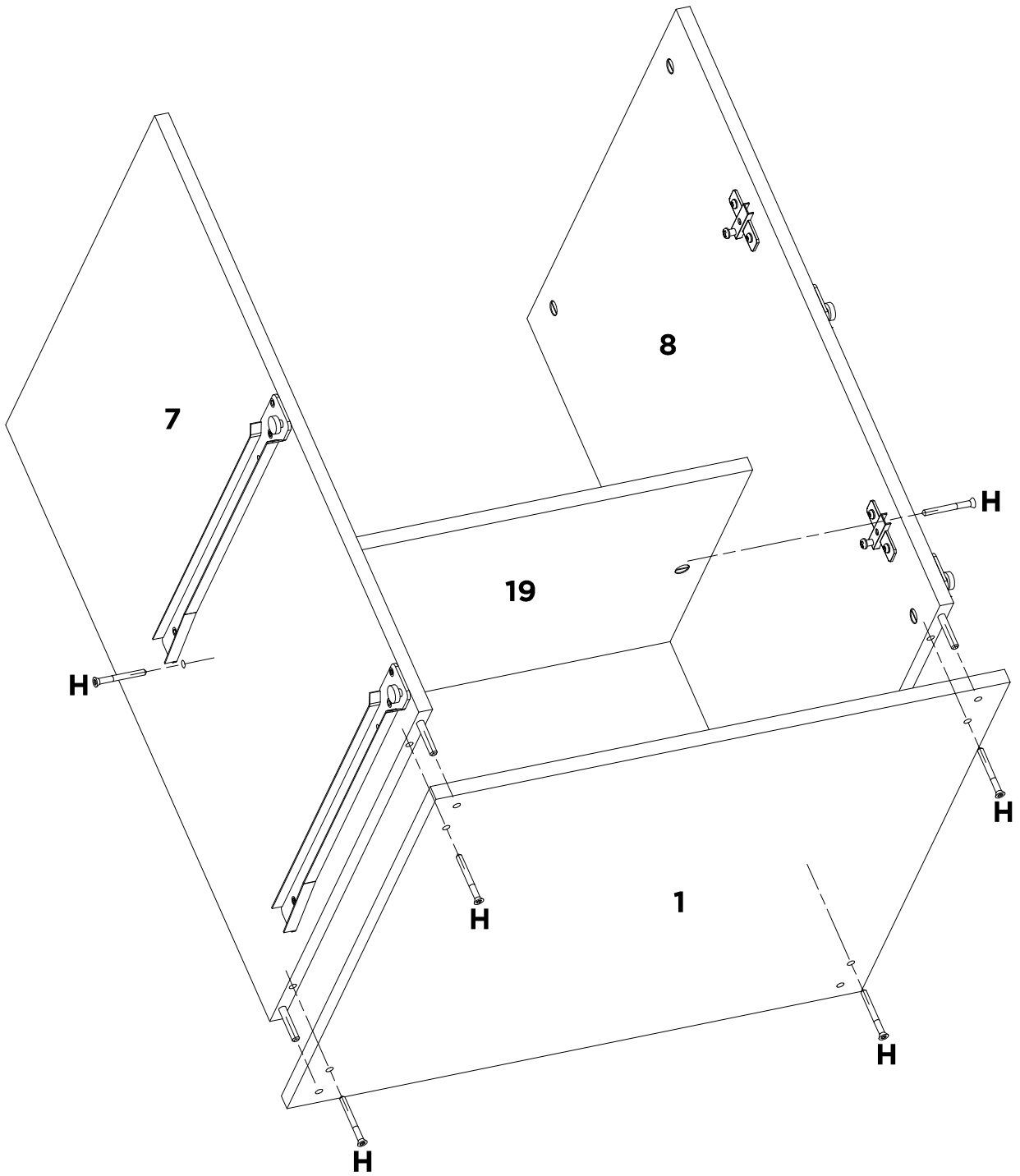

H

X6

-	-	-	-	-	-	-	-
-	-	-	-	-	-	-	-

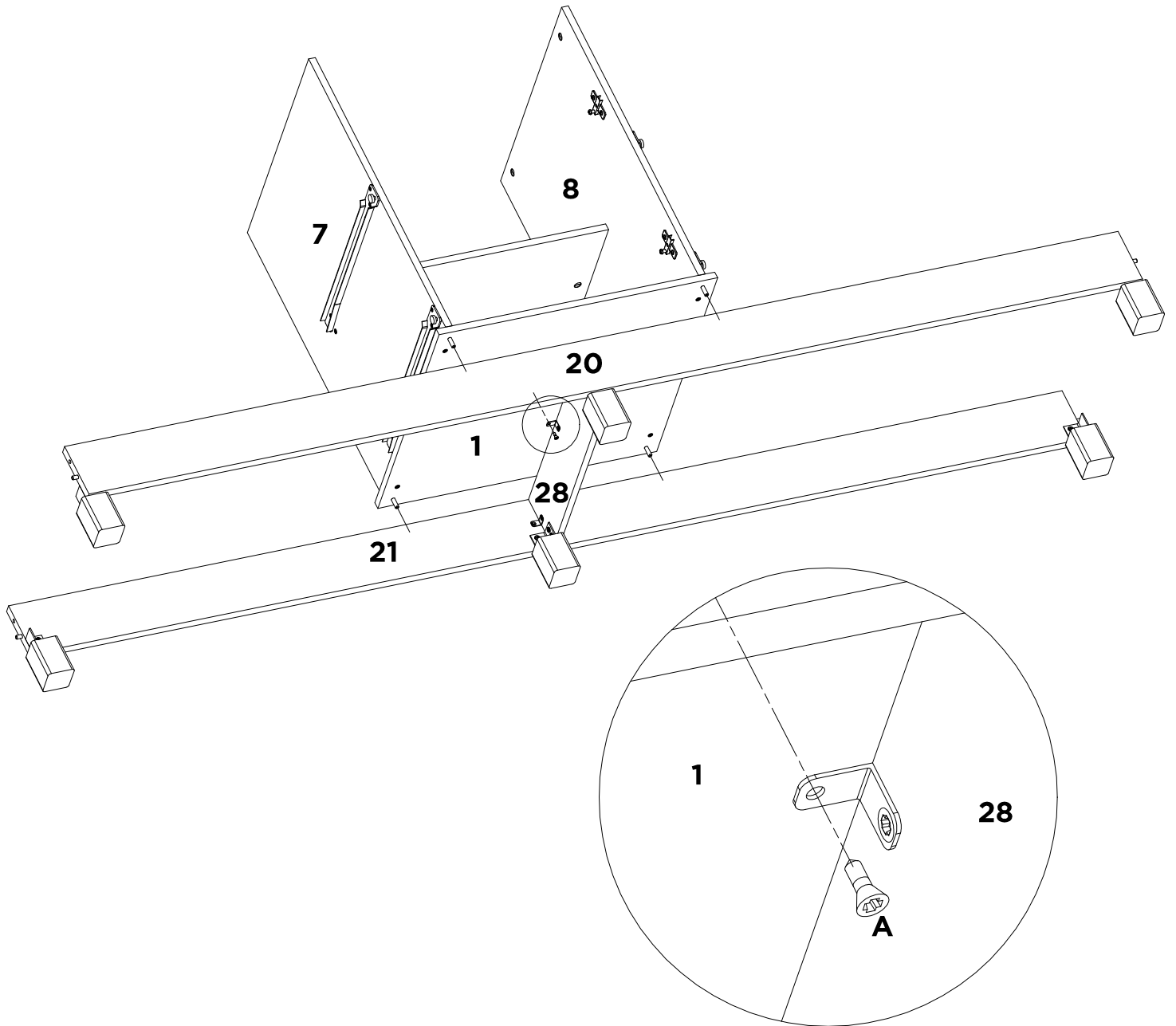

<b>A</b>	-	-	-	-	-	-	-
<b>X1</b>	-	-	-	-	-	-	-

# 09

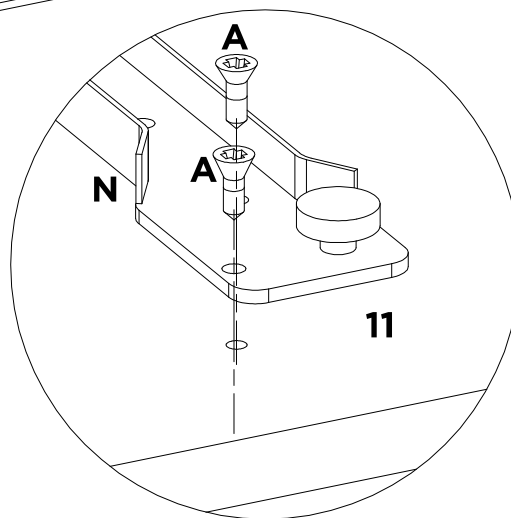
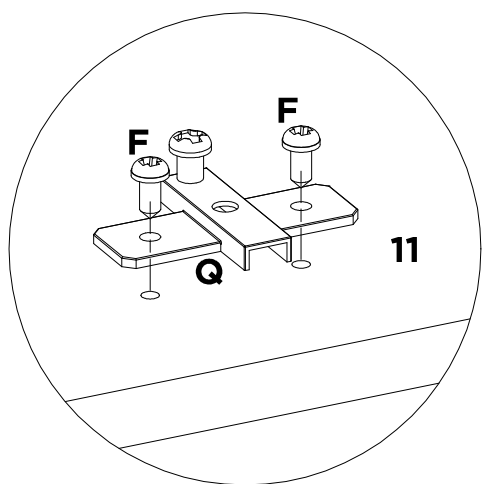
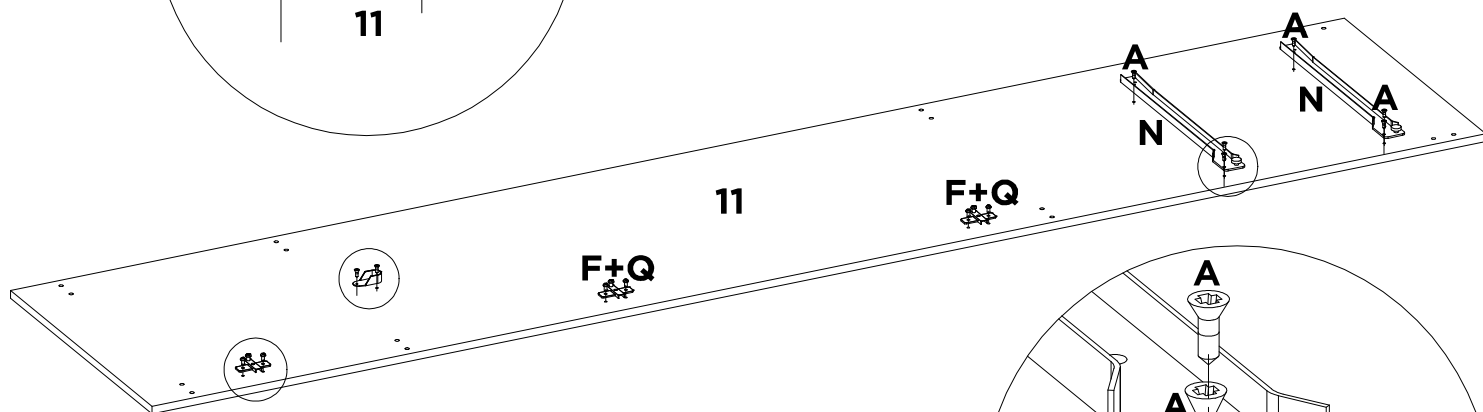
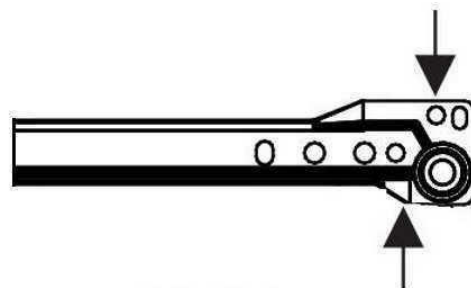
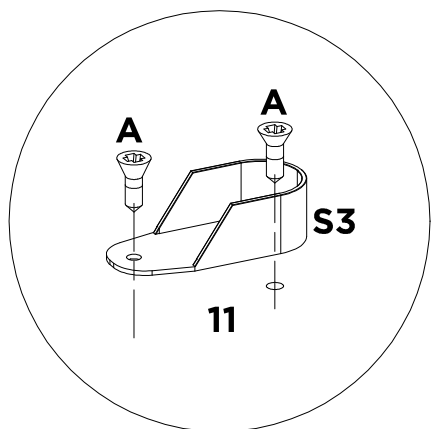

<b>A</b>	<b>F</b>	<b>N</b>	<b>Q</b>	<b>S3</b>	-	-	-
<b>X8</b>	<b>X6</b>	<b>X2</b>	<b>X3</b>	<b>X1</b>	-	-	-

# 10

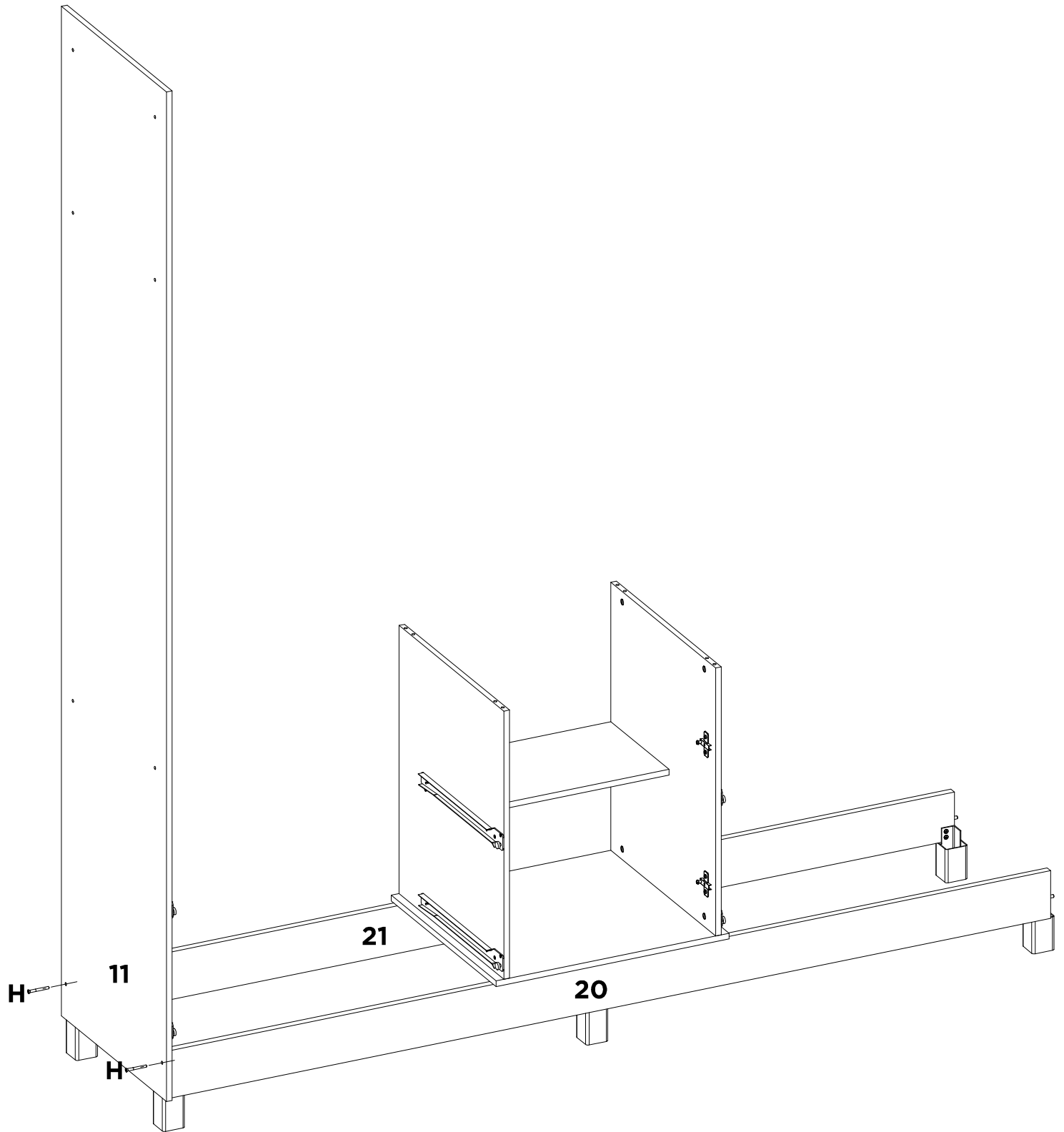

<b>H</b>	-	-	-	-	-	-	-
<b>X2</b>	-	-	-	-	-	-	-

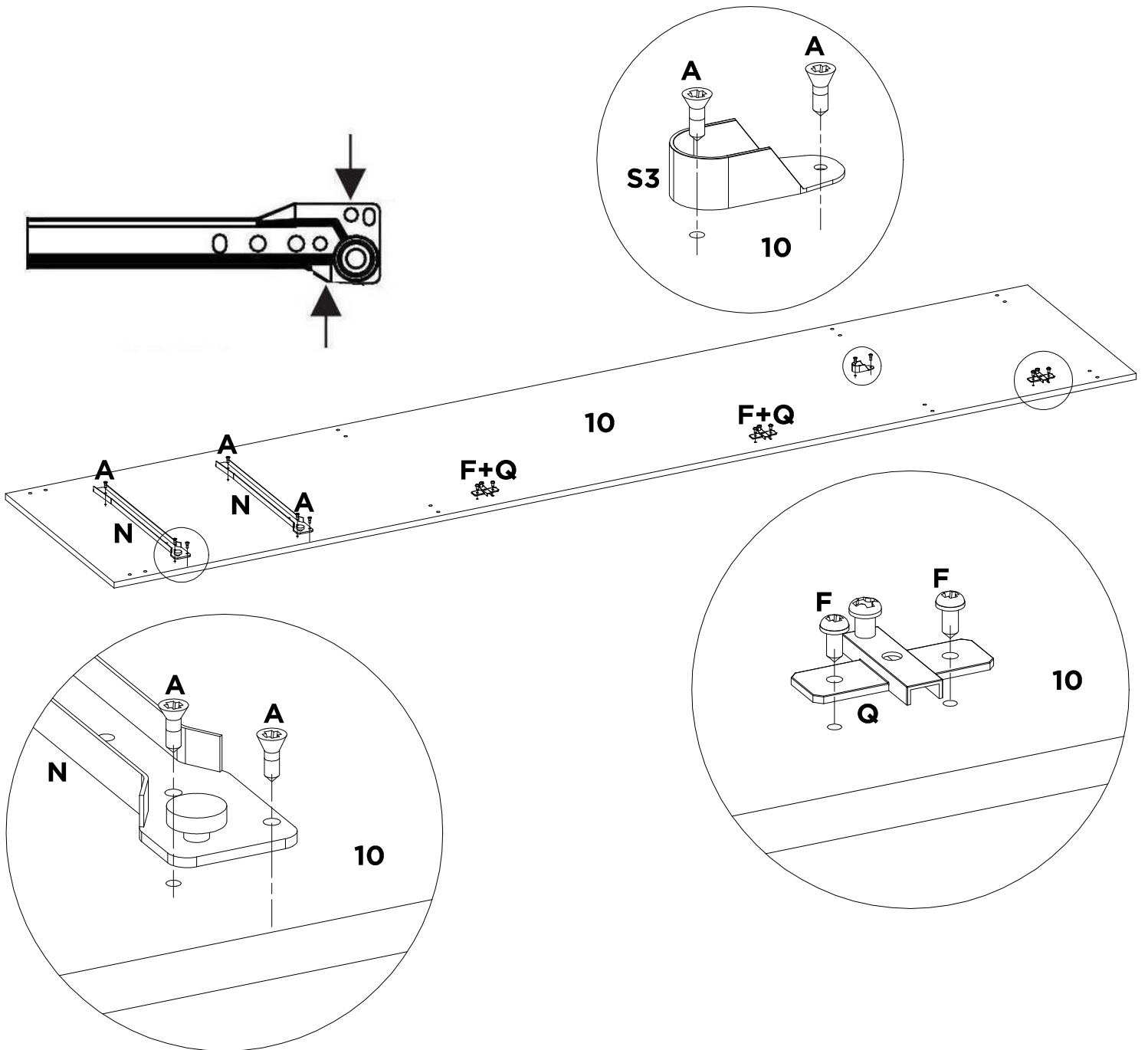

<b>A</b>	<b>F</b>	<b>N</b>	<b>Q</b>	<b>S3</b>	-	-	-
<b>X8</b>	<b>X6</b>	<b>X2</b>	<b>X3</b>	<b>X1</b>	-	-	-

# 12

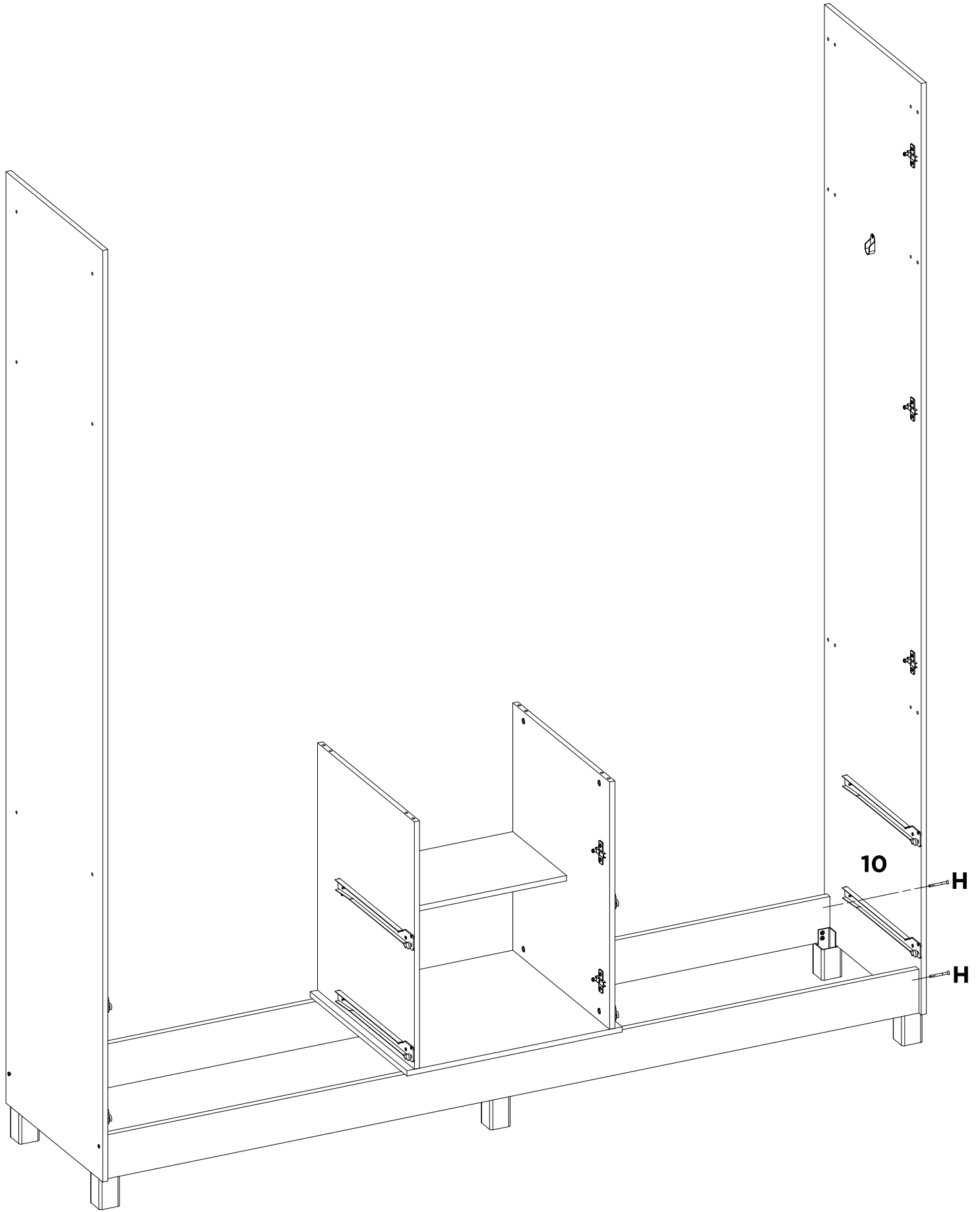

<b>H</b>	-	-	-	-	-	-	-
<b>X2</b>	-	-	-	-	-	-	-

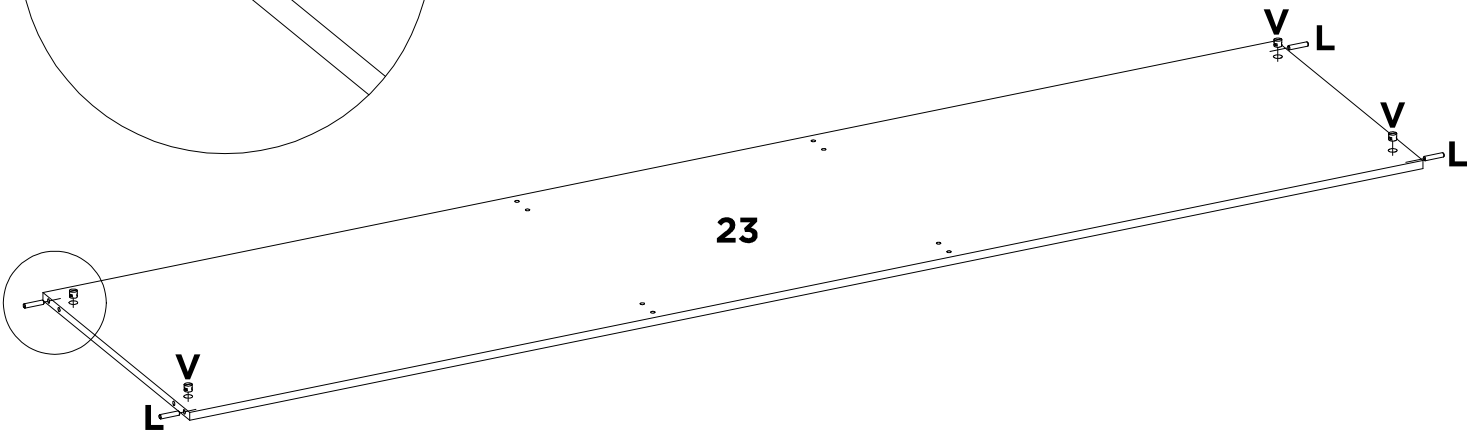
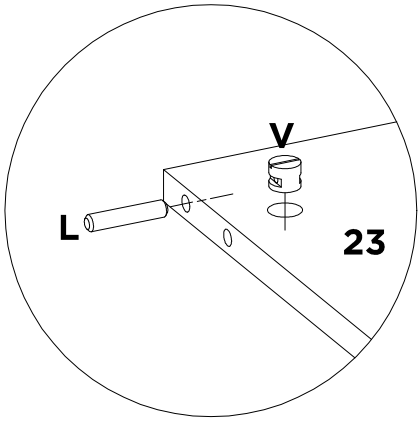

<b>L</b>	<b>V</b>	-	-	-	-	-	-
<b>X4</b>	<b>X4</b>	-	-	-	-	-	-



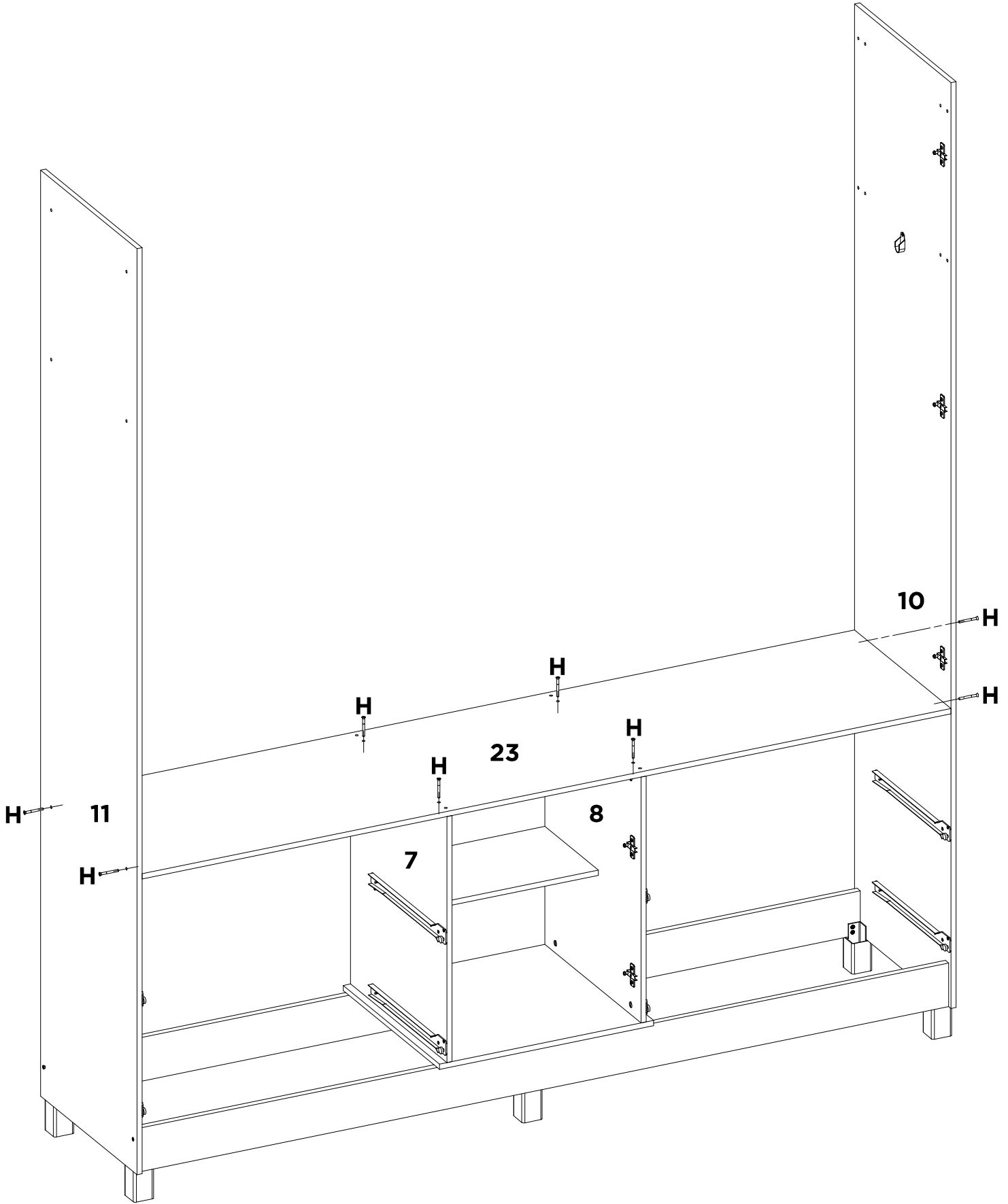

H

X8

-

-

-

-

-

-

-

-

-

-

-

-

-

-

# 15

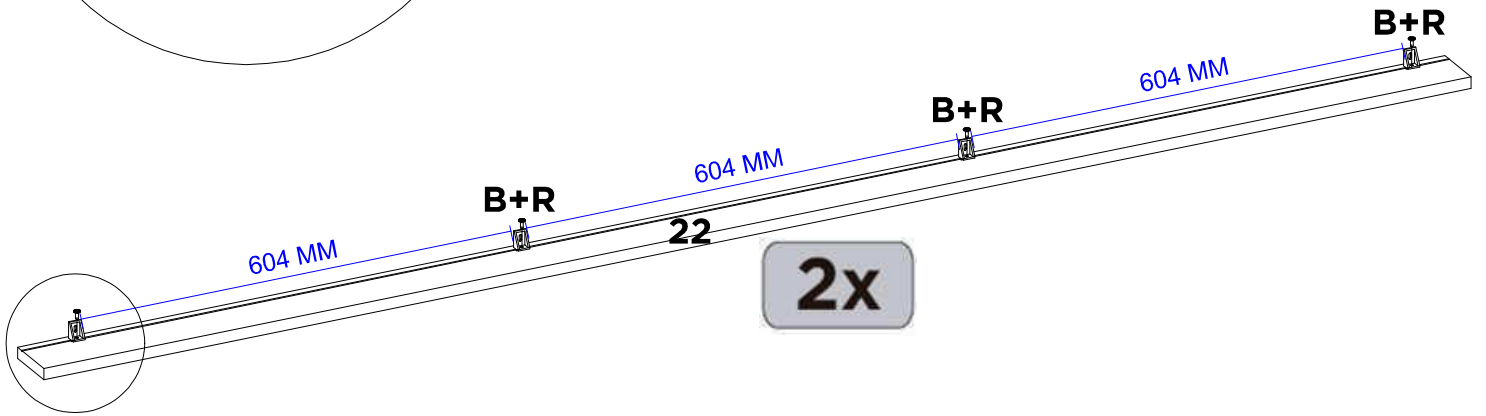
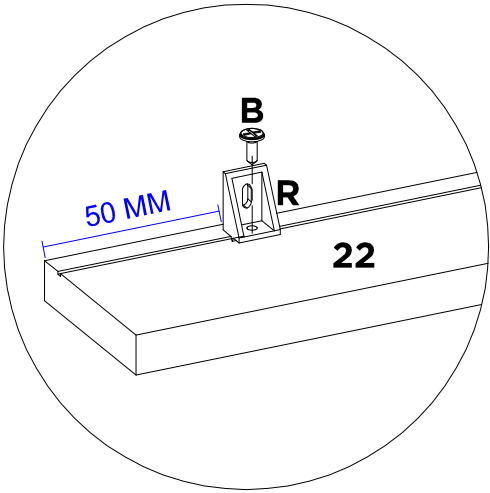

<b>B</b>	<b>R</b>	-	-	-	-	-	-
<b>X8</b>	<b>X8</b>	-	-	-	-	-	-

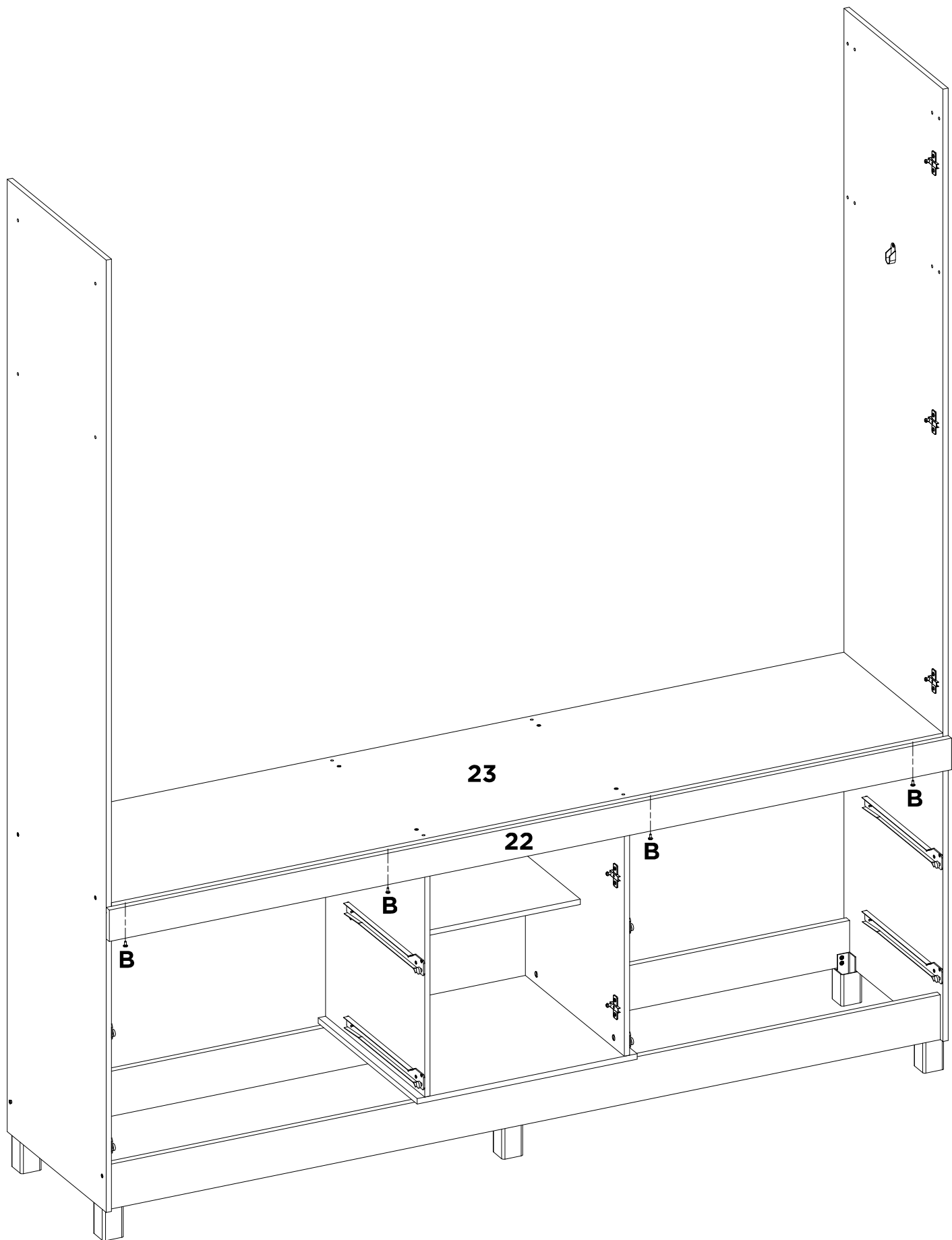

<b>B</b>	-	-	-	-	-	-	-
<b>X4</b>	-	-	-	-	-	-	-

# 17

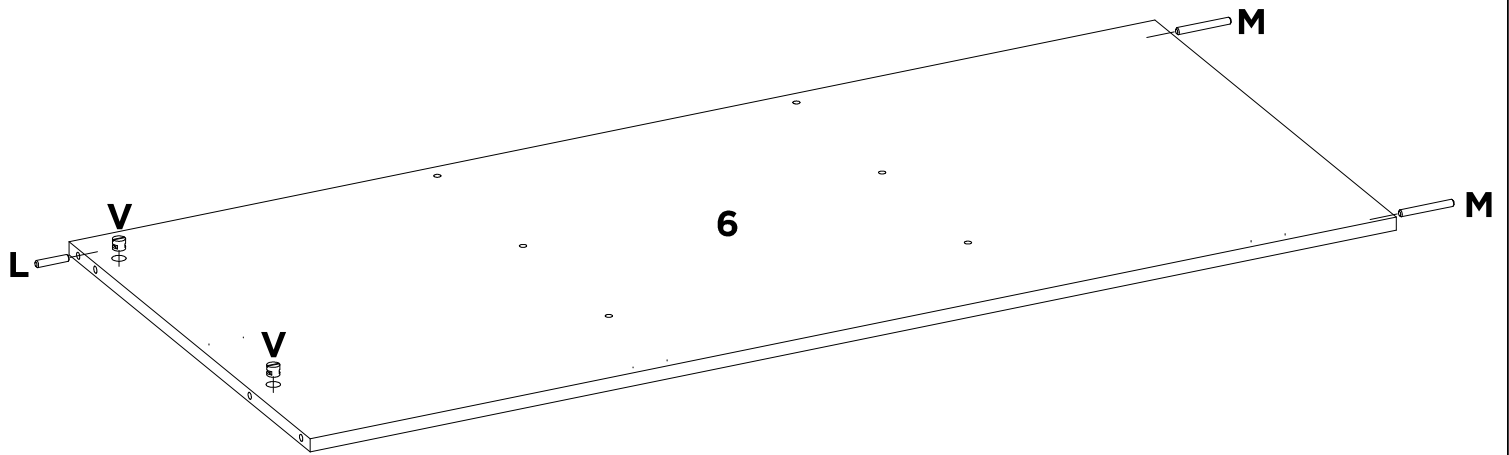

L	M	V	-	-	-	-	-
X1	X2	X2	-	-	-	-	-

# 17A

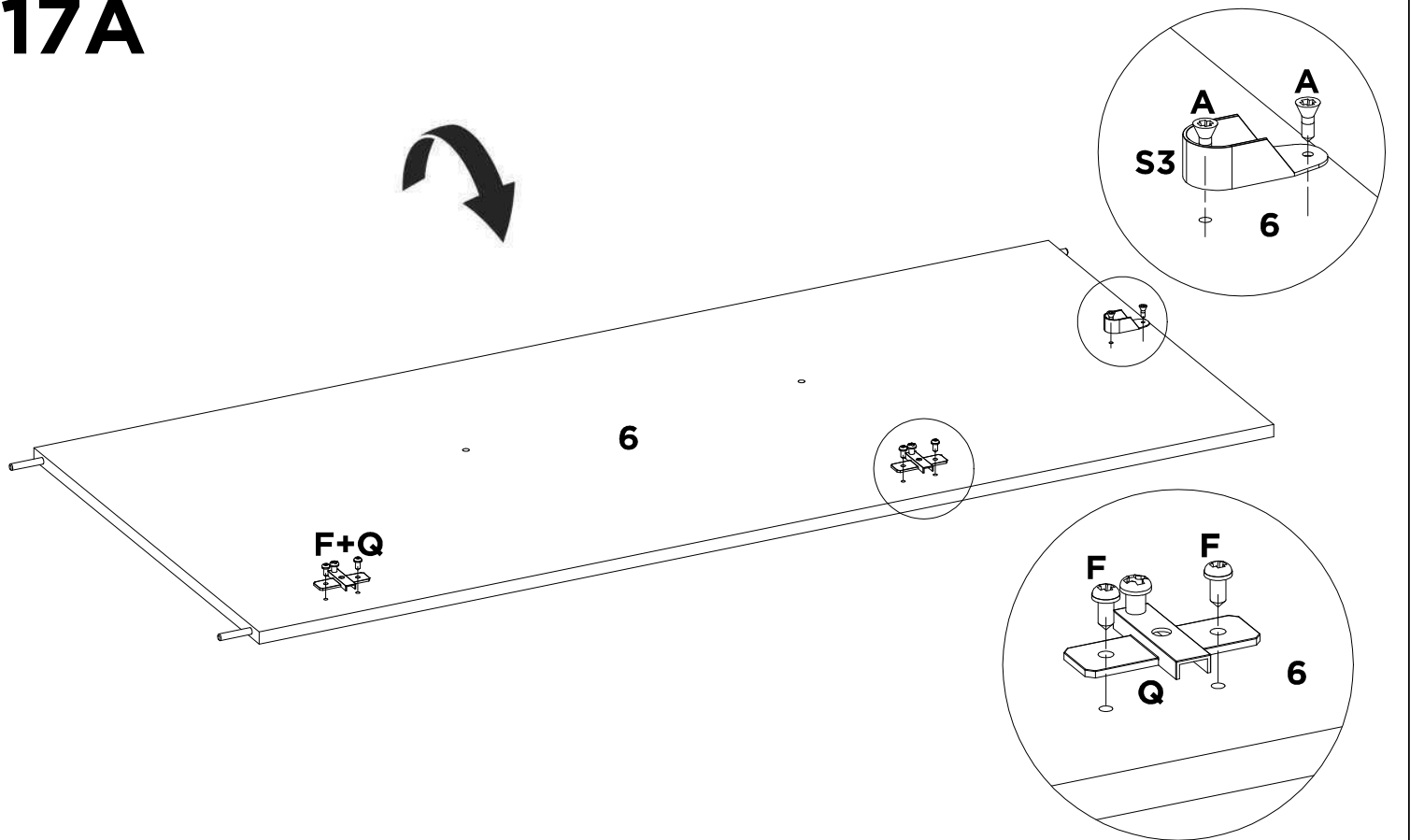

A	F	Q	S3	-	-	-	-
X2	X4	X2	X1	-	-	-	-

# 18

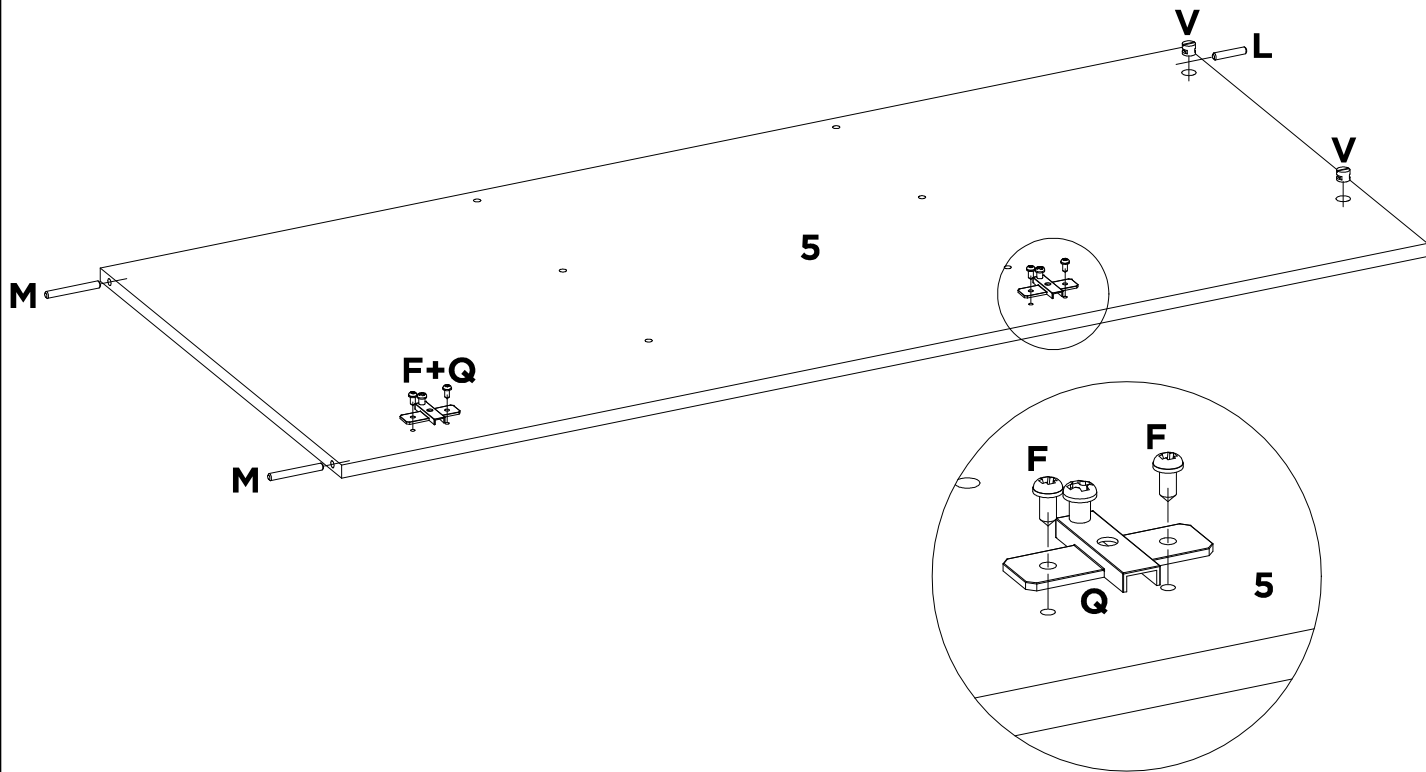

<b>F</b>	<b>L</b>	<b>M</b>	<b>Q</b>	<b>V</b>	-	-	-
<b>X4</b>	<b>X1</b>	<b>X2</b>	<b>X2</b>	<b>X2</b>	-	-	-

# 18A

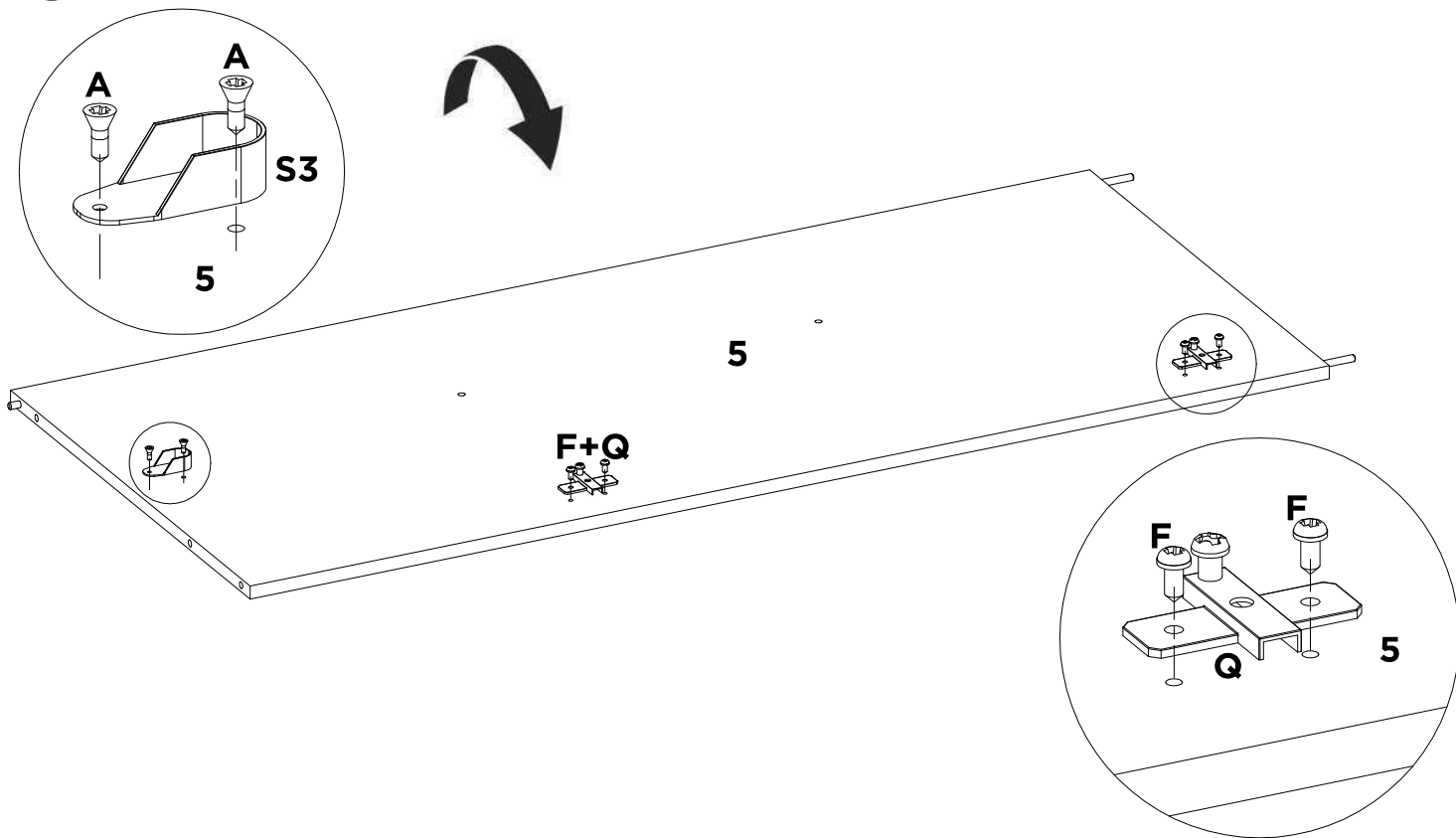

<b>A</b>	<b>F</b>	<b>Q</b>	<b>S3</b>	-	-	-	-
<b>X2</b>	<b>X4</b>	<b>X2</b>	<b>X1</b>	-	-	-	-

# 19

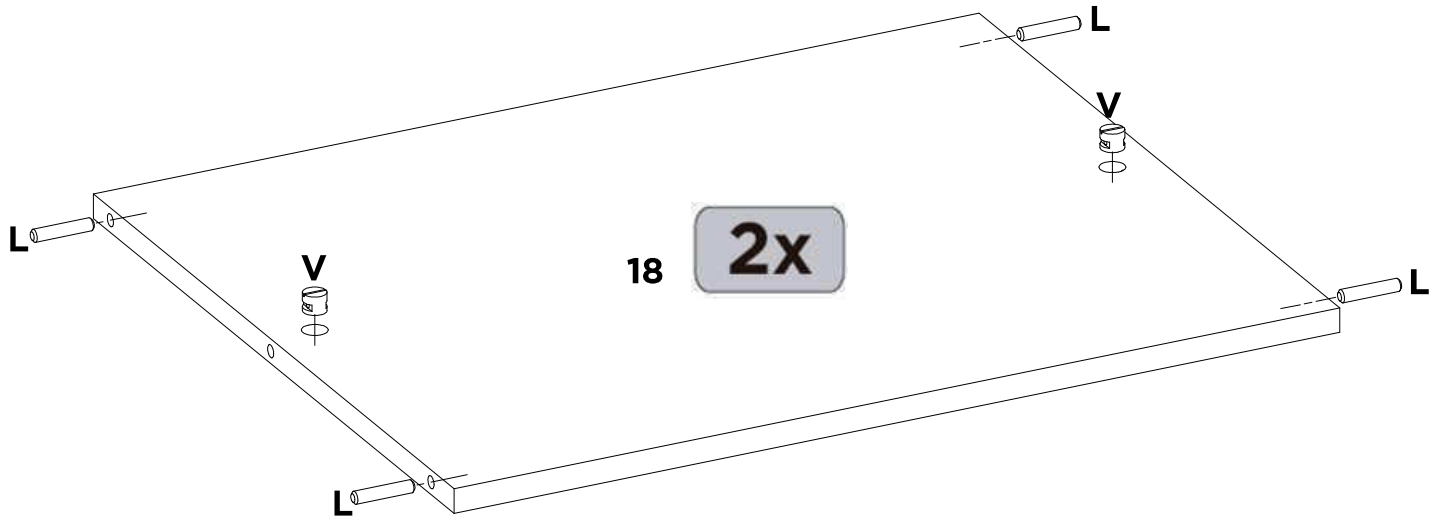

L	V	-	-	-	-	-	-
X8	X4	-	-	-	-	-	-

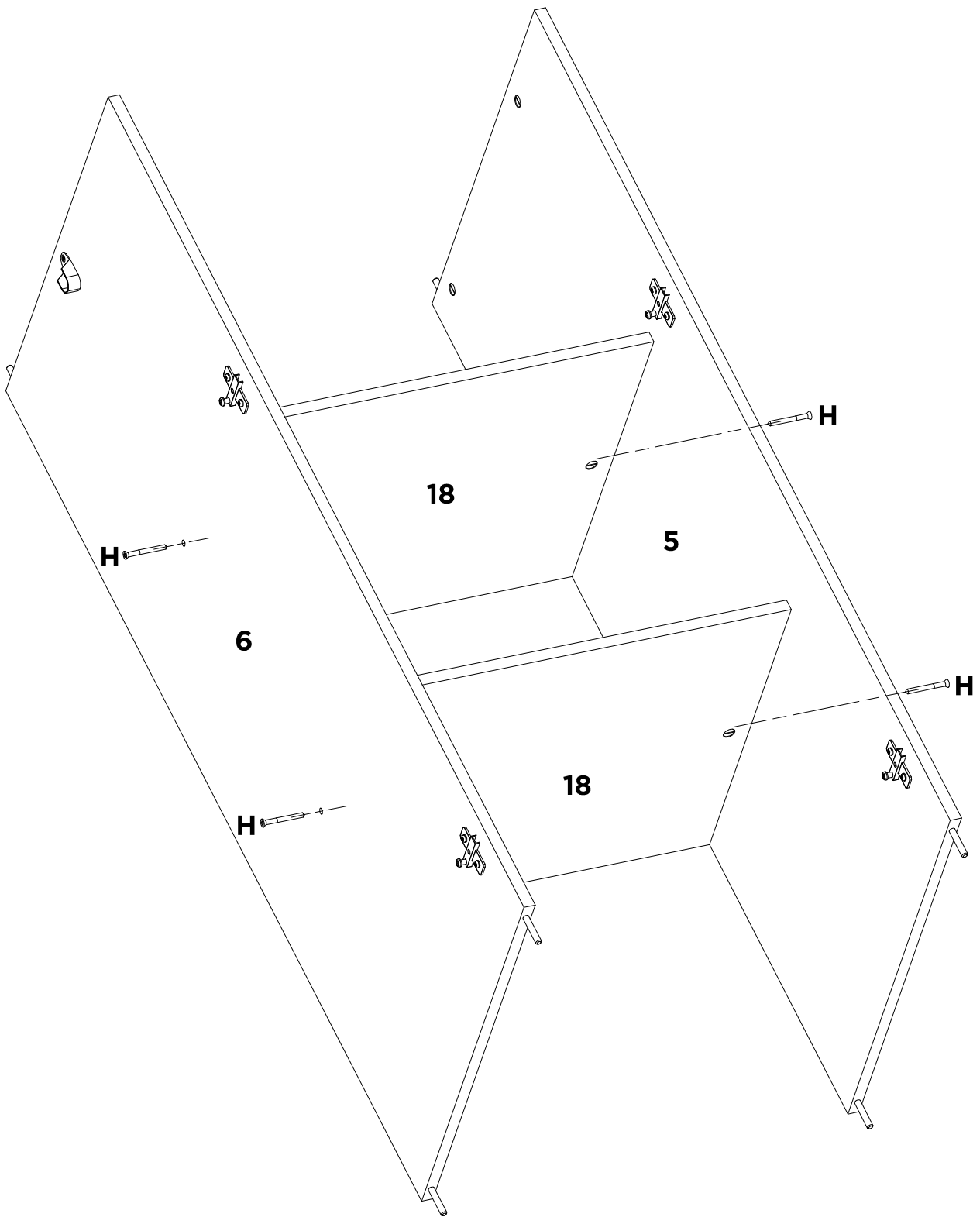

H	-	-	-	-	-	-	-
X4	-	-	-	-	-	-	-

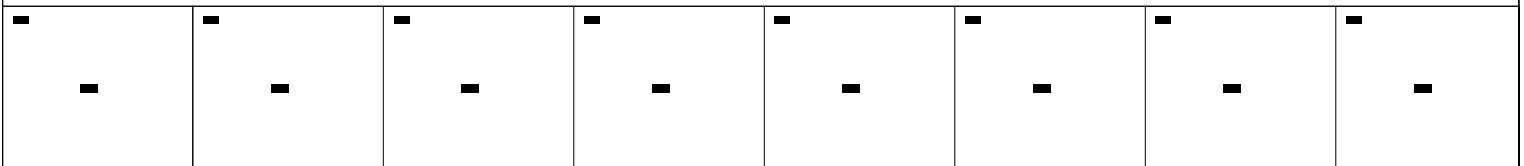
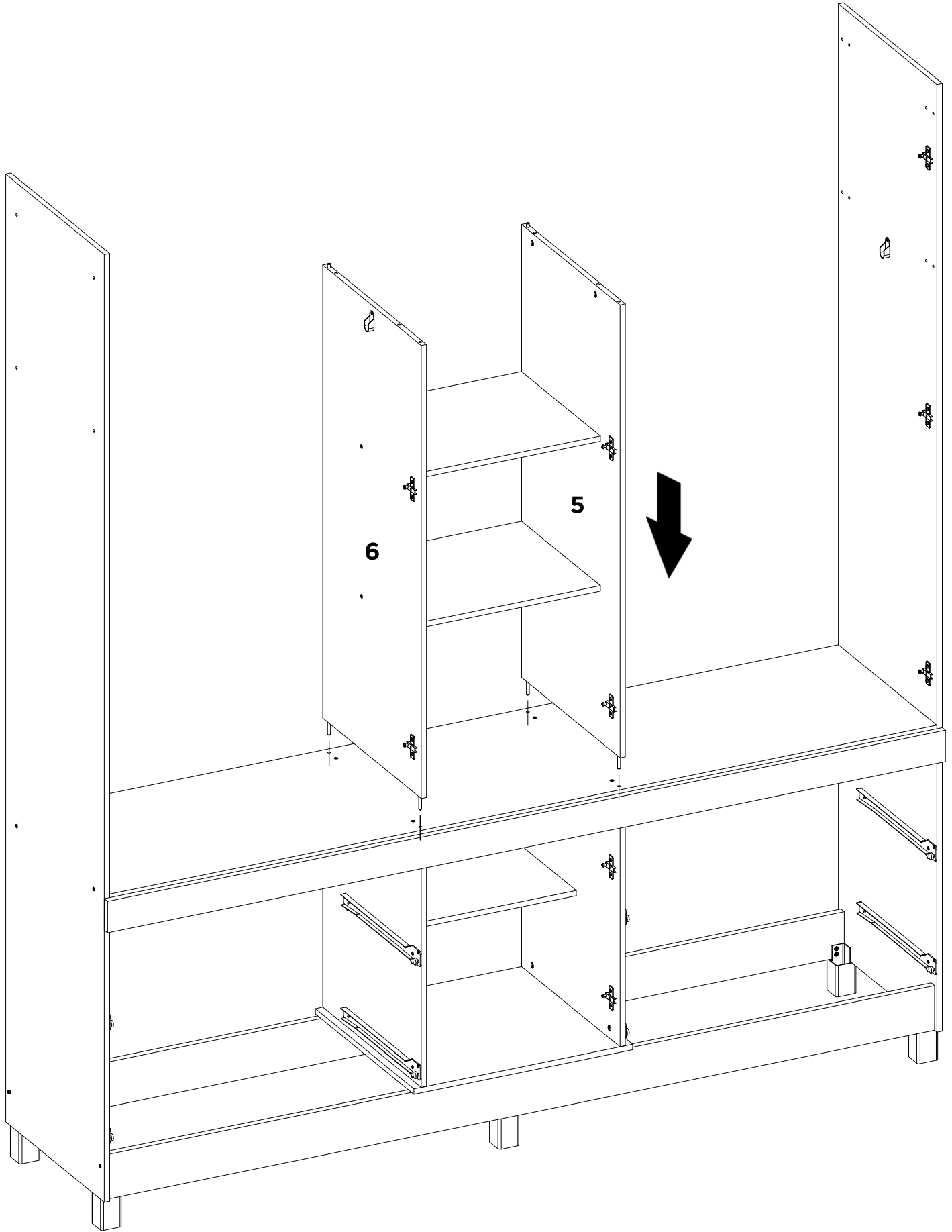



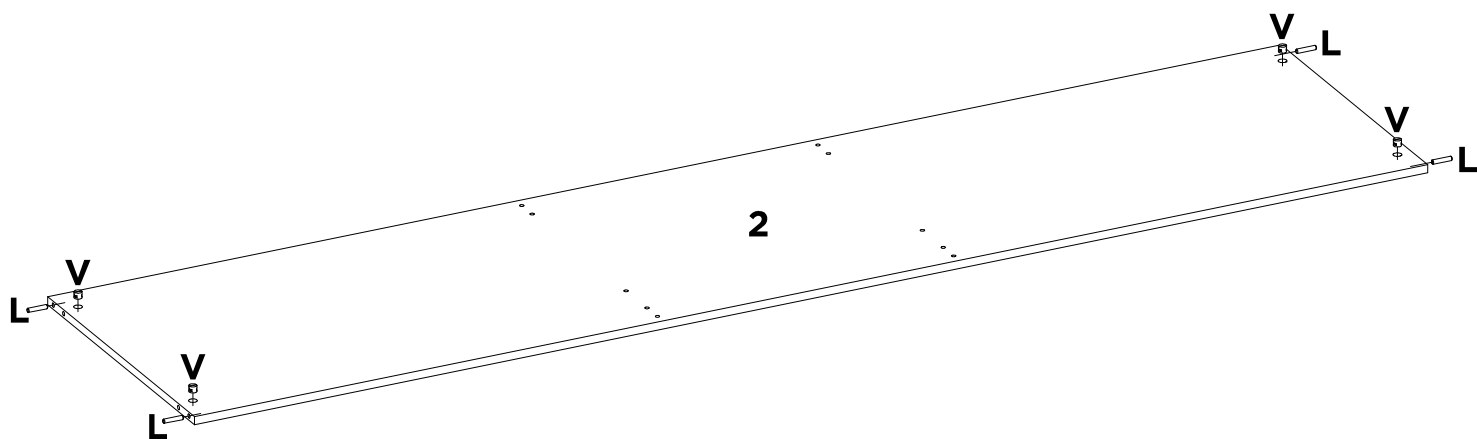

L

X4

V

X4

-

-

-

-

-

-

-

-

-

-

-

-

# 23

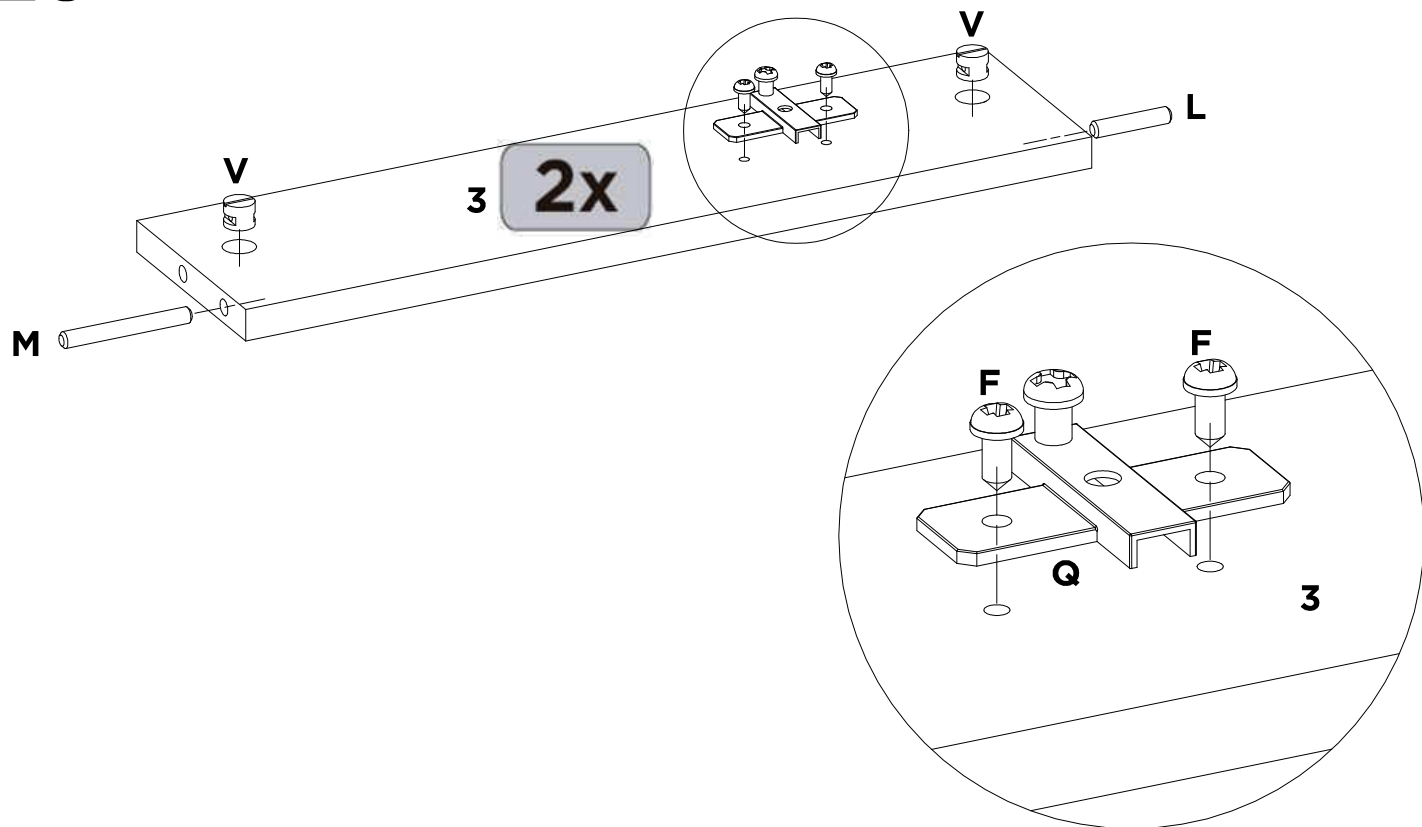

<b>F</b>	<b>L</b>	<b>M</b>	<b>Q</b>	<b>V</b>	-	-	-
<b>X4</b>	<b>X2</b>	<b>X2</b>	<b>X2</b>	<b>X4</b>	-	-	-

# 23A

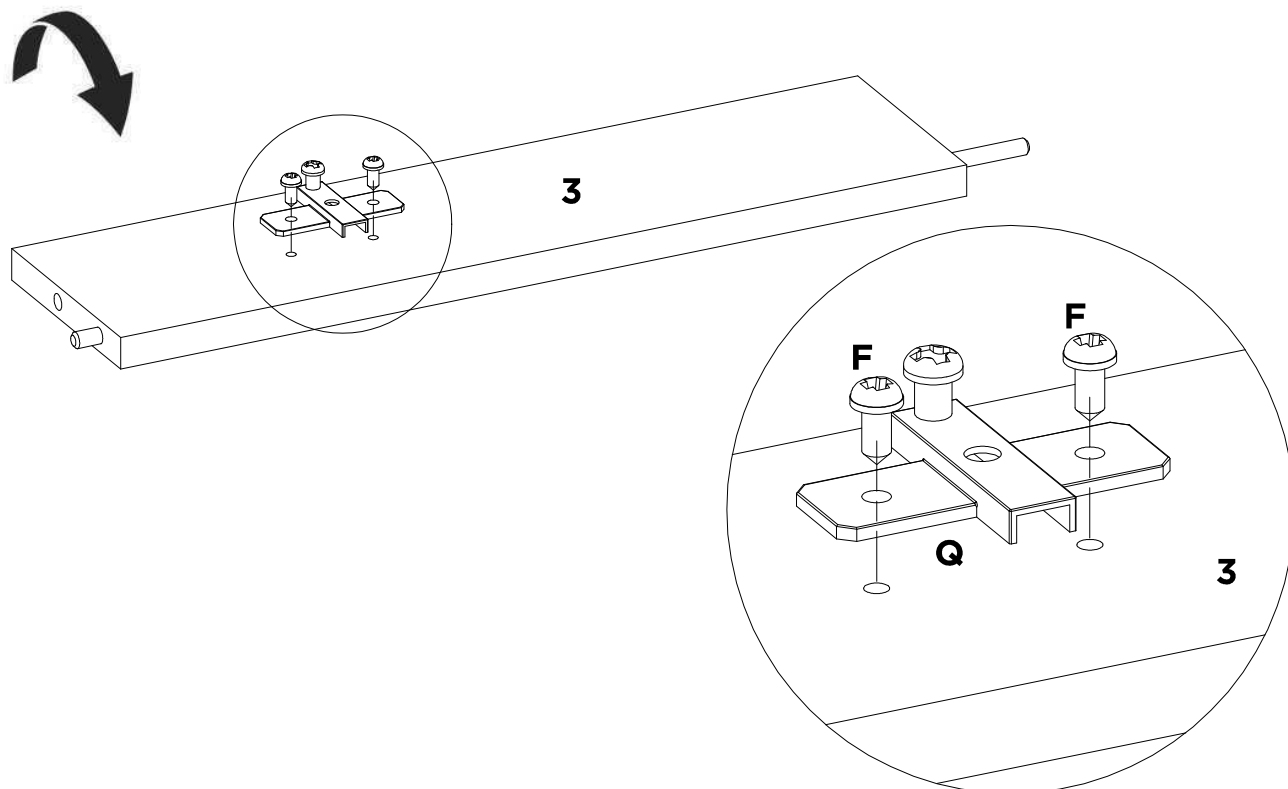

<b>F</b>	<b>Q</b>	-	-	-	-	-	-
<b>X2</b>	<b>X1</b>	-	-	-	-	-	-

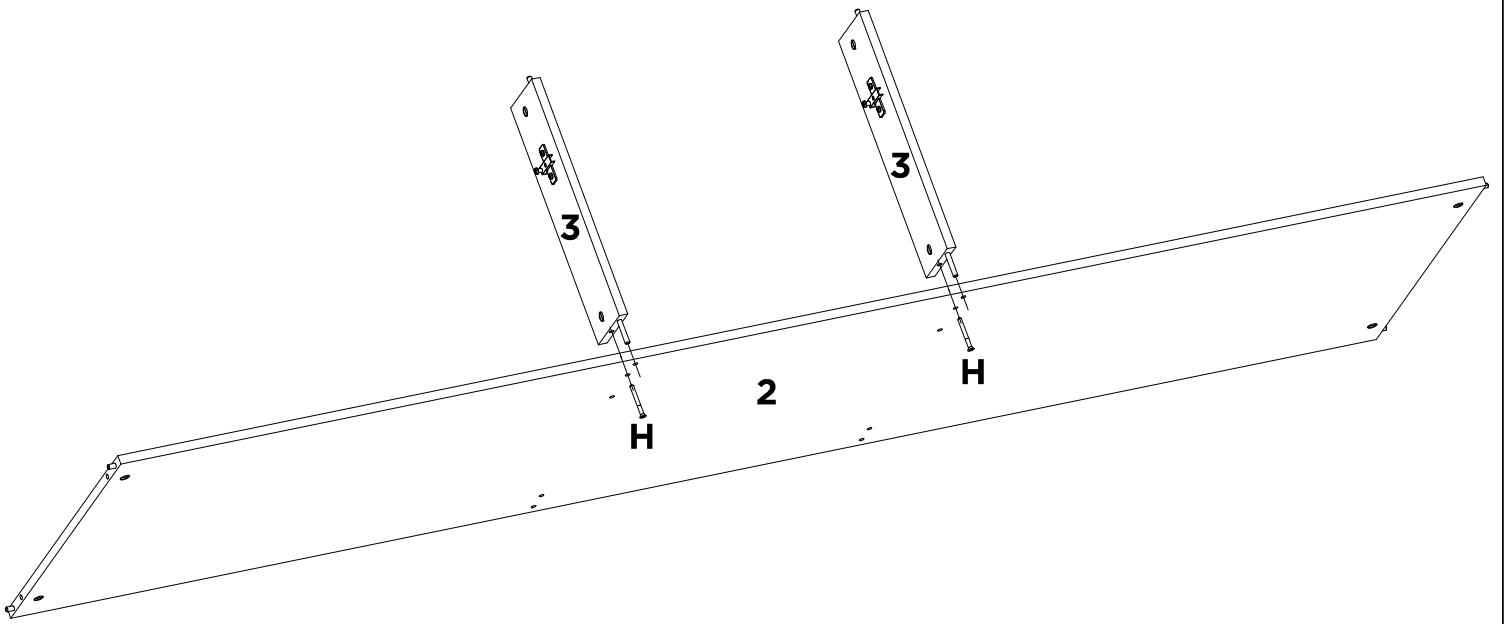

H	-	-	-	-	-	-	-
X2	-	-	-	-	-	-	-

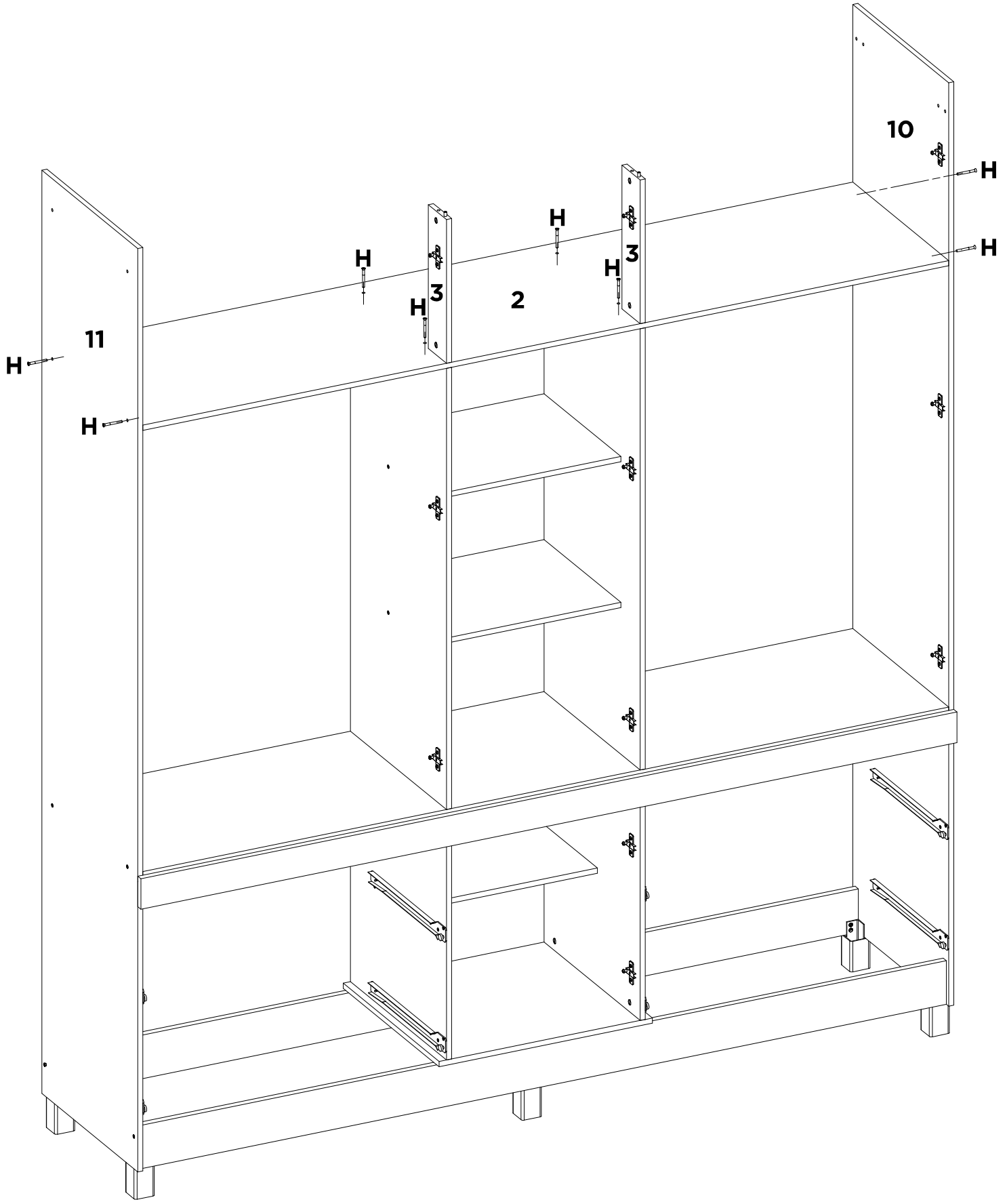

H	-	-	-	-	-	-	-	-
X8	-	-	-	-	-	-	-	-

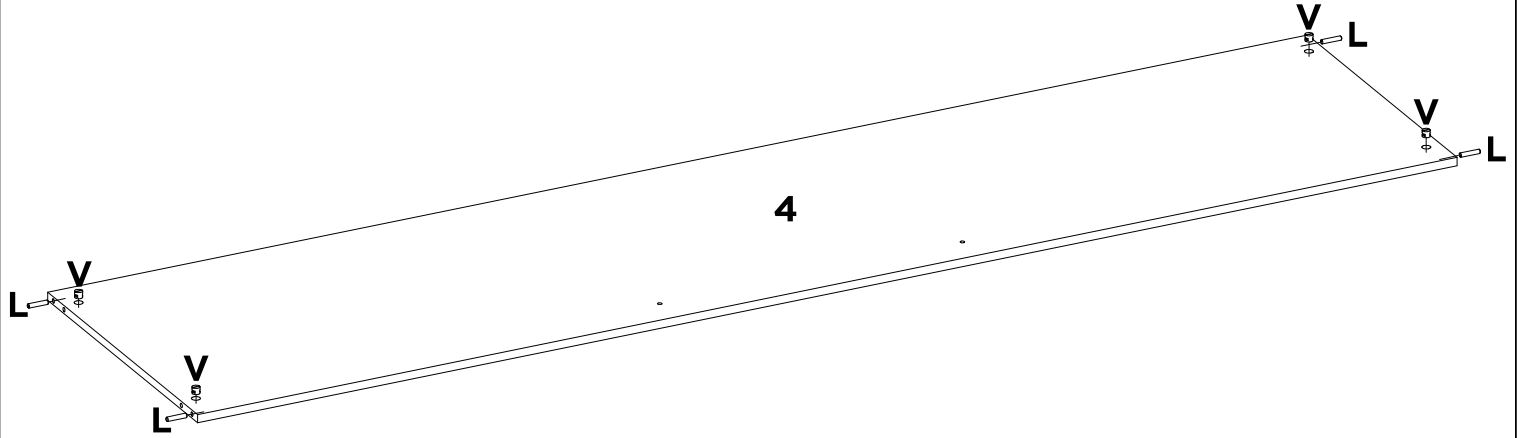

L	V	-	-	-	-	-	-
X4	X4	-	-	-	-	-	-

# 27

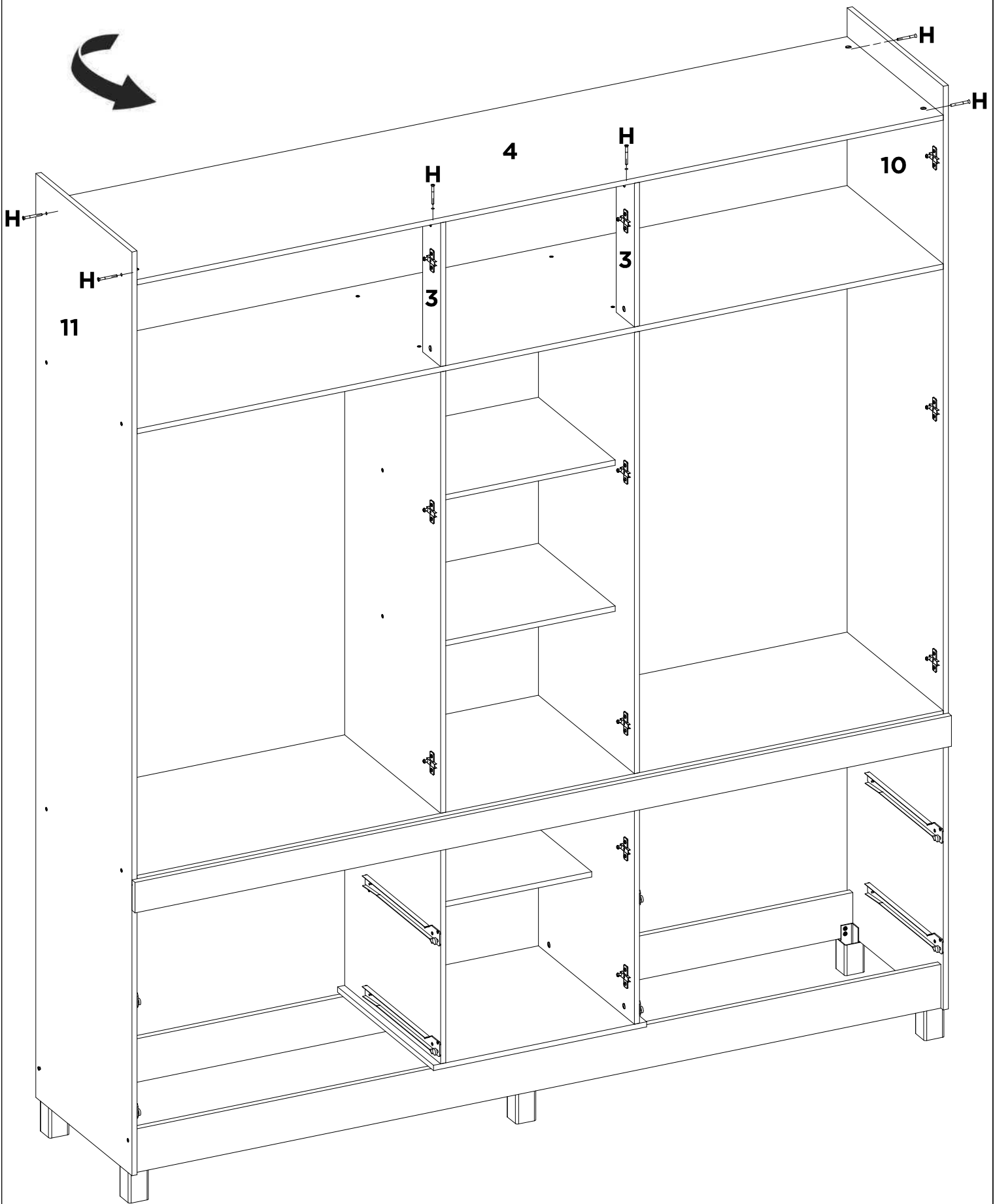

<b>H</b>	-	-	-	-	-	-	-	-
<b>X6</b>	-	-	-	-	-	-	-	-

# 28

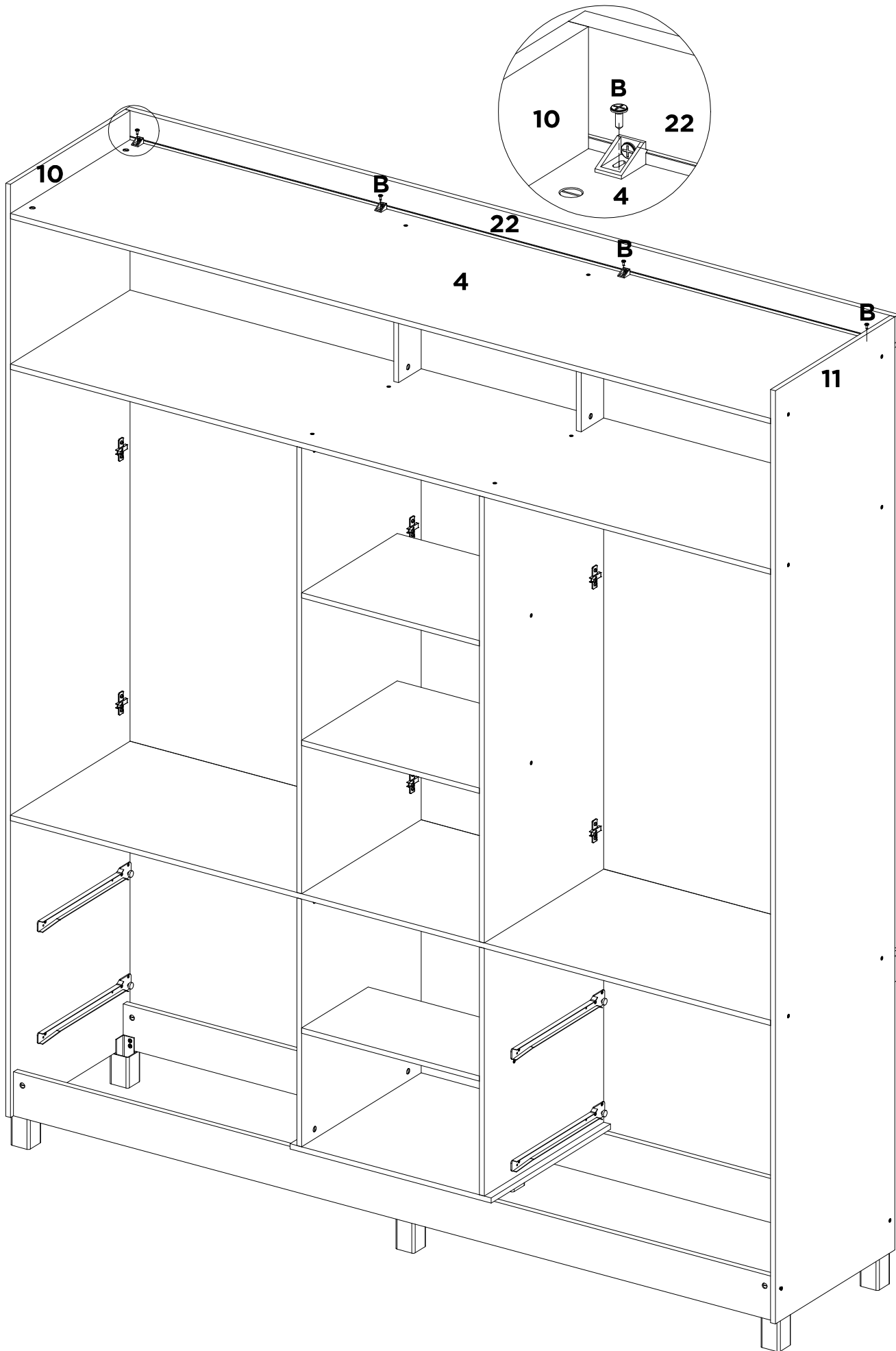

<b>B</b>	-	-	-	-	-	-	-	-
<b>X4</b>	-	-	-	-	-	-	-	-

# 29

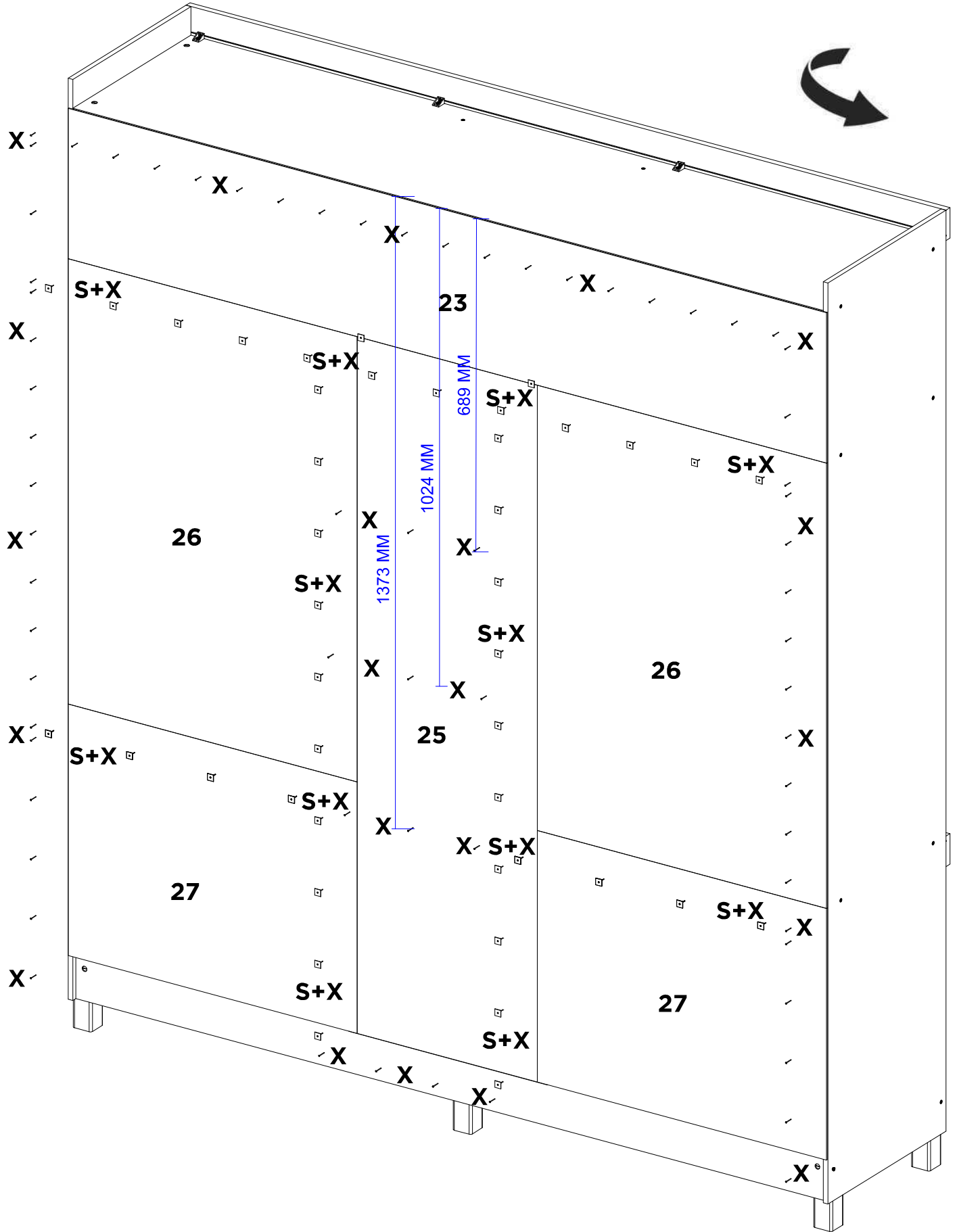

S	X	-	-	-	-	-	-
X50	X120	-	-	-	-	-	-



# 30

# 4x

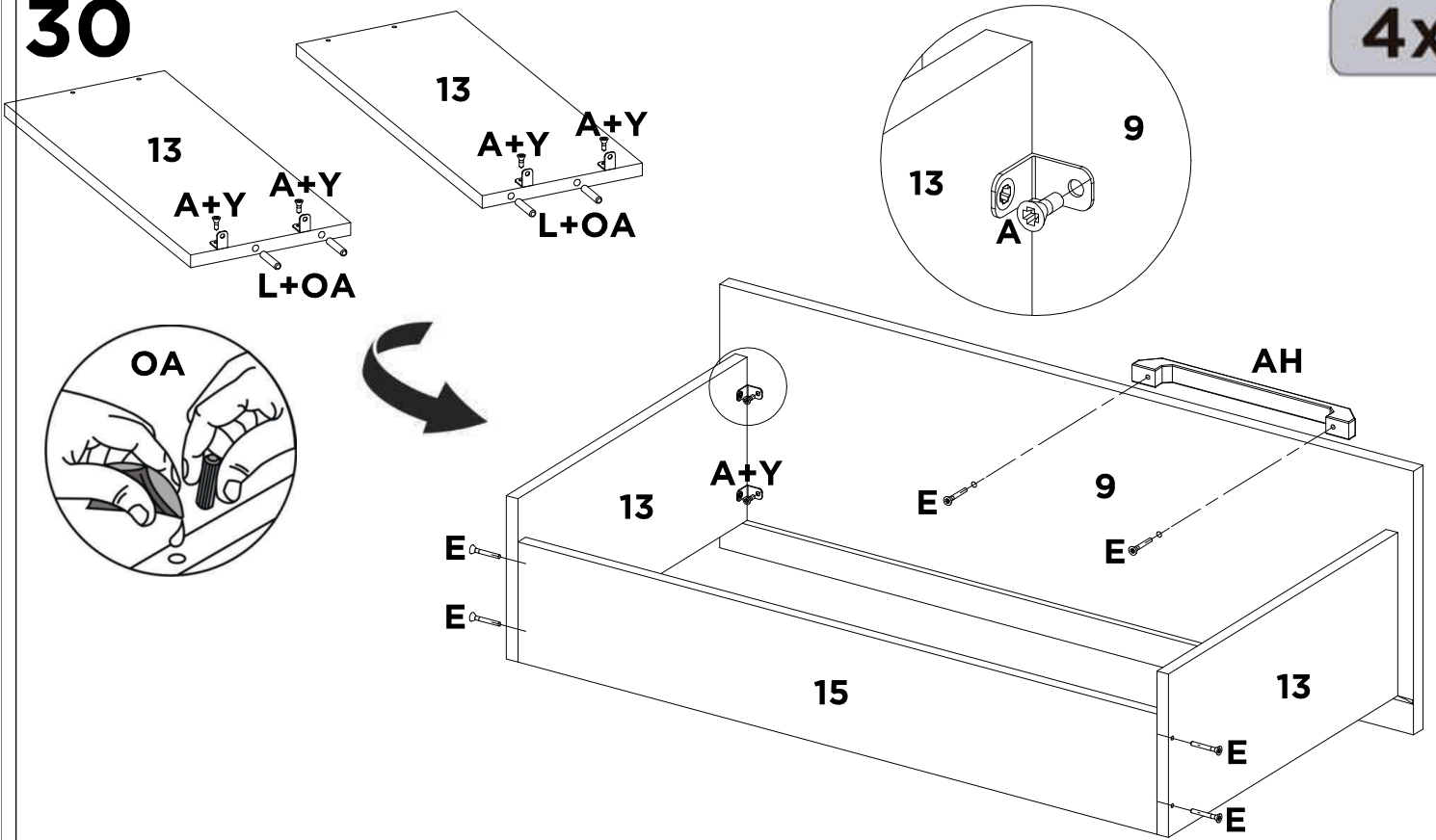

<b>A</b>	<b>AH</b>	<b>E</b>	<b>L</b>	<b>OA</b>	<b>Y</b>	-	-
<b>X32</b>	<b>X4</b>	<b>X24</b>	<b>X16</b>	<b>X2</b>	<b>X16</b>	-	-

# 30A

# 4x

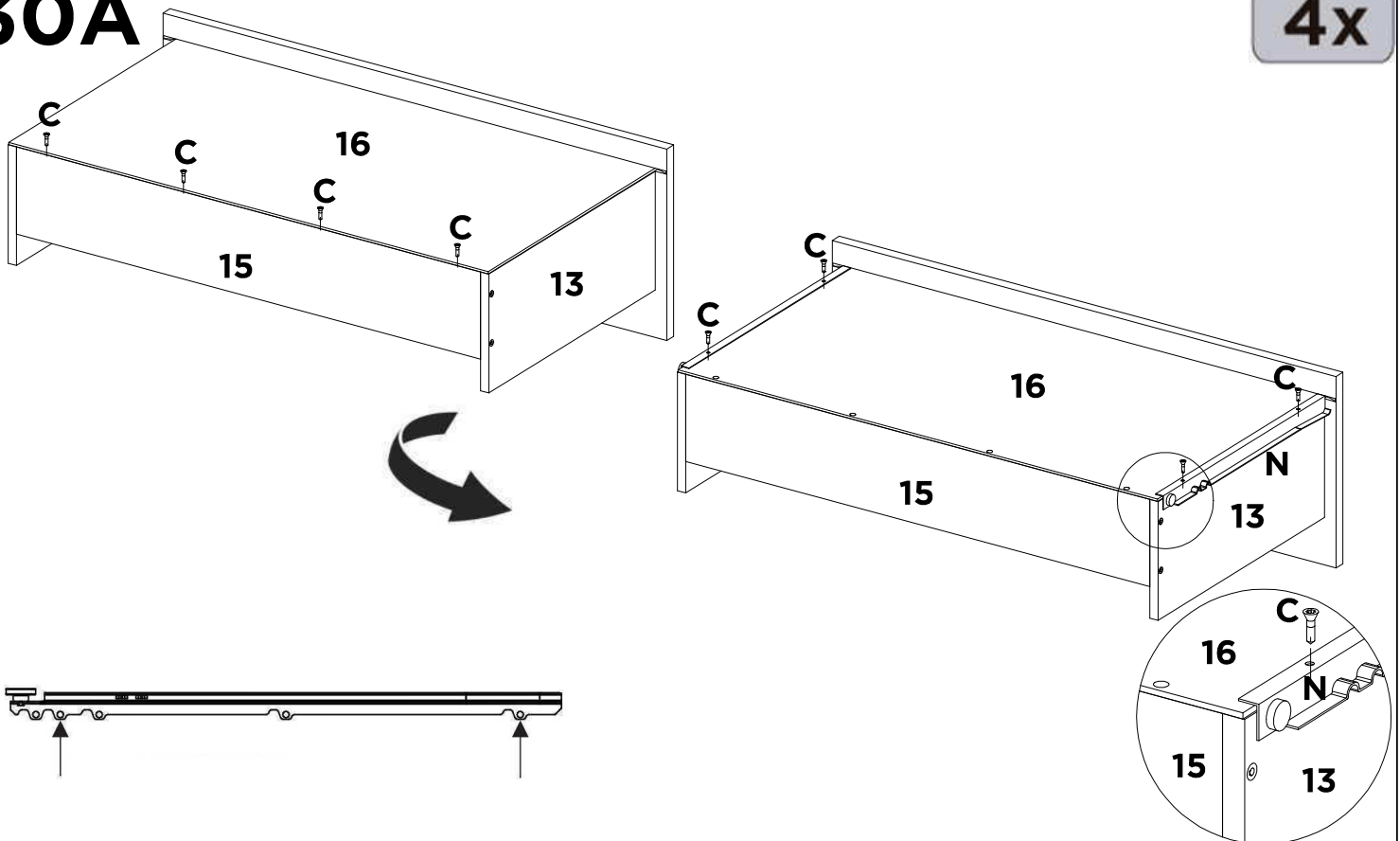

<b>C</b>	<b>N</b>	-	-	-	-	-	-
<b>X32</b>	<b>X8</b>	-	-	-	-	-	-

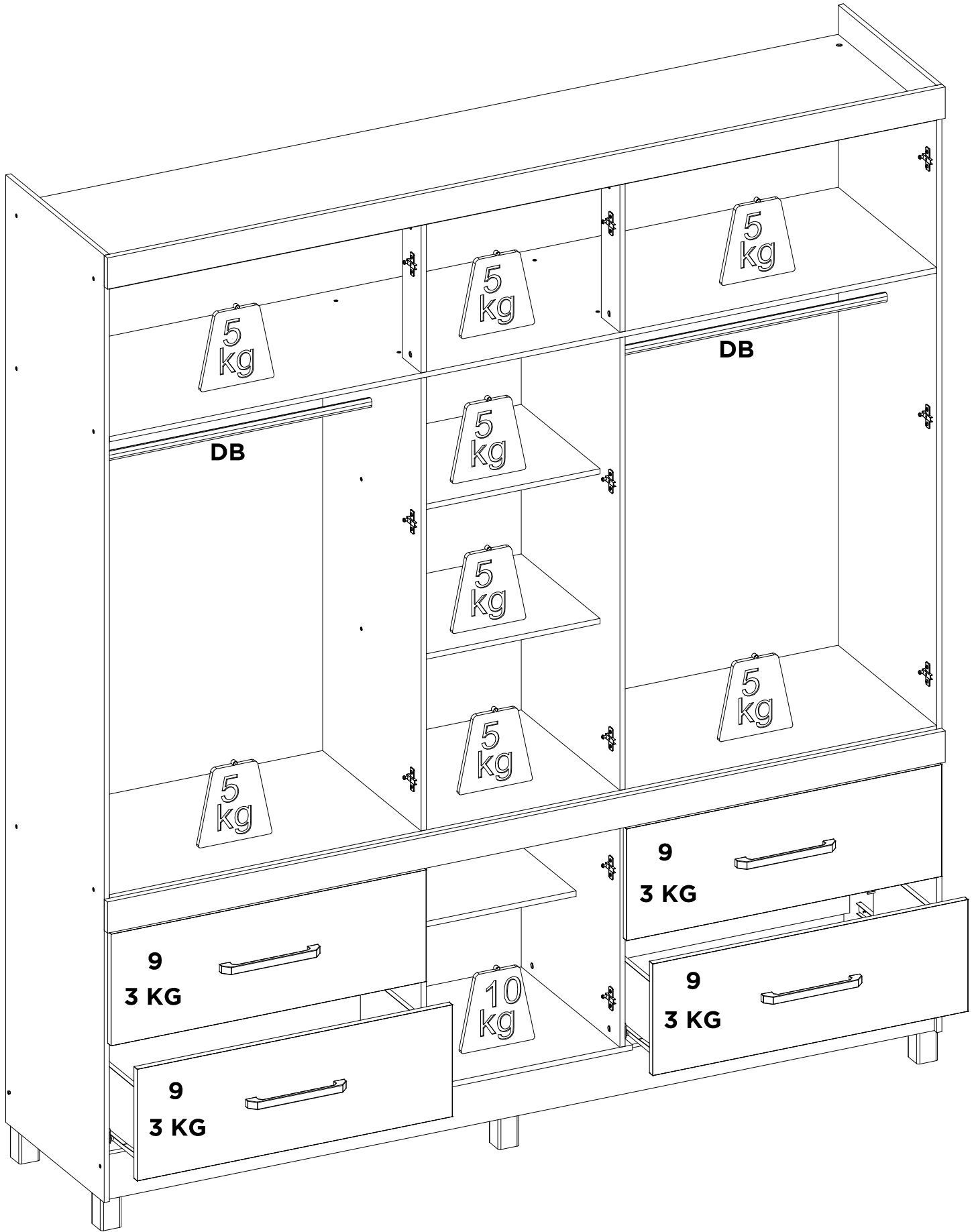

DB	-	-	-	-	-	-	-
X2	-	-	-	-	-	-	-

# 32

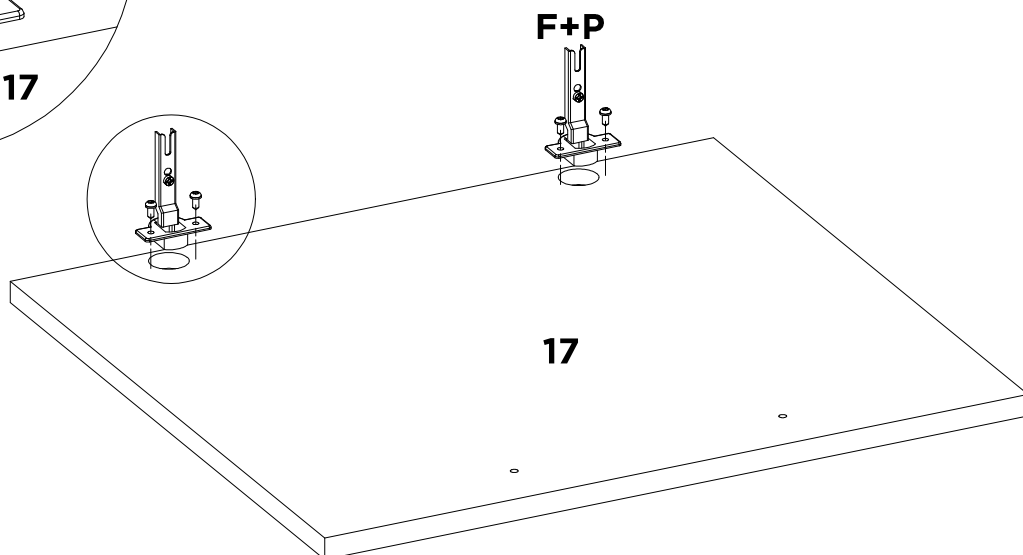
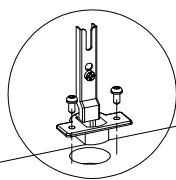
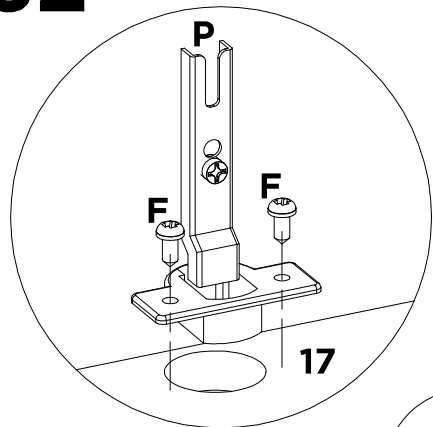

<b>F</b>	<b>P</b>	-	-	-	-	-	-
<b>X4</b>	<b>X2</b>	-	-	-	-	-	-

# 32A

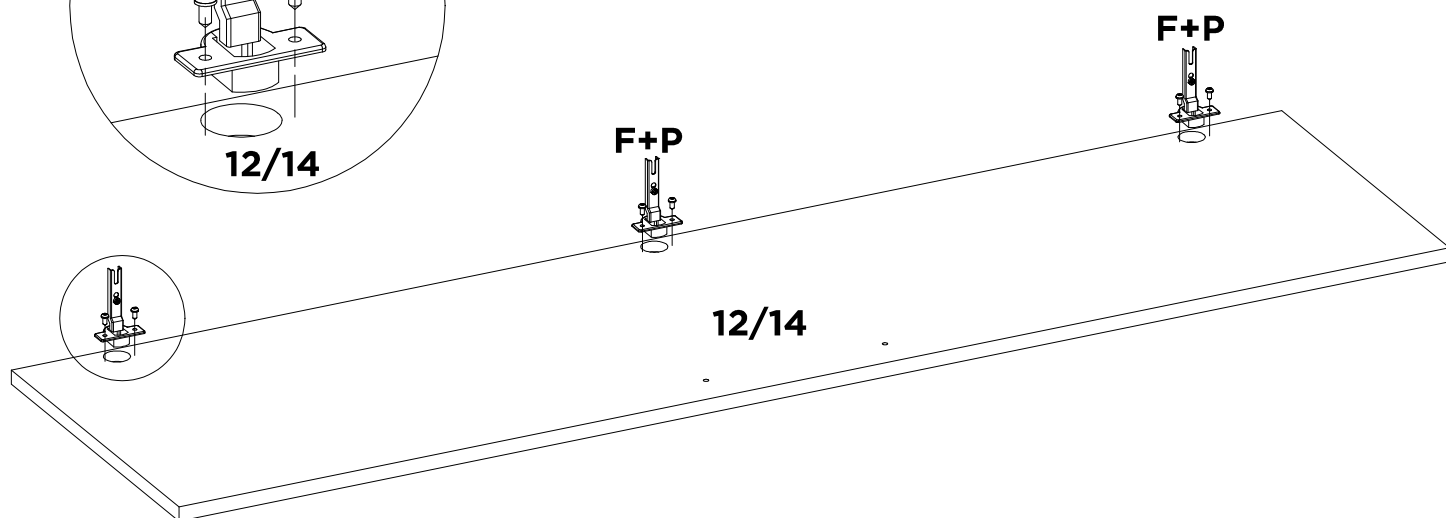
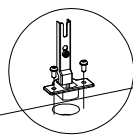
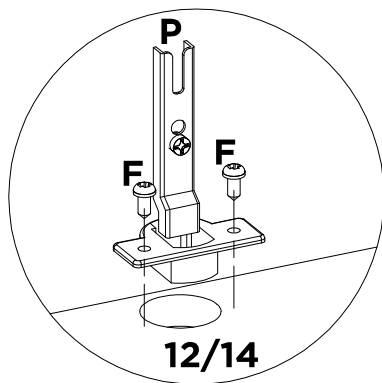
**5x**

<b>F</b>	<b>P</b>	-	-	-	-	-	-
<b>X30</b>	<b>X15</b>	-	-	-	-	-	-

# 33

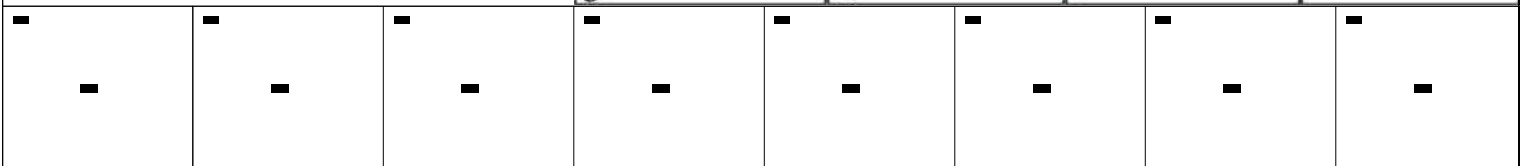
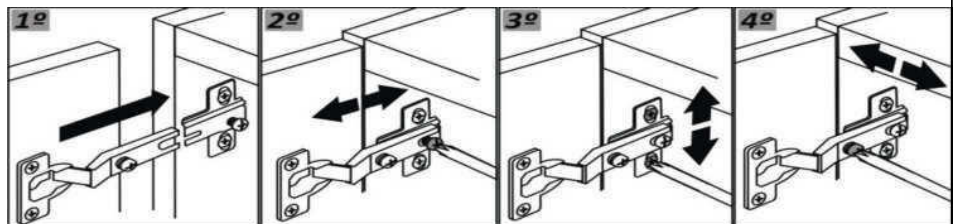
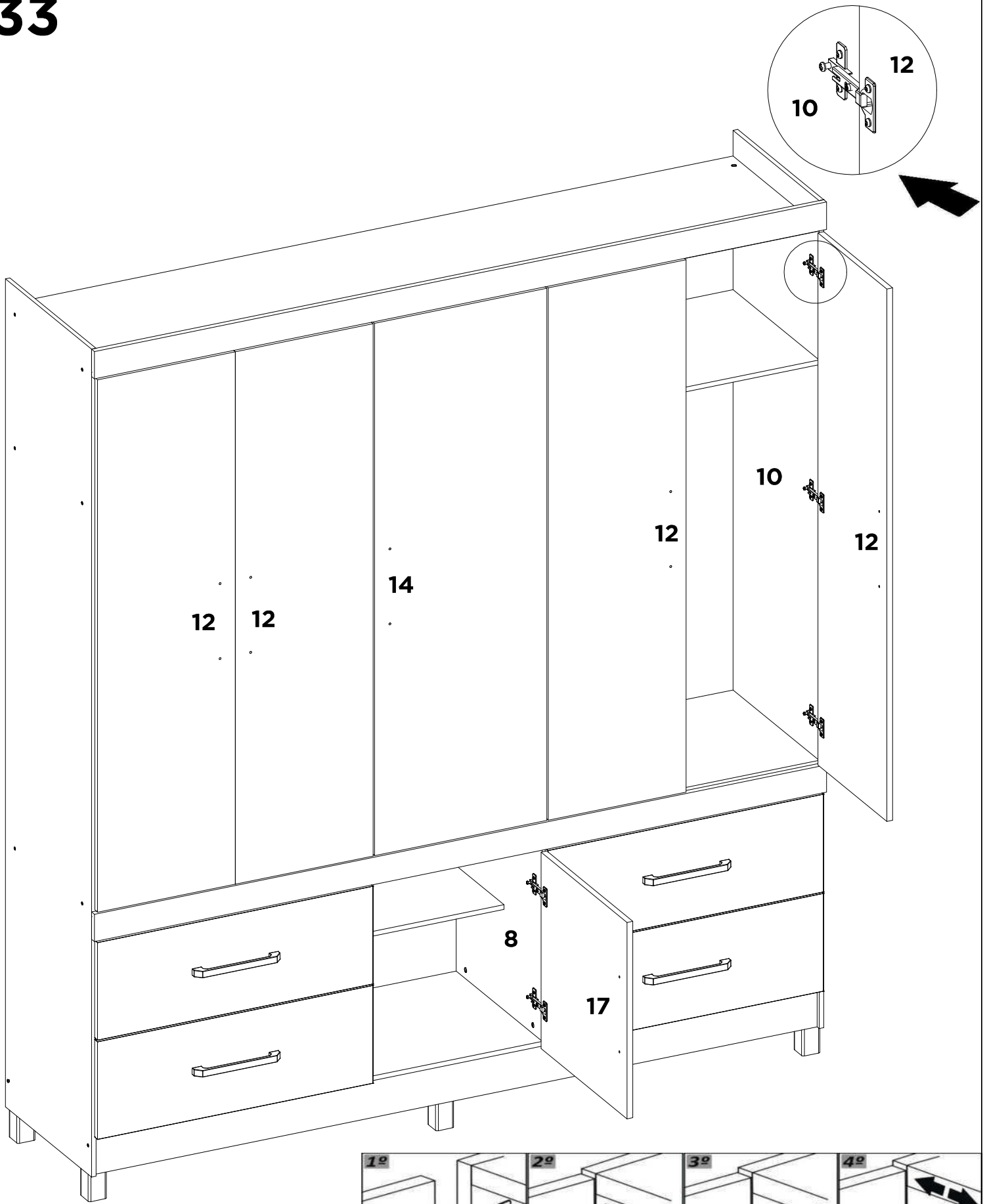

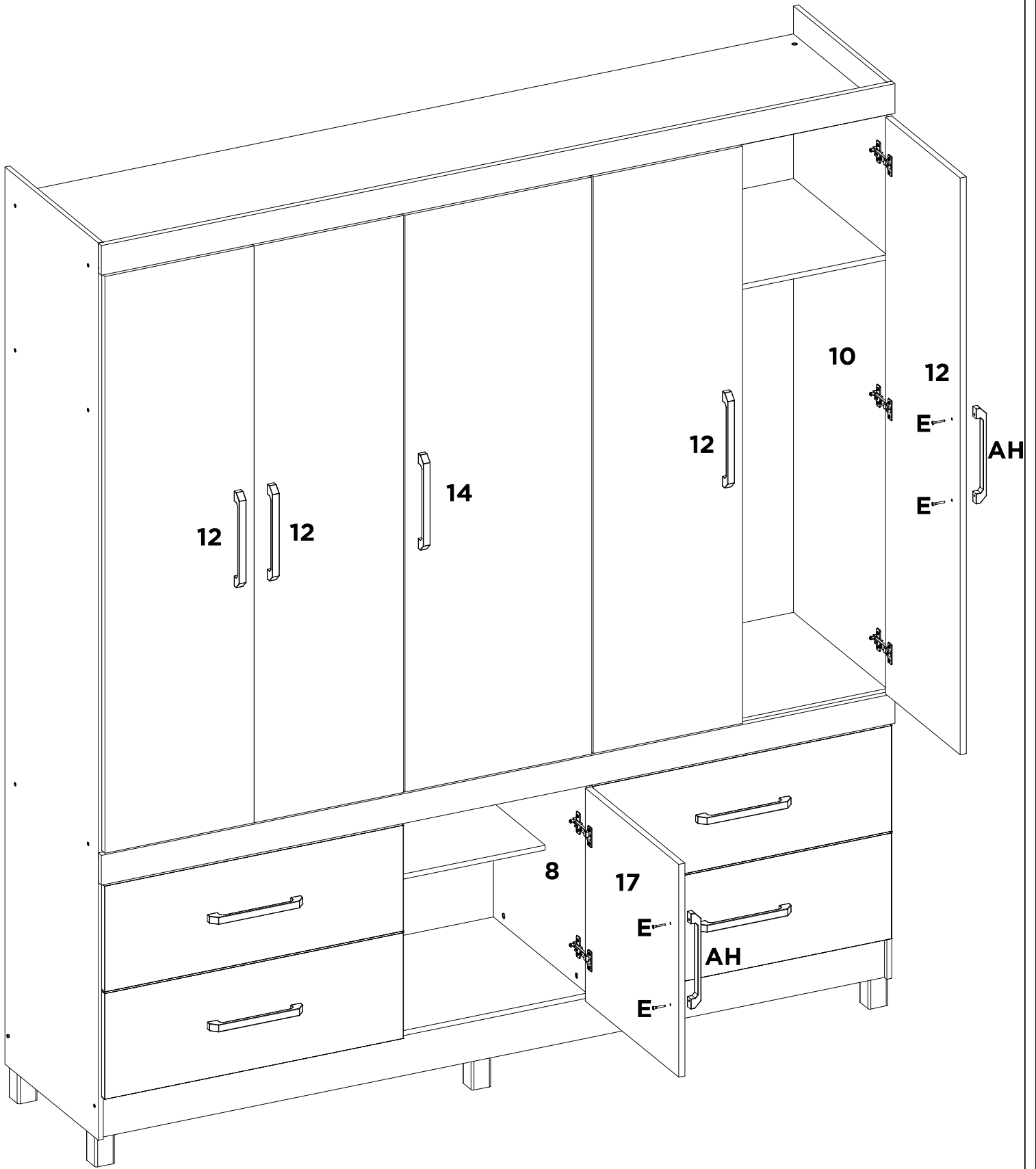

AH	E	-	-	-	-	-	-
X6	X12	-	-	-	-	-	-

# 35

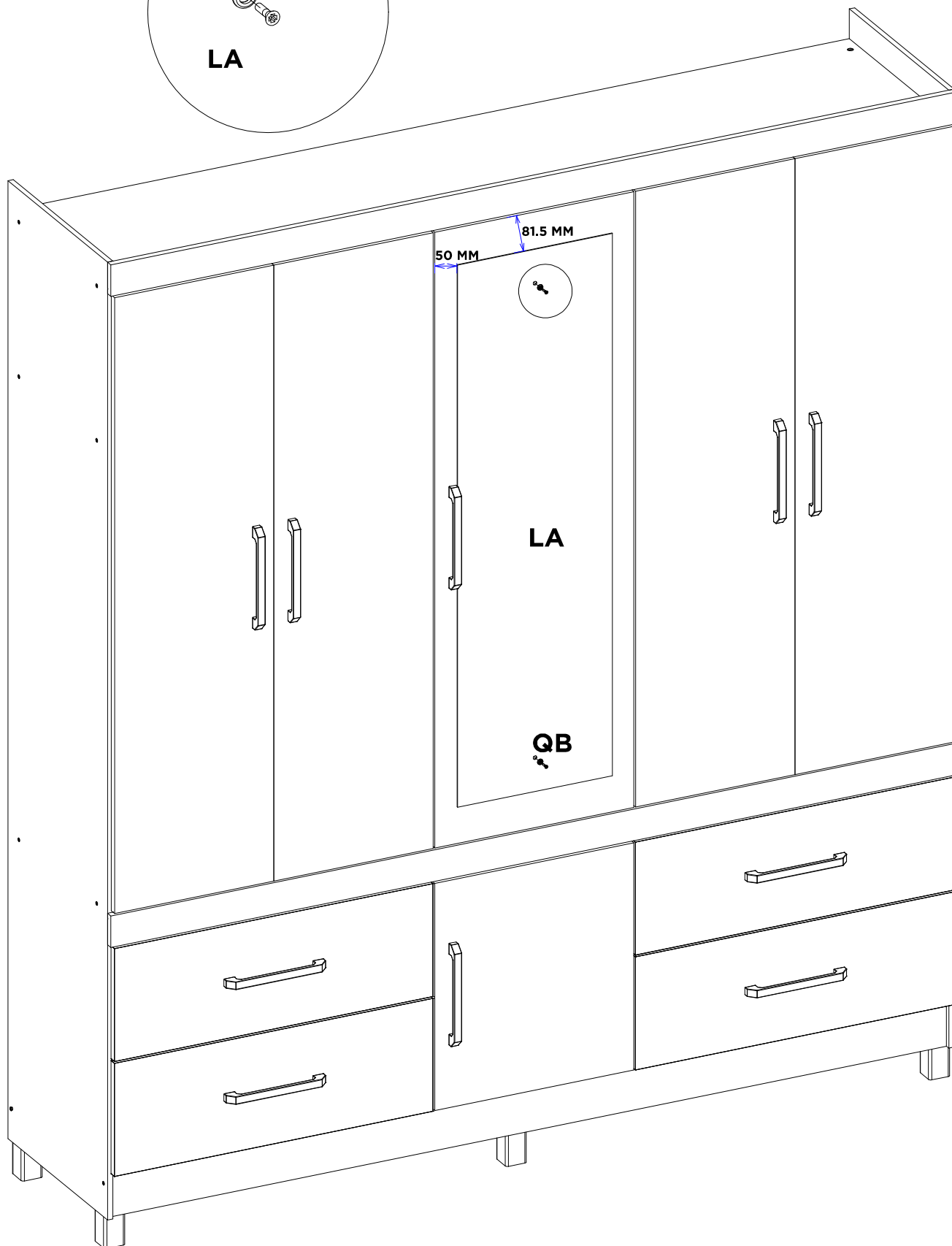
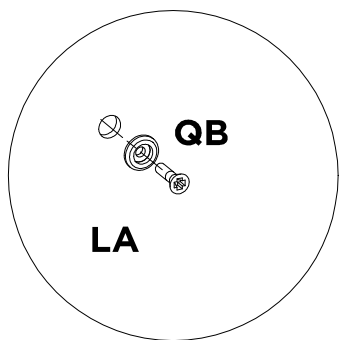

LA	QB	-	-	-	-	-	-
X1	X2	-	-	-	-	-	-

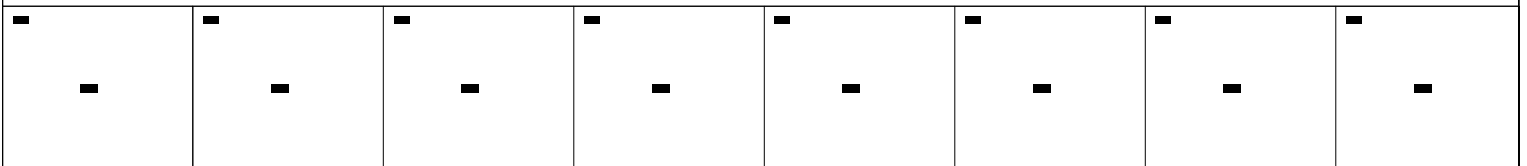
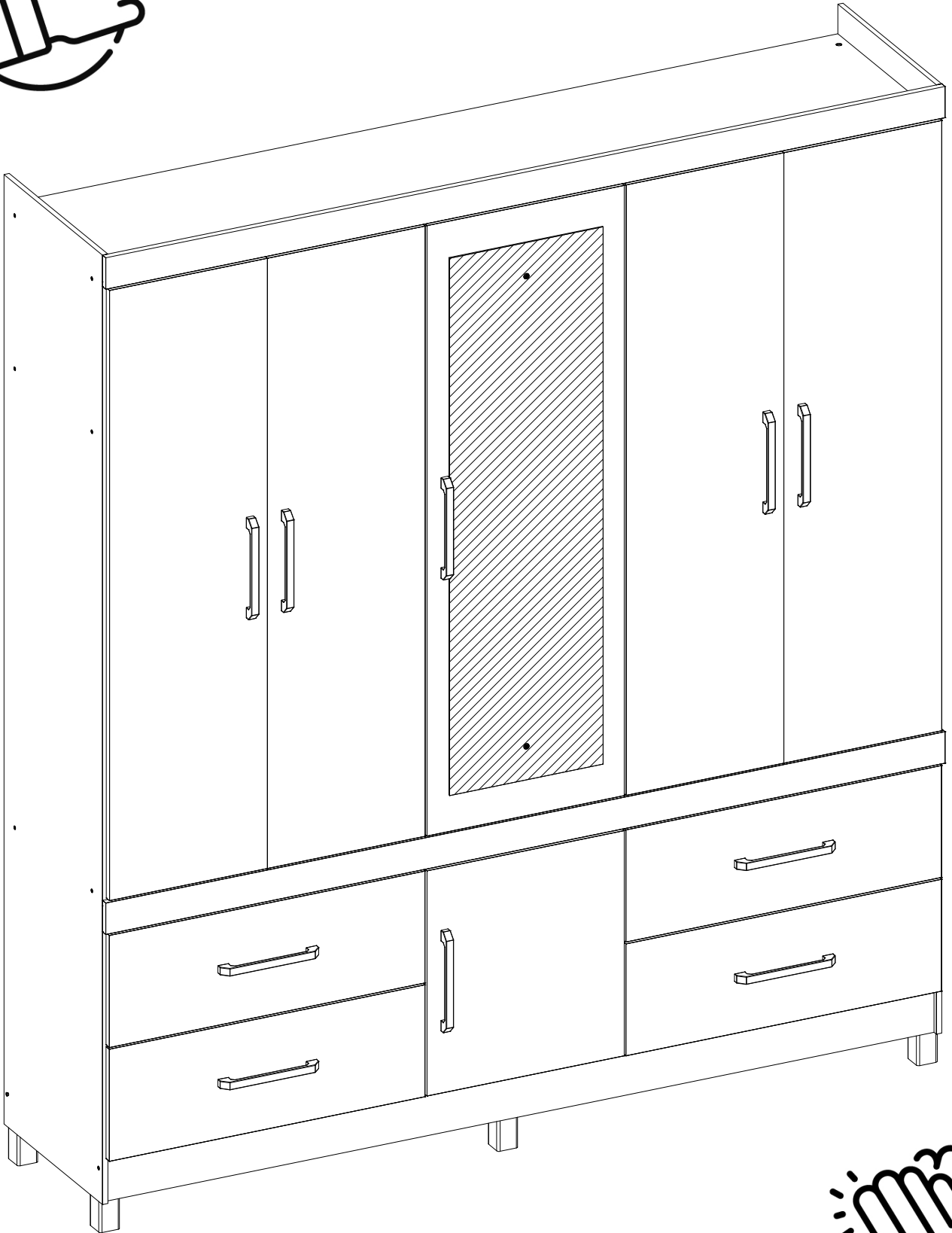



DemóBILE