

Item	Caixa Caja Box	Qtd Ctd Qty	Descrição Descripción Description	Medidas (mm) Dimensions (mm) Size (measurements) (mm)
01	2/3	01	Rodapé Frontal Rodapié Frontal Front baseboard	1555x73x15
02	2/3	01	Travessa do rodapé Carril pie Baseboard crosspiece	409x73x15
03	2/3	01	Rodapé Traseiro Rodapié trasero Rear baseboard	1555x73x15
04	2/3	01	Travessa Base Frontal Travesa Base Frontal Front Base Tray	1555x80x15
05	2/3	01	Travessa Base traseira Travesaño trasero Rear base carrier	1555x80x15
06	1/3	01	Divisão das gavetas División de los cajones Division of drawers	445x434x15
07	2/3	01	Tampo das Gavetas Superfície de cajones Surface of drawers	1555x445x15
08	1/3	01	Lateral esquerda Lateral izquierda Left side	2200x445x15
09	2/3	01	Divisão División Division	1151x445x15
10=14	1/3	01	Prateleira Estante Shelf	770x400x15
11	1/3	01	Ripa do Maleiro Listón del Armario de Equipaje Clapboard luggage locker	414x73x15
12	2/3	01	Chão do Maleiro Piso del Armario de Equipaje Floor of the Maleiro	1555x445x15
13	1/3	01	Lateral direita Lateral derecha Right side	2200x445x15
14=10	1/3	02	Prateleira Estante Shelf	770x400x15
15	2/3	01	Tampo Tapa Top	1555x445x15
16	1/3	01	Chapéu Sombrero Hat	1583x73x15
17	2/3	01	Fundo Superior Fondo Superior Superior background	1579x436x3
18	3/3	02	Fundo Fondo Bottom	1622x789x3
19	3/3	04	Porta Puerta Door	1590x388x15
20	1/3	04	Frente de gaveta Frente de cajón Front of drawer	780x220x15
21	1/3 e 2/3	08	Lado de gaveta Lado del cajón Side of drawer	400x122x15
22	3/3	04	Fundo de gaveta Fondo del cajón Drawer bottom	726x411x3
23	1/3	04	Ripa de trás Malla detrás Rear lath	745x122x15

Ferragens | Herrajes | Hardware

A 08x Parafuso 4,5x50mm CHT. Tornillo 4,5x50mm CHT. Screw 4,5x50mm CHT.	B 06x Parafuso 4,0x25mm FLA. Tornillo 4,0x25mm FLA. Screw 4,0x25mm FLA.	C 30x Parafuso 3,5x40mm CHT. Tornillo 3,5x40mm CHT. Screw 3,5x40mm CHT.	D 12x Parafuso 3,5x25mm FLA. Tornillo 3,5x25mm FLA. Screw 3,5x25mm FLA.	E 48x Parafuso 3,5x14mm FLA. Tornillo 3,5x14mm FLA. Screw 3,5x14mm FLA.
F 68x Parafuso 3,5x12mm CHT. Tornillo 3,5x12mm CHT. Screw 3,5x12mm CHT.	G 08x Parafuso 3,0x30mm CHT. Tornillo 3,0x30mm CHT. Screw 3,0x30mm CHT.	H 08x Parafuso 3,0x16mm CHT. Tornillo 3,0x16mm CHT. Screw 3,0x16mm CHT.	I 08x Prego 12x12mm Anelado Clavo 12x12mm Anillado Ringed Nails 12x12mm	J 134x Prego 10x10mm Clavo 10x10mm Nail 10x10mm
K 30x Fixador de fundos Fijador de fondos Bottom fixer	L 80x Cavilha 8x25mm Cinta 8x25mm Dowel 8x25mm	M 14x Cantoneira plástica Cantонера plástica Plastic angle brackets	N 08x Cantoneira suporte triangular Cantонера soporte triangular Triangle support angle	O 06x Porca Sextavada Tuerca Hexagonal Hexagon Nut
P 08x Porca cilíndrica Tuerca cilíndrica Cylindrical nut	Q 12x Calço metal 5mm Calzado metálico 5mm 5 mm metal shim	R 12x Dobradiça metal 26mm Bisagra de metal 26mm 26 mm metal hinge	S 04x Corrediça telescópica Corredera telescópica Telescopic slide	T 02x Suporte cabideiro Soporte de percha Coat hanger support
U 01x Cabideiro Alum. 762mm Alu 762mm percha Alu coat hanger 762mm	V 12x Puxador Vilage pequeno Tirador Vilage pequeno Small Vilage Handle	W 08x Sapata "L" 16x20mm Zapata "L" 16x20mm "L" shoe 16x20mm	X 02x Sachê de cola Bolsa de pegamento Glue bag	Y 29x Adesivo tapa parafuso 10mm Adhesivo tapón de tornillo 10mm Bolt cover adhesive 10mm
Z 02x Giz de correção Tiza de corrección Chalk of correction	AA 01x Etiqueta resinada Henn Etiqueta resinada Henn Henn resin label			

HENN

Ind. e Com. de Móveis Henn
Mondai - SC - Brasil

+55 49 3674.3500

@moveishenn
www.henn.com.br

INSTRUÇÕES DE MONTAGEM

INSTRUCCIONES DE MONTAJE
ASSEMBLY INSTRUCTIONS

Roupeiro Americano 04 Portas | Armario Americano 04 Puertas |
Wardrobe Americano 04 Doors

I113-05 Branco HP

I113-23 Duna

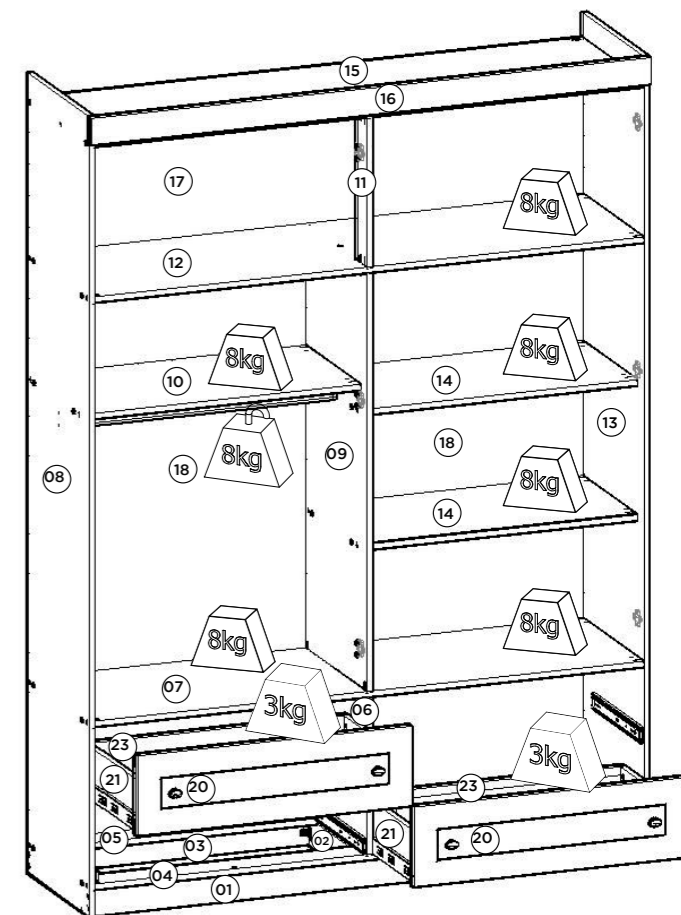
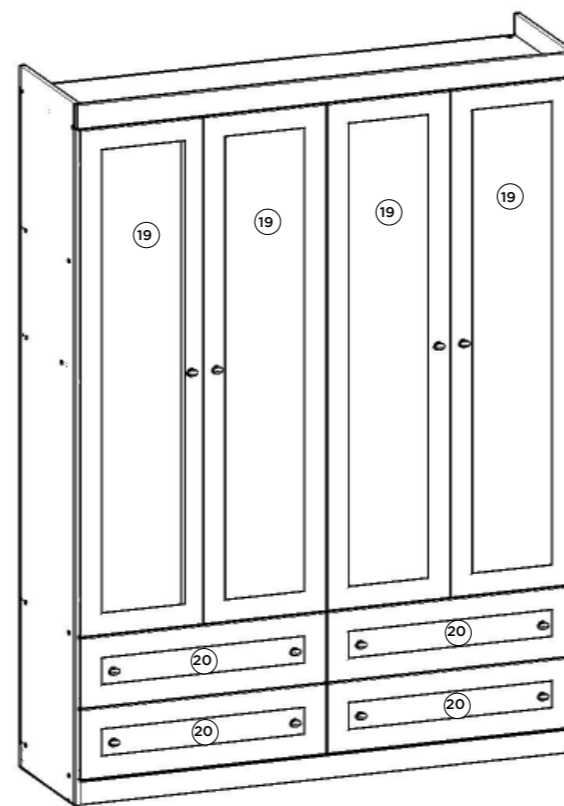

Pesos máximos recomendados com carga distribuída.
Peso máximo recomendado con la carga distribuida.
Recommended maximum weights with evenly distributed.

Requisitos para montagem
Requisitor para la montaje
Assembly Requirements

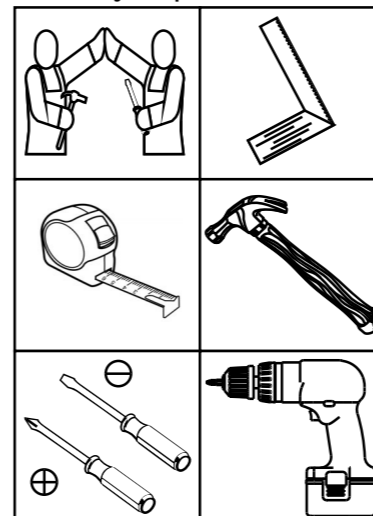

Imagens meramente ilustrativas
Imágenes meramente ilustrativas
Images for illustration only

AVISO

Para limpeza de seu móvel, use uma flanela seca ou umedecida, e não utilize produtos químicos que possam danificar seu produto.

SISTEMA DE MONTAGEM

O sistema de montagem dos produtos, funciona de acordo com a ordem crescente dos números indicados no desenho. Ex: 01, 02, 03, 04... até a conclusão da montagem.

ASSISTÊNCIA TÉCNICA

Para solicitação de Assistência Técnica você consumidor deverá entrar em contato com o Lojista o qual você realizou a compra deste produto e solicitar a assistência técnica das peças avariadas. A garantia abrange todas as peças, partes e componentes que eventualmente venham apresentar defeito de fabricação no prazo de 03 (três) meses, contando a partir da entrega do produto ao consumidor, mediante nota fiscal de compra. Se houver qualquer alteração na estrutura do produto ou ocorrer defeito por negligência do montador/consumidor em relação a instrução de montagem e manuseio, não será fornecido assistência técnica gratuita.

ADVERTENCIA

Para limpieza de su móbil, use una flanela seca o húmeda, y no utilice productos químicos que puedan dañar su producto.

SISTEMA DE MONTAJE

El sistema de montaje de los productos funciona de acuerdo con el orden creciente de los números indicados en el dibujo. Ej.: 01, 02, 03, 04... hasta la conclusión del montaje.

ASISTENCIA TÉCNICA

Para solicitar Asistencia Técnica, el consumidor debe comunicarse con el Comercio que usted realizó la compra de este producto y solicita asistencia técnica para las partes dañadas. La garantía cubre todas las partes, piezas y componentes que eventualmente puedan presentar defecto de fabricación en el plazo de 03 (tres) meses, contados a partir de la entrega del producto al consumidor, mediante factura de compra. Si se produce algún cambio en la estructura del producto o se produce un defecto por negligencia del montador/consumidor en relación con las instrucciones de montaje y manipulación, no se prestará asistencia técnica gratuita.

NOTICE

To clean your furniture, use a dry or wet cloth, and do not use chemicals that may damage your product.

ASSEMBLY SYSTEM

The products' assembly system works according to the increasing order of the indicated numbers. For example: 01, 02, 03, 04 ... to the end of the assembly.

TECHNICAL ASSISTANCE

To request Technical Assistance, the consumer must contact the retailer from whom you purchased this product and request technical assistance for the damaged parts. The warranty covers all parts, parts and components that may eventually present a manufacturing defect within a period of 03 (three) months, counting from the delivery of the product to the consumer, by means of a purchase invoice. If there is any change in the structure of the product or defect occurs due to negligence of the assembler/consumer in relation to the assembly and handling instruction, free technical assistance will not be provided.

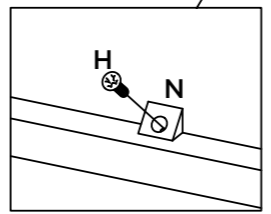
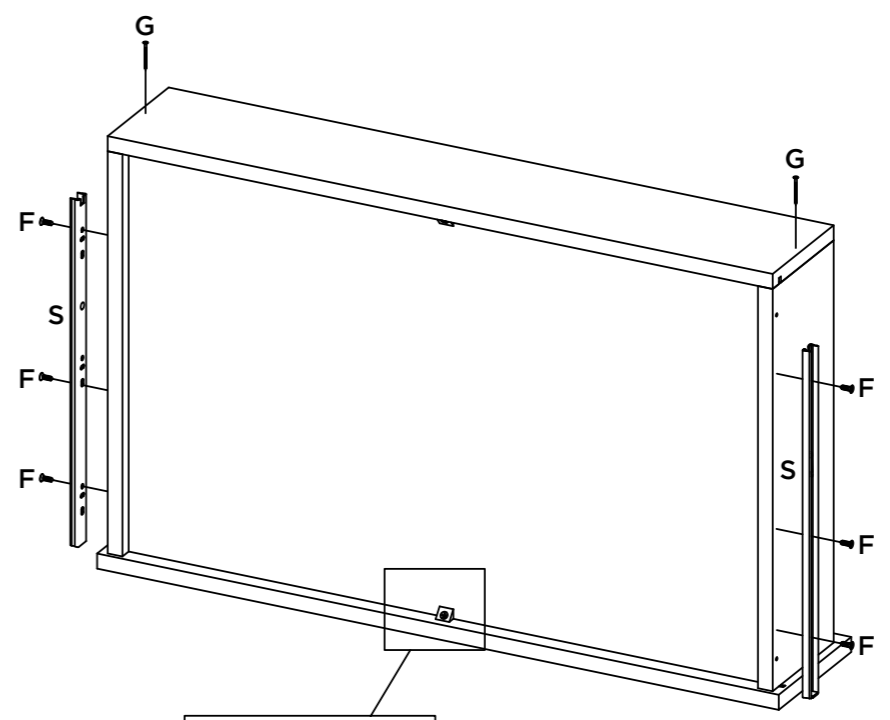
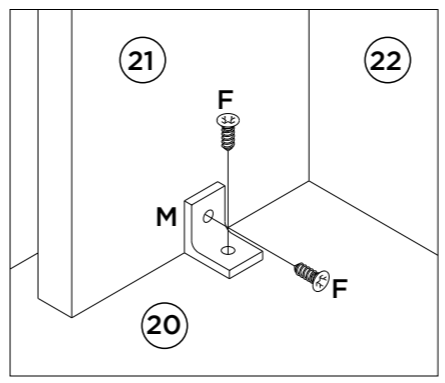
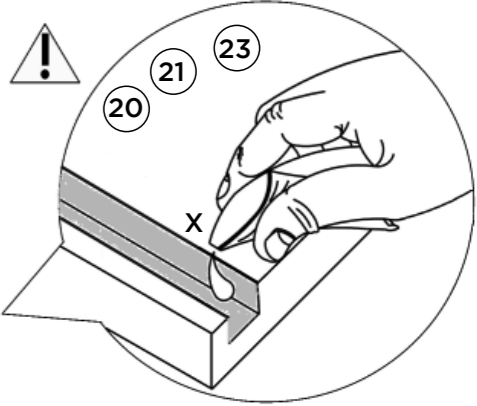
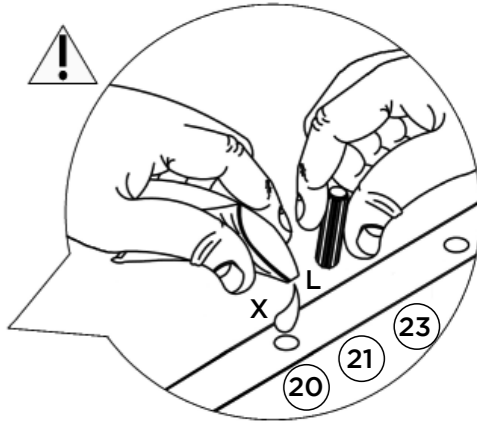
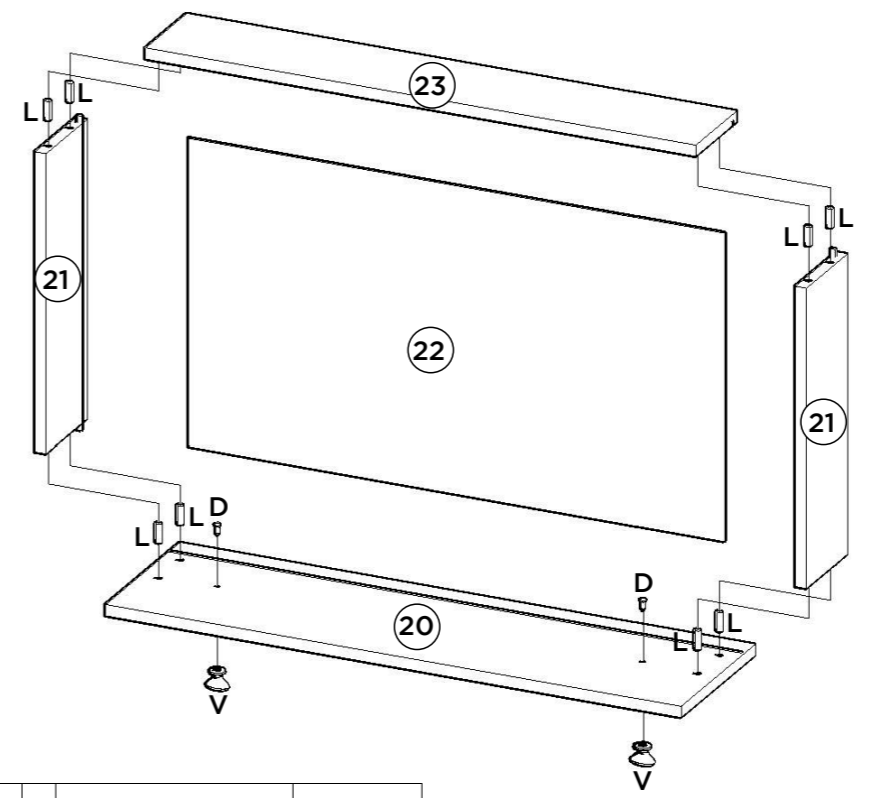
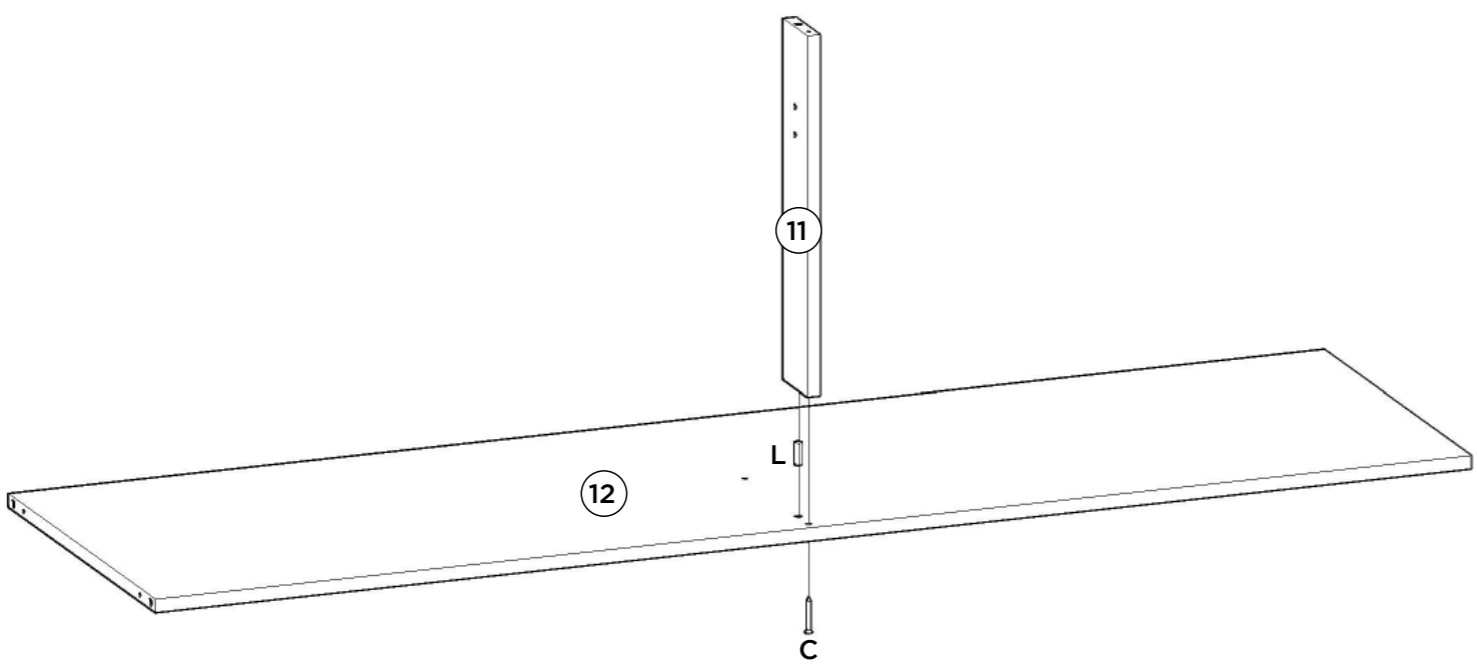
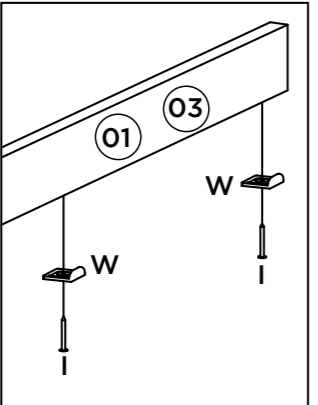
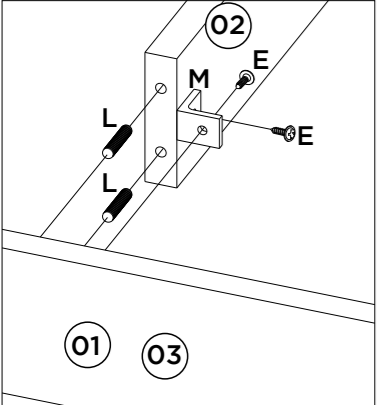
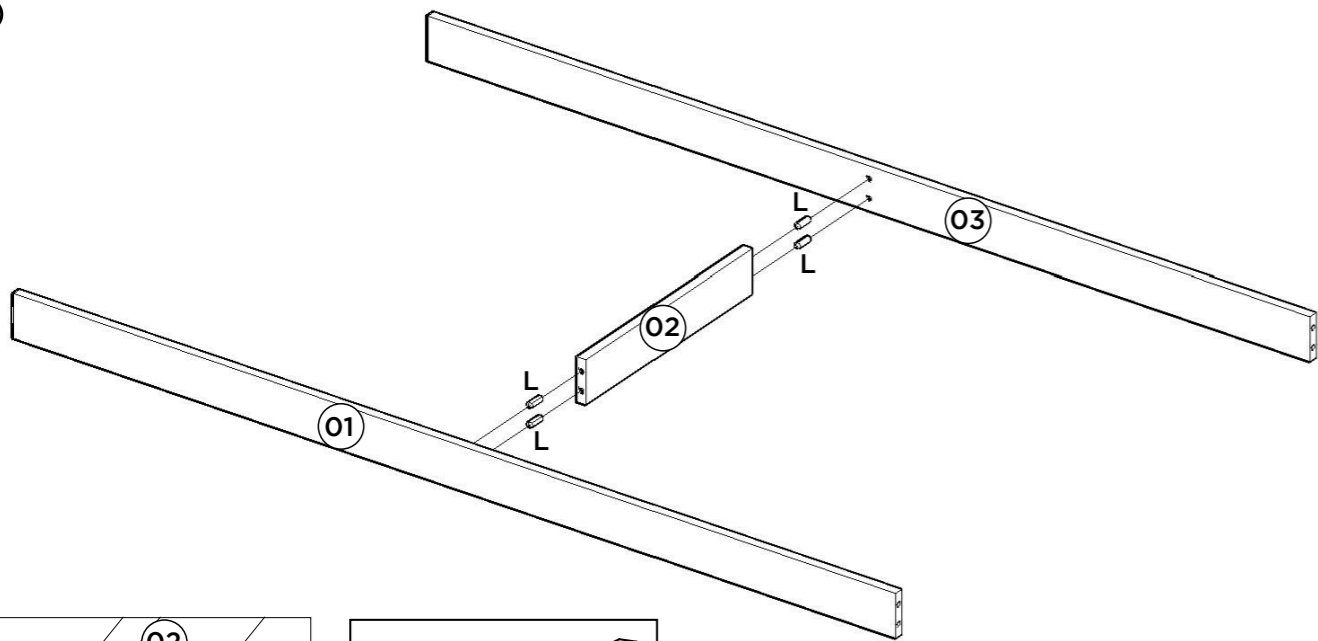

A correia (S) deverá ser alinhada com a parte de baixo do lado de gaveta (21).

la diapositiva (S) debe estar alineado con la parte inferior del cajón (21).

The slide (S) should be aligned with the underside of the drawer side (21).

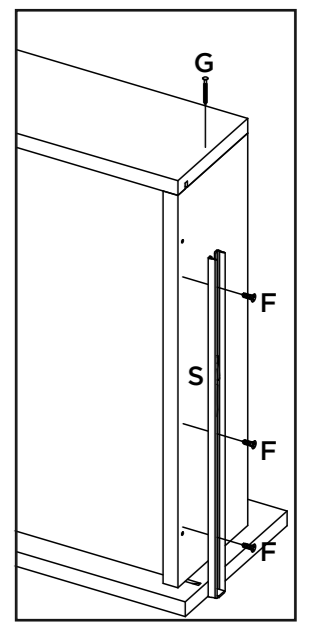



Vídeo: Instalar e regular Dobradiças

Video: Instale y ajuste las bisagras

Video: Install and adjust hinges

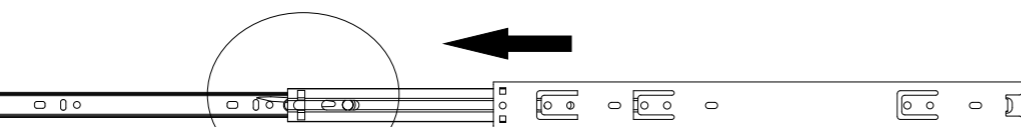
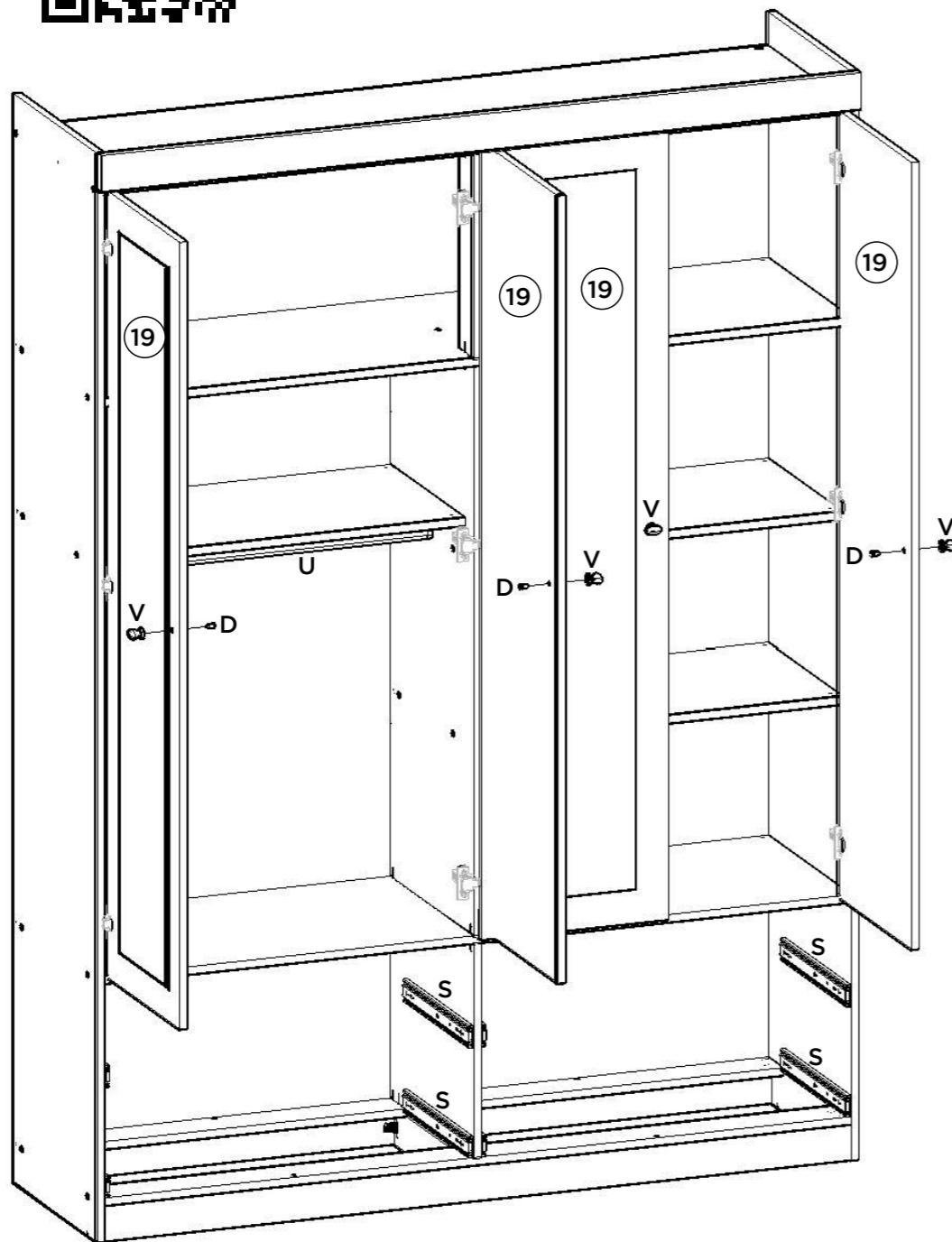
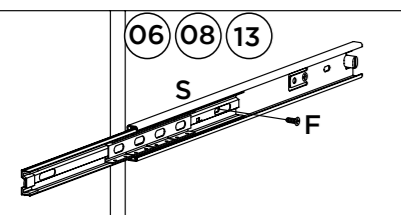
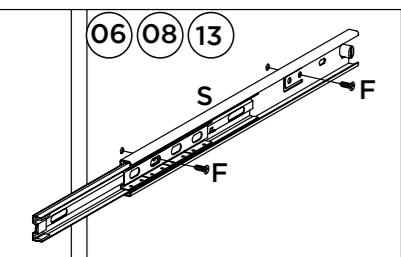
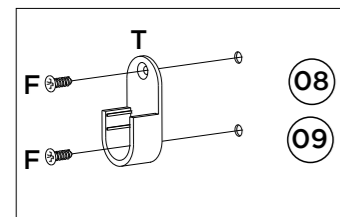
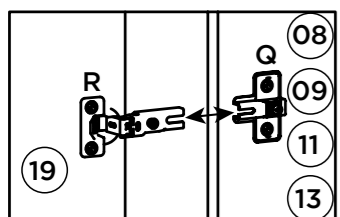
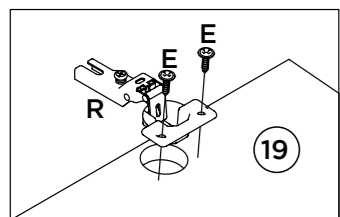
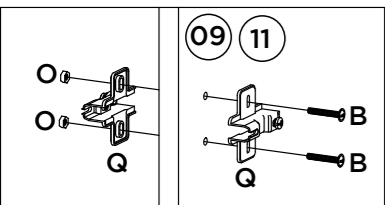
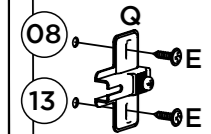

Para a desmontagem da corrediça siga a instrução ao lado.

Para el desmontaje seguimiento de diapositivas la instrucción siguiente a.

For the dismount of the sliding onem follows the instruction aside.

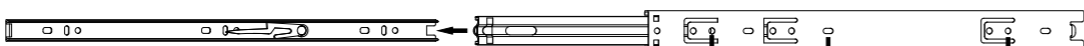
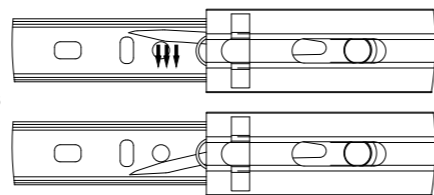

Fixar as corrediças nessas furações
Fijar las diapositivas de estos agujeros
Fix slides in these drillings

Vídeo: Dicas para fixar a Corrediça

Video: Consejos para arreglar la diapositiva

Video: Tips for Fixing the Slide

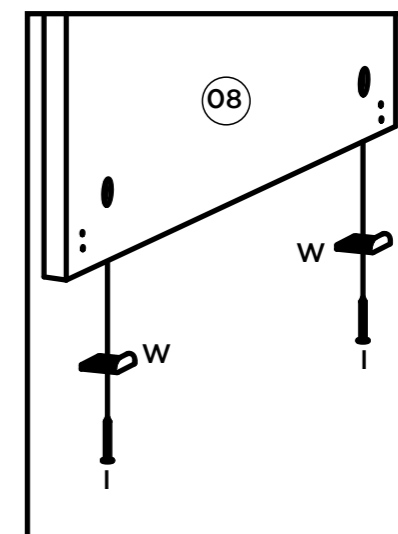
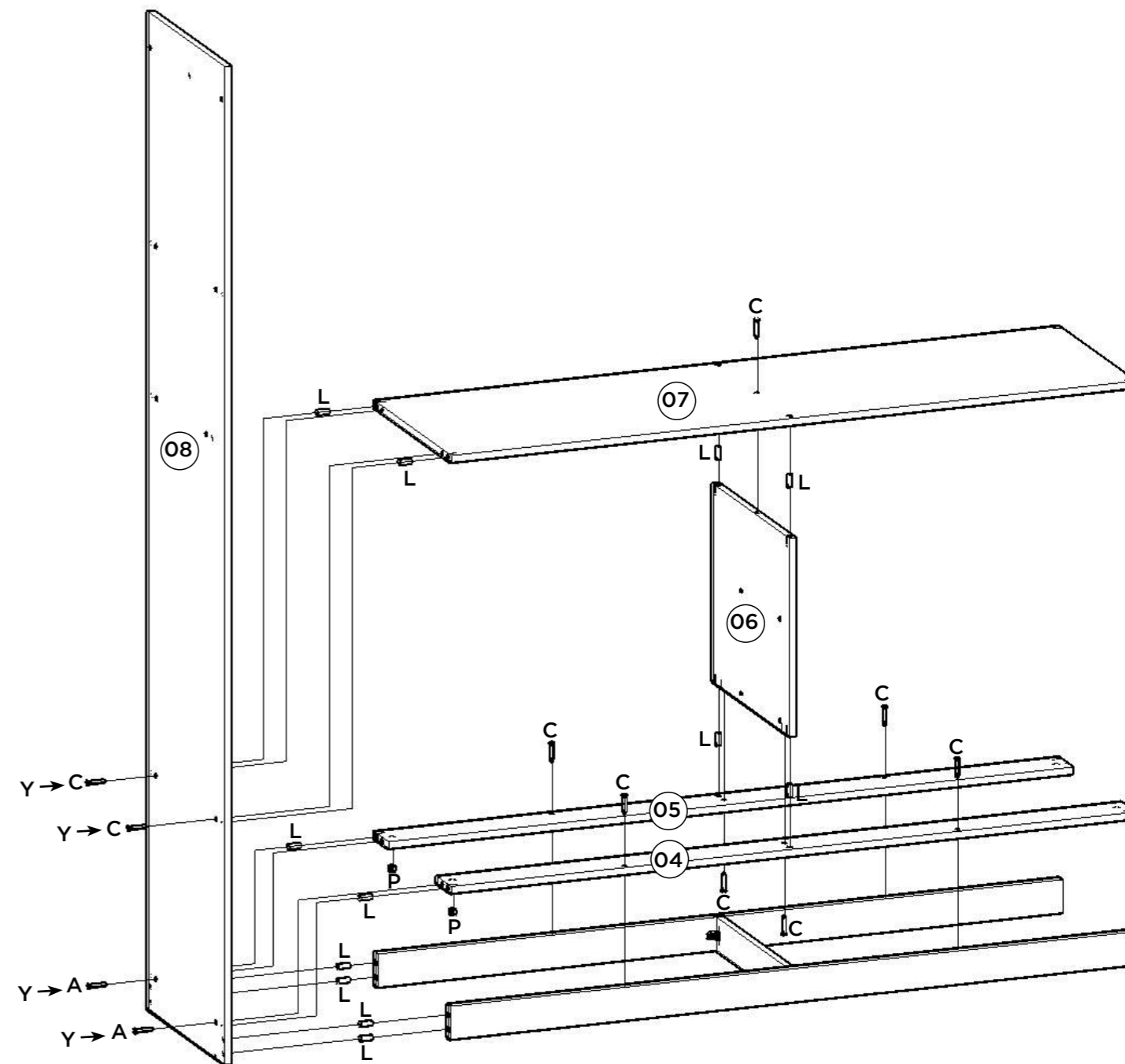

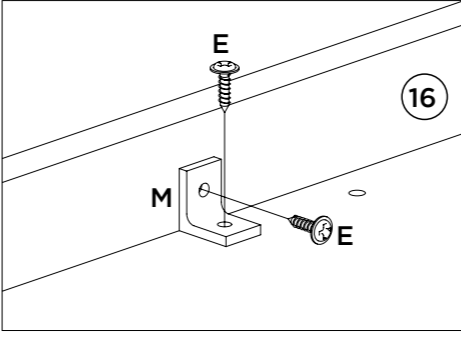
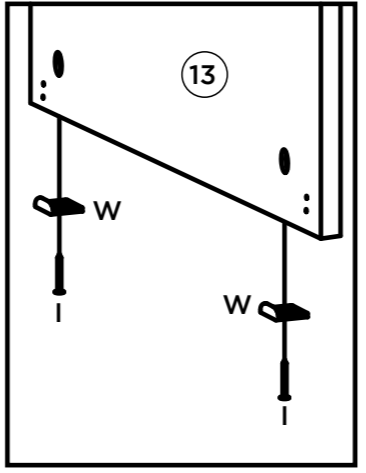
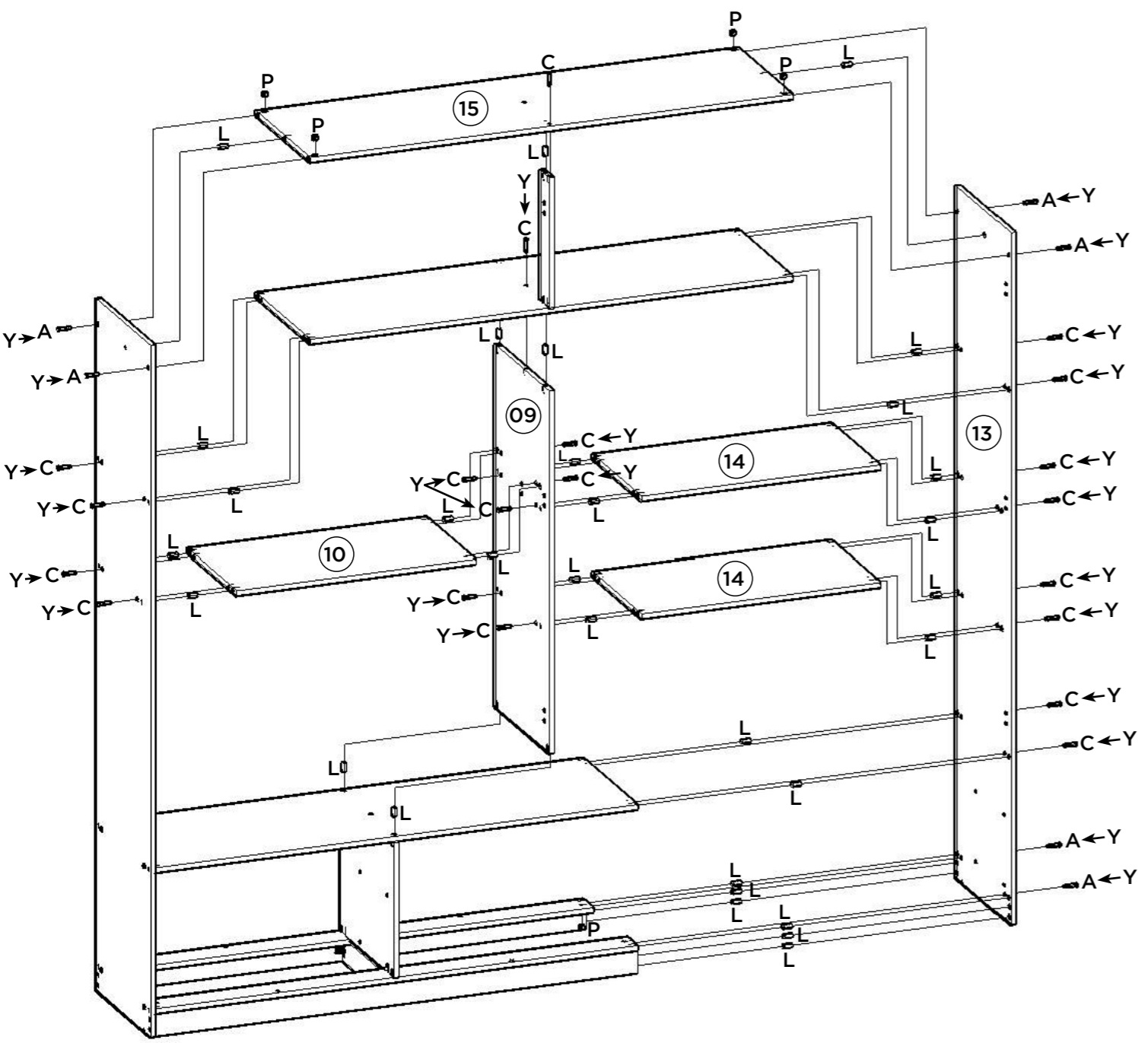

Fixar os pregos a 100mm de distância de um para outro.

Fijar las uñas a 100 mm distancia uno de otro.

Fix the nails 100mm apart from one another.

