

MANUAL DE MONTAGEM / ASSEMBLY INSTRUCTIONS / PLANO DE ARMADO

Antes de montar o móvel, leia com atenção o manual de montagem!
Before assembling the furniture, carefully read the assembly instructions!
Antes de armar el mueble, lea con atención el manual de ensamble!

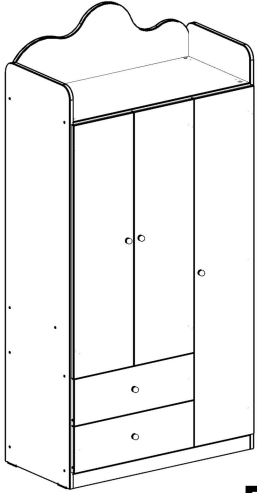

Ref.: 0937

geniaflex
ambientes incríveis para todos

Parabéns! Você comprou um produto de excelente qualidade, fabricado com chapa de madeira de MDP ou MDF, extraída de florestas renováveis. Possui alta resistência e design atual.

Congratulations! You have purchased a product of excellent quality, made from MDP or MDF wood veneer, extracted from renewable forests. It has high strength and current design.

Felicitaciones! Usted compró a un producto de excelente calidad, fabricado con placa de madera de MDP o MDF, proveniente de florestas renovables. Tiene alta resistencia y diseño actual.



**ATENÇÃO
ATTENTION
ATENCIÓN**

1) Verifique todas as peças antes de começar a montagem.

Check all parts before starting assembly.

Verifique todas las partes antes de empezar el armado.

2) Ao começar a montagem, não apoie as peças na parede.

When starting the assembly, do not support the parts on the wall.

Al empezar el armado, no apoyes las partes en la pared.

3) Ao colocar as peças e ferragens de lado, cuidado para não perde-las.

When placing parts and hardware aside, be careful not to lose them.

Al poner las piezas y herrajes a parte, cuidado para no dañarlas.

4) O móvel deve ser montado no chão, para isso, use a própria caixa para proteger e não danificar o piso.

The furniture must be mounted on the floor, to do this, use the box itself to protect and not damage the floor.

El mueble suele ser armado al piso, para eso, use la propia caja para protegerlo y no dañar al piso.

5) Comece a montagem seguindo as instruções passo a passo.

Begin assembly by following the step-by-step instructions.

Comience el armado siguiendo la instrucciones paso a paso.

6) É de responsabilidade do montador seguir as intrucões desse manual, que são fundamentais para a estrutura do móvel.

It's the assembler's responsibility to follow the instructions in this manual, which are fundamental to the structure of the furniture.

Es de responsabilidad del armador seguir las instrucciones de este manual, que son fundamentales para la estructura del mueble.

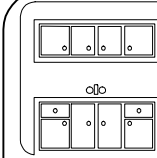

**CUIDADOS
CARE
CUIDADO**

1) A conservação e limpeza deve ser feita com um pano levemente umedecido com água.

Care and cleaning should be done with a cloth slightly moistened with water.

La conservación y limpieza debe ser hecha con un trapo levemente humedecido en agua.

2) Não use produtos abrasivos, como saponáceo, detergentes e esponja de aço.

Do not use abrasive products, such as soap, detergents and steel sponge.

No use productos abrasivos, como saponáceo, detergentes y esponja de acero.

3) Não use cera ou óleo para dar brilho ao móvel.

Do not use wax or oil to shine the furniture.

No use cera o aceites para darle brillo al mueble.

4) Não expor o móvel a interpéries e nem ao calor excessivo.

Do not expose the furniture to weather or excessive heat.

No exponer el mueble a interperies ni al calor excesivo.

5) Ao terminar a montagem, limpe o ambiente e o móvel.

When the assembly is finished, clean the room and the furniture.

Al terminar el armado, limpie al ambiente y al mueble.

FERRAMENTAS / TOOLS / HERRAMIENTAS



MARTELO
HAMMER
MARTILLO



CHAVE PHILLIPS
PHILLIPS SCREWDRIVER
LLAVE PHILLIPS



NAO RECOMENDAVEL
NOT ADVISABLE
NO RECOMENDABLE



MARTELO DE BORRACHA
RUBBER HAMMER
MARTILLO GOMA



TRENA
MEASURING TAP
CINTA MÉTRICA

PEÇAS / PARTS / PIEZAS

| Nº No Num | DESCRIÇÃO DESCRIPTION DESCRIPCIÓN | QTD QTY CANT |
|-----------------|--|--------------------|
| 1 | BASE / TAMPO BASE / LOWER TOP BASE / TABLERO | 1 |
| 2 | TAMPO SUPERIOR UPPER TOP TAPA UPERIOR | 1 |
| 3 | LATERAL ESQUERDA LEFT SIDE LATERAL IZQUIERDA | 1 |
| 4 | LATERAL DIREITA RIGHT SIDE LATERAL DERECHA | 1 |
| 5 | DIVISÓRIA DIVISION DIVISORIA | 1 |
| 6 | PRATELEIRA FIXA MAIOR FIXED BIGGER SHELF ESTANTE FIJA MAJOR | 1 |
| 7 | PRATELEIRA FIXA MENOR SMALLER FIXED SHELF ESTANTE FIJA MENOR | 1 |
| 8 | PRATELEIRA DIREITA RIGHT SHELF ESTANTE DERECHA | 2 |
| 9 | RODAPÉ FRONTAL FRONT BASEBOARD ZÓCALO FRONTAL | 1 |
| 10 | RODAPE TRASEIRO BACK BASEBOARD ZÓCALO TRASERO | 1 |
| 11 | PORTA MAIOR BIGGER DOOR PUERTA MAJOR | 1 |
| 12 | PORTA MENOR SMALLER DOOR PUERTA MENOR | 2 |
| 18 | FRENTE DE GAVETA DRAWER FRONT FRENTE DEL CAJÓN | 2 |
| 19 | LATERAL DE GAVETA DRAWER SIDE LATERAL DEL CAJÓN | 4 |
| 20 | TRASEIRO DE GAVETA DRAWER BACK TRASERO DEL CAJÓN | 2 |
| 21 | FUNDO DE GAVETA DRAWER BOTTOM FONDO DEL CAJÓN | 2 |
| 22 | COSTA BACK PANEL DORSO TRASERO | 3 |
| 23 | RODAPÉ CENTRAL CENTRAL BASEBOARD ZOCALO CENTRAL | 1 |
| 24 | PAINEL NUVEM CLOUD PANEL PANEL DE NUBE | 1 |

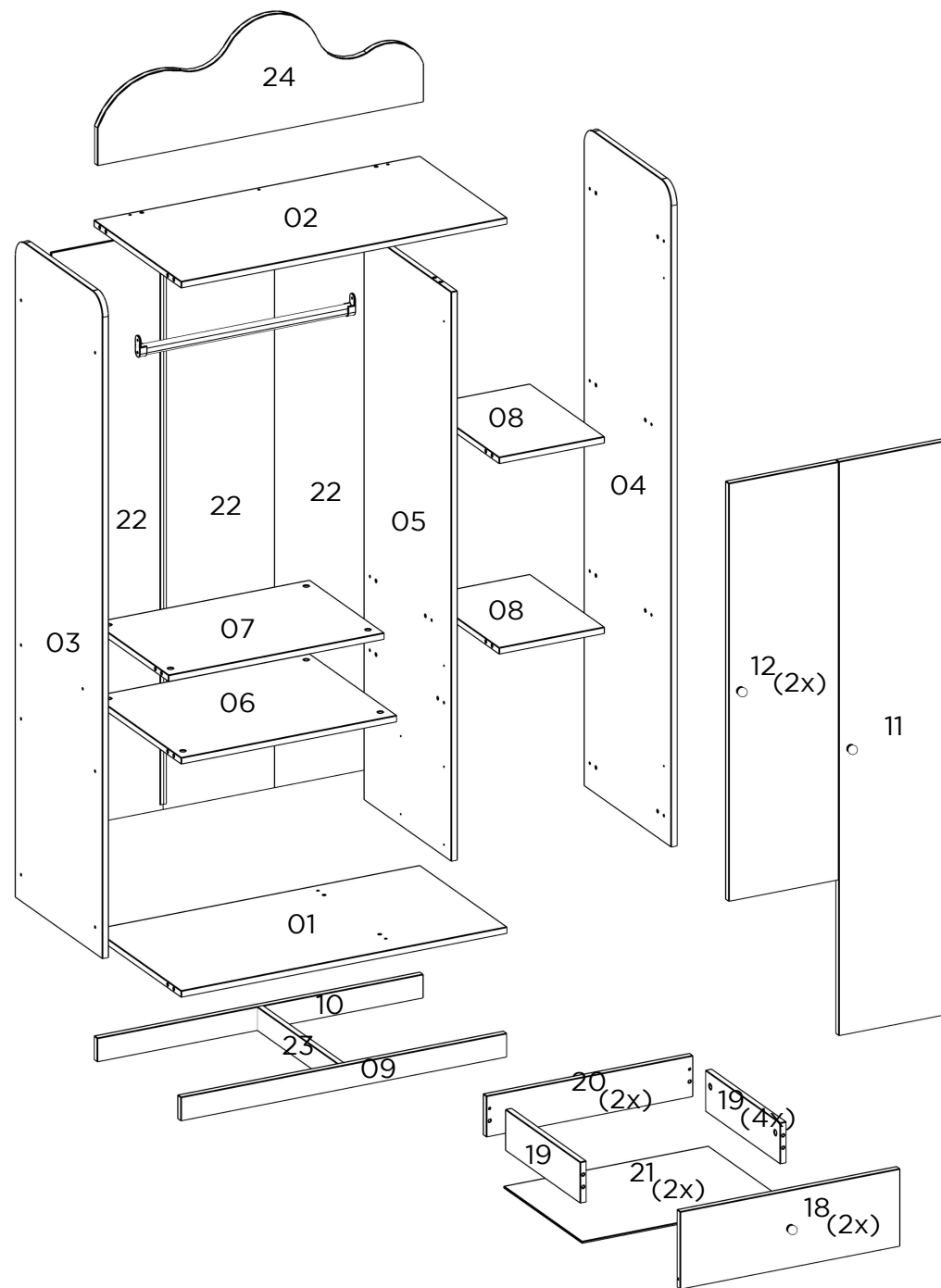

FERRAGENS / HARDWARE / HERRAJES

| CÓD CODE COD | DESCRIÇÃO DESCRIPTION DESCRIPCIÓN | QTD QTY CANT |
|--------------------|--|--------------------|
| A | CAVILHA WOODEN DOWEL TARUGO | 38 |
| B | PARAFUSO MINIFIX MINIFIX SCREW TORNILLO MINIFIX | 32 |
| C | PARAFUSO 3,5X40mm SCREW 3,5X40mm TORNILLO 3,5X40mm | 3 |
| D | TAMBOR MINIFIX MINIFIX DRUM TAMBOR MINIFIX | 32 |
| E | SUPORTE DE CABIDEIRO HANGER SUPPORT SUPORTE PARA PERCHAS | 2 |
| F | PARAFUSO 4X14mm SCREW 4X14mm TORNILLO 4X14mm | 80 |
| G | PREGO NAIL CLAVO | 80 |
| H | PERFIL I MAIOR BIGGER PROFILE I PERFIL I MAJOR | 1 |
| I | SAPATA PLÁSTICA PLASTIC SHOE PROTECCIÓN DE PLÁSTICO | 4 |
| J | CANTONEIRA DUPLA METALLIC ANGLE ESQUINERA DUPLA | 7 |
| K | CORREDIÇA LATERAL SIDE SLIDE CORREDERA LATERAL | 4 |
| M | PREGO ANELADO RINGED NAIL CLAVO ANILLADO | 30 |
| N | GARRA METÁLICA METALLIC CLAW GRAB METALICA | 20 |
| O | CORREDIÇA GAVETA DRAWER SLIDE CORREDERA DEL CAJÓN | 4 |
| P | PAU DE CABIDE STICK PALO DE PERCHA | 1 |
| Q | PARAFUSO 3,5X25mm SCREW 3,5X25mm TORNILLO 3,5X25mm | 5 |
| S | PUXADOR PULLER TIRADOR | 5 |
| T | DOBRADIÇA HINGE BIZAGRA | 7 |
| U | CALÇO PARA DOBRADIÇA HINGE SHED CALZO DE BISAGRA | 7 |
| V | TAPA FURO MAIOR BIGGER HOLE COVER TAPA AGUJERO MAJOR | 16 |

UTILIZE A RÉGUA PARA IDENTIFICAR OS PARAFUSOS
USE THE RULER TO IDENTIFY THE SCREWS
UTILICE LA REGLA PARA IDENTIFICAR LOS TORNILLOS



PESO SUPORTADO / WEIGHT SUPPORTED / PESO SOPORTADO

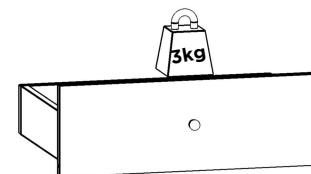
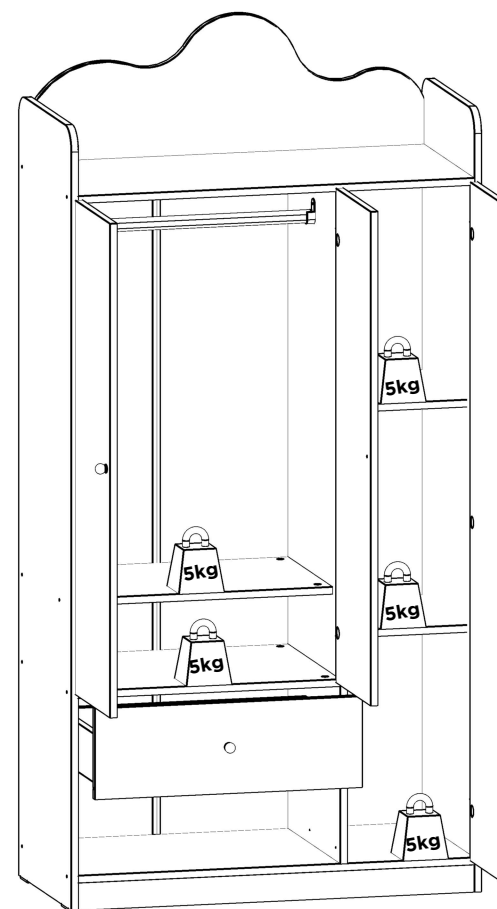

1

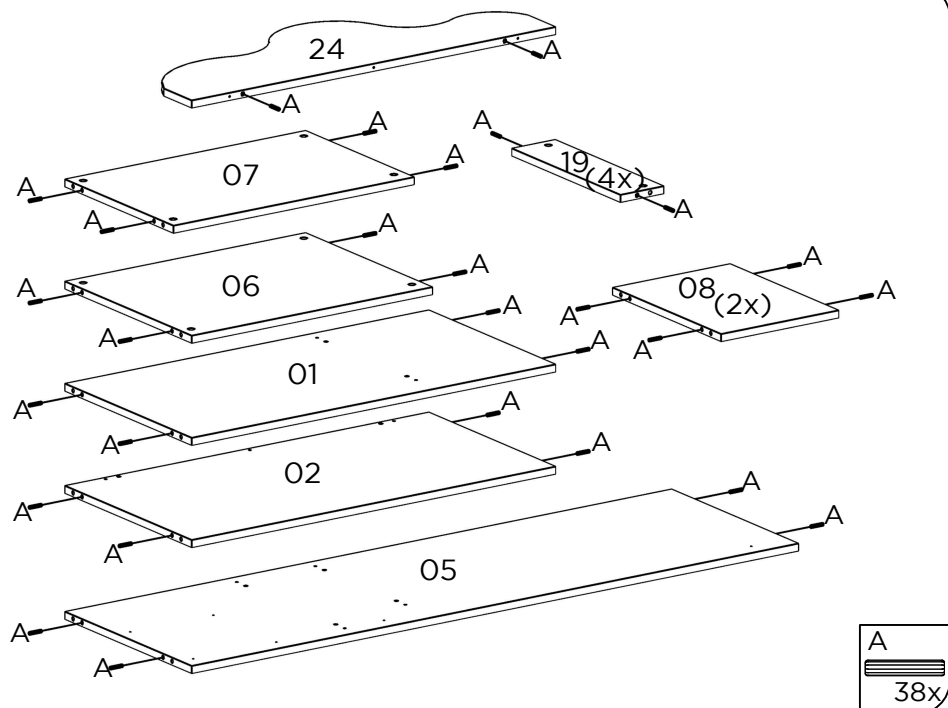

2

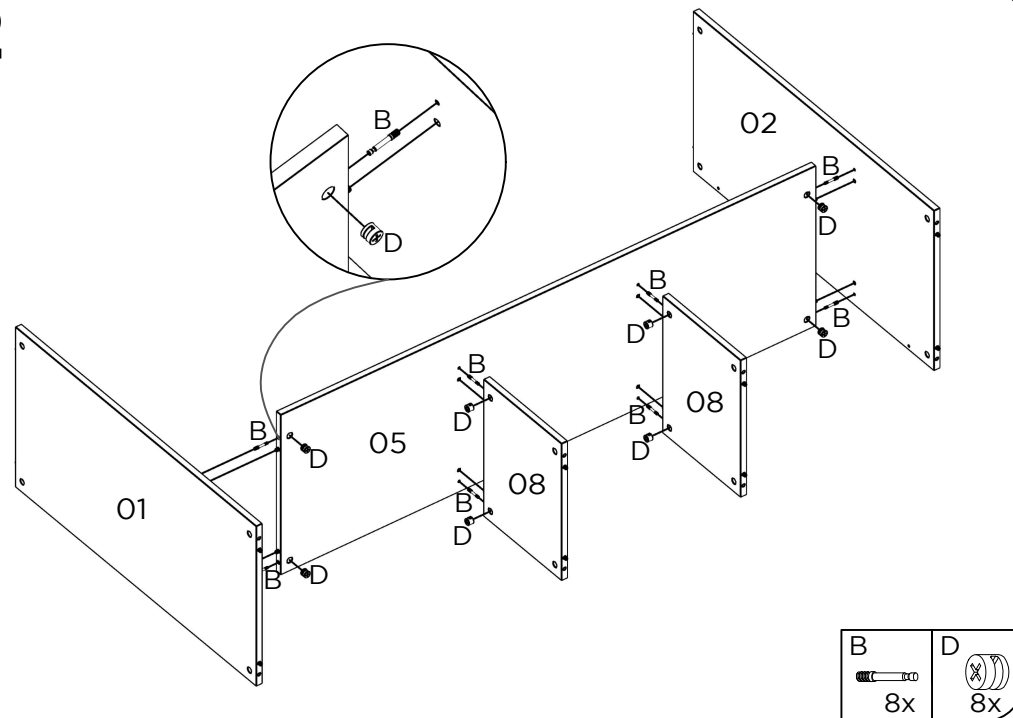

3

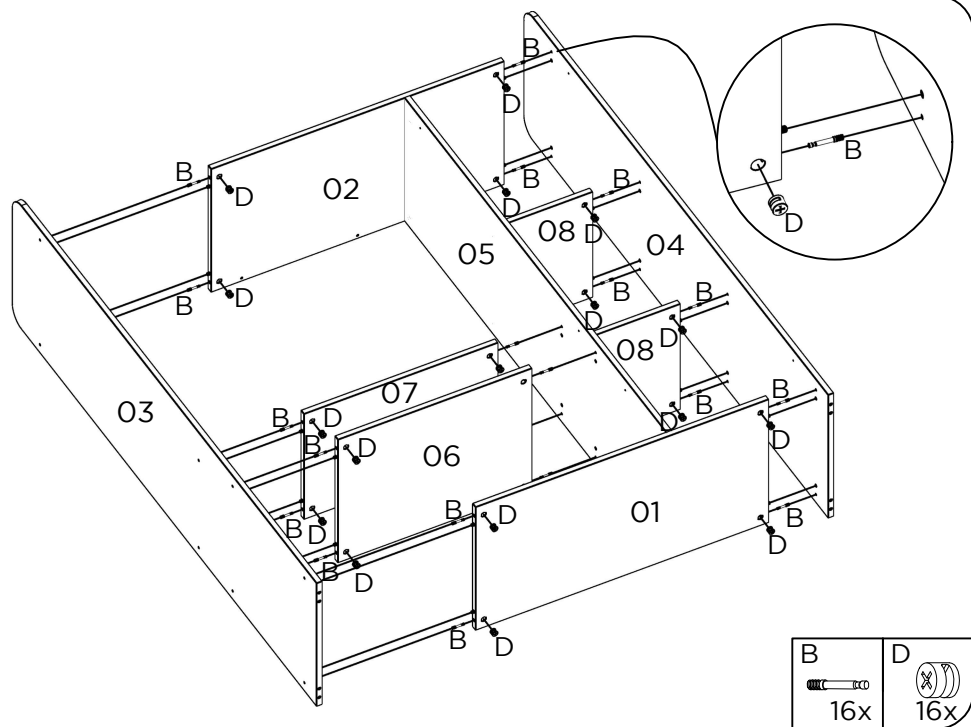

4

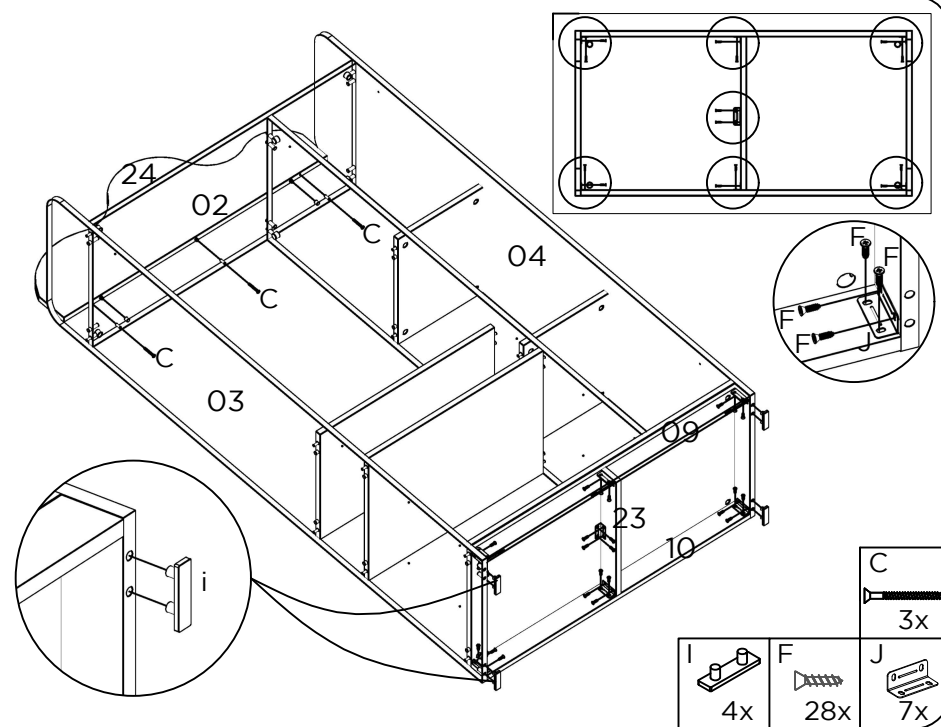

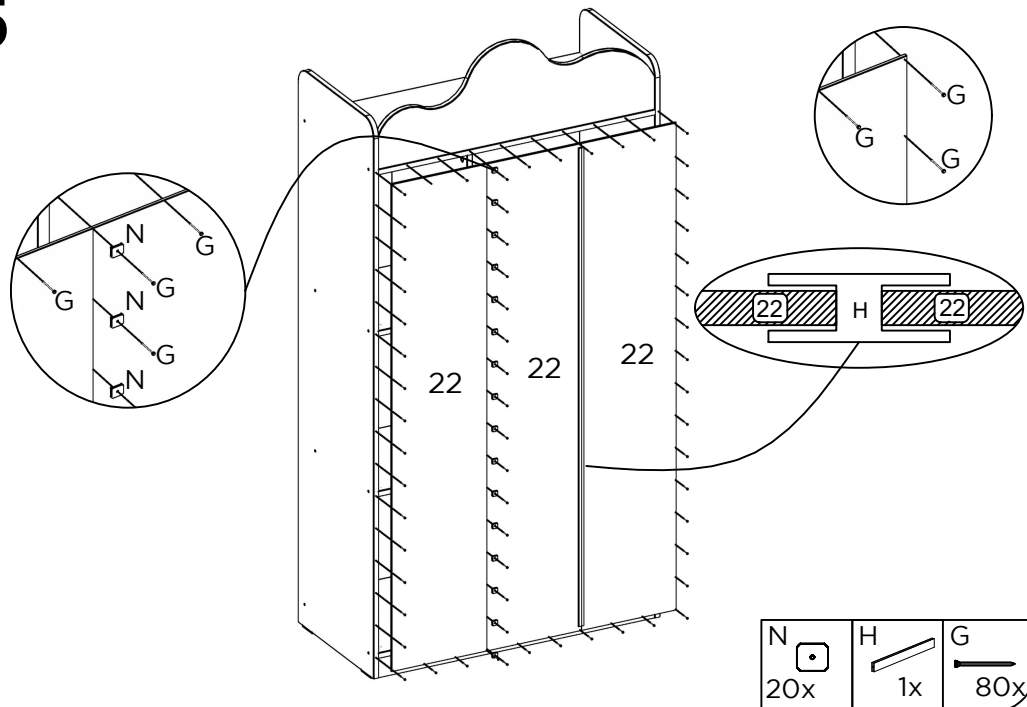
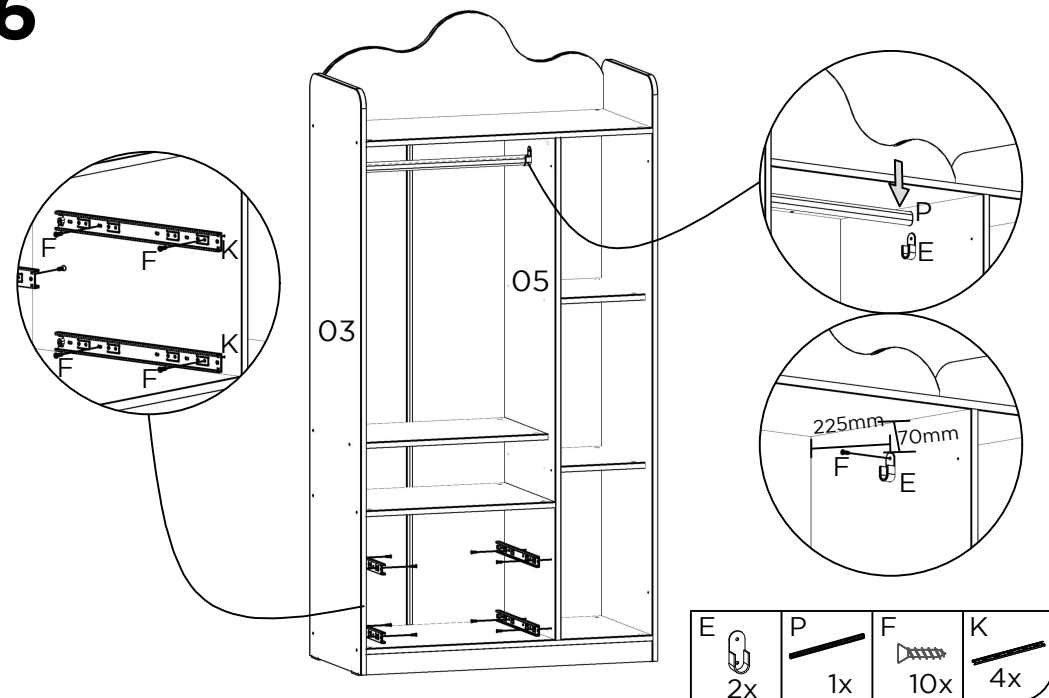
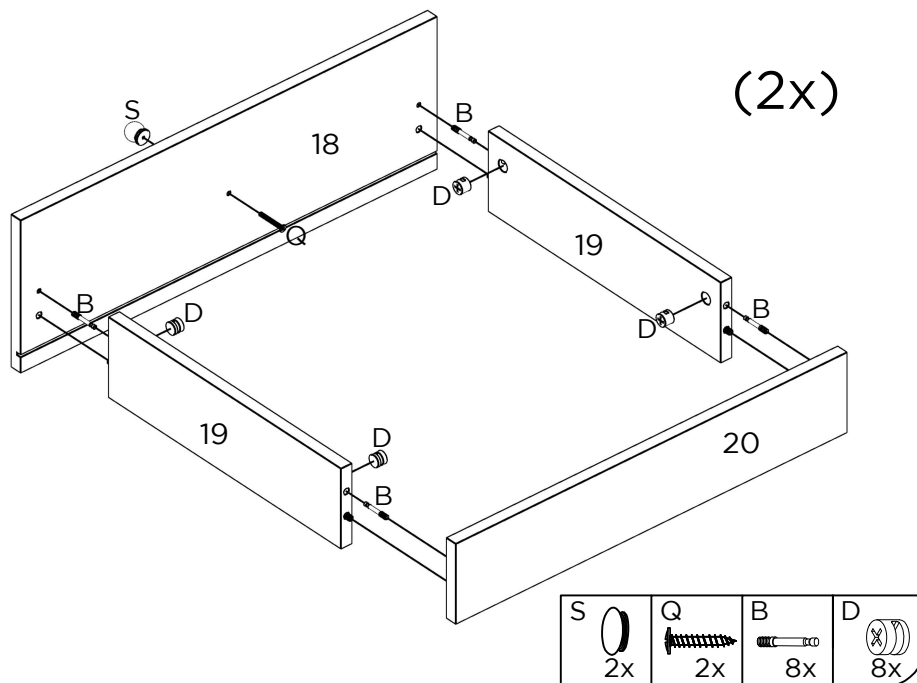
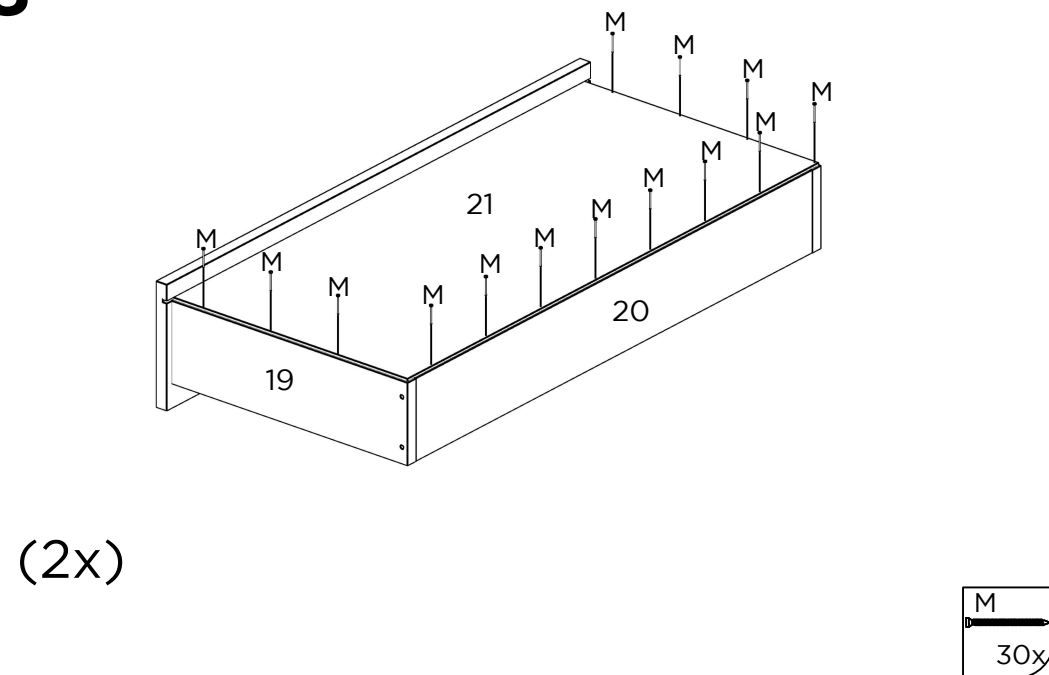
5**6****7****8**

9

SIGA AS INSTRUÇÕES NA PÁGINA DA
CORREDIÇA.
FOLLOW THE INSTRUCTIONS ON THE
SLIDE PAGE.
SIGA LAS INSTRUCCIONES EN LA PÁGINA
DE LA CORREDERA.

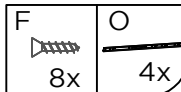
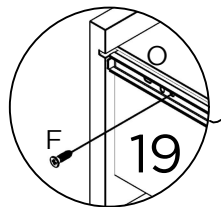
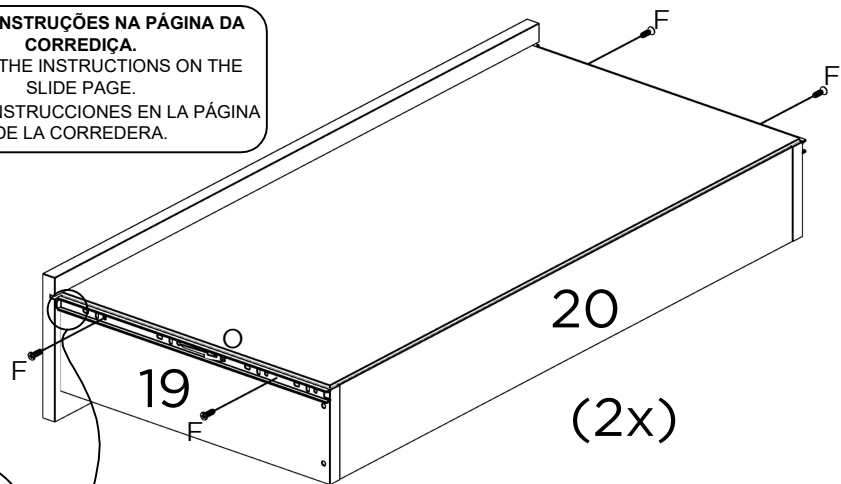
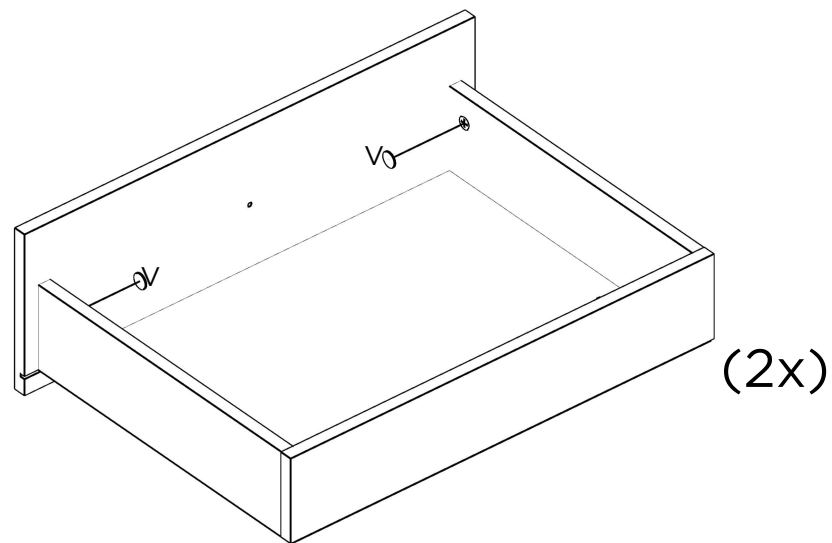
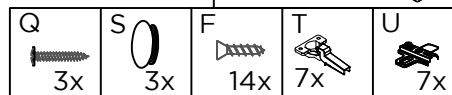
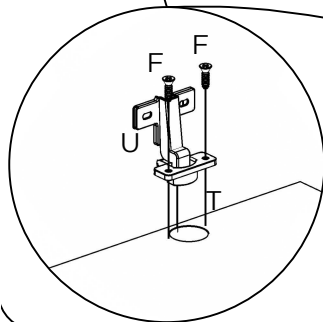
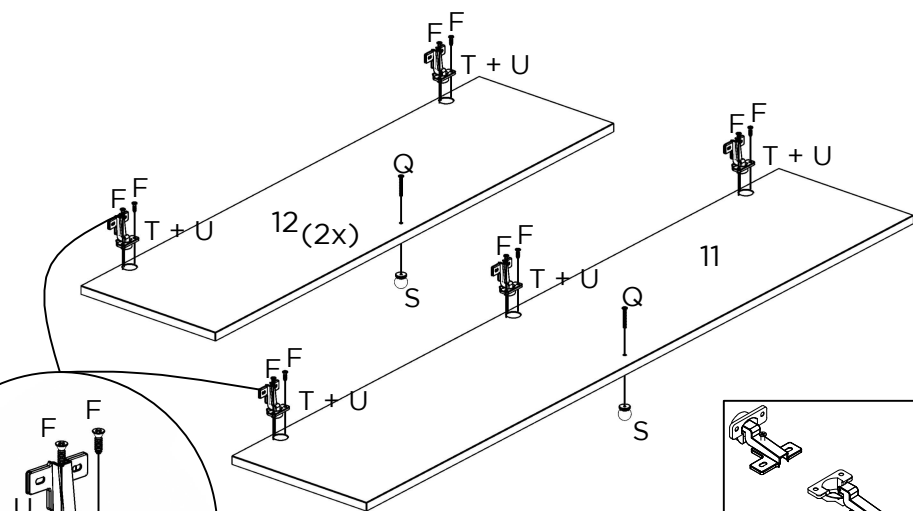
**10****11****12**