

**Roupeiro 03 Portas e 02 Gavetas com Pés / Armario 03 puertas y 02 cajones con Pies /
Wardrobe 03 doors 02 drawers with feet**

- BE16-10 Branco
- BE16-46 Preto Tex/Branco
- BE16-66 Branco/Branco/Rosa-Chá
- BE16-74 Gris/Palha
- BE16-83 Moka
- BE16-86 Branco Fosco
- BE16-87 Chocolate Fosco
- BE16-94 Rústico
- BE16-130 Castanho HP
- BE16-198 Jequitibá Brilho

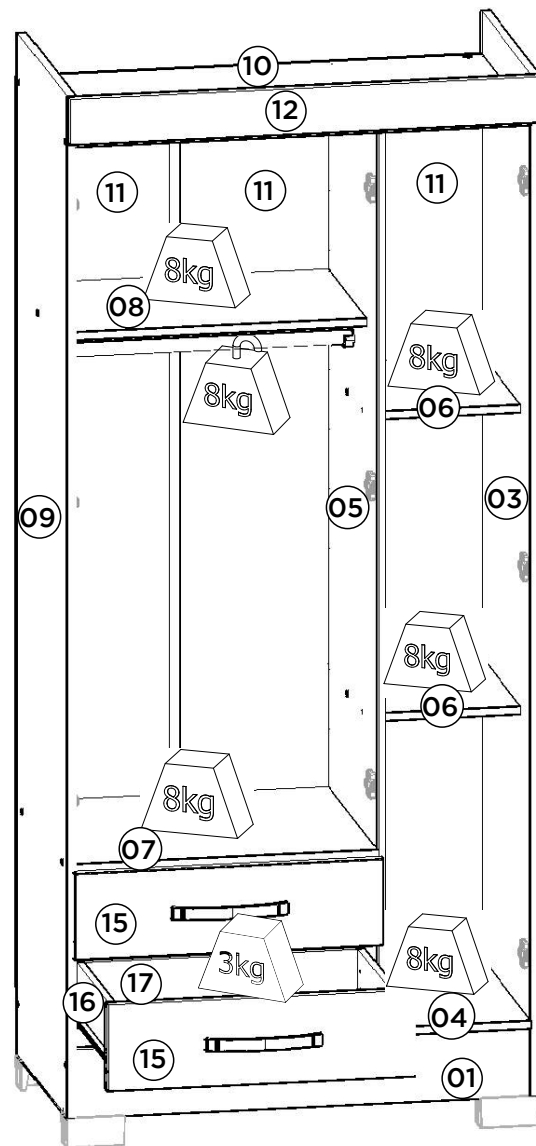

Requisitos para montagem
Requisitos para la montaje
Assembly Requirements

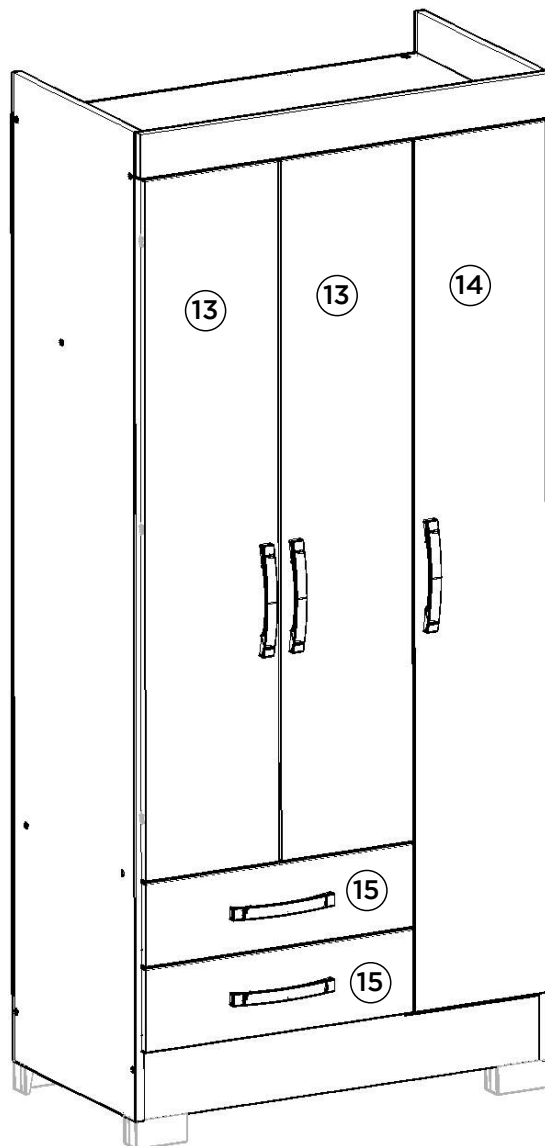
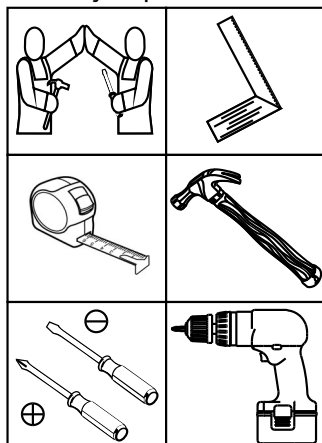

Imagens meramente ilustrativas,
não acompanha o produto.
Imágenes ilustrativas, no incluidas
con el producto.
Illustrative images, not included
with the product.

Pesos máximos recomendados com carga distribuída
Peso máximo recomendado con la carga distribuida
Recommended maximum weights with evenly distributed.

19

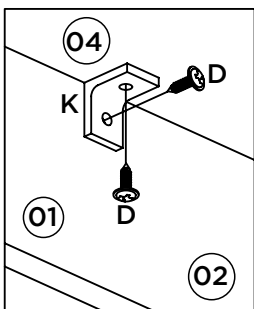
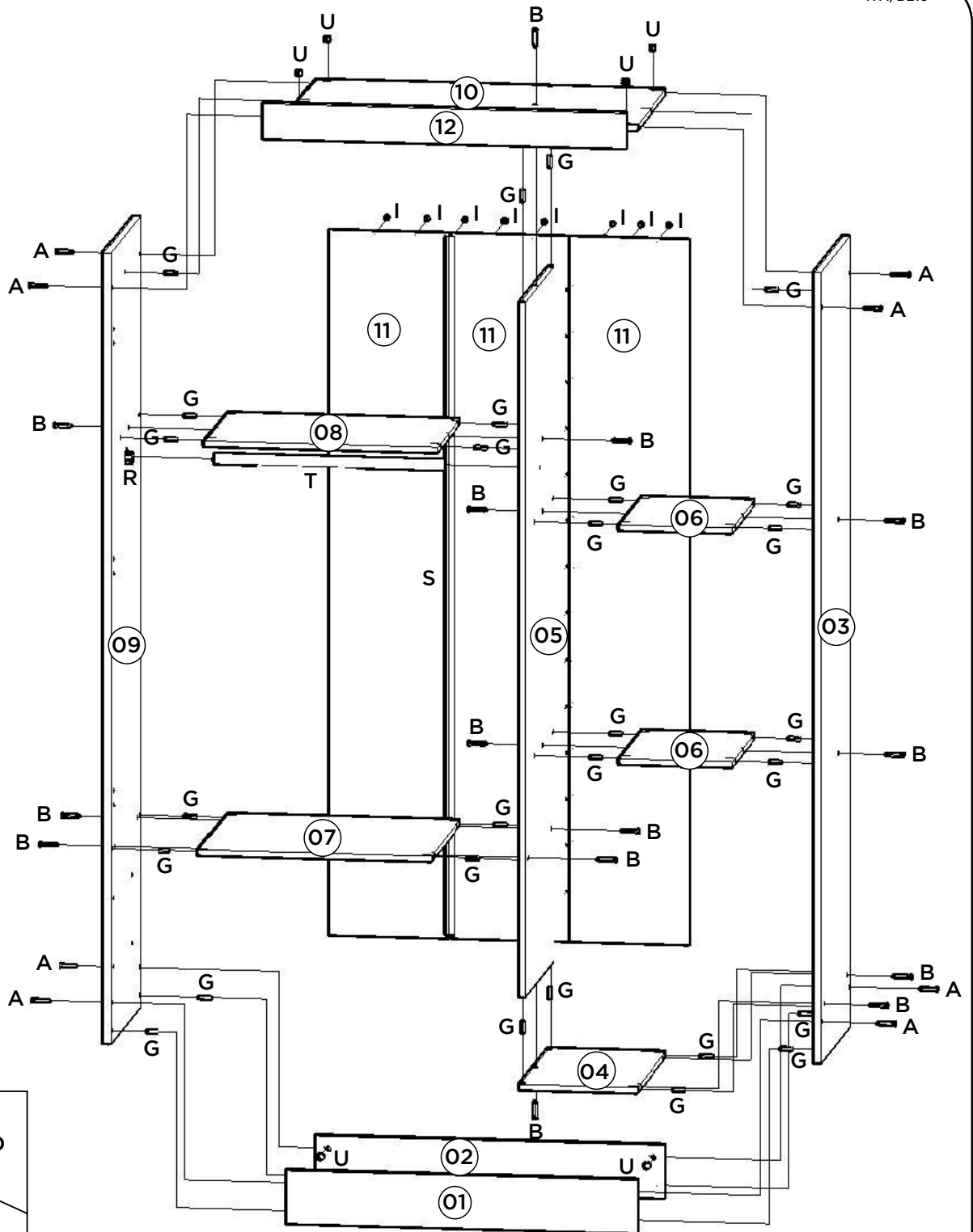
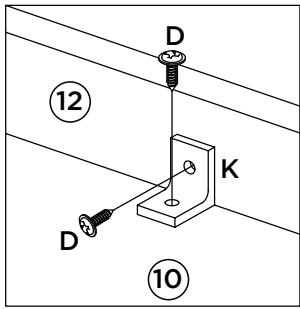

Fixação da cantoneira (K) na base (04) com os rodapés (01) e (02).

Soporte de fijación (K) la base (04) con los pies (01) y (02).

Angle bracket (K) fixing on the base (04) with the footboards (01) and (02).

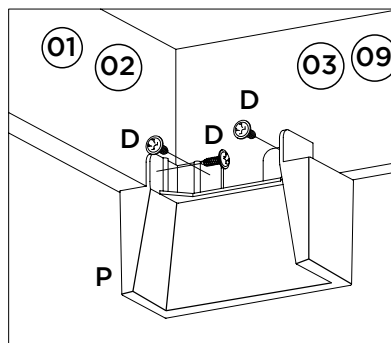

Colocação dos pés "U" (P).

La colocación de los pies "U" (P).

Placement of "U" feet (P).

2º

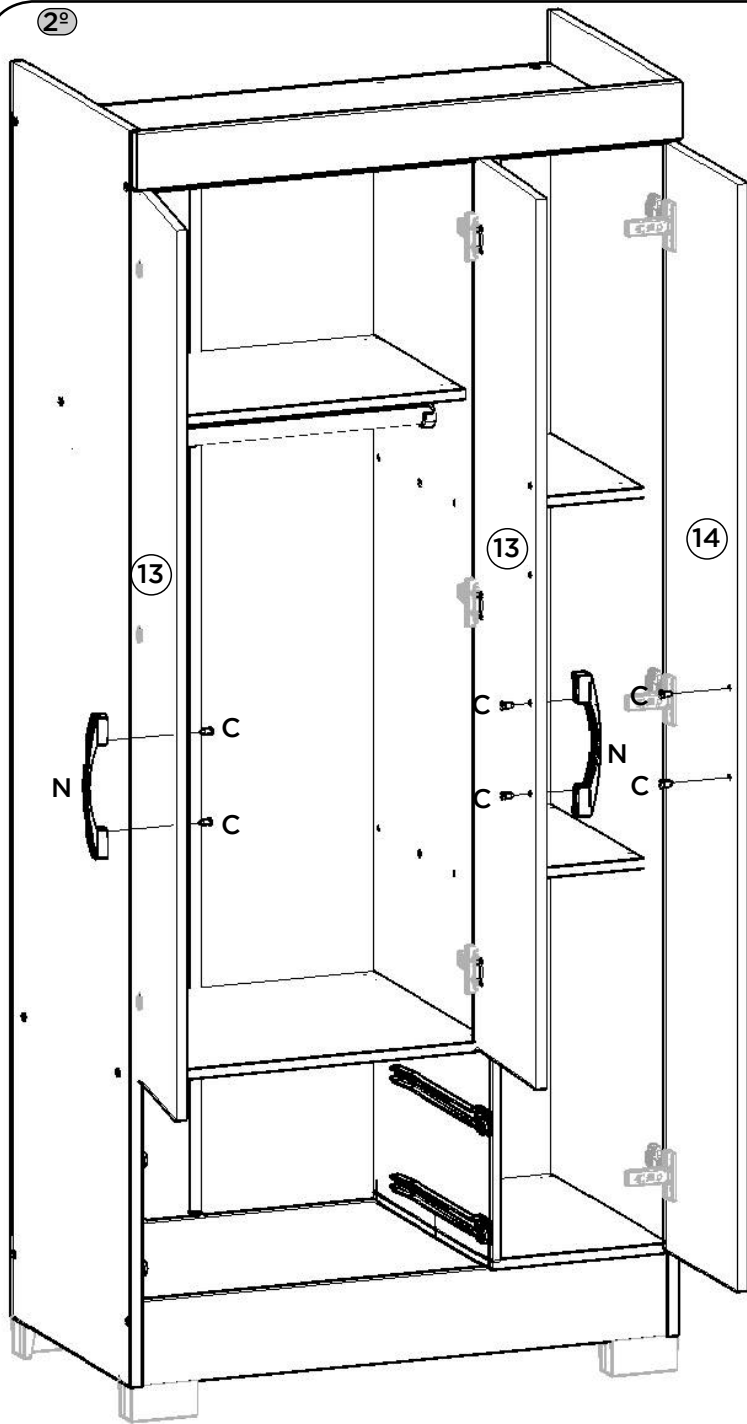

Video: Instalar e regular Dobradiças

Video: Instale y ajuste las bisagras

Video: Install and adjust hinges

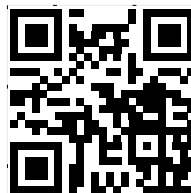
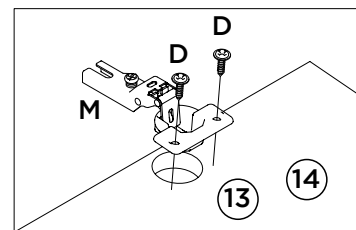
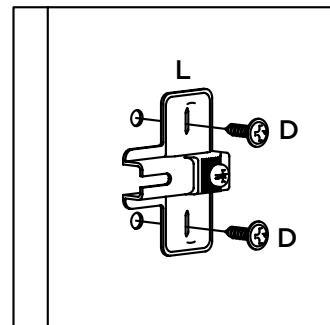
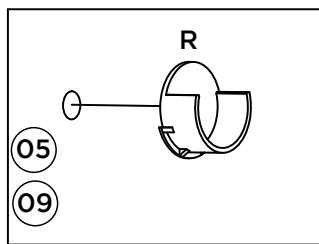

Video: Dicas para instalar corredeira

Video: consejos para instalar la diapositiva

Video: Tips for installing slide

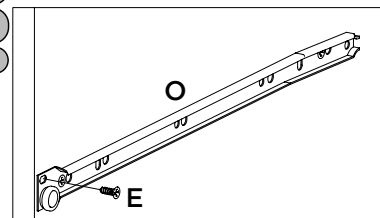
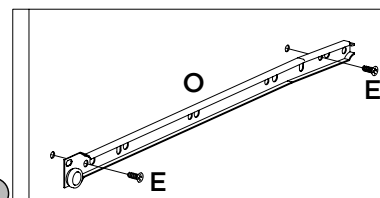



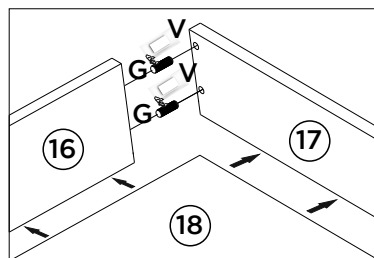
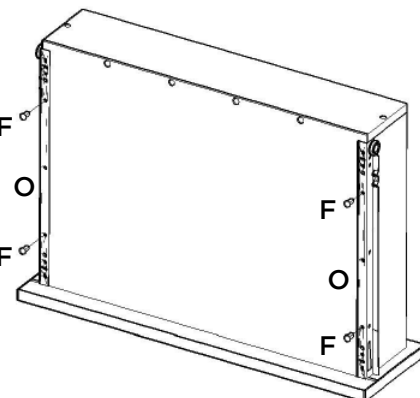
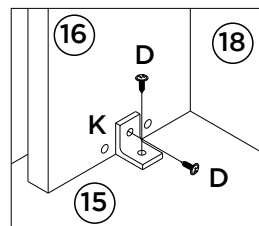
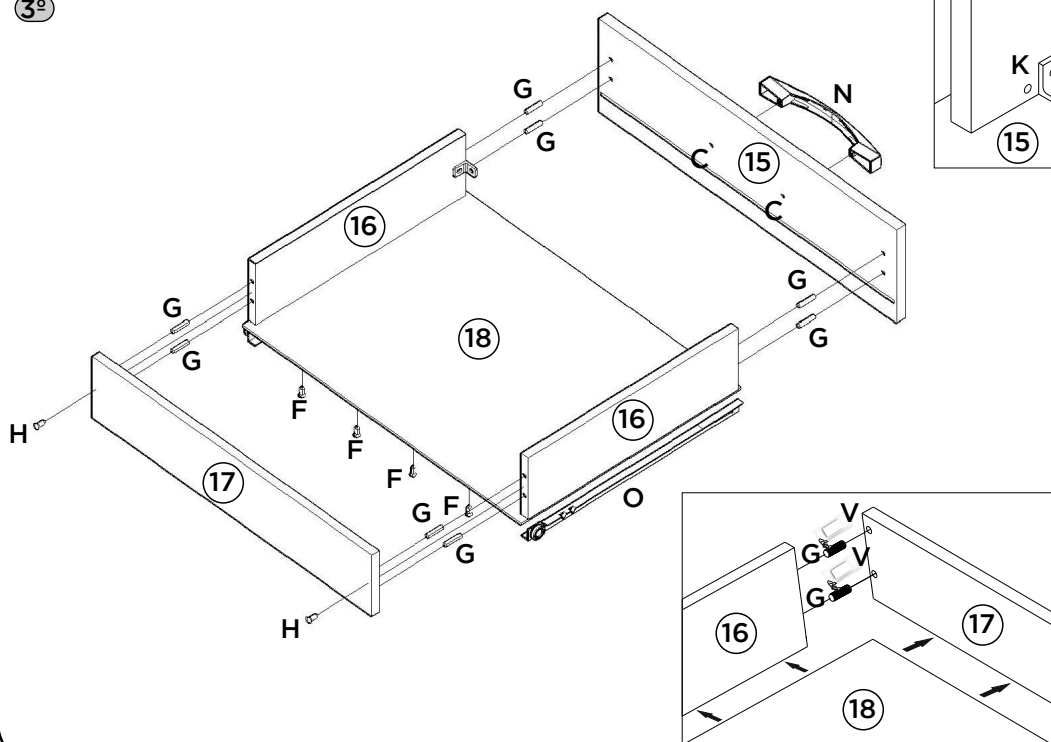













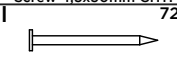
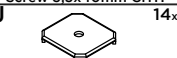

3º

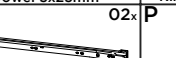

Item	Caixa Caja Box	Qtd Ctd Qty	Descrição Descripción Description	Medidas (mm) Dimensions (mm) Size (measurements) (mm)
01	1/1	01	Rodapé frontal Pie frontal Front footboard	792x120x12
02	1/1	01	Rodapé traseiro Pie trasero Rear footboard	792x120x12
03	1/1	01	Lateral direita Lateral derecho Right side	1800x445x12
04	1/1	01	Base Base Base	267x445x12
05	1/1	01	Divisão División Division	1580x445x12
06	1/1	02	Prateleira menor Estante menos Smaller tray	255x350x12
07	1/1	01	Tampa das gavetas Cubre cajones Drawer cover	525x445x12
08	1/1	01	Prateleira Estante Shelf	525x350x12
09	1/1	01	Lateral esquerda Lateral izquierdo Left side	1800x445x12
10	1/1	01	Tampo superior Panel superior Top cover	792x455x12
11	1/1	03	Fundo Fondo Bottom	1604x268x3
12	1/1	01	Chapéu Sombrero Hat	814x80x15
13	1/1	02	Porta menor puerta más pequeña Smaller door	1276x265x15
14	1/1	01	Porta Puerta Door	1588x265x15
15	1/1	02	Frente de gaveta Frente de cajón Drawer front	533x152x15
16	1/1	04	Lado de gaveta Lado del cajón Drawer side	350x100x12
17	1/1	02	Ripa de trás Malla detrás Rear batten	500x100x12
18	1/1	02	Fundo de gaveta Fondo del cajón Drawer bottom	499x367x3

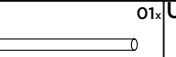
FERRAGENS | HERRAJES | HARDWARE

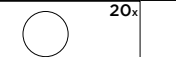
A 08x  Parafuso 4,5x50mm CHT. Tornillo 4,5x50mm CHT. Screw 4,5x50mm CHT.	B 14x  Parafuso 3,5x40mm CHT. Tornillo 3,5x40mm CHT. Screw 3,5x40mm CHT.	C 10x  Parafuso 3,5x25mm FLA. Tornillo 3,5x25mm FLA. Screw 3,5x25mm FLA.	D 66x  Parafuso 3,5x12mm FLA. Tornillo 3,5x12mm FLA. Screw 3,5x12mm FLA.	E 12x  Parafuso 3,5x12mm CHT. Tornillo 3,5x12mm CHT. Screw 3,5x12mm CHT.	F 16x  Parafuso 3,0x16mm CHT. Tornillo 3,0x16mm CHT. Screw 3,0x16mm CHT.	G 44x  Cavilha 5x25mm Cinta 5x25mm Dowel 5x25mm	H 04x  Prego 12x12mm Anelado Clavo 12x12mm Anillado Ringed Nails 12x12mm
I 72x  Prego 10x10mm Clavo 10x10mm Nail 10x10mm	J 14x  Fixador de fundos Fijador de fondos Bottom fixer	K 09x  Cantoneira plástica Cantenera plástica Plastic angle brackets	L 09x  Calço metal 5mm Calzado metálico 5mm 5mm metal shim	M 09x  Dobradiça metal 26mm Bisagra de metal 26mm 26mm metal hinge	N 05x  Puxador Indonésia 128mm Tirador Indonésia 128mm 128mm Indonésia Handle	O 02x  Corrediça metal 350mm Corredera de metal 350mm Sliding metal 350mm	P 04x  Pé "U" 50x40x100mm Pie "U" 50x40x100mm 50x40x100mm "U" feet
Q 01x  Etiqueta resinada Briz Etiqueta resinada Briz Briz resin label	R 02x  Suporte cabideiro Soporte de percha Coat hanger support	S 01x  Perfil "I" 1589mm Perfil "I" 1589mm Profile "I" 1589mm	T 01x  Cabideiro Madeira 519mm Cabezal Madera 519mm 519mm wooden hanger	U 08x  Porca cilíndrica Tuerca cilíndrica Cylindrical nut	V 01x  Sachê de cola Bolsa de pegamento Glue bag	W 20x  Adesivo tapa parafuso 10mm Adhesivo tapón de tornillo 10mm Bolt cover adhesive 10mm	

AVISO

Para limpeza de seu móvel, use uma flanela seca ou umedecida, e não utilize produtos químicos que possam danificar seu produto.

SISTEMA DE MONTAGEM

O sistema de montagem dos produtos, funciona de acordo com a ordem crescente dos números indicados no desenho. Ex: 01, 02, 03, 04... até a conclusão da montagem.

ASSISTÊNCIA TÉCNICA

Para solicitação de Assistência Técnica você consumidor deverá entrar em contato com o Lojista o qual você realizou a compra deste produto e solicitar a assistência técnica das peças avariadas. A garantia abrange todas as peças, partes e componentes que eventualmente venham apresentar defeito de fabricação no prazo de 03 (três) meses, contando a partir da entrega do produto ao consumidor, mediante nota fiscal de compra. Se houver qualquer alteração na estrutura do produto ou ocorrer defeito por negligência do montador/consumidor em relação a instrução de montagem e manuseio, não será fornecido assistência técnica gratuita.

ADVERTENCIA

Para limpieza de su móvil, use una flanela seca o húmeda, y no utilice productos químicos que puedan dañar su producto.

SISTEMA DE MONTAJE

El sistema de montaje de los productos funciona de acuerdo con el orden creciente de los números indicados en el dibujo. Ej.: 01, 02, 03, 04... hasta la conclusión del montaje.

ASISTENCIA TÉCNICA

Para solicitar Asistencia Técnica, el consumidor debe comunicarse con el Comercio que usted realizó la compra de este producto y solicita asistencia técnica para las partes dañadas. La garantía cubre todas las partes, piezas y componentes que eventualmente puedan presentar defecto de fabricación en el plazo de 03 (tres) meses, contados a partir de la entrega del producto al consumidor, mediante factura de compra. Si se produce algún cambio en la estructura del producto o se produce un defecto por negligencia del montador/consumidor en relación con las instrucciones de montaje y manipulación, no se prestará asistencia técnica gratuita.

NOTICE

To clean your furniture, use a dry or wet cloth, and do not use chemicals that may damage your product.

ASSEMBLY SYSTEM

The products' assembly system works according to the increasing order of the indicated numbers. For example: 01, 02, 03, 04 ... to the end of the assembly.

TECHNICAL ASSISTANCE

To request Technical Assistance, the consumer must contact the retailer from whom you purchased this product and request technical assistance for the damaged parts. The warranty covers all parts, parts and components that may eventually present a manufacturing defect within a period of 03 (three) months, counting from the delivery of the product to the consumer, by means of a purchase invoice. If there is any change in the structure of the product or defect occurs due to negligence of the assembler/consumer in relation to the assembly and handling instruction, free technical assistance will not be provided.