

ROUPEIRO 05 PORTAS 02 GAVETAS

ARMARIO 05 PUERTAS 02 CAJONES | WARDROBE 05 DOORS 02 DRAWERS

B60-52 CAFÉ/RÚSTICO | B60-74 GRIS/PALHA | B60-101 CAFÉ | B60-111 CAFÉ/CRISTAL

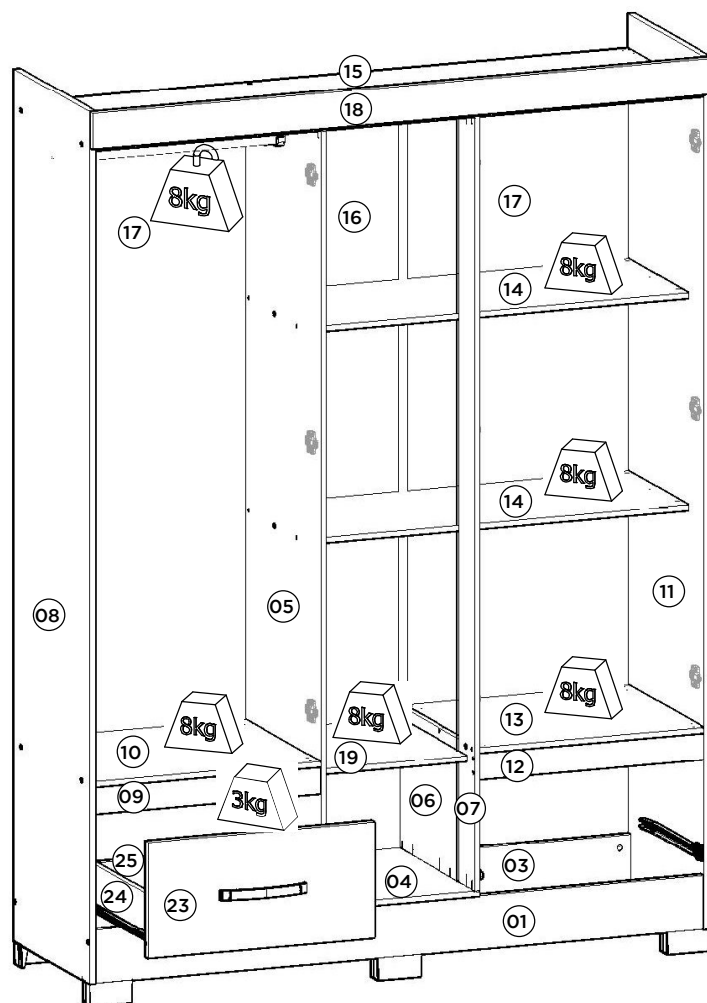
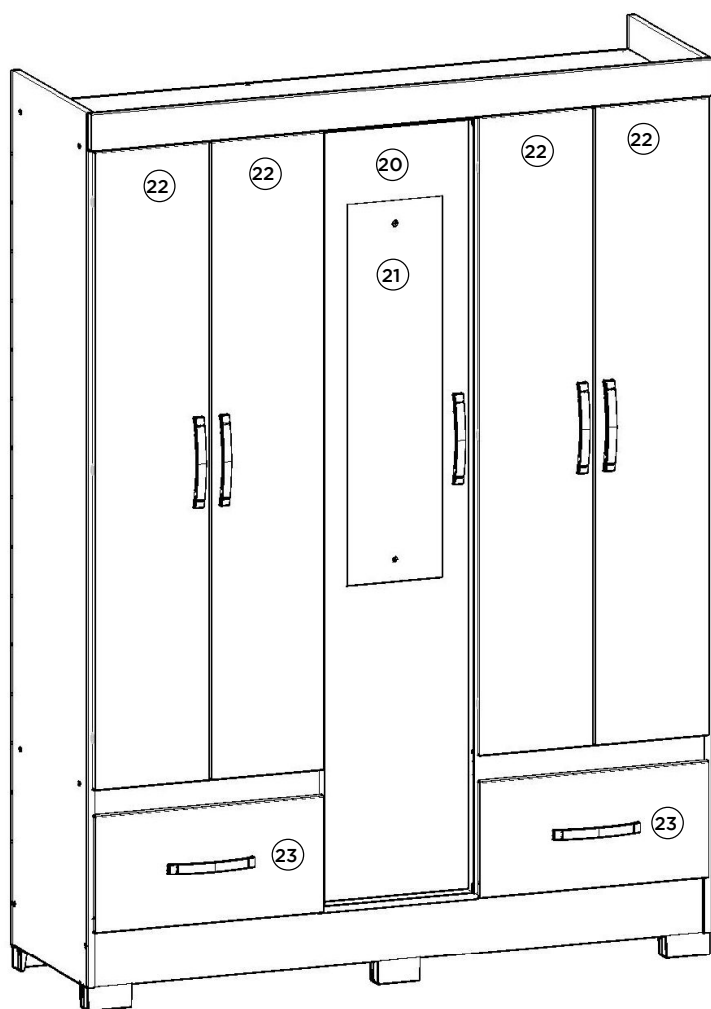

Pesos máximos recomendados com carga distribuída
Peso máximo recomendado con la carga distribuida
Recommended maximum weights with evenly distributed.

Requisitos para montagem
Requisitor para la montaje
Assembly Requirements

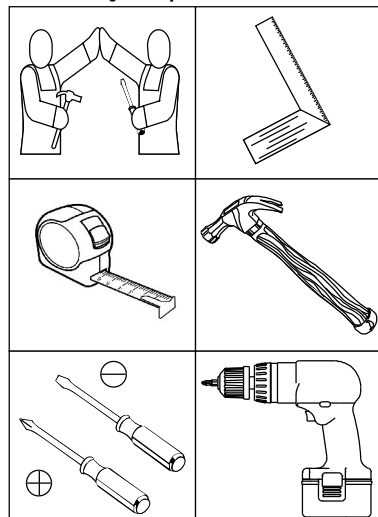

Imagens meramente ilustrativas
Imágenes meramente ilustrativas
Images for illustration only

AVISO

Para limpeza de seu móvel, use uma flanela seca ou umedecida, e não utilize produtos químicos que possam danificar seu produto.

SISTEMA DE MONTAGEM

O sistema de montagem dos produtos, funciona de acordo com a ordem crescente dos números indicados no desenho. Ex: 01, 02, 03, 04... até a conclusão da montagem.

ADVERTENCIA

Para limpieza de su móvil, use una flanela seca o húmeda, y no utilice productos químicos que puedan dañar su producto.

SISTEMA DE MONTAJE

El sistema de montaje de los productos funciona de acuerdo con el orden creciente de los números indicados en el dibujo. Ej.: 01, 02, 03, 04... hasta la conclusión del montaje.

NOTICE

To clean your furniture, use a dry or wet cloth, and do not use chemicals that may damage your product.

ASSEMBLY SYSTEM

The products' assembly system works according to the increasing order of the indicated numbers. For example: 01, 02, 03, 04 ... to the end of the assembly.

1º

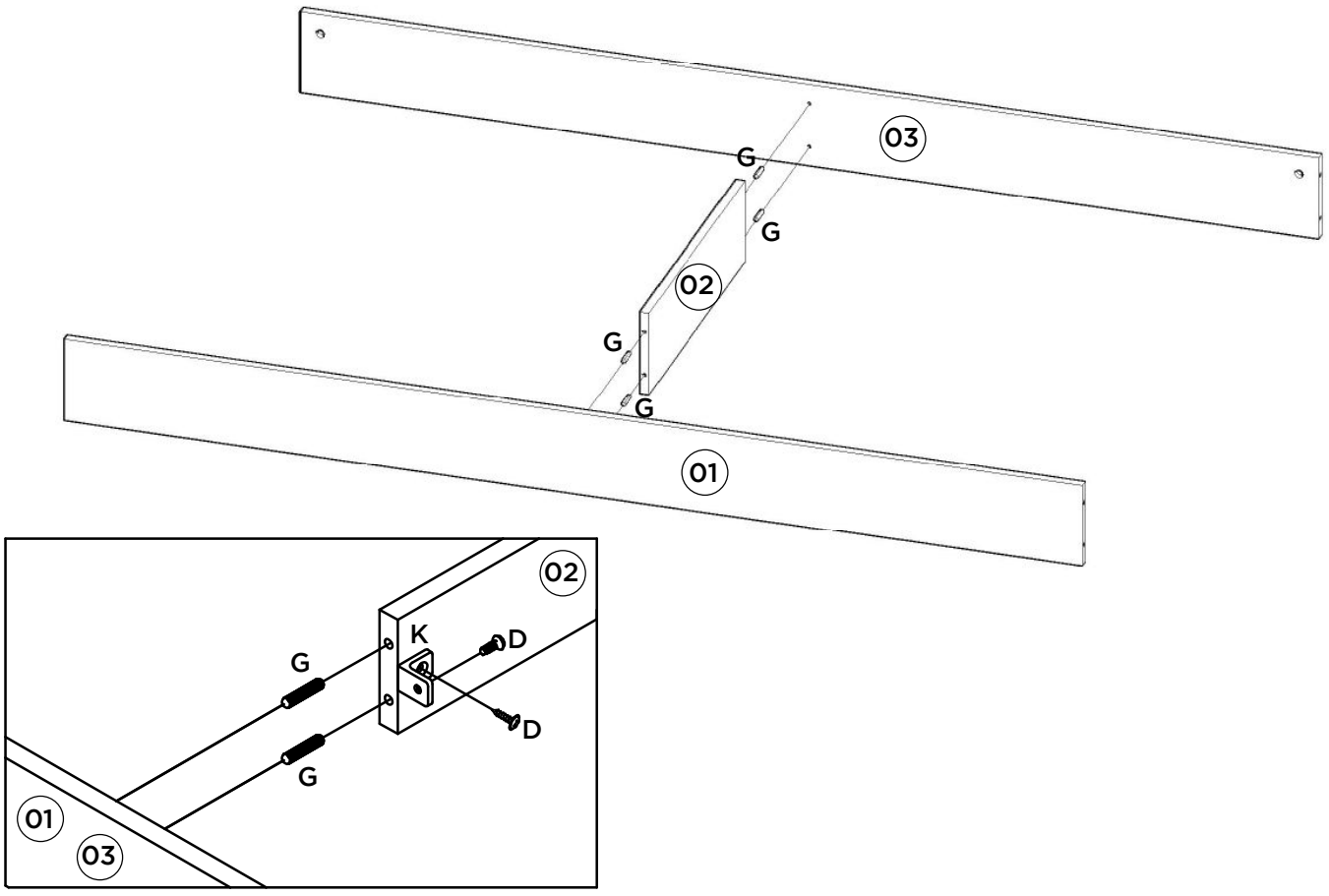

2º

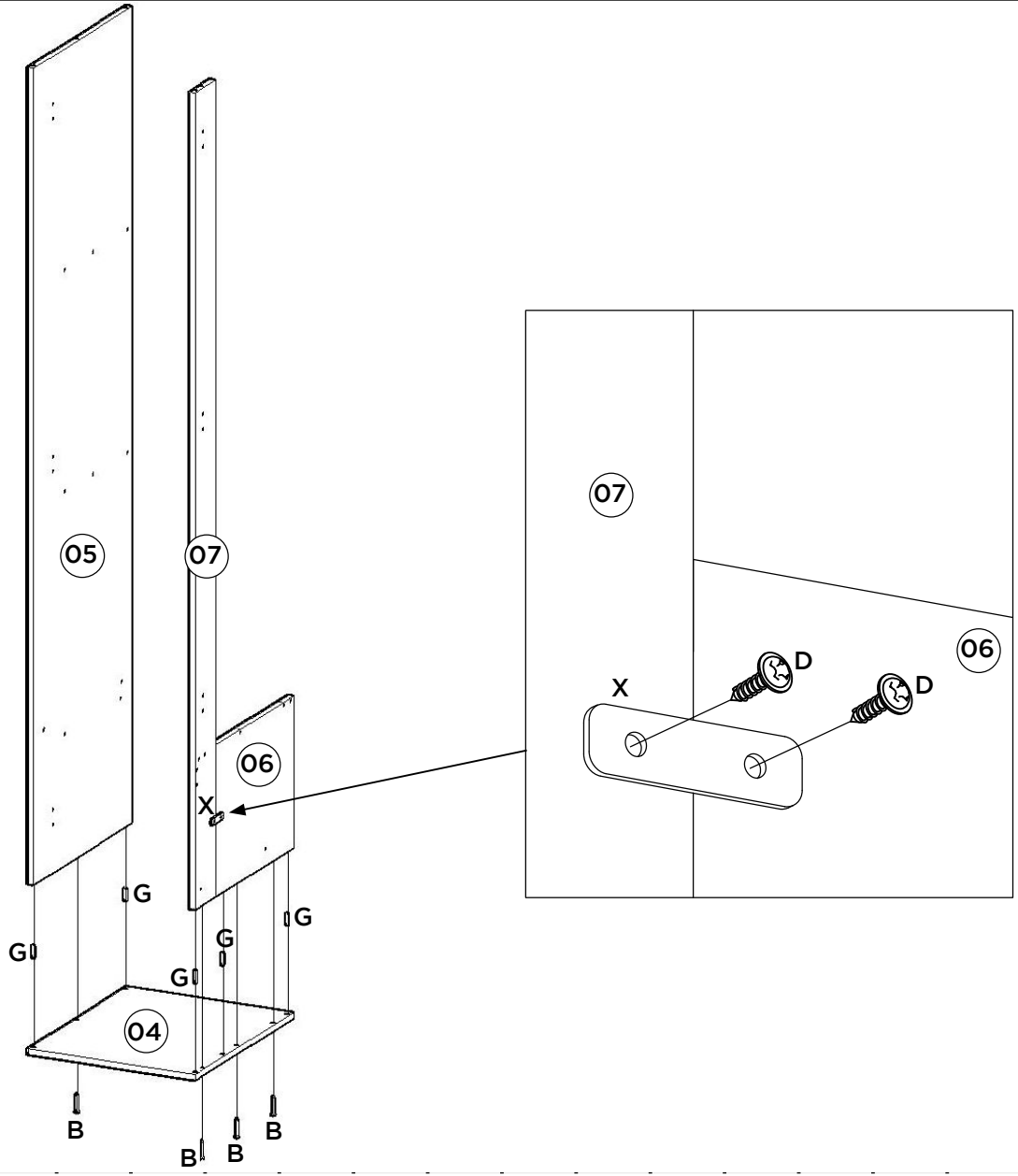

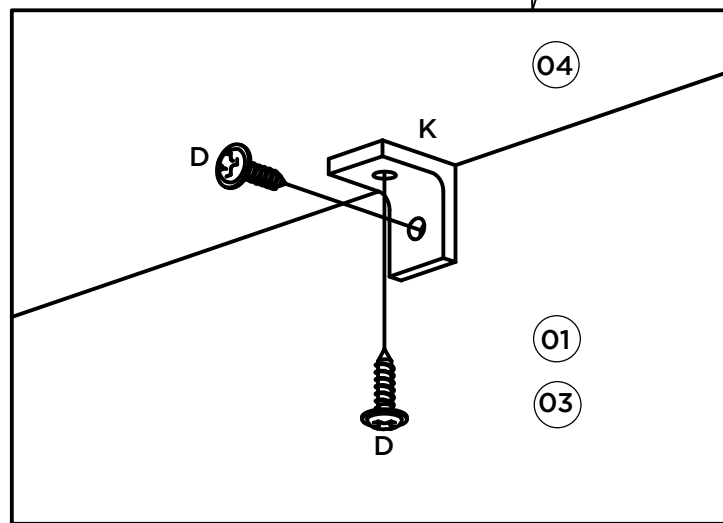
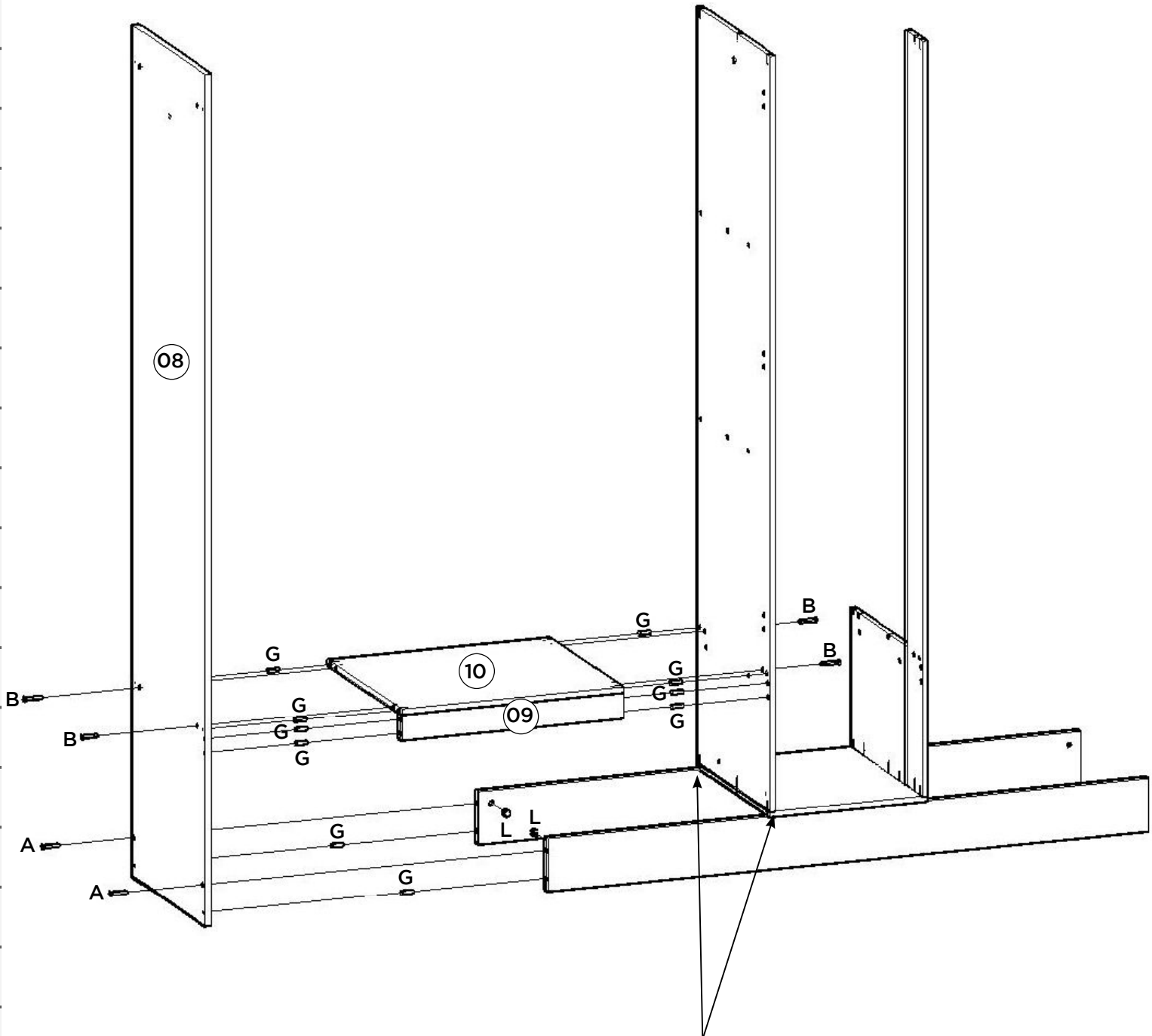

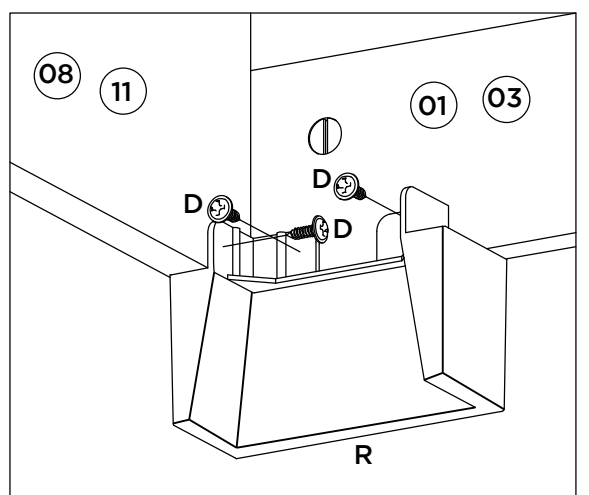
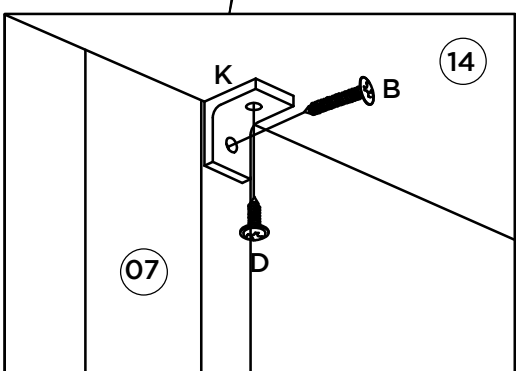
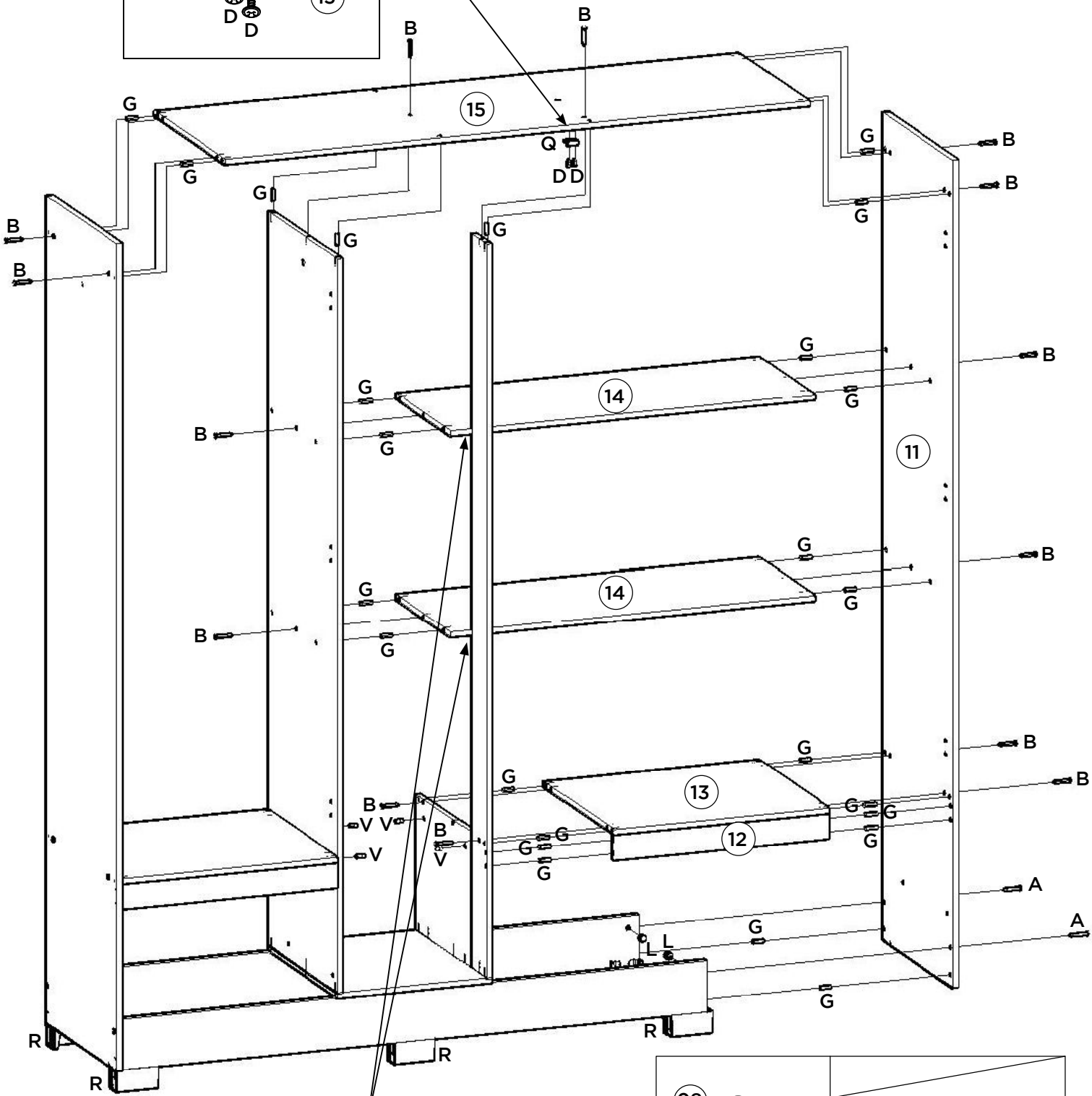
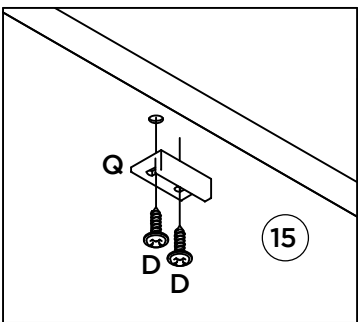

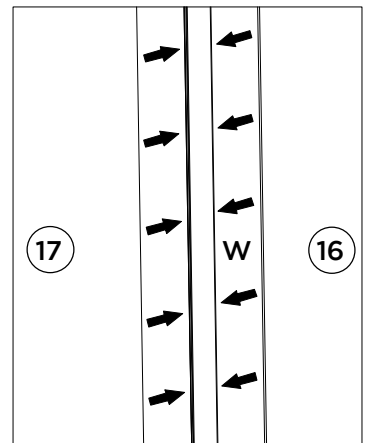
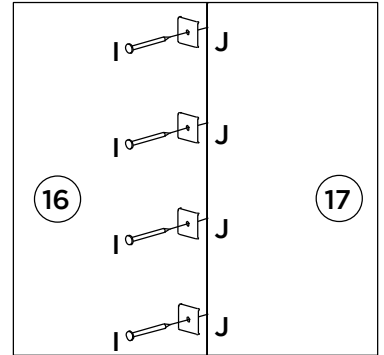
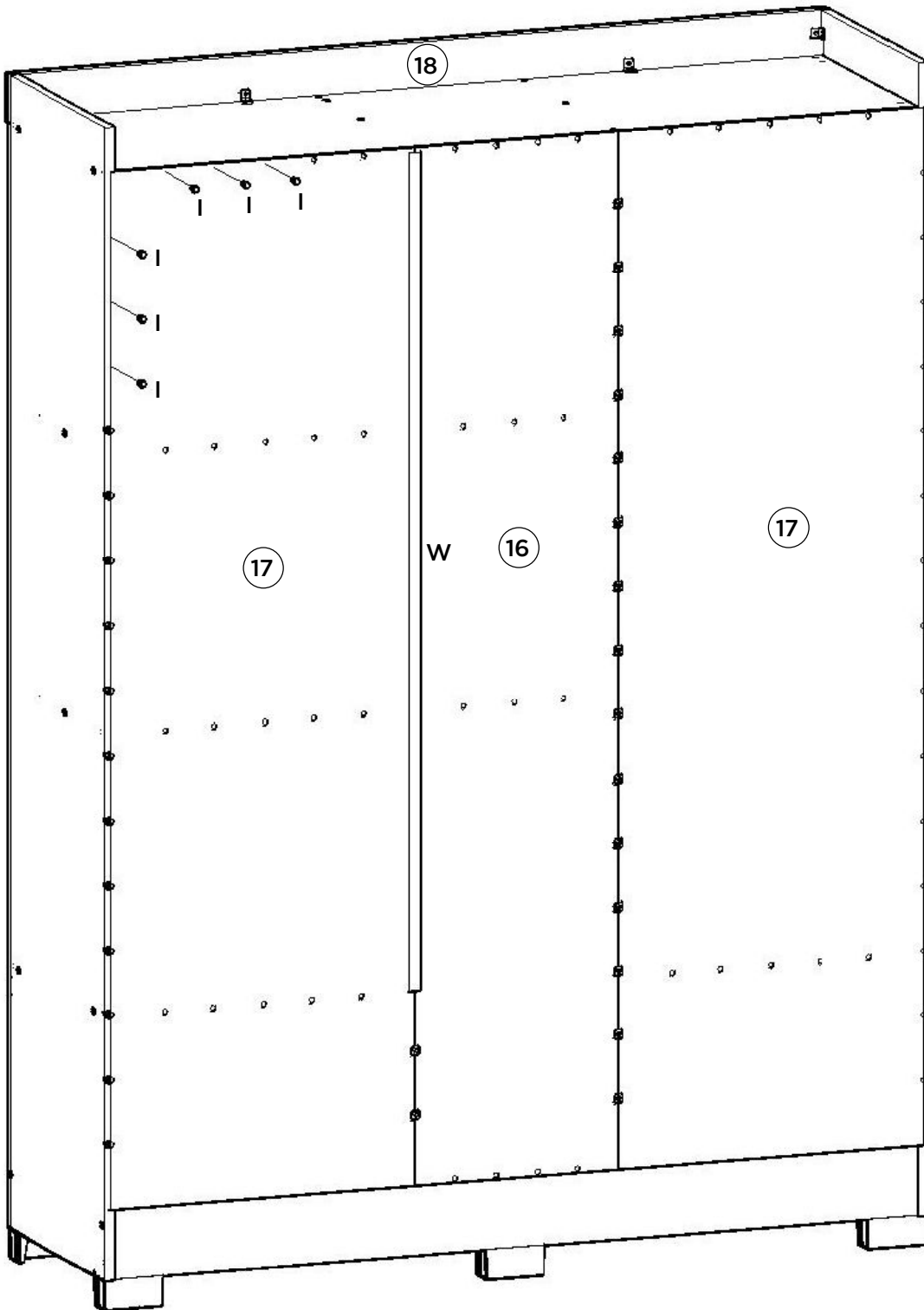
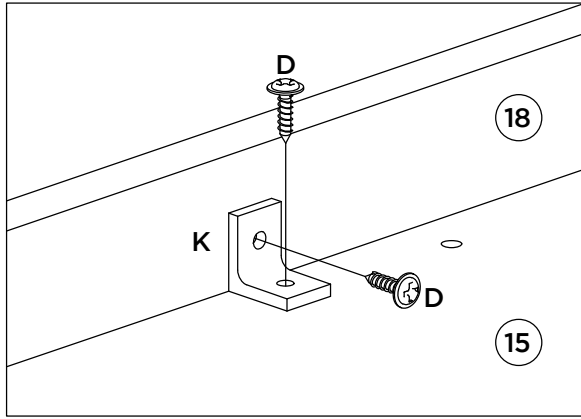

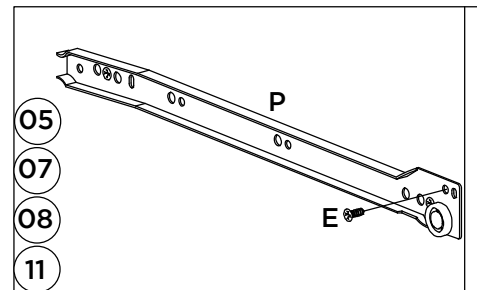
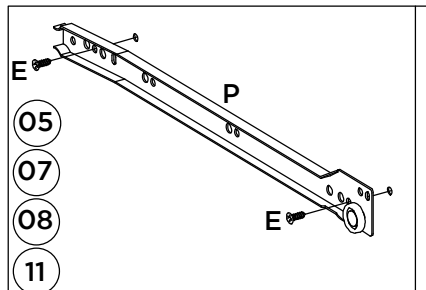
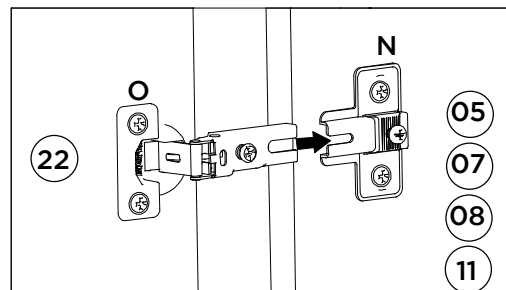
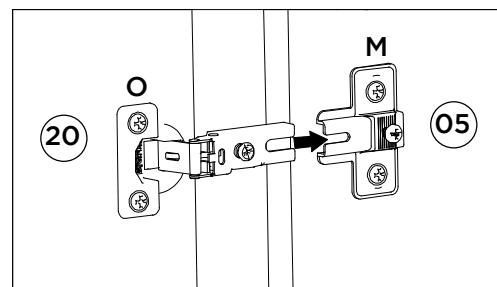
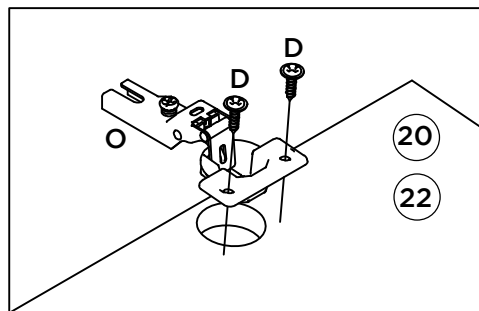
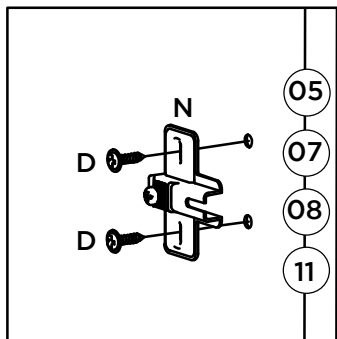
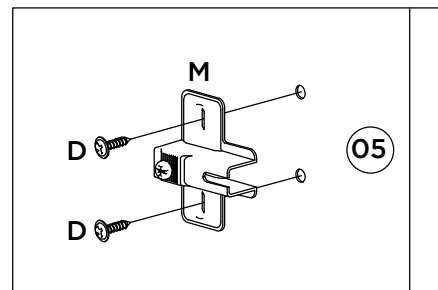
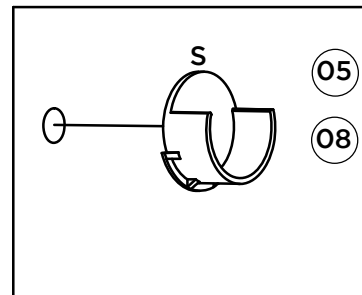
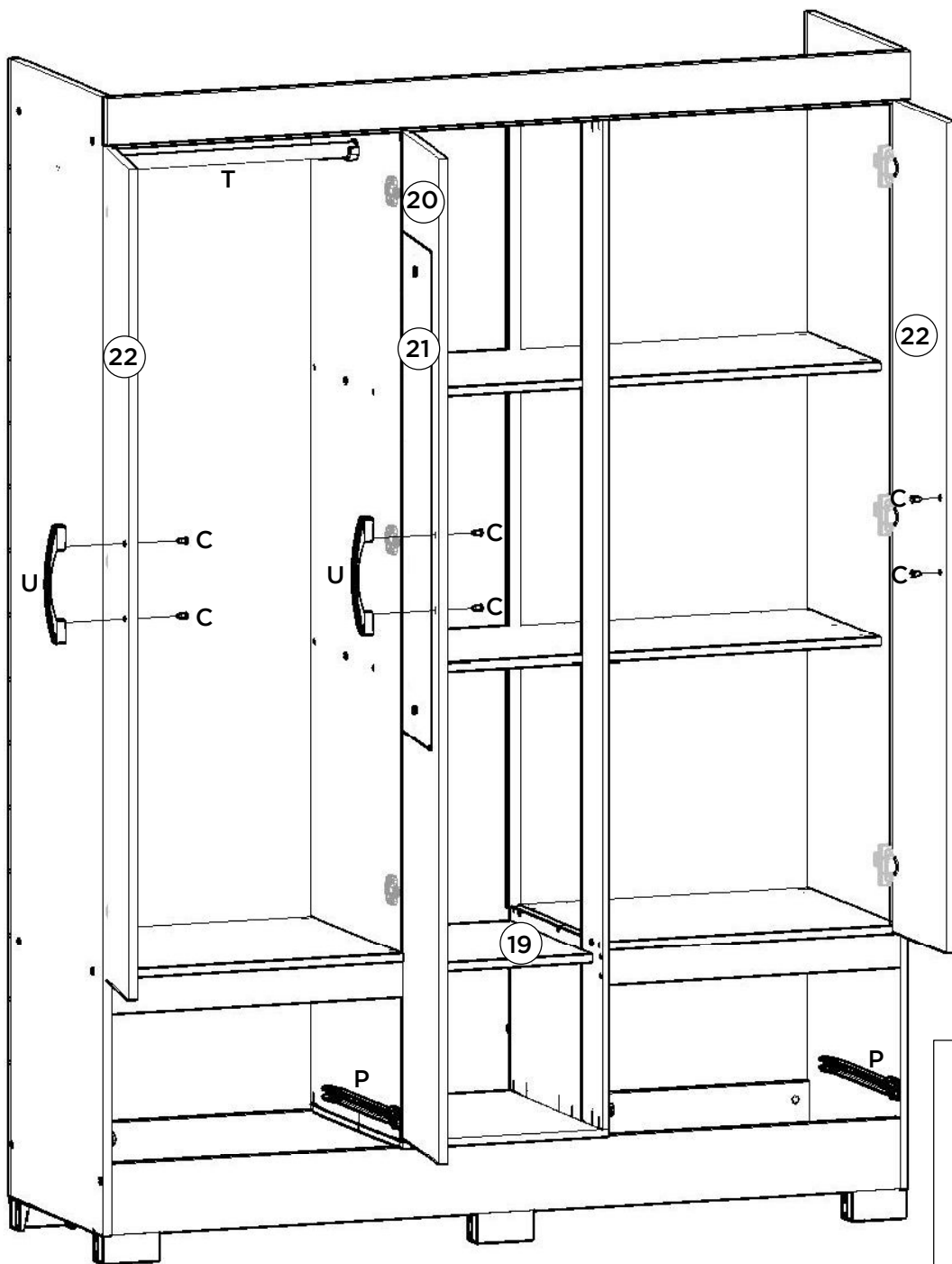

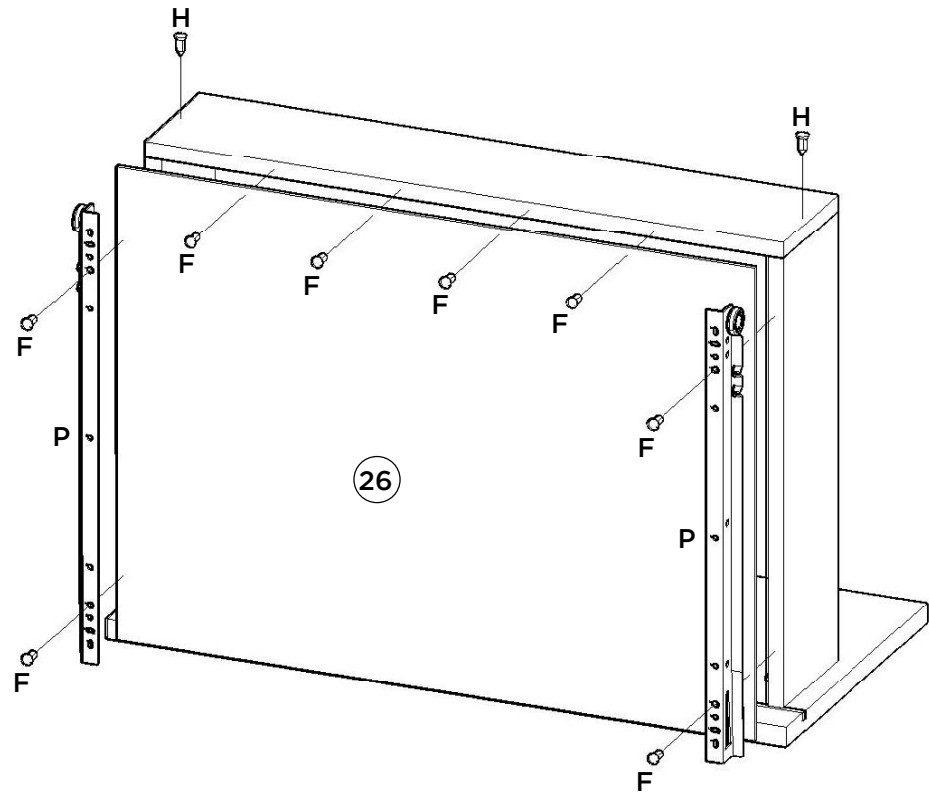
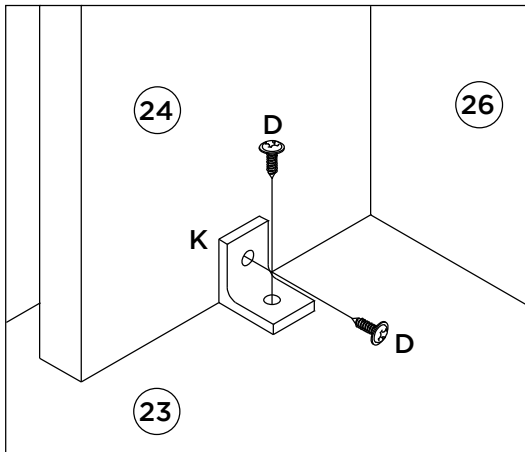
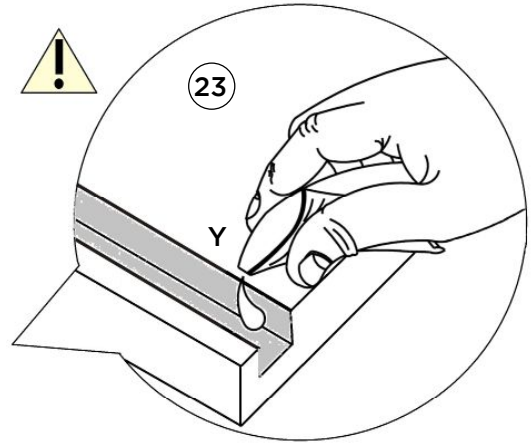
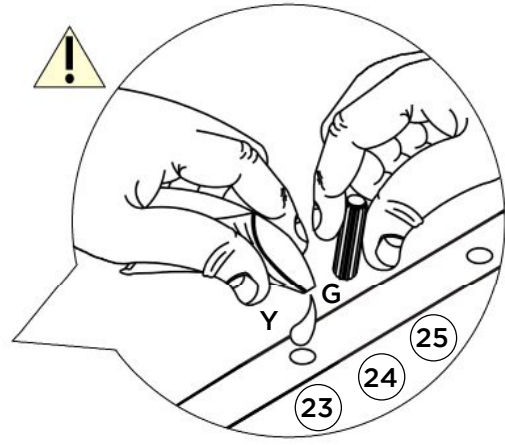
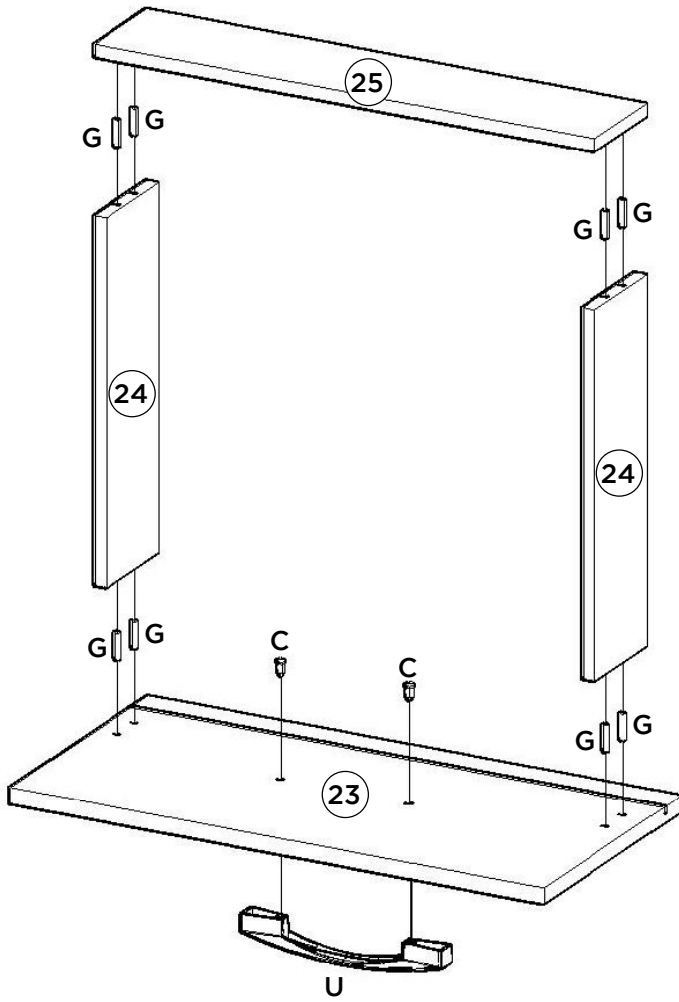





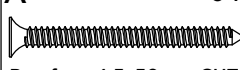
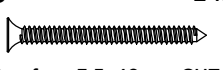
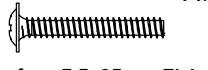
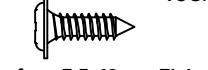
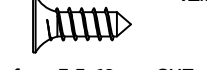
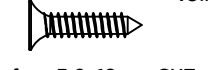

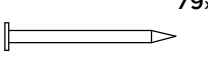
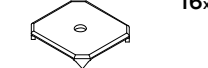







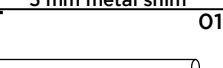

Item	Caixa Caja Box	Qtd Ctd Qty	Descrição Descripción Description	Medidas (mm) Dimensions (mm) Size (measurements) (mm)
01	1/2	01	Rodapé Frontal Pie de página Front Footer	1424x120x12
02	1/2	01	Travessa do Rodapé Carril pie Baseboard crosspiece	415x120x12
03	1/2	01	Rodapé Traseiro pie de página trasera Rear Footer	1424x120x12
04	1/2	01	Base Base Base	445x374x12
05	1/2	01	Divisão esquerda División izquierda Left Division	1730x445x12
06	1/2	01	Divisão gaveta direita División cajón derecho Right drawer partition	350x320x12
07	1/2	01	Pilastra Pilas Pilaster	1730x95x12
08	1/2	01	Lateral esquerda Lateral izquierda Left side	1950x445x15
09=12	2/2	01	Travessa Frontal Travessa Frontal Front cross member	525x60x12
10=13	1/2	01	Tampo da Gaveta Tablero de la Cajón Drawer Top	525x445x12
11	1/2	01	Lateral direita Lateral derecha Right side	1950x445x15
12=09	2/2	01	Travessa Frontal Travessa Frontal Front cross member	525x60x12
13=10	1/2	01	Tampo da Gaveta Tablero de la Cajón Drawer Top	525x445x12
14	1/2	02	Prateleira Maior Estantería Mayor Largest Shelf	887x350x12
15	1/2	01	Tampo Superior Tapa superior Top panel	1424x445x12
16	1/2	01	Fundo Fondo Bottom	1754x362x3
17	2/2	02	Fundo Maior Fondo Mayor Greater Fund	1754x538x3
18	2/2	01	Chapéu Sombrero Hat	1452x80x15
19	1/2	01	Prateleira Central Estantería central Central Shelf	400x350x12
20	2/2	01	Porta Espelho Puerta Espejo Mirror Door	1722x344x15
21	2/2	01	Espelho com furo Espejo con orificio Mirror with hole	850x220x3
22	2/2	04	Porta Puerta Door	1423x265x15
23	2/2	02	Frente de gaveta Frente de cajón Front of drawer	533x260x15
24	1/2	04	Lado de gaveta Lado del cajón Side of drawer	350x100x12
25	1/2	02	Ripa de trás Malla detrás Rear lath	500x100x12
26	1/2	02	Fundo de gaveta Fondo de cajón Drawer bottom	499x367x3

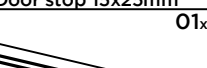
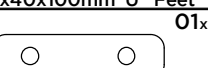
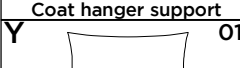
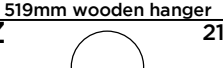
Ferragens | Herrajes | Hardware

A  Parafuso 4,5x50mm CHT. Tornillo 4,5x50mm CHT. Screw 4,5x50mm CHT.	B  Parafuso 3,5x40mm CHT. Tornillo 3,5x40mm CHT. Screw 3,5x40mm CHT.	C  Parafuso 3,5x25mm FLA. Tornillo 3,5x25mm FLA. Screw 3,5x25mm FLA.	D  Parafuso 3,5x12mm FLA. Tornillo 3,5x12mm FLA. Screw 3,5x12mm FLA.	E  Parafuso 3,5x12mm CHT. Tornillo 3,5x12mm CHT. Screw 3,5x12mm CHT.	F  Parafuso 3,0x16mm CHT. Tornillo 3,0x16mm CHT. Screw 3,0x16mm CHT.
G  Cavilha 5x25mm Cinta 5x25mm Dowel 5x25mm	H  Prego 12x12mm Anelado Clavo 12x12mm Anillado Ringed Nails 12x12mm	I  Prego 10x10mm Clavo 10x10mm Nail 10x10mm	J  Fixador de fundos Fijador de fondos Bottom fixer	K  Cantoneira plástica Cantonera plástica Plastic angle brackets	L  Porca Cilíndrica Tuerca cilíndrica Cylindrical nut
M  Calço metal 12mm Calzado metálico 12mm 12 mm metal shim	N  Calço metal 5mm Calzado metálico 5mm 5 mm metal shim	O  Dobradiça metal 26mm Bisagra de metal 26mm 26mm metal hinge	P  Corrediça metal 350mm Corredera de metal 350mm Sliding metal 350mm	Q  Batente 15x25mm Aldaba 15x25mm Door stop 15x25mm	R  Pé "U" 50x40x100mm Pie "U" 50x40x100mm 50x40x100mm"U" Feet
S  Suporte cabideiro Soporte de percha Coat hanger support	T  Cabideiro Madeira 519mm Cabezal Madera 519mm 519mm wooden hanger	U  Puxador Indonésia 128mm Tirador Indonésia 128mm 128mm Indonesia handle	V  Suporte prateleira Soporte estante Shelf Support	W  Perfil "I" 1418mm Perfil "I" 1418mm Profile "I" 1418mm	X  Suporte de Metal Soporte de Metal Metal stands
Y  Sachê de cola Bolsa de pegamento Glue bag	Z  Adesivo tapa parafuso 10mm Adhesivo tapón de tornillo 10mm Bolt cover adhesive 10mm	AA  Etiqueta resinada Briz Etiqueta resinada Briz Briz resin label			