

**Roupeiro 06 Portas 03 Gavetas | Armario 06 puertas y 03 cajones |
Wardrobe 06 Doors 03 Drawers**

- B23-10 - Branco
- B23-108 - Duna/OFF White
- B23-127 - Nature/OFF White
- B23-130 - Castanho HP II
- B23-166 - Nature/Cinza

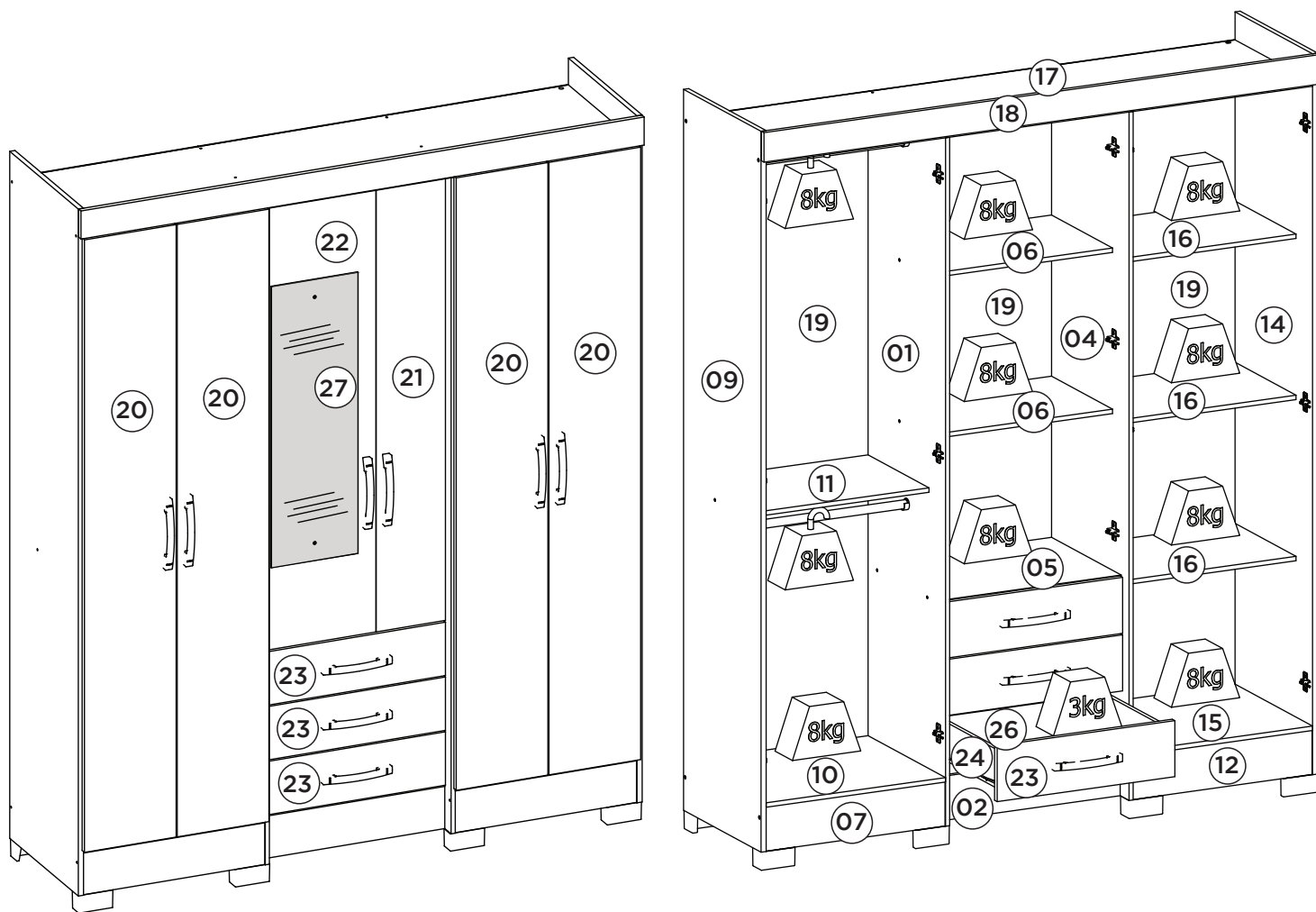

Requisitos para montagem
Requisitos para la montaje
Assembly Requirements

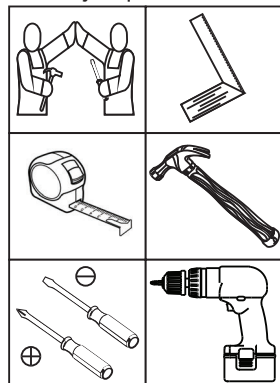

Imagens meramente ilustrativas,
não acompanha o produto.
Imágenes ilustrativas, no incluidas
con el producto.
Illustrative images, not included
with the product.

**Pesos máximos recomendados com carga distribuída
Peso máximo recomendado con la carga distribuida
Recommended maximum weights with evenly distributed.**

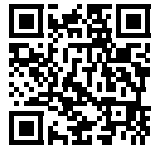
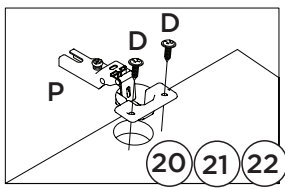
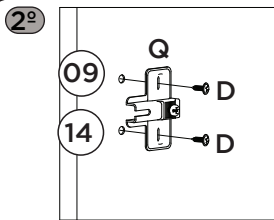

Video: Instalar e regular Dobradiças

Video: Instale y ajuste las bisagras

Video: Install and adjust hinges

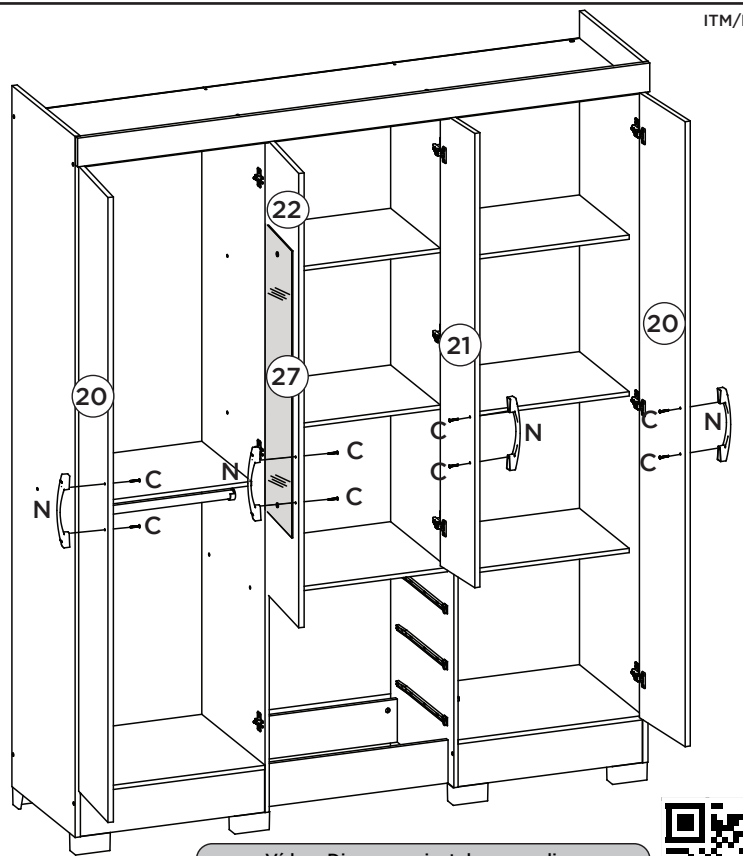
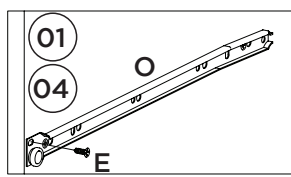
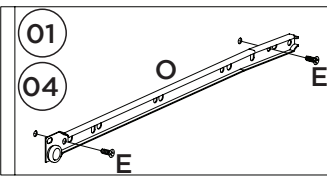
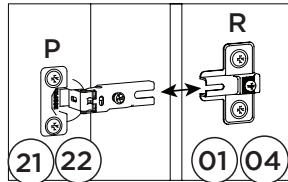
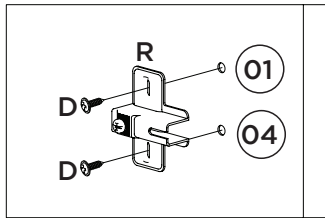
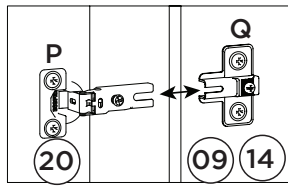

Video: Dicas para instalar corredeira

Video: consejos para instalar la diapositiva

Video: Tips for installing slide

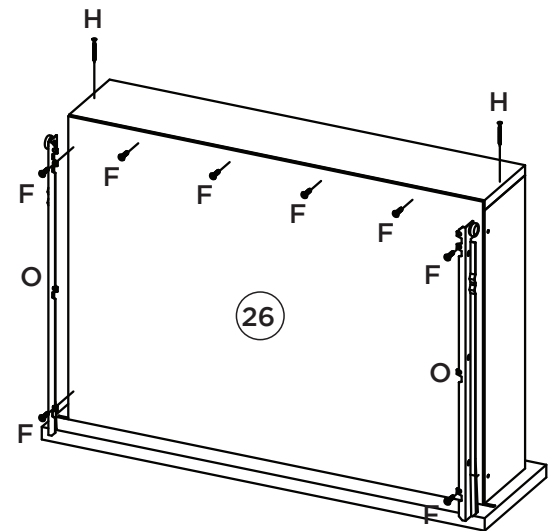
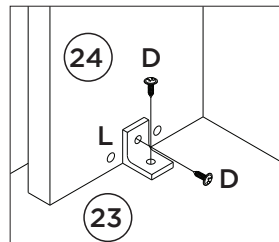
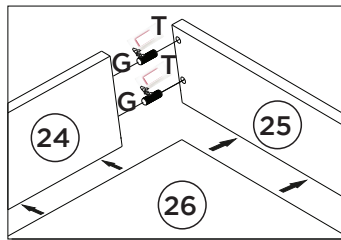
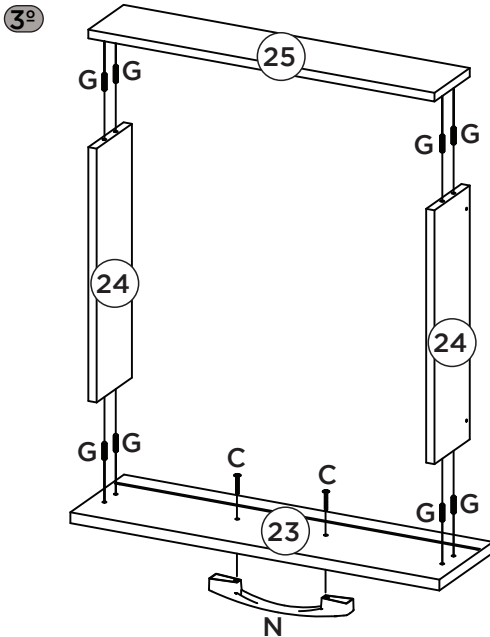

AVISO

Para limpeza de seu móvel, use uma flanela seca ou umedecida, e não utilize produtos químicos que possam danificar seu produto.

SISTEMA DE MONTAGEM

O sistema de montagem dos produtos, funciona de acordo com a ordem crescente dos números indicados no desenho. Ex: 01, 02, 03, 04... até a conclusão da montagem.

ASSISTÊNCIA TÉCNICA

Para solicitação de Assistência Técnica você consumidor deverá entrar em contato com o Lojista o qual você realizou a compra deste produto e solicitar a assistência técnica das peças avariadas. A garantia abrange todas as peças, partes e componentes que eventualmente venham apresentar defeito de fabricação no prazo de 03 (três) meses, contando a partir da entrega do produto ao consumidor, mediante nota fiscal de compra. Se houver qualquer alteração na estrutura do produto ou ocorrer defeito por negligência do montador/consumidor em relação a instrução de montagem e manuseio, não será fornecido assistência técnica gratuita.

ADVERTENCIA

Para limpieza de su móbil, use una franela seca o húmeda, y no utilice productos químicos que puedan dañar su producto.

SISTEMA DE MONTAJE

El sistema de montaje de los productos funciona de acuerdo con el orden creciente de los números indicados en el dibujo. Ej.: 01, 02, 03, 04... hasta la conclusión del montaje.

ASISTENCIA TÉCNICA

Para solicitar Asistencia Técnica, el consumidor debe comunicarse con el Comercio que usted realizó la compra de este producto y solicita asistencia técnica para las partes dañadas. La garantía cubre todas las partes, piezas y componentes que eventualmente puedan presentar defecto de fabricación en el plazo de 03 (tres) meses, contados a partir de la entrega del producto al consumidor, mediante factura de compra. Si se produce algún cambio en la estructura del producto o se produce un defecto por negligencia del montador/consumidor en relación con las instrucciones de montaje y manipulación, no se prestará asistencia técnica gratuita.

NOTICE

To clean your furniture, use a dry or wet cloth, and do not use chemicals that may damage your product.

ASSEMBLY SYSTEM

The products' assembly system works according to the increasing order of the indicated numbers. For example: 01, 02, 03, 04 ... to the end of the assembly.













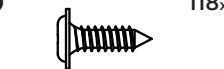



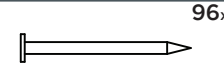



TECHNICAL ASSISTANCE

To request Technical Assistance, the consumer must contact the retailer from whom you purchased this product and request technical assistance for the damaged parts. The warranty covers all parts, parts and components that may eventually present a manufacturing defect within a period of 03 (three) months, counting from the delivery of the product to the consumer, by means of a purchase invoice. If there is any change in the structure of the product or defect occurs due to negligence of the assembler/consumer in relation to the assembly and handling instruction, free technical assistance will not be provided.

LISTA DE PEÇAS | LISTA DE PIEZAS | LIST OF PARTS

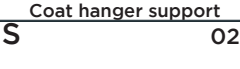
Item	Caixa Caja Box	Qtd Ctd Qty	Descrição Descripción Description	Medidas (mm) Dimensions (mm) Size (measurements) (mm)
01	1/2	01	Divisão Esquerda División izquierdo Left Division	1867x445x12
02=07=12	1/2	01	Rodapé Frontal Rodapié Frontal Front baseboard	525x120x12
03=08=13	1/2	01	Rodapé Traseiro Rodapié trasero Rear baseboard	525x120x12
04	1/2	01	Divisão direita División derecha Right division	1867x445x12
05	1/2	01	Tampo da Cômoda Cubierta de la cómoda Top of the dresser	525x400x12
06=11=16	1/2	02	Prateleira Estante Shelf	525x350x12
07=02=12	1/2	01	Rodapé Frontal Rodapié Frontal Front baseboard	525x120x12
08=03=13	1/2	01	Rodapé Traseiro Rodapié trasero Rear baseboard	525x120x12
09	1/2	01	Lateral esquerda Lateral izquierda Left side	1955x445x12
10=15	1/2	01	Chão Suelo Ground	525x445x12
11=06=16	1/2	01	Prateleira Estante Shelf	525x350x12
12=02=07	1/2	01	Rodapé Frontal Rodapié Frontal Front baseboard	525x120x12
13=08=03	1/2	01	Rodapé Traseiro Rodapié trasero Rear baseboard	525x120x12
14	1/2	01	Lateral direita Lateral derecha Right side	1955x445x12
15=10	1/2	01	Chão Suelo Ground	525x445x12
16=06=11	1/2	03	Prateleira Estante Shelf	525x350x12
17	2/2	01	Tampo superior Tapa superior top panel	1599x445x12
18	2/2	01	Chapéu Sombrero Hat	1621x80x15
19	2/2	03	Fundo Fondo Bottom	1759x538x3
20	2/2	04	Porta Lateral Puerta lateral Side door	1743x265x15
21	2/2	01	Porta Estreita Puerta estrecho Narrow door	1267x200x15
22	2/2	01	Porta Menor Espelho Puerta baja espejo Small Mirror Door	1267x318x15
23	2/2	03	Frente de gaveta Frente de cajón Front of drawer	519x152x15
24	2/2	06	Lado de gaveta Lado del cajón Side of drawer	350x100x12
25	1/2	03	Ripa de trás Malla detrás Rear lath	500x100x12
26	2/2	03	Fundo de gaveta recortado Fondo del cajón recortado Cropped drawer bottom	499x367x3
27	2/2	01	Espelho Espejo Mirror	850x220x3

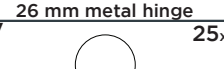
FERRAGENS | HERRAJES | HARDWARE

A  Parafuso 4,5x50mm CHT. Tornillo 4,5x50mm CHT. Screw 4,5x50mm CHT.	16x	B  Parafuso 3,5x40mm CHT. Tornillo 3,5x40mm CHT. Screw 3,5x40mm CHT.	18x	C  Parafuso 3,5x25mm FLA. Tornillo 3,5x25mm FLA. Screw 3,5x25mm FLA.	18x	D  Parafuso 3,5x12mm FLA. Tornillo 3,5x12mm FLA. Screw 3,5x12mm FLA.	118x	E  Parafuso 3,5x12mm CHT. Tornillo 3,5x12mm CHT. Screw 3,5x12mm CHT.	18x	F  Parafuso 3,0x16mm CHT. Tornillo 3,0x16mm CHT. Screw 3,0x16mm CHT.	24x
G  Cavilha 5x25mm Cinta 5x25mm Dowel 5x25mm	78x	H  Prego 12x12mm Anelado Clavo 12x12mm Anillado Ringed Nails 12x12mm	08x	I  Prego 10x10mm Clavo 10x10mm Nail 10x10mm	96x	J  Fixador de fundos Fijador de fondos Bottom fixer	24x	K  Porca cilíndrica Tuerca cilíndrica Cylindrical nut	16x	L  Cantoneira plástica Cantonera plástica Plastic angle brackets	10x
M  Suporte cabideiro Soporte de percha Coat hanger support	04x	N  Puxador Indonésia 128mm Tirador Indonésia 128mm 128mm Indonésia Handle	09x	O  Corrediça metal 350mm Corredera de metal 350mm Sliding metal 350mm	03x	P  Dobradiça metal 26mm Bisagra de metal 26mm 26 mm metal hinge	18x	Q  Calço metal 5mm Calzado metálico 5mm 5 mm metal shim	12x	R  Calço metal 12mm Calzado metálico 12mm 12 mm metal shim	06x
S  Cabideiro Madeira 519mm Cabezal Madera 519mm 519mm wooden hanger	02x	T  Sachê de cola Bolsa de pegamento Glue bag	02x	U  Pé "U" 50x40x100mm Pie "U" 50x40x100mm 50x40x100mm "U" feet	08x	V  Adesivo tapa parafuso 10mm Adhesivo tapón de tornillo 10mm Bolt cover adhesive 10mm	25x	W  Batente 15x25mm Parada 15x25mm 15x25mm stop	01x	X  Etiqueta resinada Briz Etiqueta resinada Briz Briz resin label	01x