

# Roupeiro / Ropero / Wardrobe

## MONTANA

### BC-2198

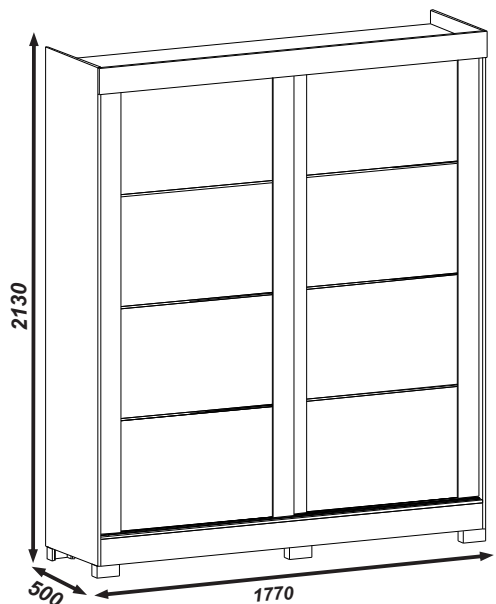

#### Instruções para a montagem do produto:

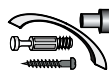

**Separe as peças e acessórios de maneira organizada.**

Separate the parts and accessories in an organized way.  
Separe las piezas y accesorios de forma organizada



**Forrar o chão com o papelão das embalagens.**

Cover the floor with the cardboard from the pack.  
Cubre el suelo con el cartón de los bultos.



**É necessário duas pessoas para montar o produto.**

It's necessary two people to assembly the product.  
Se requiere dos personas para montar el producto.

**Ferramentas necessárias**(não fornecidas)

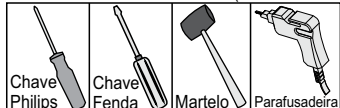

Lote: 616645

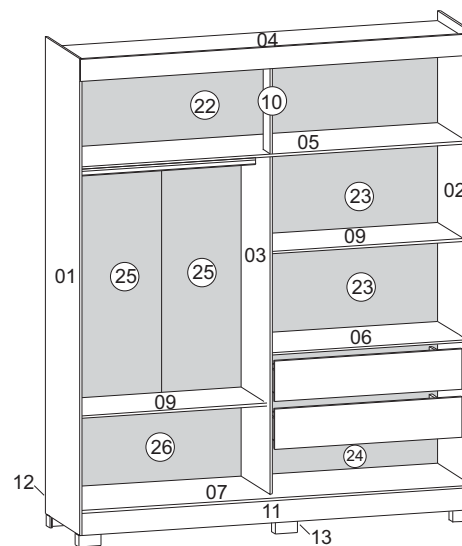
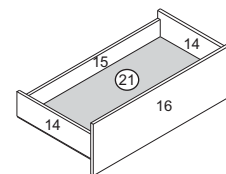
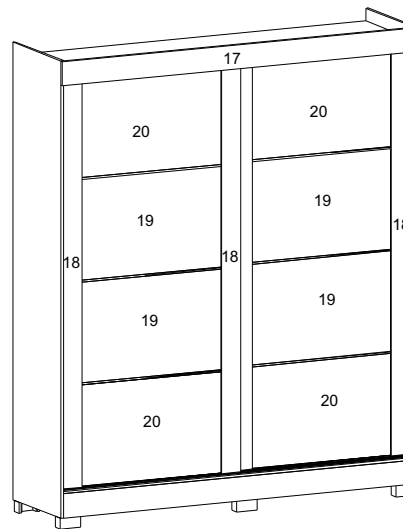

Por

- 01-Lateral Esquerda
- 02-Lateral Direita
- 03-Divisoria
- 04-Tampo Superior
- 05-Tampo Maleiro
- 06-Tampo Central
- 07-Tampo Inferior
- 09-Prateleira (2x)
- 10-Pilastro
- 11-Rodapé Frontal
- 12-Rodapé Traseiro
- 13-Travessa De Rodapé
- 14-Lateral De Gaveta (4x)
- 15-Traseiro De Gaveta (2x)
- 16-Frente De Gaveta (2x)
- 17-Frontal
- 18-Travessa Porta (4x)
- 19-Porta Central (4x)
- 20-Porta Superior E Inferior (4x)
- 21-Fundo De Gaveta (2x)
- 22-Costa Superior
- 23-Costa Central Direita (2x)
- 24-Costa Inferior Direita
- 25-Costa Central Esquerda (2x)
- 26-Costa Inferior Esquerda

Esp

- 01-Lateral Izquierda
- 02-Lateral Derecha
- 03-Division
- 04-Tapa Superior
- 05-Tapa Maleiro
- 06-Tapa Central
- 07-Tapa Inferior
- 09-Estante (2x)
- 10-Pilaster
- 11-Zócalo Frontal
- 12-Zócalo Trasero
- 13-Travesaño Del Zócalo
- 14-Lateral del Cajón (4x)
- 15-Traseiro del Cajón (2x)
- 16-Frente del Cajón (2x)
- 17-Frontal
- 18-Travesaño Puerta (4x)
- 19-Puerta Central (4x)
- 20-Puerta Superior E Inferior (4x)
- 21-Fondo del Cajón (2x)
- 22-Dorso Superior
- 23-Dorso Central Derecha (2x)
- 24-Dorso Inferior Derecha
- 25-Dorso Central Izquierda (2x)
- 26-Dorso Inferior Izquierda

Eno

- 01-Left Side
- 02-Right Side
- 03-Divider
- 04-Upper Top
- 05-Luggage Locker Top
- 06-Central Top
- 07-Lower Top
- 09-Shelf (2x)
- 10-Pilaster
- 11-Front Base Board
- 12-Back Base Board
- 13-Base Board Crossbar
- 14-Drawer Side (4x)
- 15-Drawer Back (2x)
- 16-Drawer Front (2x)
- 17-Front
- 18-Crossbar Door (4x)
- 19-Central Door (4x)
- 20-Lower y top Door(4x)
- 21-Drawer Bottom (2x)
- 22-Upper Back Panel
- 23-Right Central Back Panel (2x)
- 24-Right Lower Back Panel
- 25-Left Central Back Panel (2x)
- 26-Left Lower Back Panel

DIMENSÕES PEÇAS PRONTAS

- 01-2077 X 482 X 12
- 02-2077 X 482 X 12
- 03-1470 X 399 X 12
- 04-1748 X 481 X 12
- 05-1748 X 400 X 12
- 06-868 X 398 X 12
- 07-1748 X 481 X 12
- 09-868 X 360 X 12
- 10-433 X 95 X 12
- 11-1748 X 95 X 15
- 12-1748 X 95 X 15
- 13-433 X 95 X 12
- 14-338 X 95 X 12
- 15-770 X 95 X 12
- 16-838 X 177 X 12
- 17-1773 X 95 X 15
- 18-1899 X 95 X 25
- 19-725 X 453 X 6
- 20-725 X 493 X 6
- 21-792 X 341 X 3
- 22-1764 X 448 X 3
- 23-432 X 882 X 3
- 24-310 X 882 X 3
- 25-1094 X 441 X 3
- 26-392 X 882 X 3

DIMENSIONES DE LAS PEZAS PRONTAS

- 01-2077 X 482 X 12
- 02-2077 X 482 X 12
- 03-1470 X 399 X 12
- 04-1748 X 481 X 12
- 05-1748 X 400 X 12
- 06-868 X 398 X 12
- 07-1748 X 481 X 12
- 09-868 X 360 X 12
- 10-433 X 95 X 12
- 11-1748 X 95 X 15
- 12-1748 X 95 X 15
- 13-433 X 95 X 12
- 14-338 X 95 X 12
- 15-770 X 95 X 12
- 16-838 X 177 X 12
- 17-1773 X 95 X 15
- 18-1899 X 95 X 25
- 19-725 X 453 X 6
- 20-725 X 493 X 6
- 21-792 X 341 X 3
- 22-1764 X 448 X 3
- 23-432 X 882 X 3
- 24-310 X 882 X 3
- 25-1094 X 441 X 3
- 26-392 X 882 X 3

DIMENSIONS READY MODE PARTS

- 01-2077 X 482 X 12
- 02-2077 X 482 X 12
- 03-1470 X 399 X 12
- 04-1748 X 481 X 12
- 05-1748 X 400 X 12
- 06-868 X 398 X 12
- 07-1748 X 481 X 12
- 09-868 X 360 X 12
- 10-433 X 95 X 12
- 11-1748 X 95 X 15
- 12-1748 X 95 X 15
- 13-433 X 95 X 12
- 14-338 X 95 X 12
- 15-770 X 95 X 12
- 16-838 X 177 X 12
- 17-1773 X 95 X 15
- 18-1899 X 95 X 25
- 19-725 X 453 X 6
- 20-725 X 493 X 6
- 21-792 X 341 X 3
- 22-1764 X 448 X 3
- 23-432 X 882 X 3
- 24-310 X 882 X 3
- 25-1094 X 441 X 3
- 26-392 X 882 X 3

### Ferragens/Herraje/Hardware:

Cód	Itens	Quan
330	A Cavilhas 6 x 30 Clavija Bowel	13
0283	B Parafuso 3,5 x 12 c/c Tornillo Screw	96
5159	C Cavilhas 6 x 50 Clavija Bowel	01
0289	D Parafuso 3,5 x 40 c/c Tornillo Screw	54
0296	E Taxa 10 x 7 Clavo 10 x 7 Nail 10 x 7	140
0438	F Cantoneira Esquinera Cantoneira	21
0538	G Porca cilíndrica Tuerca cilíndrica Cylindrical nut	28
0279	H Fixador de costa Fixador de espalda Fix back	35
0744	I Taxa 13 x 15 Clavo 13 x 15 Nail 13 x 15	08
5960	J Distanciador 25mm Espaciador de 25 mm 25mm spacer	08
-----	K Perfil Porta 695 MM Perfil de puerta Door Profile	06
-----	L Tubo Cabideiro oblongo 860 mm canelado Perchero Holding	01
-----	M Perfil 1082 mm Perfil Profile	01
2296	N Suporte cabideiro oblongo canelado Soporte percha Hanger holding	02
0286	P Parafuso 3,5 x 22 c/c Tornillo Screw	16
3153	Q Batente de Silicone 8mm Tope de Silicona Silicone Stop	08
0477	R Cola Pegamento Glue	01
-----	S KIT PÉ U Foot Kit Juego de Pies	06
-----	T Corrediça 300 mm telescópica Rieles Slides	02
4986	V Kit com 2 Guias com Roldana para Tílo Aluminio Kit de 2 Guias con Polea para Teja de Aluminio Kit with 2 Guide with Pulley for Aluminum Tile	02
-----	X Trilho guia inferior alumínio 1747 mm Riel inferior aluminio aluminum lower guide rail	02
-----	Z Trilho guia E plástico 1747 mm Riel plástico E Plastic guide rail E	01

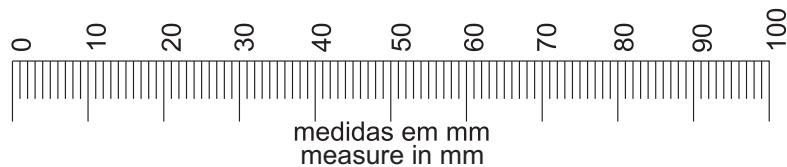

### Montagem da gaveta Armado de los cajones Drawer Assembly

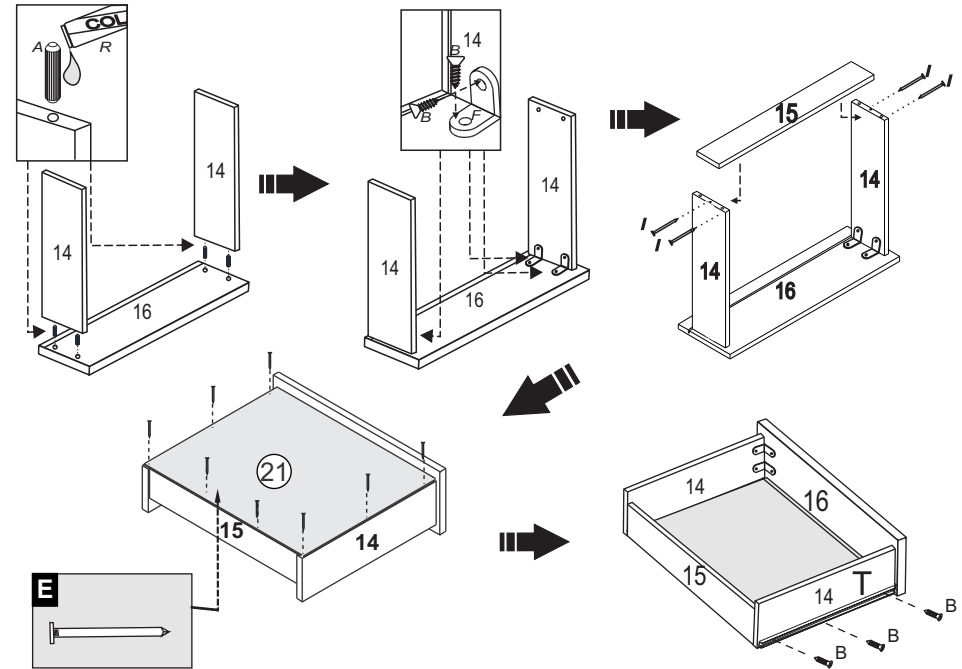

**1º Passo**  
**1º Paso**  
**1º Step**

Atenção! ao parafusar a corrediça  
,cuidar o lado certo.

Atención! al atornillar la corredera,  
cuidar para que esté en el lado correcto

Attention!When screwing the slide,  
take care to do the right side

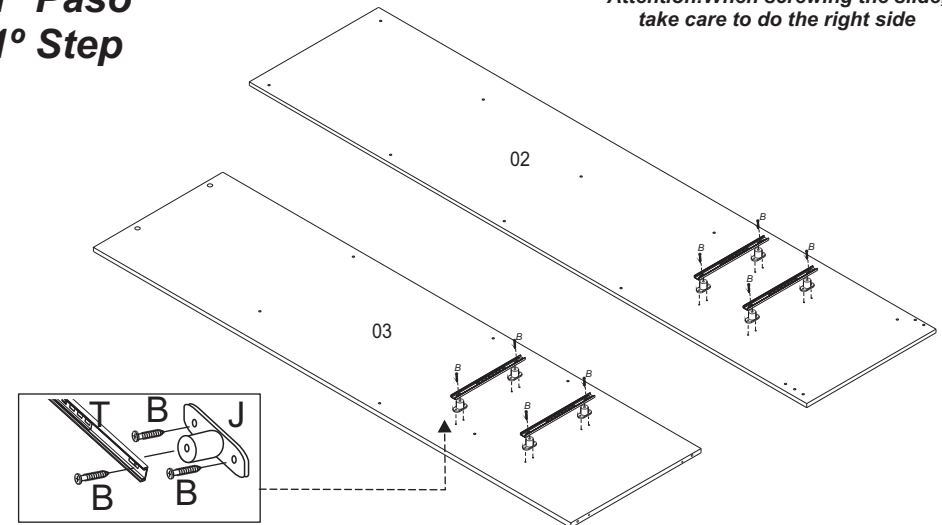

**2º Passo**  
**2º Paso**  
**2º Step**

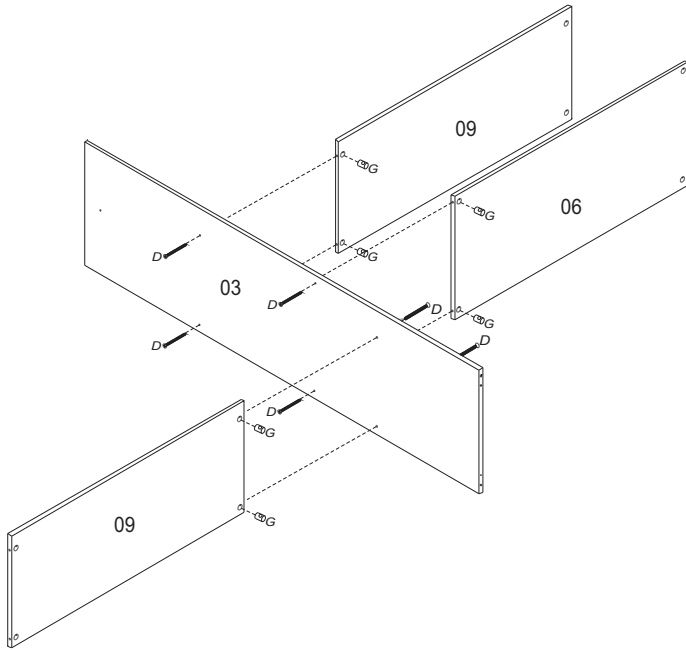

**3º Passo**  
**3º Paso**  
**3º Step**

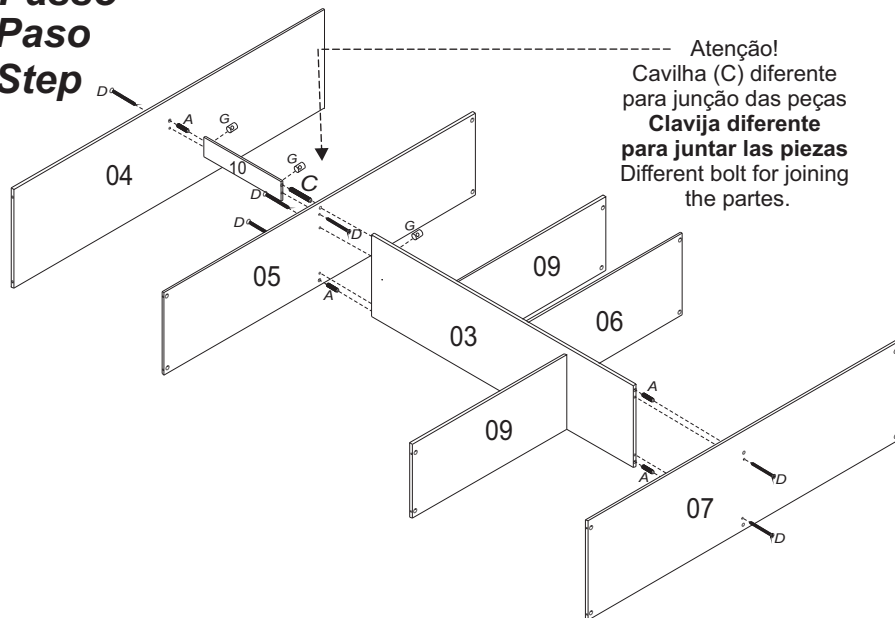

Atenção!  
 Cavilha (C) diferente  
 para junção das peças  
**Clavija diferente**  
 para juntar las piezas  
 Different bolt for joining  
 the partes.

**4º Passo**  
**4º Paso**  
**4º Step**

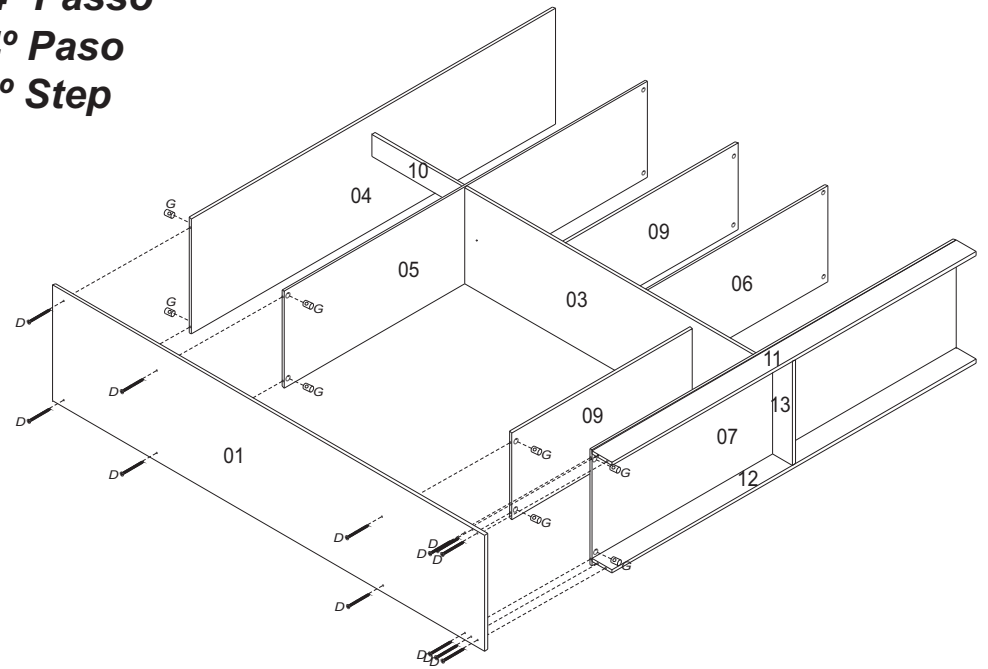

**5º Passo**  
**5º Paso**  
**5º Step**

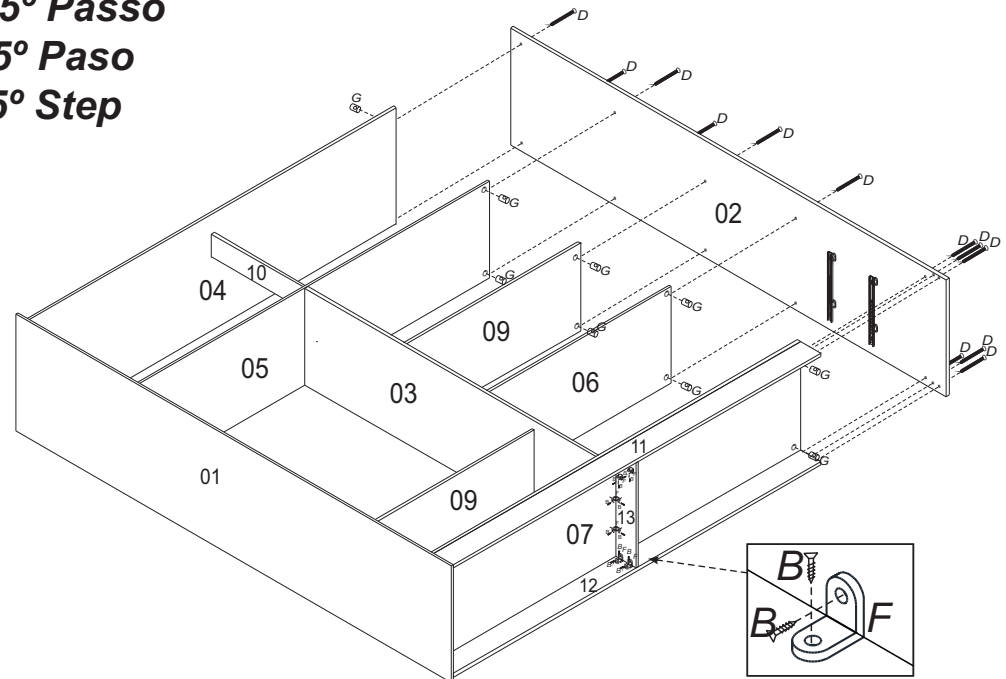

**6° Passo**

**6° Paso**

**6° Step**

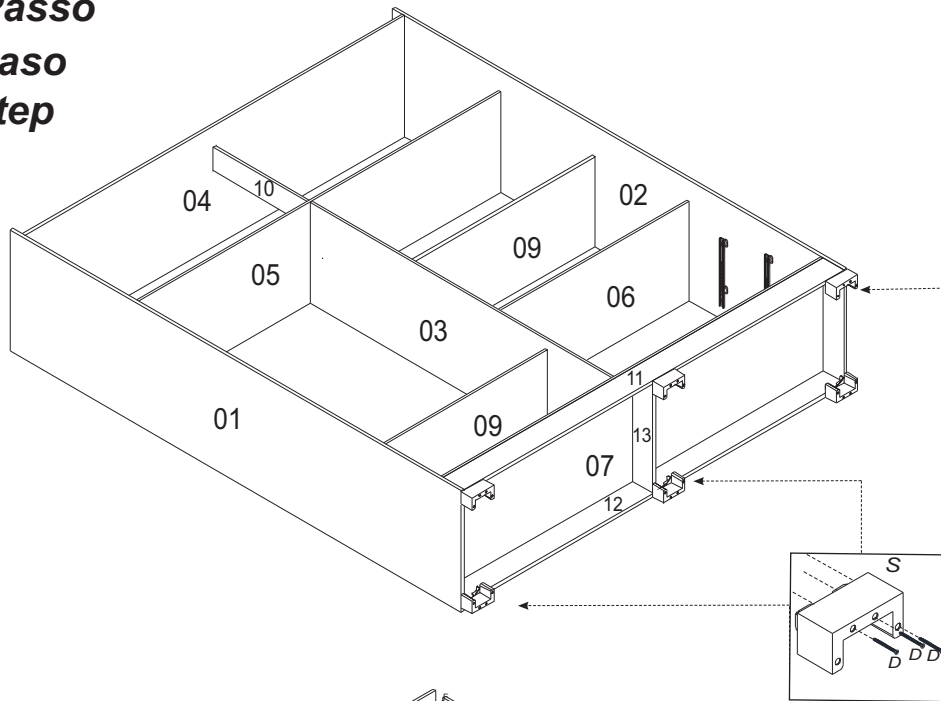

**7° Passo**

**7° Paso**

**7° Step**

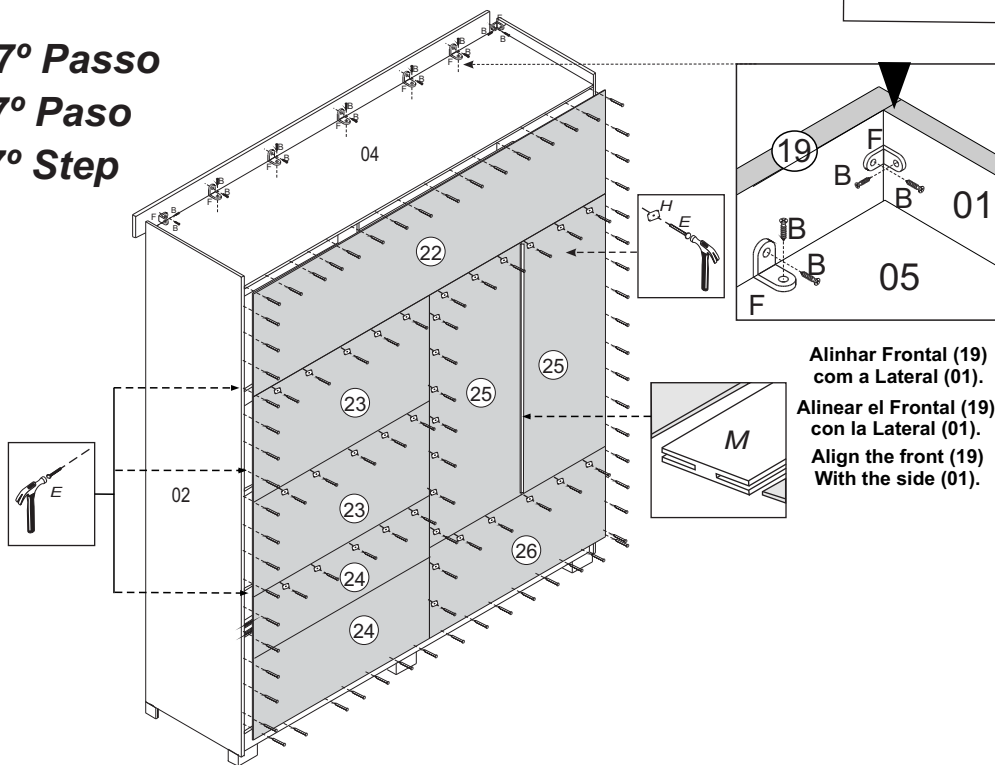

Alinhar Frontal (19)  
com a Lateral (01).

Alinear el Frontal (19)  
con la Lateral (01).

Align the front (19)  
With the side (01).

**8° Passo**

**8° Paso**

**8° Step**

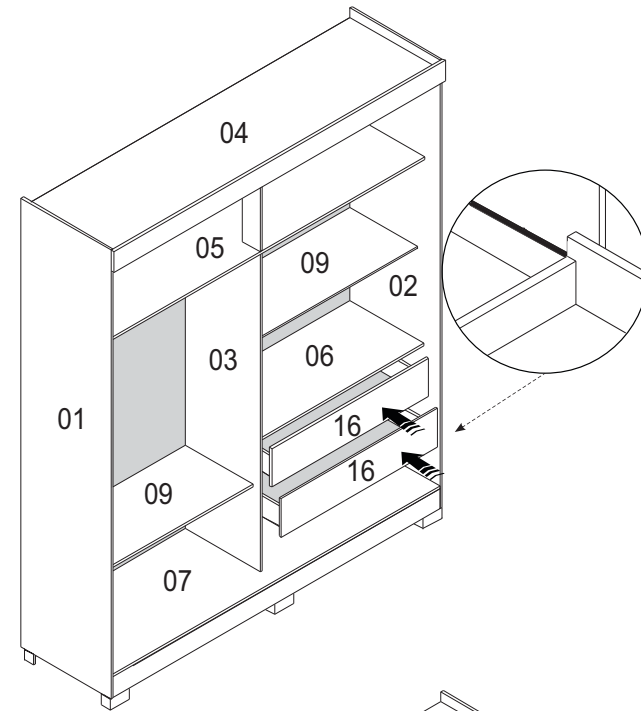

**9° Passo**

**9° Paso**

**9° Step**

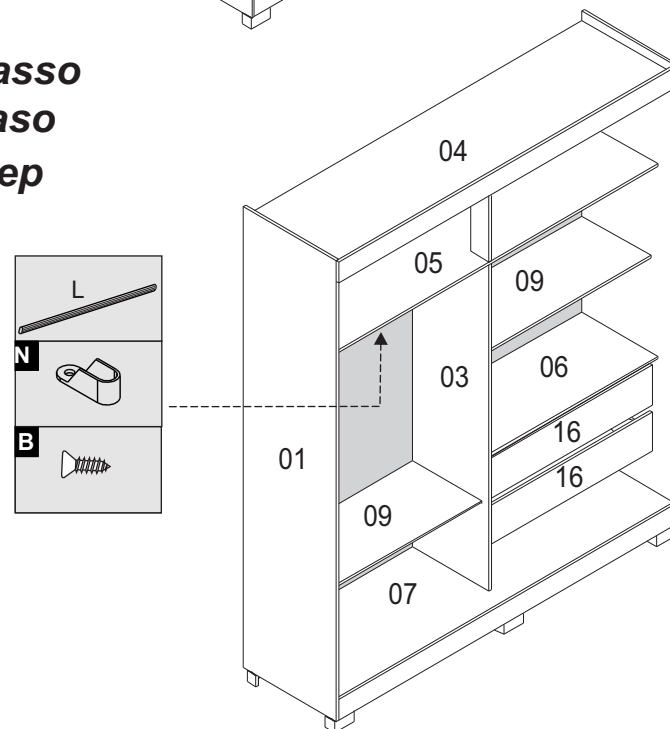

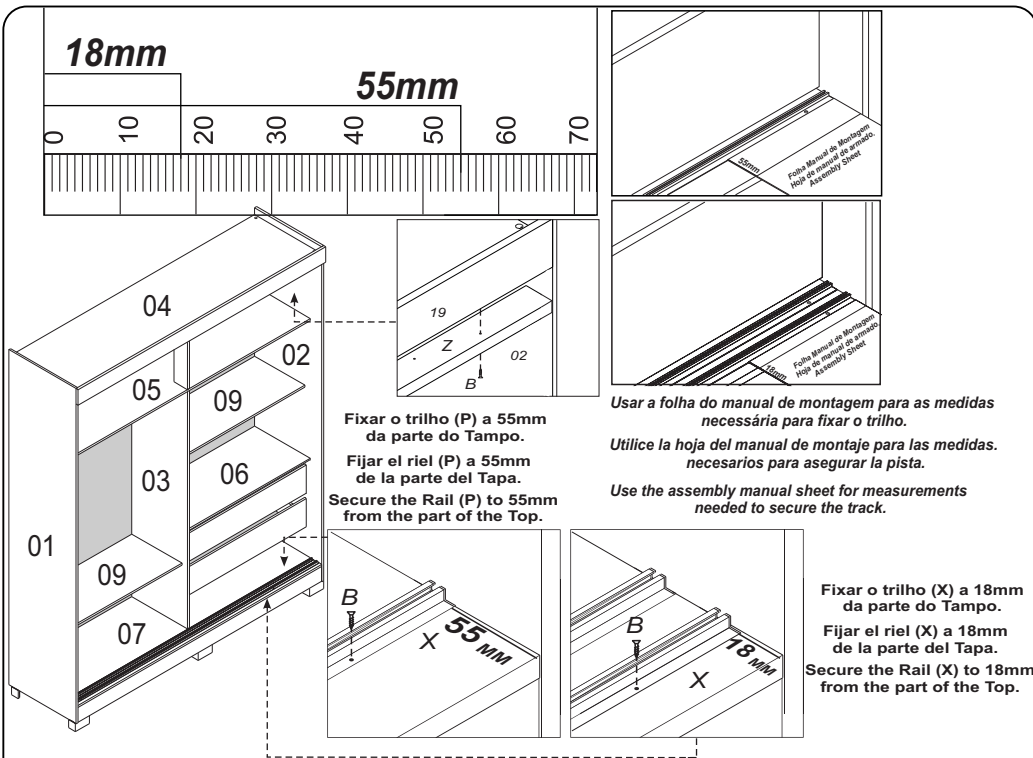

18mm  
55mm

Fixar o trilho (P) a 55mm da parte do Tampo.  
Fijar el riel (P) a 55mm de la parte del Tapa.  
Secure the Rail (P) to 55mm from the part of the Top.

Usar a folha do manual de montagem para as medidas necessária para fixar o trilho.  
Utilice la hoja del manual de montaje para las medidas necesarios para asegurar la pista.  
Use the assembly manual sheet for measurements needed to secure the track.

Fixar o trilho (X) a 18mm da parte do Tampo.  
Fijar el riel (X) a 18mm de la parte del Tapa.  
Secure the Rail (X) to 18mm from the part of the Top.

**11º Passo**  
**11º Paso**  
**11º Step**

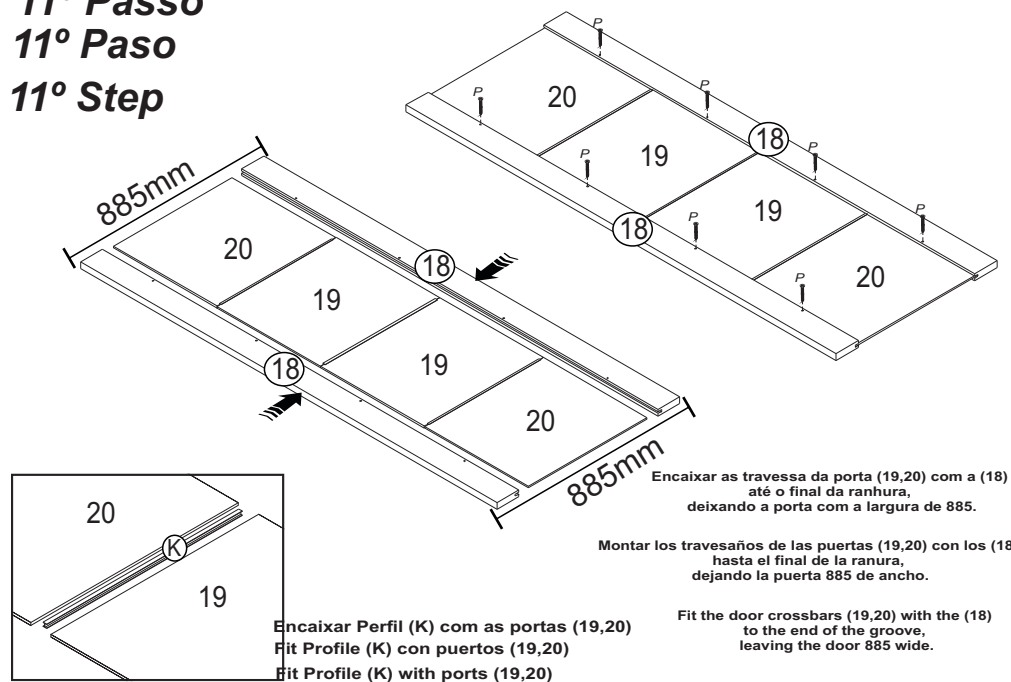

Encaixar as travessa da porta (19,20) com a (18) até o final da ranhura, deixando a porta com a largura de 885.

Montar los travesaños de las puertas (19,20) con los (18) hasta el final de la ranura, dejando la puerta 885 de ancho.

Fit the door crossbars (19,20) with the (18) to the end of the groove, leaving the door 885 wide.

Encaixar Perfil (K) com as portas (19,20)  
Fit Profile (K) con puertos (19,20)  
Fit Profile (K) with ports (19,20)

**12º Passo**  
**12º Paso**  
**12º Step**

Fazer porta Direita e Esquerda na montagem do Kit (R) na parte interna da porta.  
Hacer puerta derecha e izquierda en la el armado del kit (R) en la parte interior de la puerta  
Assembly the right door and left door using the kit (R) inside part of door.

O kit de portas de correr contém os parafusos próprios e somente estes devem ser usados para a fixação do mesmo exceto trilhos.  
El kit de herrajes de las puertas correderas contienen los tornillos propios y solamente estos deben ser usados para la fijación de los rieles

The Sliding door kit contains the screws itself and only this should be used for fixing the same as the Rail.

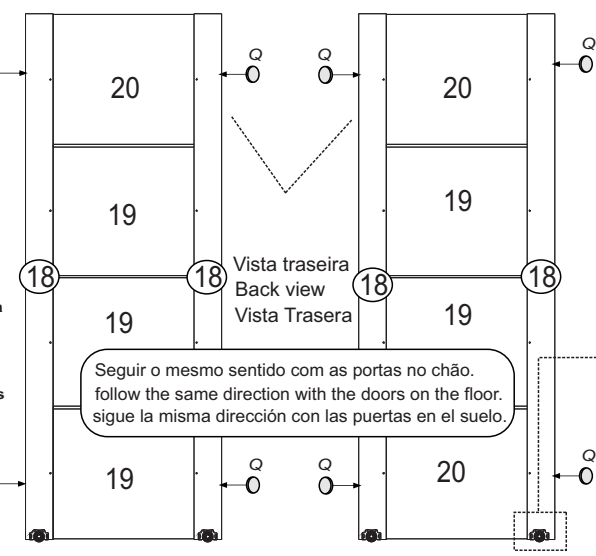

Seguir o mesmo sentido com as portas no chão.  
follow the same direction with the doors on the floor.  
sigue la misma dirección con las puertas en el suelo.

Forrar o chão com o papelão das embalagens.  
Cover the floor with the cardboard from the pack.  
Cubra el suelo con el papelón de los embalajes.

Colocar a 10mm de distancia da porta como mostra figura acima.  
Poner a 10mm de distancia de la puerta conforme indica el imagen arriba.  
Put with 10mm of distance of door as shown in the picture above.

**13º Passo**  
**13º Paso**  
**13º Step**

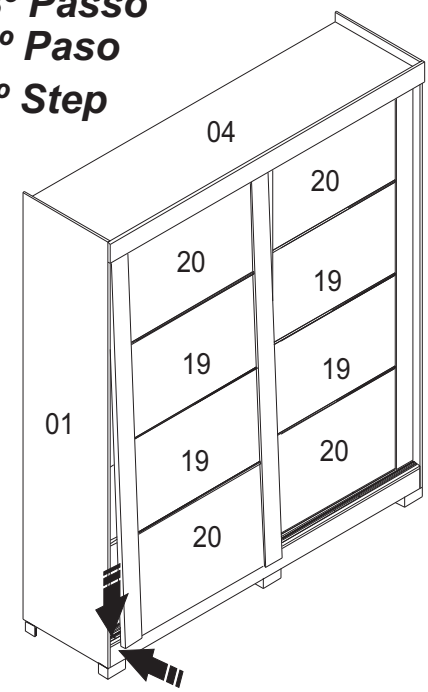

Introduza as portas no trilho superior, em seguida alinhe com o trilho inferior e aloque o rodizio em seu espaço.

Introduzca la puertas en el rieles superior, en seguida alinee con el rieles inferior y asigne en su espacio.

Insert the doors on the top rail, align with the bottom rail and alloque caster in its space.

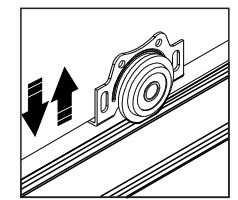

# Manual Adicional para Produtos com Espelho

## ESPELHO/ ESPEJO / MIRROR

### 1º Passo 1º Paso 1º Step

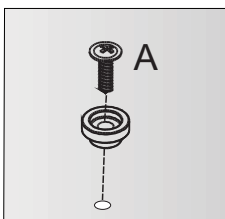
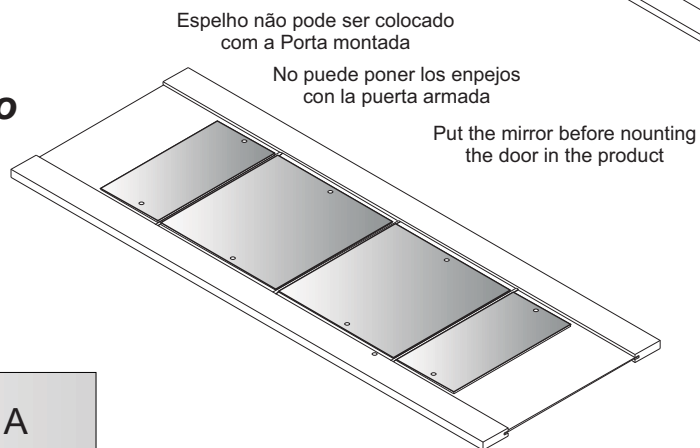

Espejo deve ser alinhado e Parafusar os Kits conforme a imagem

Espejo debe estar alineado y Kits de tornillo según la imagen

Mirror must be align, then, fix the kits as show in the picture

### Ferragens/Herraje/Hardware:

Cód	Itens	Quan
10826	A Kit Fixação Espelho 8 Parafusos 3,5x12 e 8 Aruela	01
8544	B KIT C/2 ESPELHOS 450 X 220 X 3M + 2 ESPELHOS 450 X 440 X 3M	04



Porta deve estar deitada.  
Debe ser limpa com pano seco para retirada do excesso do pó

Puerta debe estar acostada.  
Debe limpiar con un pano seco para eliminar el exceso de polvo.

The door must be lang clean whit dry cloth to remove dust.



### 2º Passo 2º Paso 2º Step

Tamanho Espelho: 450 x 440 mm  
450 X 220 mm

Tamaño del espejo: 450 x 440 mm  
450 X 220 mm

Mirro Size: 450 x 440 mm  
450 X 220 mm

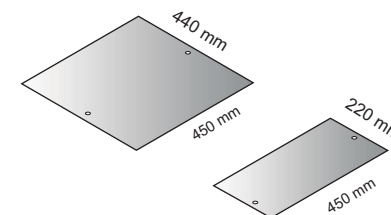

### 4º Passo 4º Paso 4º Step

Colocando Espelhos como na imagem:

Poniedo los espejos conforme la foto

Put the mirror as shown in the picture



Espejo deve estar deitada.  
Debe ser limpa com pano seco para retirada do excesso do pó

Espejo debe estar acostada.  
Debe limpiar con un pano seco para eliminar el exceso de polvo.

The Mirror must be lang clean whit dry cloth to remove dust.

