

Manual de montagem

Instrucciones de montaje Assembly instructions

ARM158BMDP

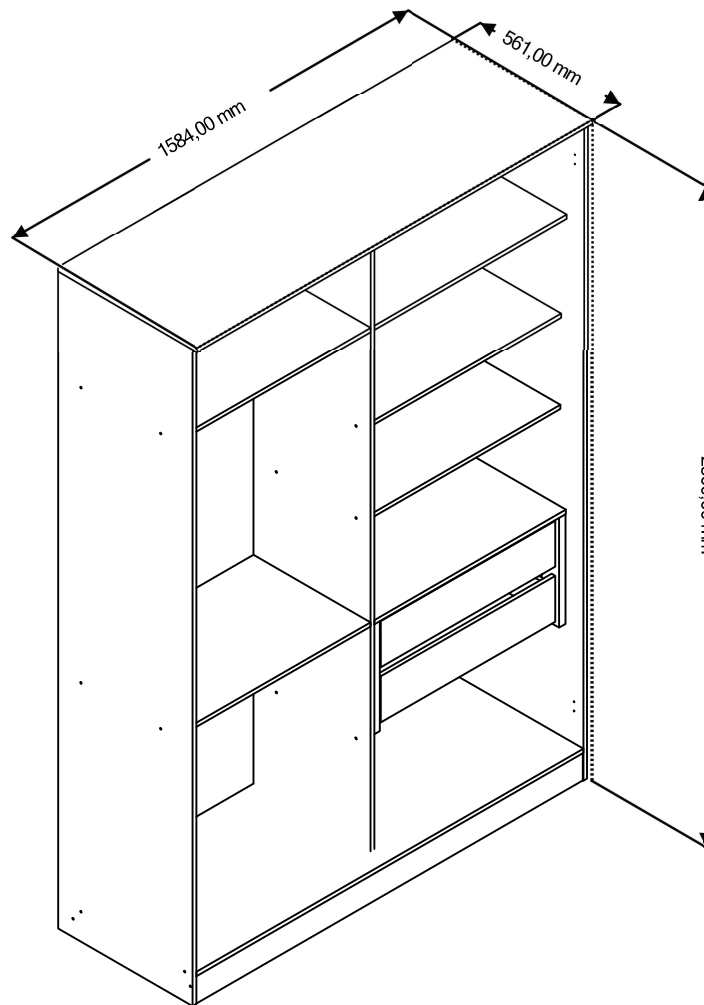

! Imagens meramente ilustrativas !
Imágenes ilustrativas/Images merely illustrative.

Dúvidas? Entre em contato:
Dudas? Ponerse em contacto:
Doubts? Get in touch:
(51) 3635-8839

A montagem deve ser efetuada por 2 pessoas.

El montaje debe ser efectuada por 2 personas.

The assembly must be done by 2 people.

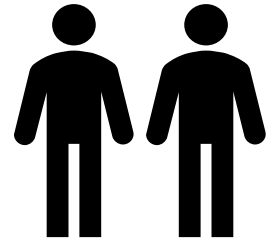

Ferramentas necessárias para montar o móvel.

Herramientas necesarias para armar el mueble.

Tools needed to assemble the furniture.



Dúvidas? Entrar em contato:

Dudas? Ponerse en contacto:

Doubts? Get in touch:

Fone: (51) 3635-8839

www.kappesberg.com.br



Montar o móvel sobre uma superfície limpa e plana.

Armar el mueble sobre una superficie limpia y plana.

Assemble the furniture on a clean, flat surface.

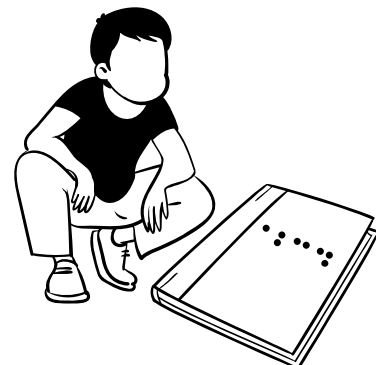

ARM158BMDP

2

**IDENTIFICAÇÃO DAS PEÇAS / IDENTIFICACIÓN DE LAS PIEZAS PARTS
IDENTIFICATION**

Quantidade / Cantidad / Amount	Código / Code	Descrição	Descripción	Description	C x L x E	L x W x T
1	P102190	LATERAL DIREITA	LADO DIRECTO	RIGHT SIDE	2285 x 540 x 15 mm	89.96 x 21.26 x 0.59 in
1	P102271	BASE	BASE	BASE	1553 x 540 x 15 mm	61.14 x 21.26 x 0.59 in
2	P102221	TAMPO DE GAVETA	TAPA DEL CAJÓN	TOP OF DRAWERS	769 x 470 x 15 mm	30.28 x 18.50 x 0.59 in
2	P102220	PRATELEIRA	ESTANTE	SHELF	769 x 448 x 15 mm	30.28 x 17.64 x 0.59 in
2	P102286	BASE	BASE	BASE	769 x 470 x 15 mm	30.28 x 18.50 x 0.59 in
1	P102270	CHAPÉU	SOMBRERO	HAT	1584 x 558 x 15 mm	62.36 x 21.97 x 0.59 in
1	P102209	LATERAL ESQUERDA	LADO IZQUERDA	LEFT SIDE	2285 x 540 x 15 mm	89.96 x 21.26 x 0.59 in
2	P102272	RODAPE	ZOCALO	BASEBOARD	1553 x 96 x 15 mm	61.14 x 3.78 x 0.59 in
4	P102231	COSTA	COSTA	COAST	2194 x 390 x 3 mm	86.38 x 15.35 x 0.12 in
4	P102202	LATERAL DE GAVETA	LADO DEL CAJÓN	DRAWER SIDE	400 x 120 x 15 mm	15.75 x 4.72 x 0.59 in
2	P102254	FUNDO DE GAVETA	FONDO DEL CAJÓN	DRAWER BOTTOM	678 x 398 x 3 mm	26.69 x 15.67 x 0.12 in
2	P102253	CABECEIRA DE GAVETA	CABEZAL DEL CAJÓN	DRAWER HEAD	665 x 120 x 15 mm	26.18 x 4.72 x 0.59 in
2	P102256	FRENTE DE GAVETA	FRENTE DEL CAJÓN	DRAWER FRONT	700 x 160 x 15 mm	27.56 x 6.30 x 0.59 in
4	P102206	AFASTADOR	RETRACTOR	SEPARADOR	384 x 70 x 25 mm	15.12 x 2.76 x 0.98 in
1	P102287	DIVISORIA	DIVISION	DIVISION	2174 x 470 x 15 mm	85.59 x 18.50 x 0.59 in
1	P102284	RODAPE	ZOCALO	BASEBOARD	454 x 96 x 15 mm	17.87 x 3.78 x 0.59 in

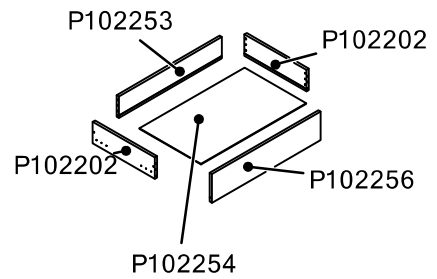
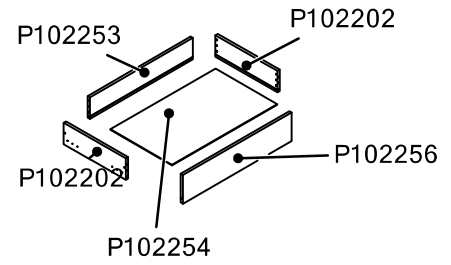
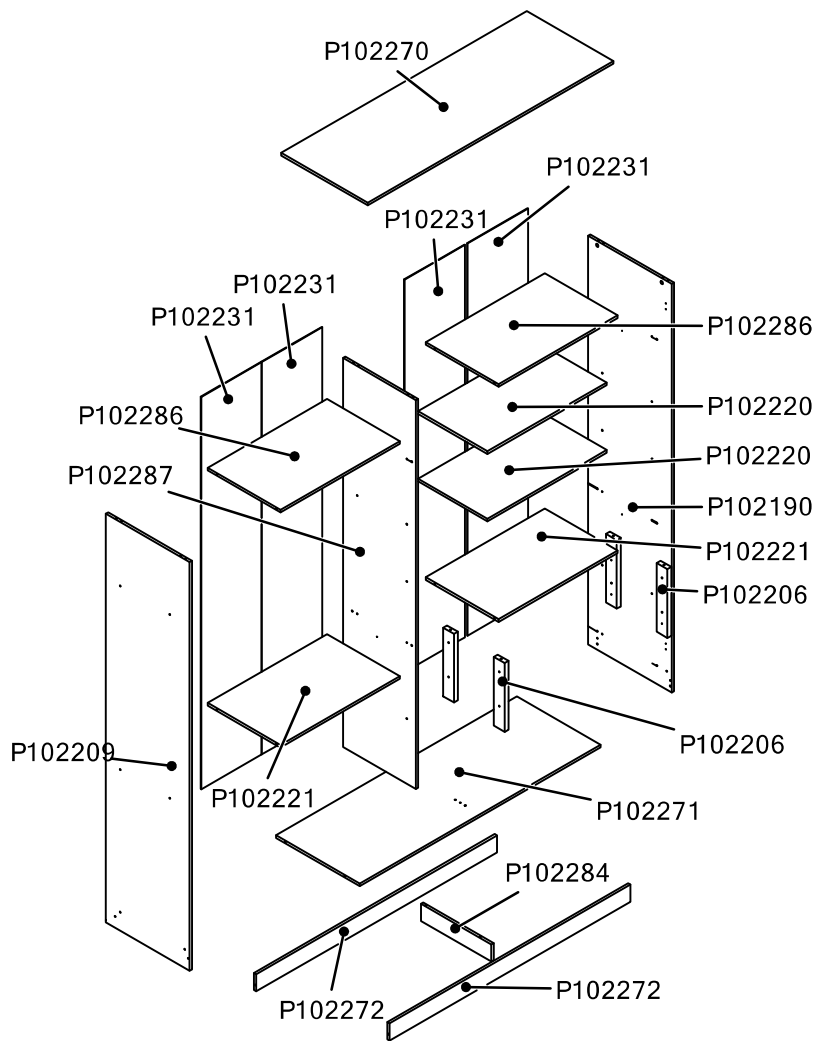

IDENTIFICAÇÃO DOS ACESSÓRIOS / IDENTIFICACIÓN DE ACCESORIOS
IDENTIFICATION OF ACCESSORIES

NOTAS: A separação dos acessórios antes de iniciar a montagem facilitará a mesma. Em caso de dúvida na identificação, coloque o acessório sobre a régua.

Nota: Separar los accesorios antes de iniciar el montaje facilitará el mismo. En caso de duda en la identificación, coloque el accesorio en la regla.

NOTE: Separating the accessories before starting assembly will make it easier. In case of doubt in the identification, place the accessory on the ruler.

	QTD.	CÓDIGO / CODE	DESCRIÇÃO	Descripción	Description
	1	000041	COLA BRANCA EM BISNAGA	SOBRE DE COLA	GLUE
	119	000107	PREGO 10 X 10	CLAVO 10 X 10	NAIL 10 X 10
	6	000108	PREGO 12 X 12	CLAVO 12 X 12	NAIL 12 X 12
	8	000118	SUP. P/ PRAT. 6 X 8MM	SOPORTE DE ESTANTE 6 X 8	SHELF SUPPORT 6 X 8
	26	000226	P.CHATO 4,0 X 40 CAB. PHILLIPS ZB/BC	TORNILLO 4X40MM	SCREW 4X40MM
	8	000414	P.PANELA 4,0 X 35 CAB. PHILLIPS ZB/BC	TORNILLO 4,0 X 35	SCREW 4,0 X 35
	11	000899	CANTONEIRA PLASTICA PRETA	CANTONERA	PLASTIC SUPPORT
	20	001423	FIXADOR DE COSTA	FIJADOR DE ESPALDA	BACK FIXER
	42	001802	CAVILHAS DE MADEIRA 6X30 PINUS	TARUGO 6X30MM	DOWEL 6X30MM

IDENTIFICAÇÃO DOS ACESSÓRIOS / IDENTIFICACIÓN DE ACCESORIOS
IDENTIFICATION OF ACCESSORIES

	6	001901	SAPATA DESLIZADORA PRETA 15 X 6	ZAPATO 15 X 6	SHOE 15 X 6
	6	001925	CAVILHA 6 X 50MM MADEIRA	TARUGO 6 X 50MM	DOWEL 6 X 50MM
	100	004214	P.CHATO 3,5 X 14 CAB. PHILLIPS REBAIXADA ZB	TORNILLO 3,5 X 14MM	SCREW 3,5 X 14MM
	4	005256	P.CHATO 4,0 X 20 CAB. PHILLIPS ZB/BC	TORNILLO PLANO 4,0 X 20 BC	FLAT SCREW 4,0 X 20 BC
	4	018458	SUPOORTE TRIANGULAR PRETO	SOPORTE TRIANGULO	TRIANGLE SUPPORT
	8	030945	PARAFUSO DE ACO P/ MINIFIX	TORNILLO DE ACERO PARA MINIFIX	STEEL SCREW FOR MINIFIX
	8	030950	TAMBOR P/ MINIFIX 15MM ZAMAQ 09.11.007	CILINDRO 15MM	BARREL 15MM
	2	035196	ROLICO OBLONGO 16X30 ALUMINIO FRISADO 761MM	ROLICO OBLONGO 16X30 ALUMINIO FRISADO 761MM	ROLICO OBLONGO 16X30 ALUMINIO FRISADO 761MM
	4	041921	SUP. P/ CABIDEIRO OBLONGO METAL COR ALU. ESCURO	SOPORTE PERCHA	CLOTHES RACK
	6	054117	P.CHATO 3,5 X 25 CAB. PHILLIPS ZB/BC (IDELLI)	TORNILLO 3,5 X 25	SCREW 3,5 X 25

IDENTIFICAÇÃO DOS ACESSÓRIOS / IDENTIFICACIÓN DE ACCESORIOS
IDENTIFICATION OF ACCESSORIES

	12	056243	P.FLANGE 3,5 X 12 CAB. PHILLIPS ZB/BC	TORNILLO 3,5 X 12	SCREW 3,5 X 12
	2	PH	PERF. H26 2190MM	PERFIL H 2190MM	PROFILE H 2190MM
	1	075334	TRILHO SUPERIOR 1552MM ALUMINIO NATURAL (TRL RX 1021)	CARRIL DE ALUMINÍO 2570MM	ALUMINUM RAIL 2570MM
	1	075335	TRILHO INFERIOR SOBREPOSTO 1552MM ALUMINIO NATURAL (PERFIL RX 1571)	TRILHO INFERIOR SOBREPOSTO 1552MM ALUMINIO NATURAL (PERFIL RX)	TRILHO INFERIOR SOBREPOSTO 1552MM ALUMINIO NATURAL (PERFIL RX 1571)
	4	076029	CARRINHO C/ROLDANA CONCAVA P/PORTA DE CORRER	CARRO DE PUERTA CORREDERA	SLIDING DOOR TROLLEY
	4	076030	GUIA SUPERIOR 26MM P/PORTA DE CORRER	GUIA SUPERIOR 26MM P/PORTA DE CORRER	GUIA SUPERIOR 26MM P/PORTA DE CORRER
	4	076031	FREIO SUPERIOR P/PORTA DE CORRER	FREIO SUPERIOR P/PORTA DE CORRER	FREIO SUPERIOR P/PORTA DE CORRER
	2	CRTM400X30	CORREDICA TELESCOPICO MINI LIGHT (H32/30) 400MM	CORREDERA METÁLICA 400MM	METAL SLIDE 400MM
	16	13MM	TAPA FURO 13MM	TAPA DEL AGUJERO 13MM	SCREW CAP COVER 13MM
	8	19MM	TAPA FURO 19MM	TAPA DEL AGUJERO 19MM	S+A1:F30CREW CAP COVER 19MM

INSTALAÇÃO MINIFIX

Identificar seta no corpo do tambor de minifix. A seta DEVE apontar para o buraco na borda do painel. Empurrar o tambor até o buraco.

INSTALACIÓN DE LA LEVA

Identifique la flecha en los muertos de la leva. La flecha debe apuntar hacia el agujero en el borde del panel. Empuje la leva hasta el fondo del orificio.

INSTALLING CAM

Identify arrow on head of cam. Arrow MUST point toward hole in edge of panel. Push cam all the way down into hole.

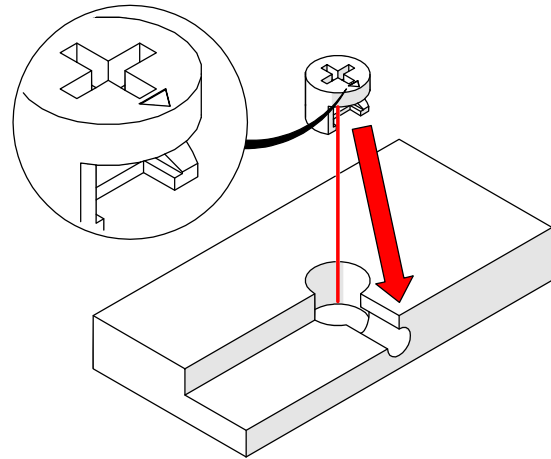

ALINHAMENTO DO TAMBOR E PARAFUSO

A seta do tambor de minifix deve ser aponta para o buraco e inserir o parafuso do minifix do tambor contido no buraco. Certifique-se de que as peças se unam.

ALINEACIÓN DE LA LEVA Y EL PASADOR

Asegúrese de que la flecha de la leva apunte hacia el orificio e inserte la clavija de la leva en el orificio. Asegúrese de que las piezas se unen.

CAM AND DOWEL ALIGNMENT

Ensure the arrow on the cam points toward hole and insert cam dowel into hole. Make sure pieces join together.

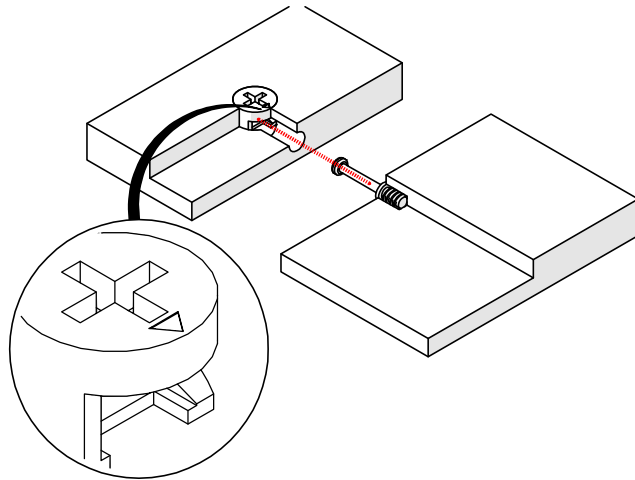

CÂMARA DE COMPENSAÇÃO DE TENSÃO

Use uma chave de fenda para girar a came. Girar o tambor minifix (no sentido horário) até que esteja totalmente apertado. Ligeiramente mais de meia volta.

APRIETE DE LA LEVA

Utilice un destornillador para girar la leva. Gire la leva (en el sentido de las agujas del reloj) hasta que esté completamente apretada. Un poco más de media vuelta.

TIGHTENING CAM

Use screwdriver to turn cam. Turn cam (clockwise) until fully tightened. Slightly more than half a turn.

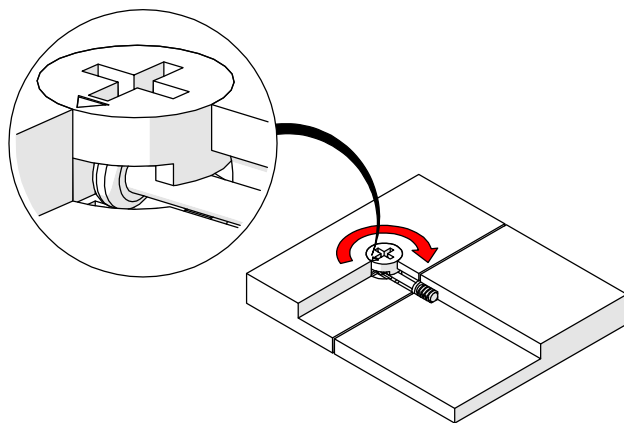

PASSO / PASO / STEP 1

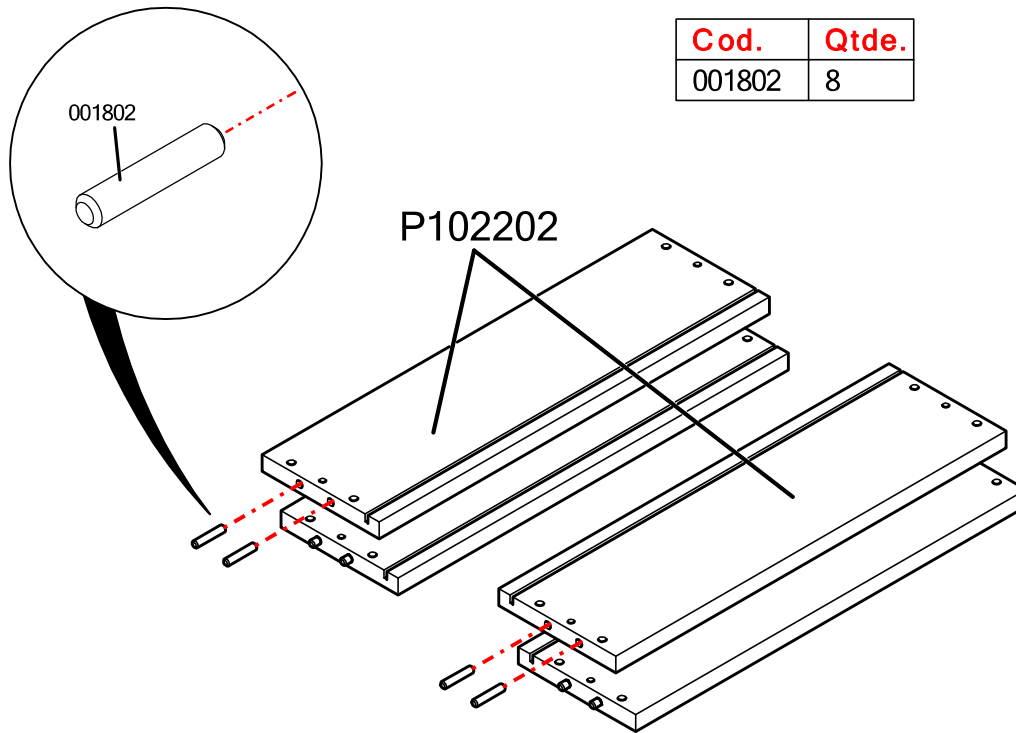

Cod.	Qtde.
001802	8

PASSO / PASO / STEP 2

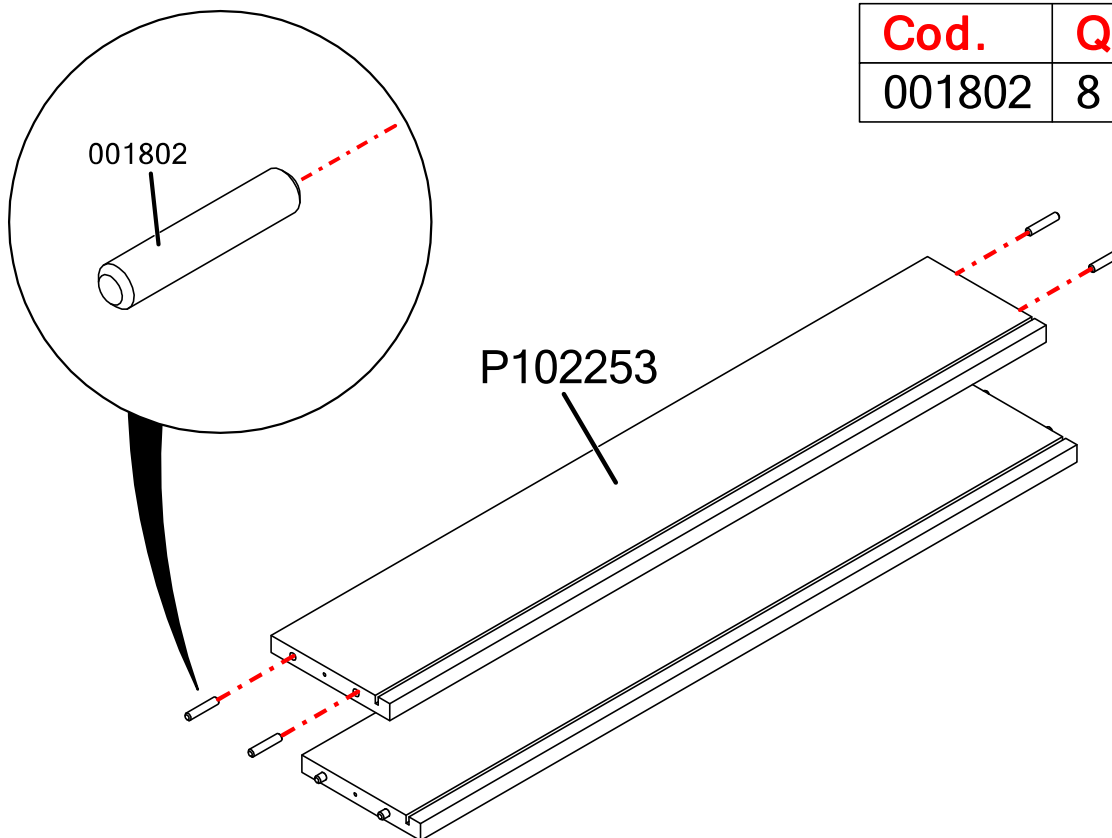

Cod.	Qtde.
001802	8

PASSO / PASO / STEP 3

Cod.	Qtde.
000226	4

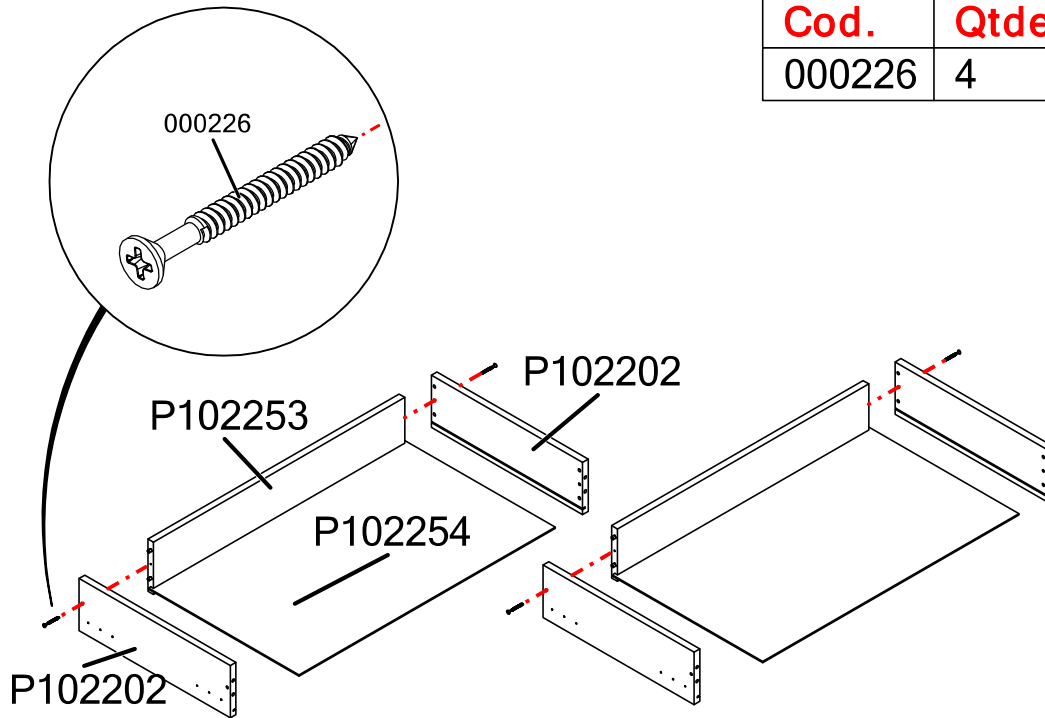

PASSO / PASO / STEP 4

Cod.	Qtde.
000899	4
004214	16

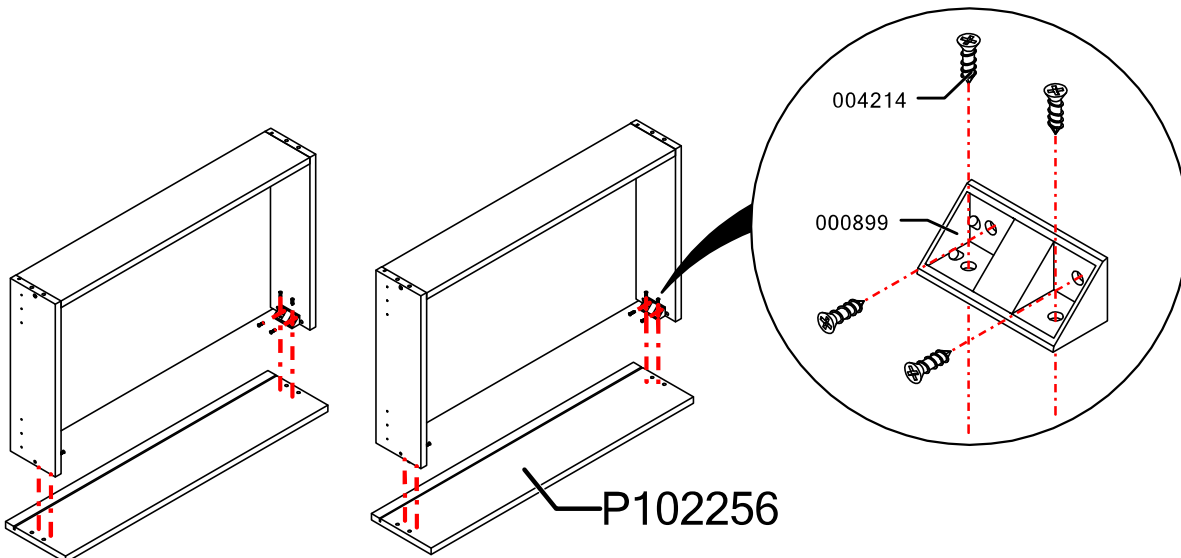

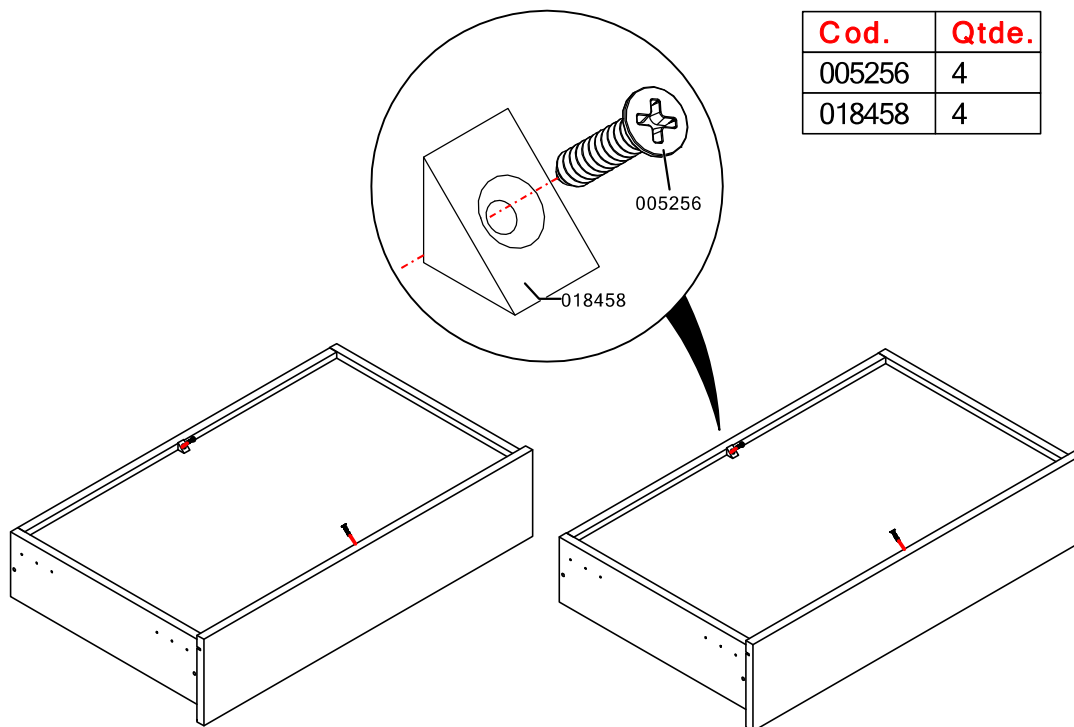

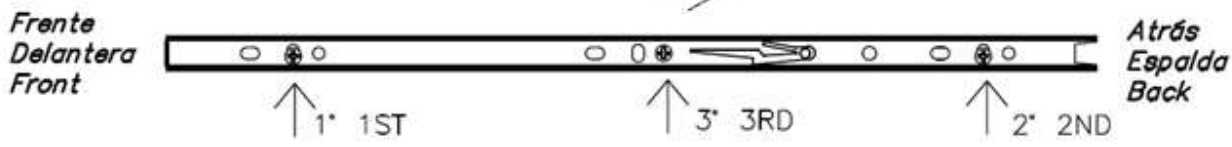
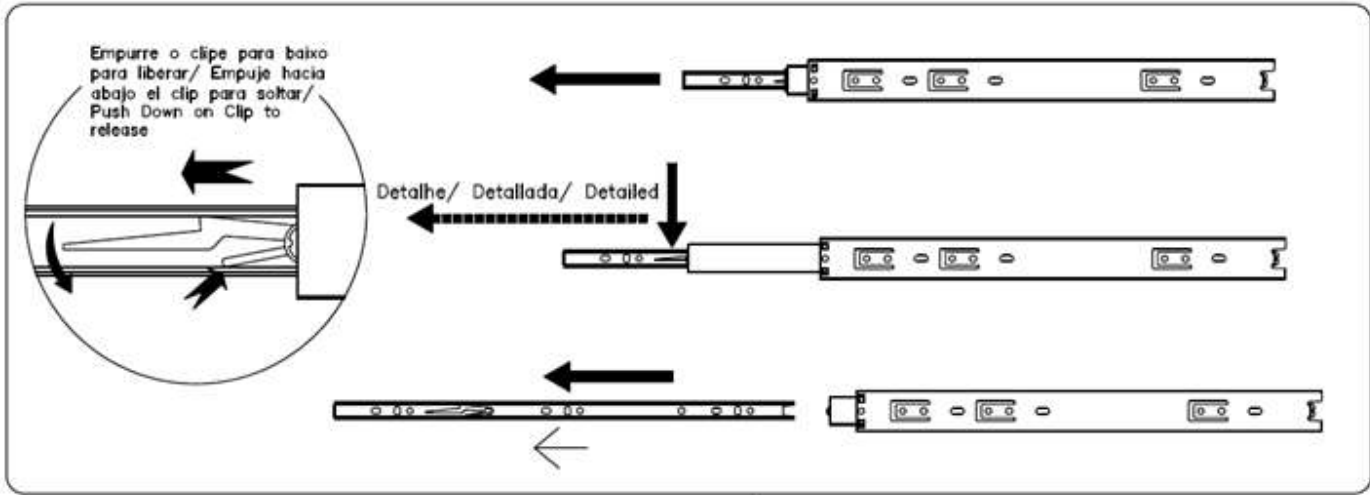

PASSO / PASO / STEP 6

Cod.	Qtde.
004214	12
038305	2

Atrás / Espalda /

Central / Centro /

Frente / Delantera

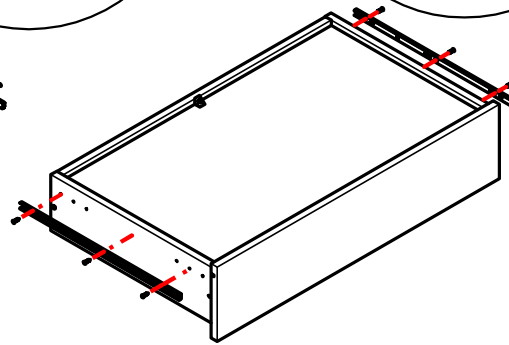
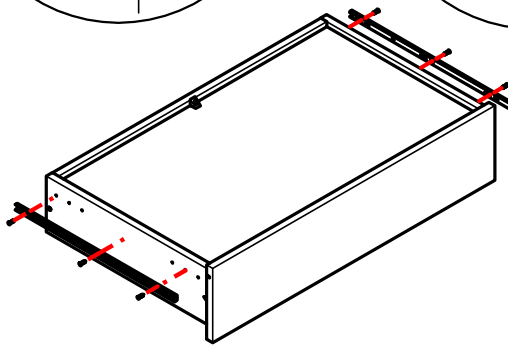
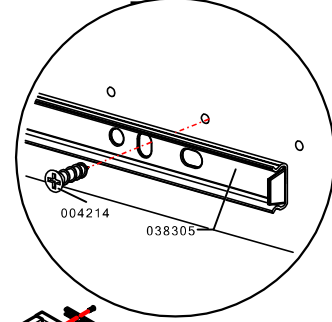
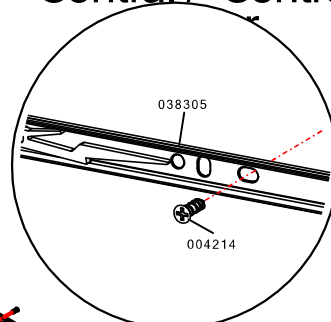
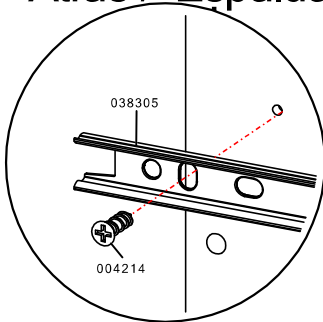

ARM158BMDP

12

PASSO / PASO / STEP 7

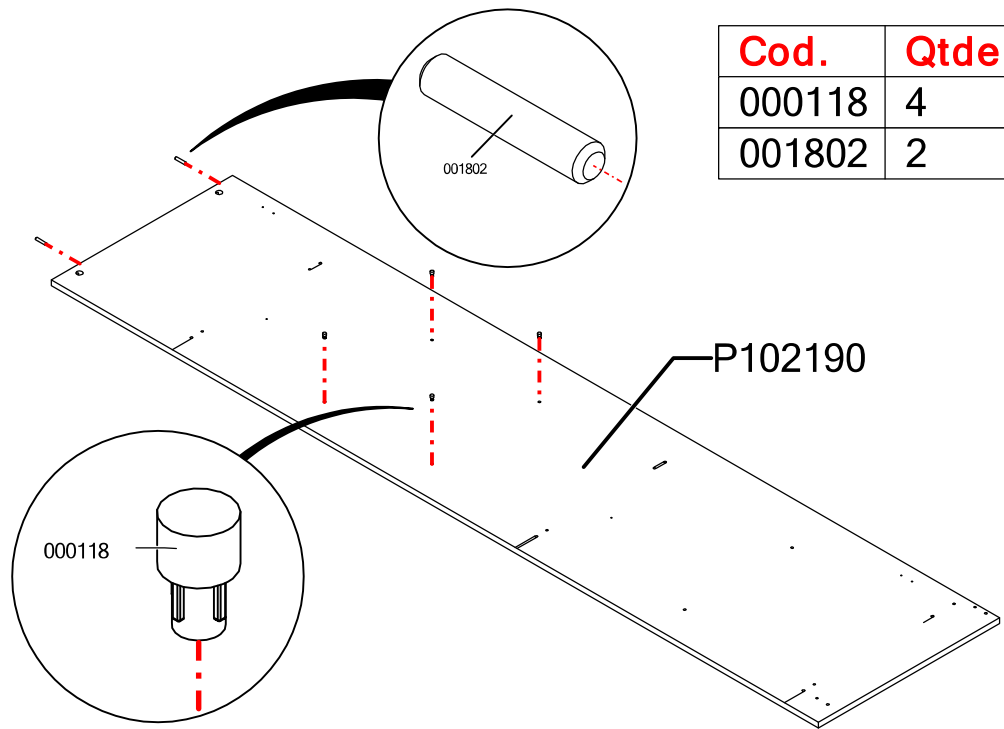

Cod.	Qtde.
000118	4
001802	2

PASSO / PASO / STEP 8

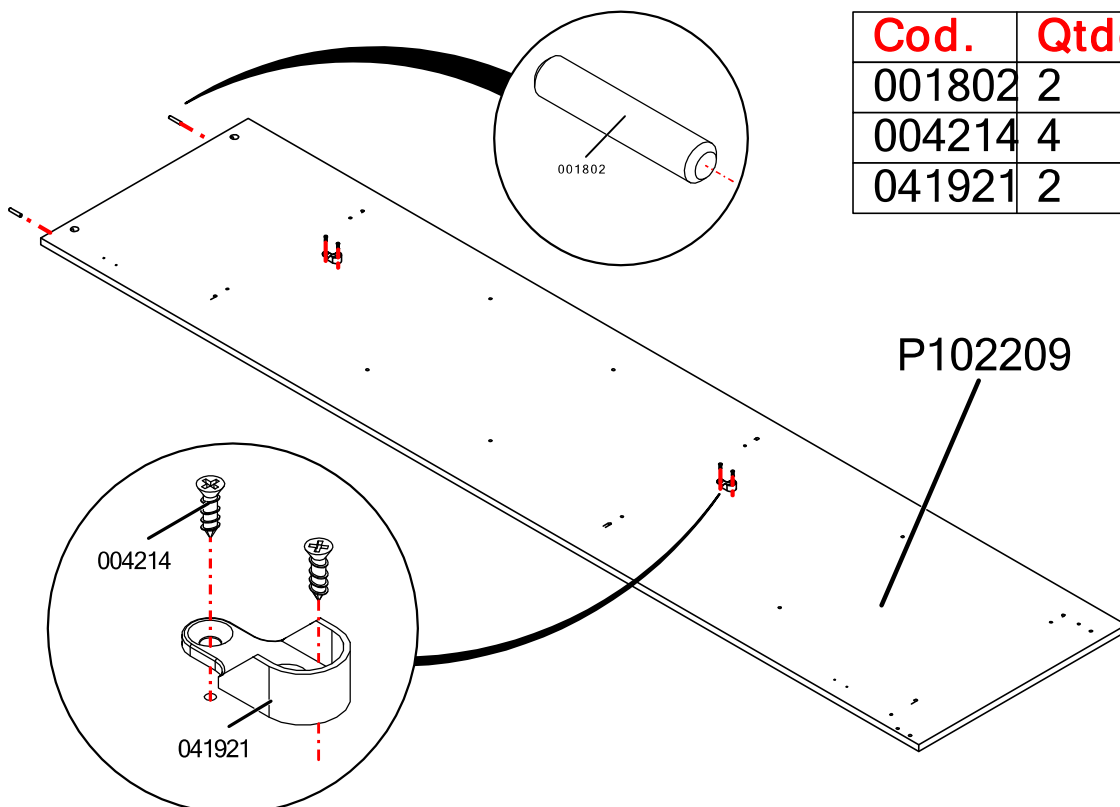

Cod.	Qtde.
001802	2
004214	4
041921	2

PASSO / PASO / STEP 9

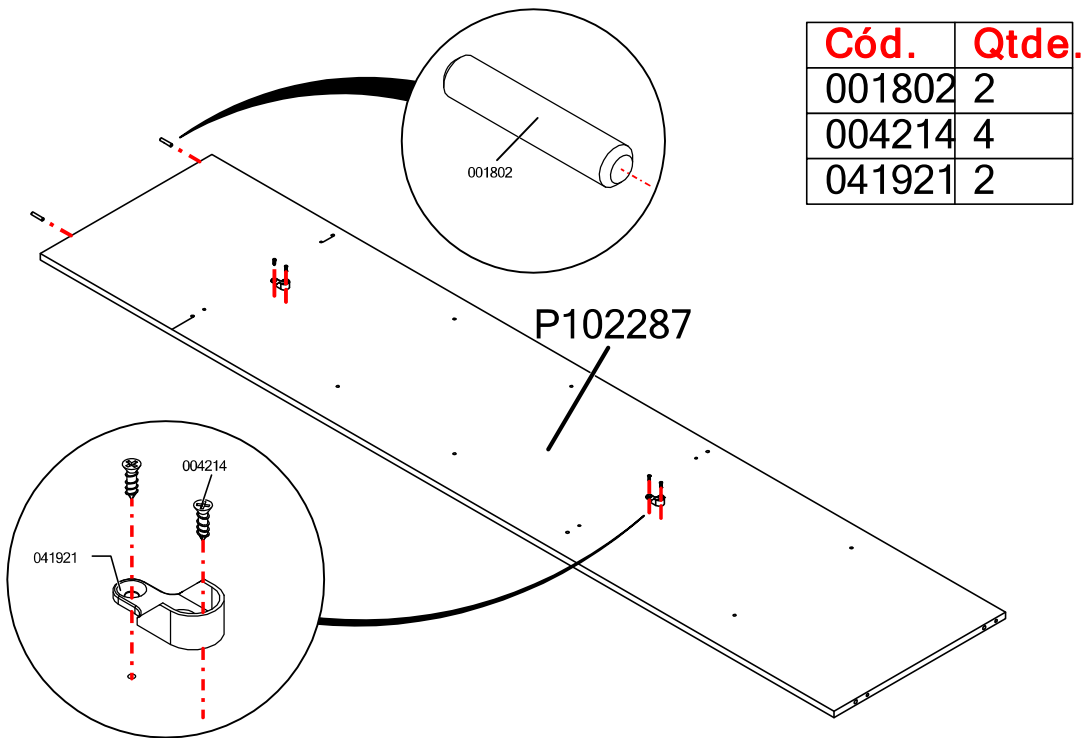

Cód.	Qtde.
001802	2
004214	4
041921	2

PASSO / PASO / STEP 10

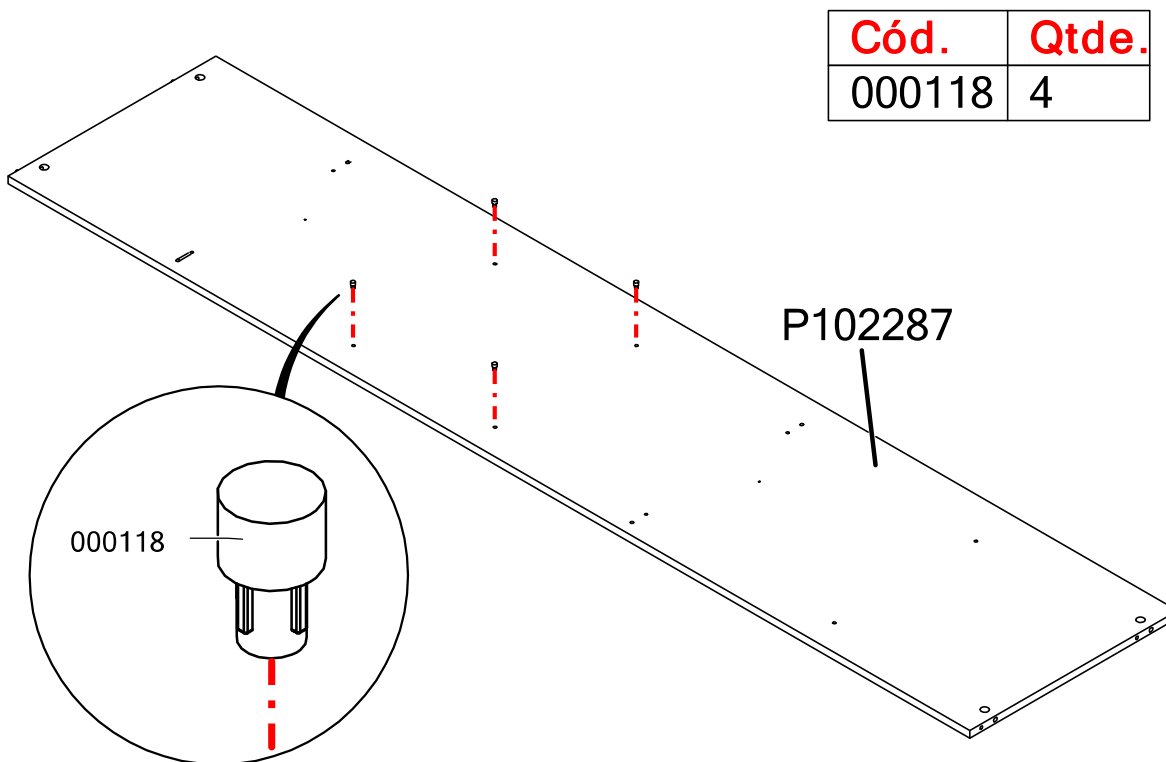

Cód.	Qtde.
000118	4

PASSO / PASO / STEP 11

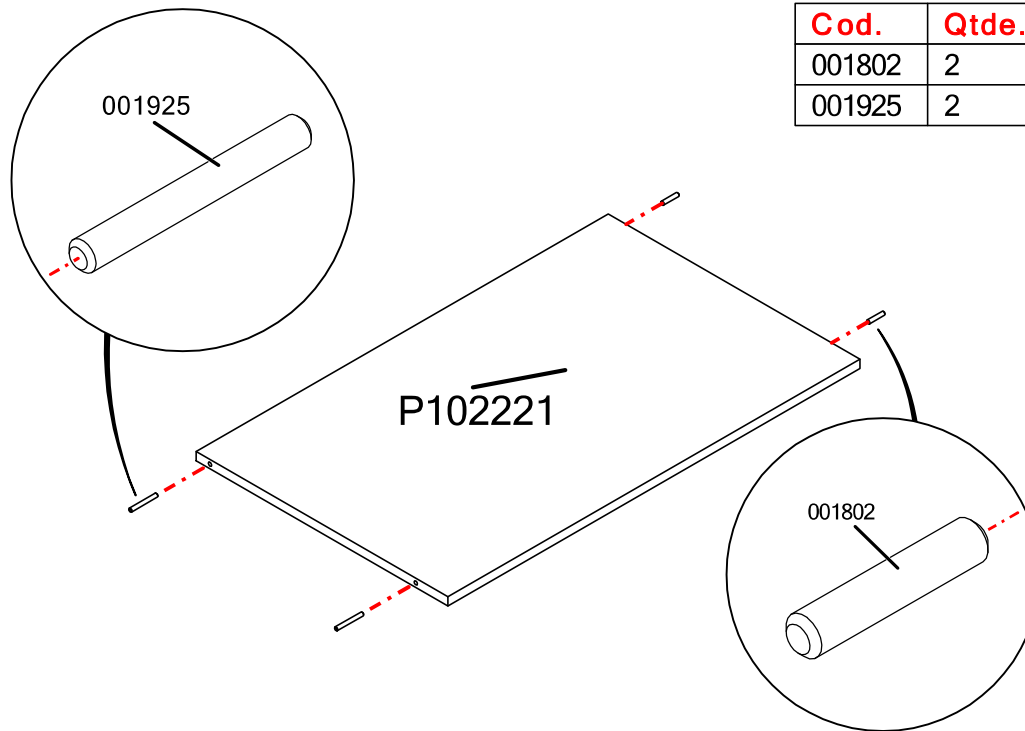

Cod.	Qtde.
001802	2
001925	2

PASSO / PASO / STEP 12

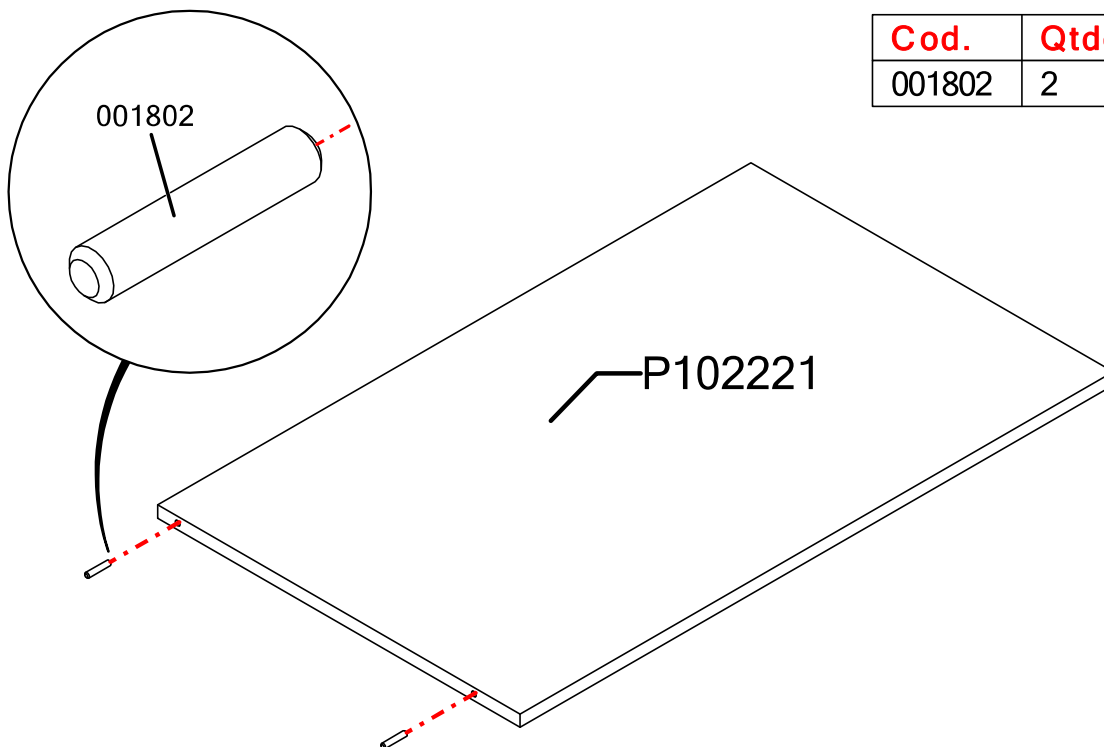

Cod.	Qtde.
001802	2

PASSO / PASO / STEP 13

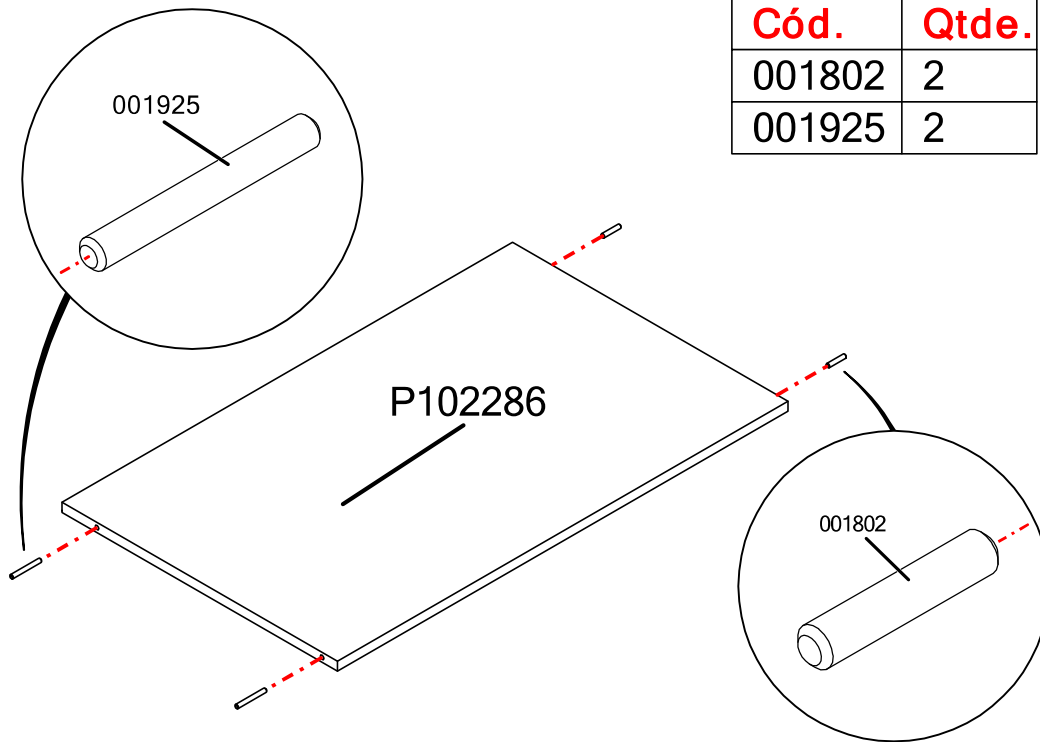

Cód.	Qtde.
001802	2
001925	2

PASSO / PASO / STEP 14

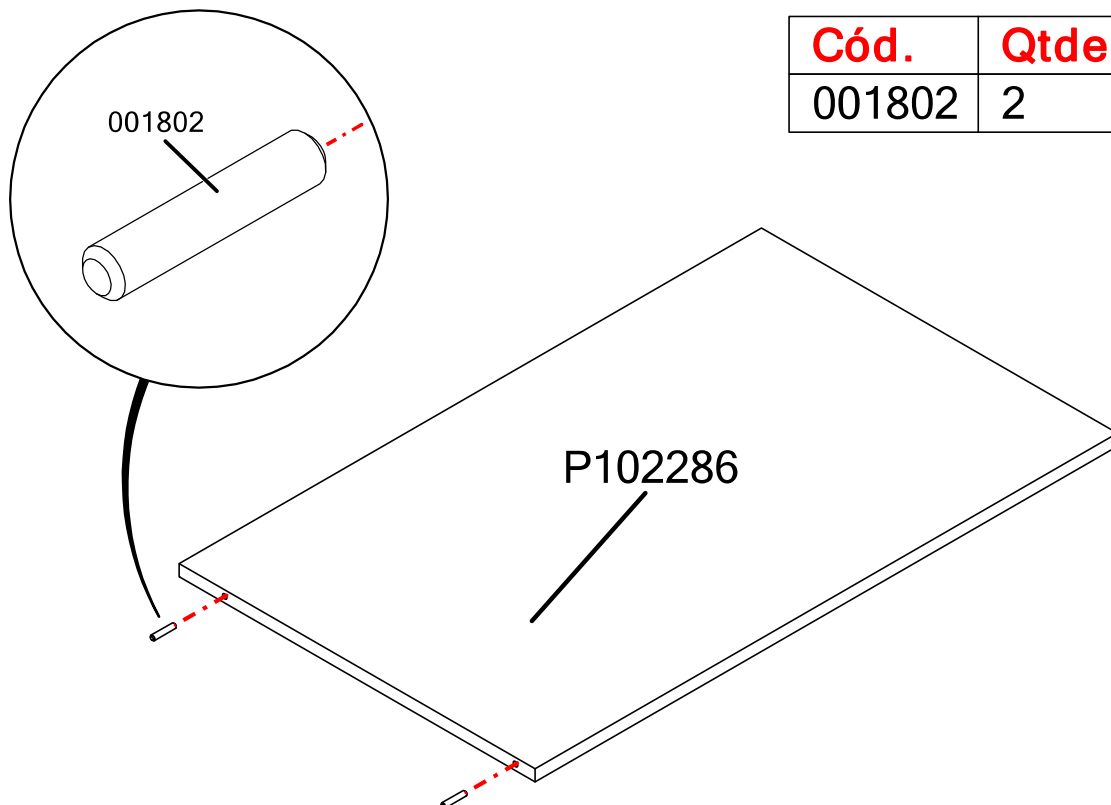

Cód.	Qtde.
001802	2

PASSO / PASO / STEP 15

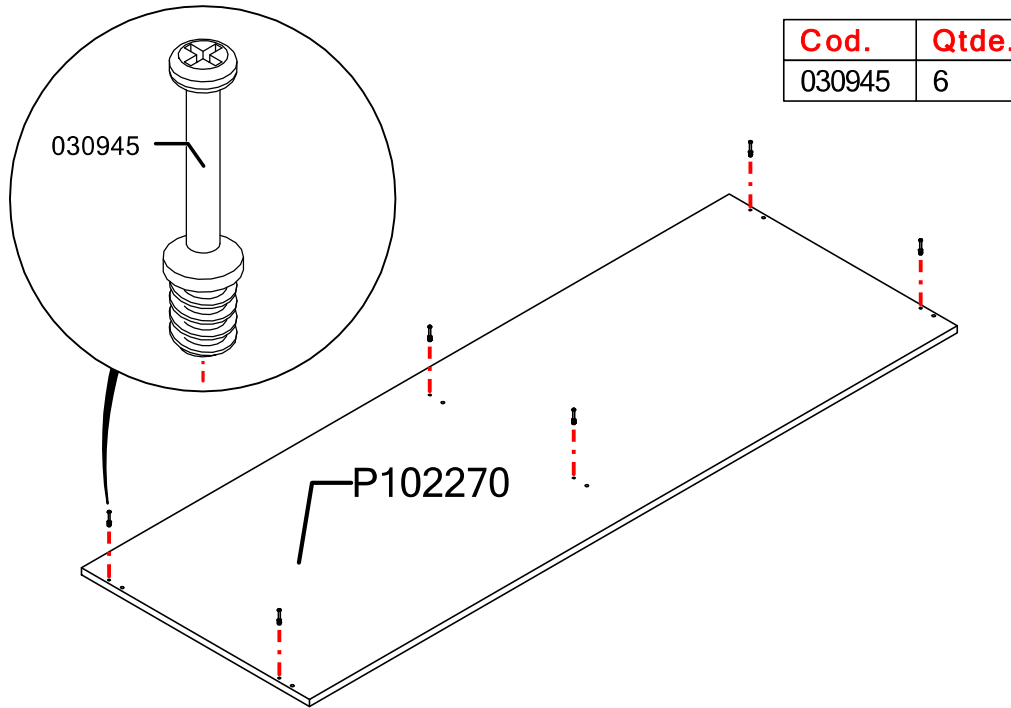

Cod.	Qtde.
030945	6

PASSO / PASO / STEP 16

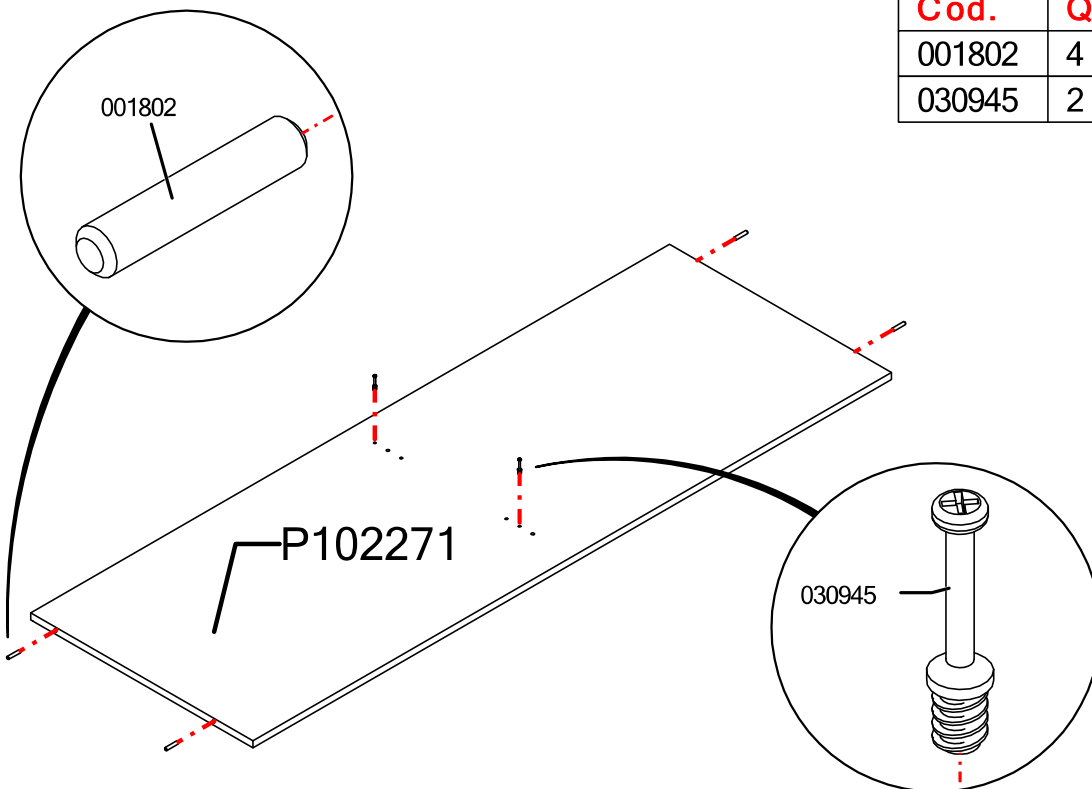

Cod.	Qtde.
001802	4
030945	2

PASSO / PASO / STEP 17

Cod.	Qtde.
001802	4

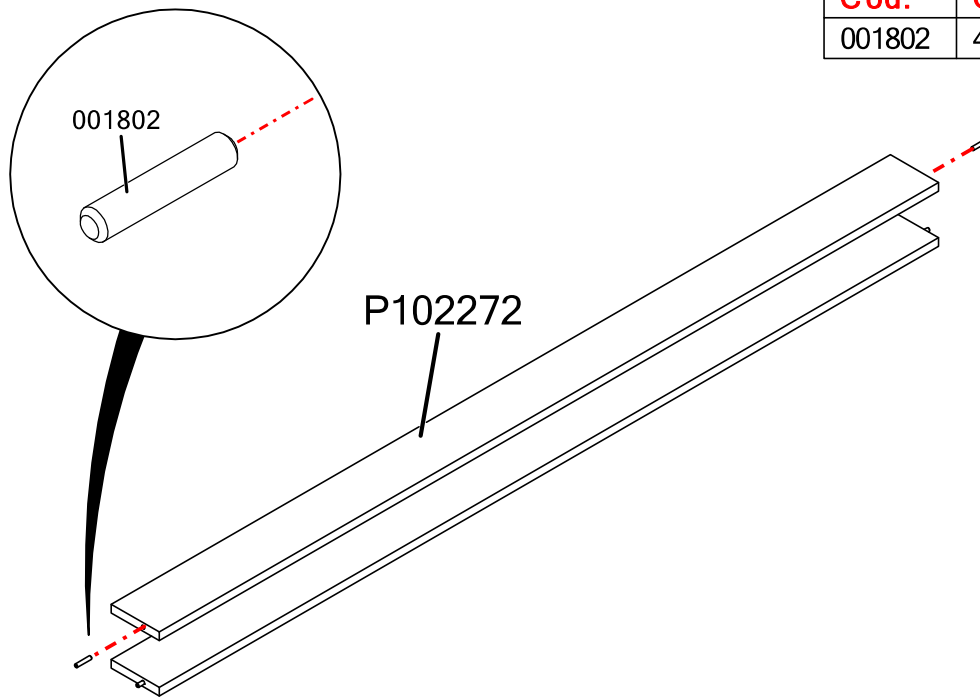

PASSO / PASO / STEP 18

Cod.	Qtde.
001925	2

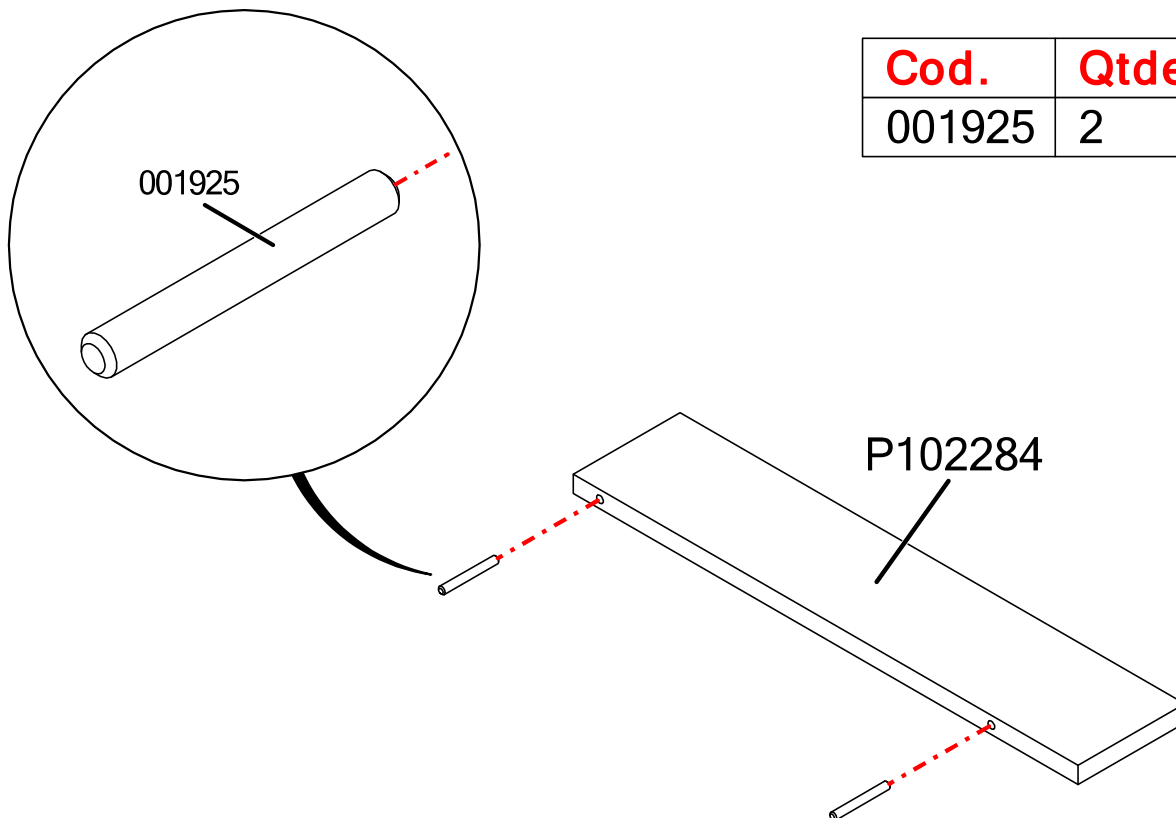

PASSO / PASO / STEP 19

Cod.	Qtde.
000226	2

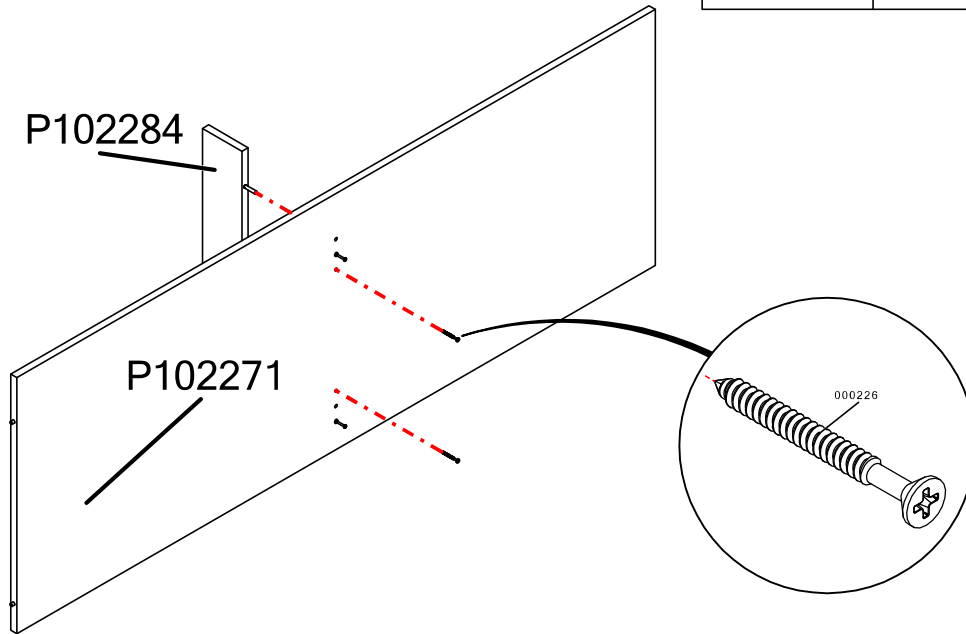

PASSO / PASO / STEP 20

Cód.	Qtde.
030950	2
19MM	2

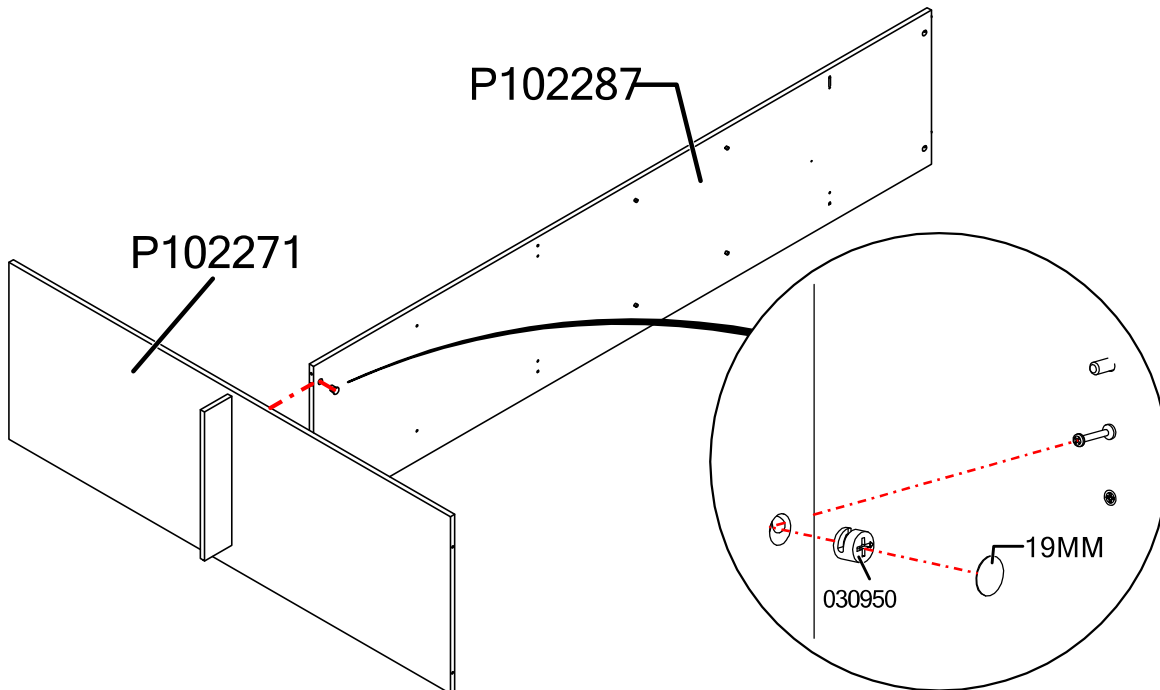

PASSO / PASO / STEP 21

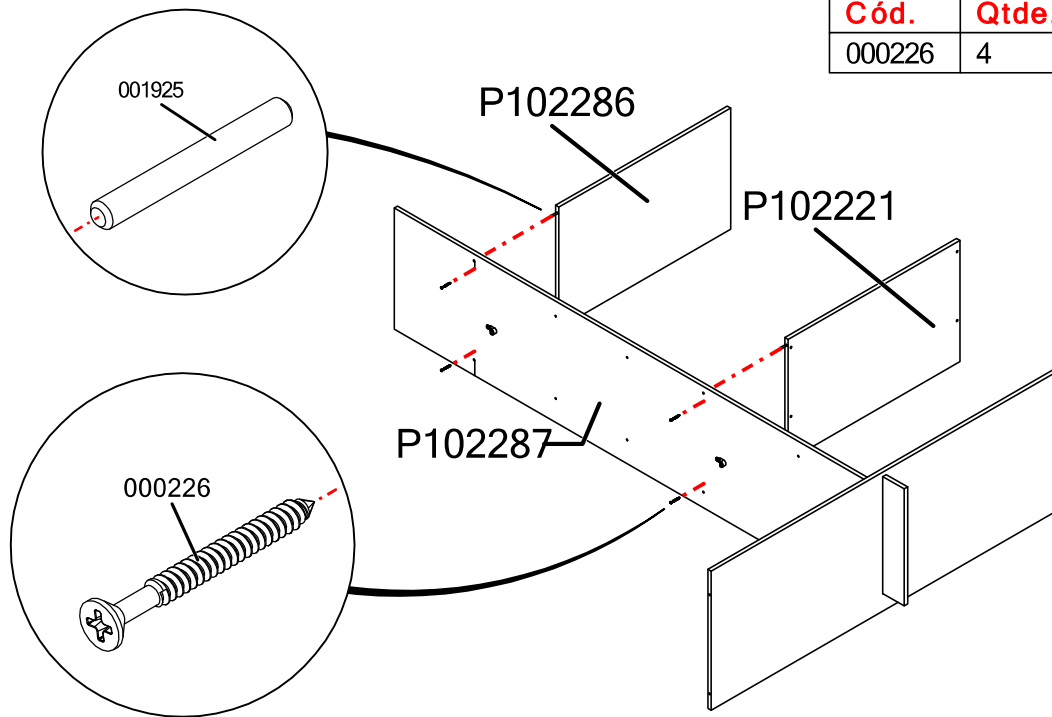

Cód.	Qtde.
000226	4

PASSO / PASO / STEP 22

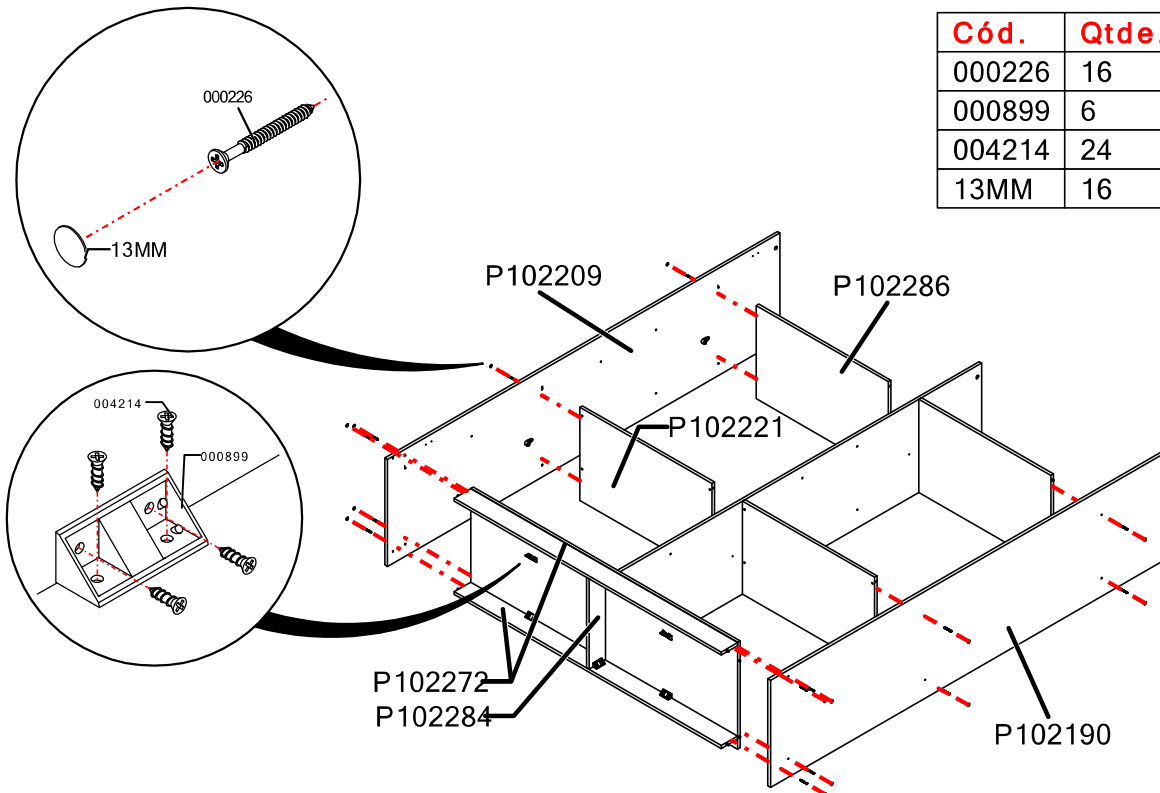

Cód.	Qtde.
000226	16
000899	6
004214	24
13MM	16

PASSO / PASO / STEP 23

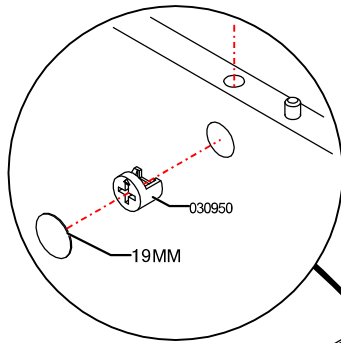

Cod.	Qtde.
030950	6
19MM	6

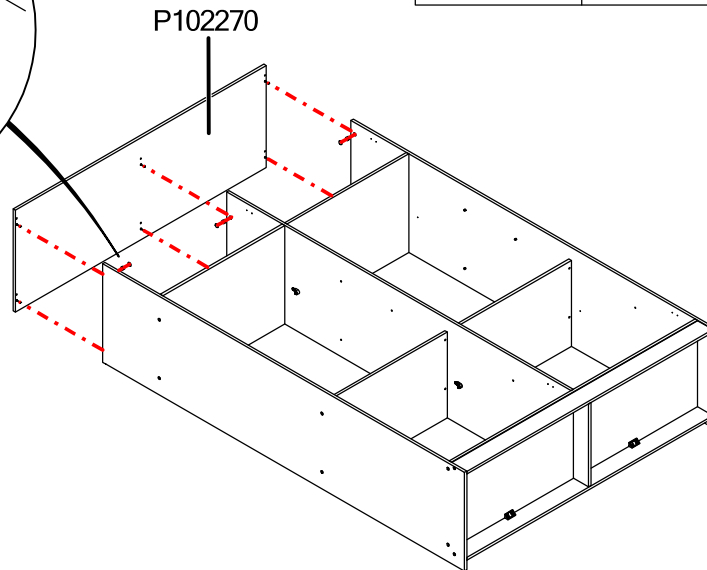

PASSO / PASO / STEP 24

Cod.	Qtde.
000108	6
001901	6

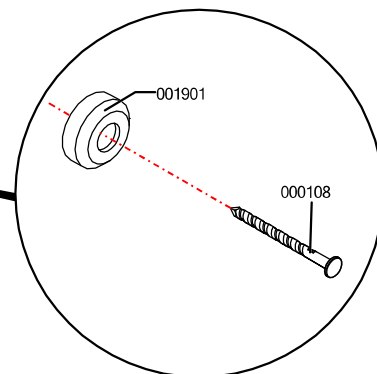
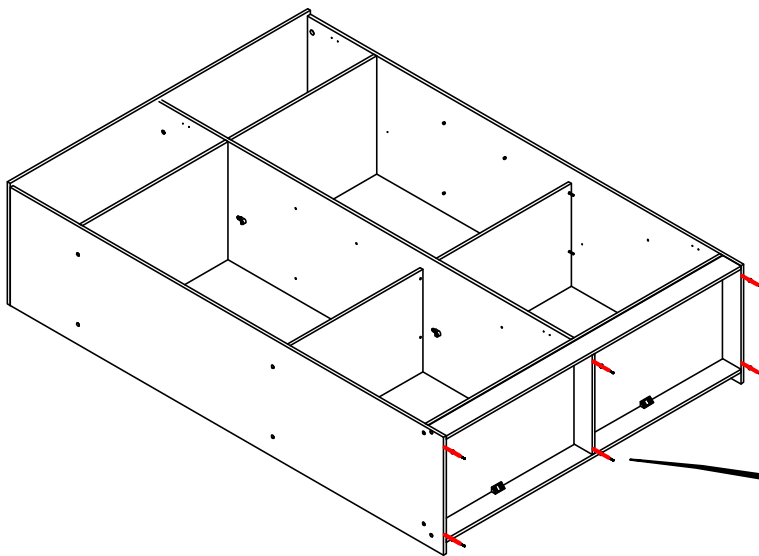

PASSO / PASO / STEP 25

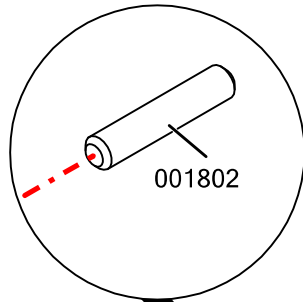

001802

P102206

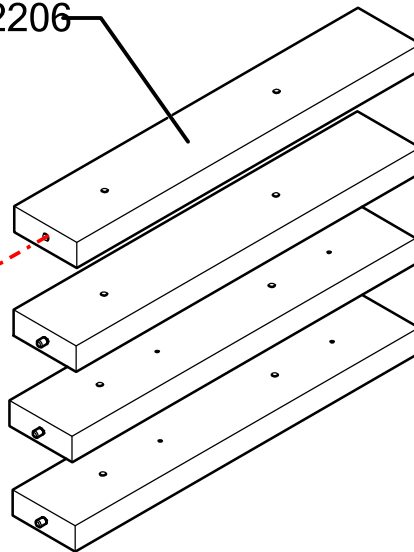

Cod.	Qtde.
001802	4

PASSO / PASO / STEP 26

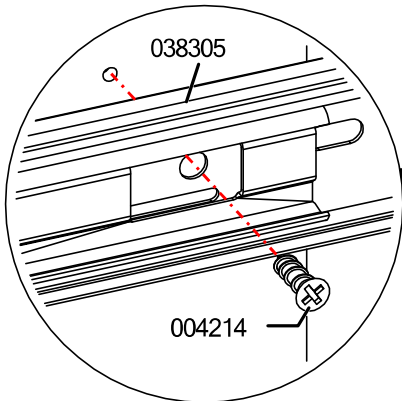

038305

004214

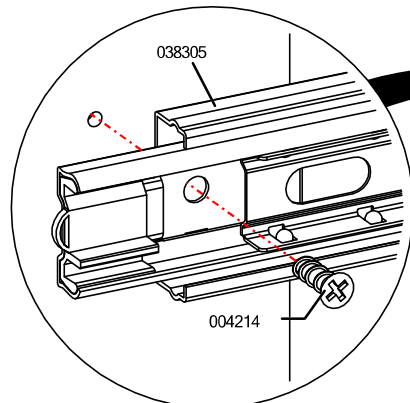

038305

004214

Cod.	Qtde.
004214	8
038305	2

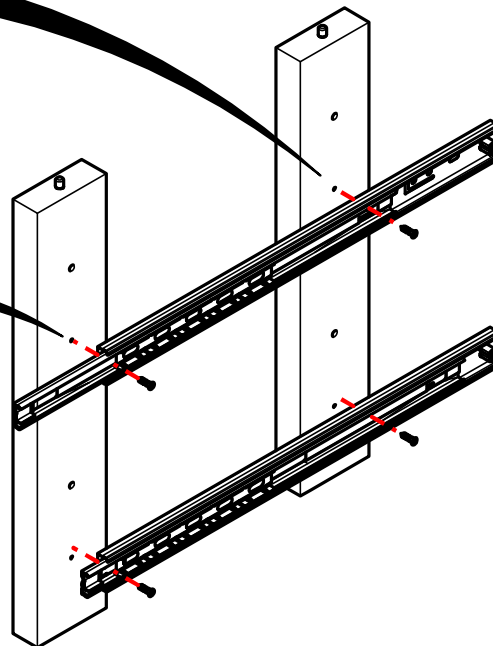

PASSO / PASO / STEP 25

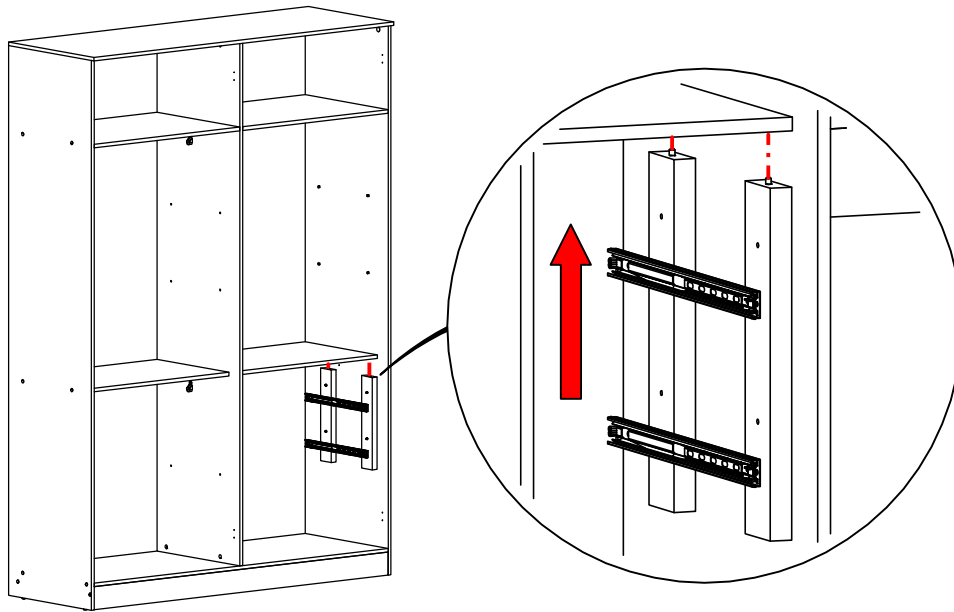

PASSO / PASO / STEP 26

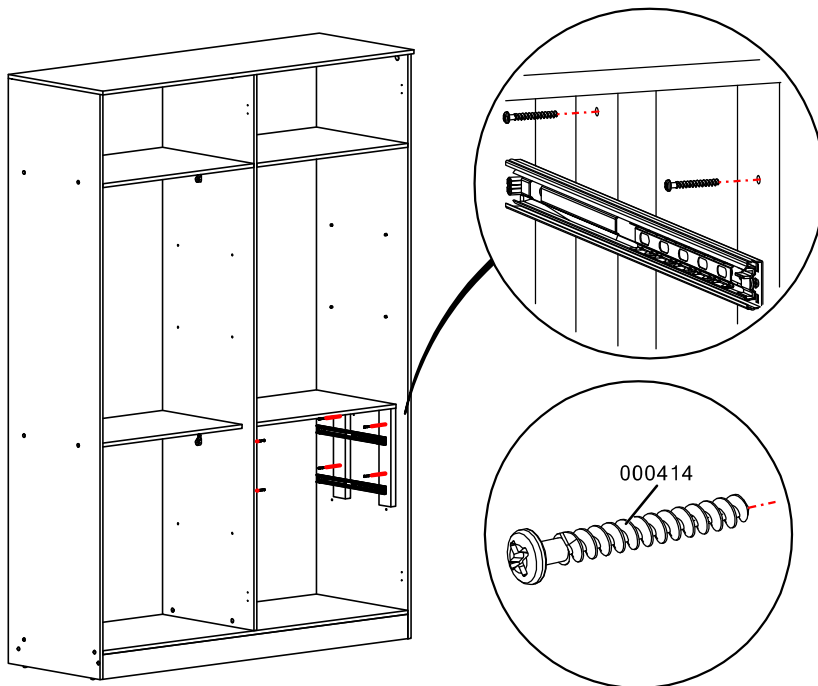

Cod.	Qtde.
000414	8

PASSO / PASO / STEP 27

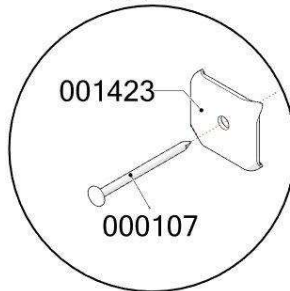
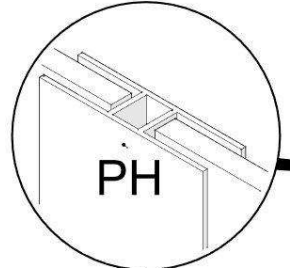
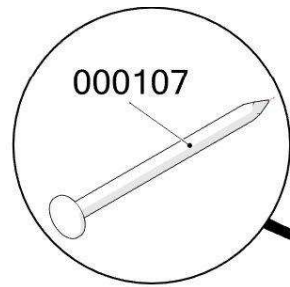

Cód.	Qtde.
000107	119
001423	20
PH	2

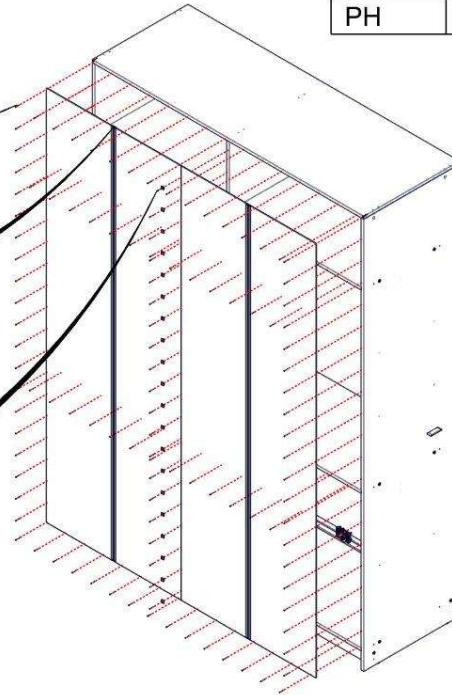

PASSO / PASO / STEP 28

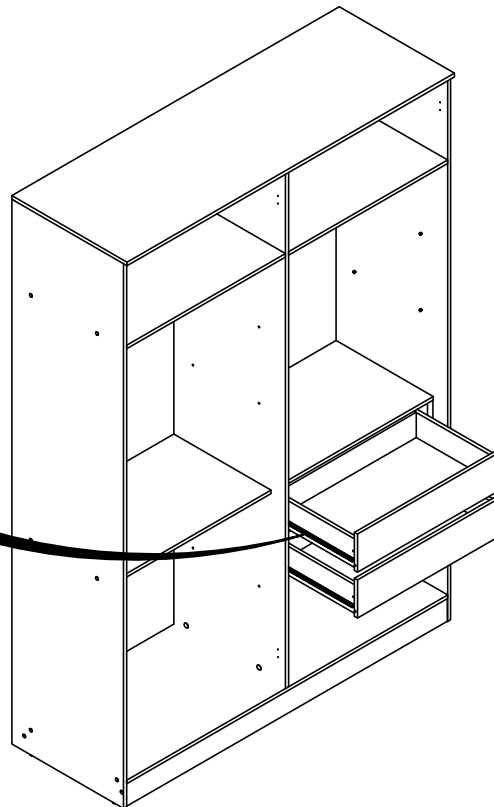
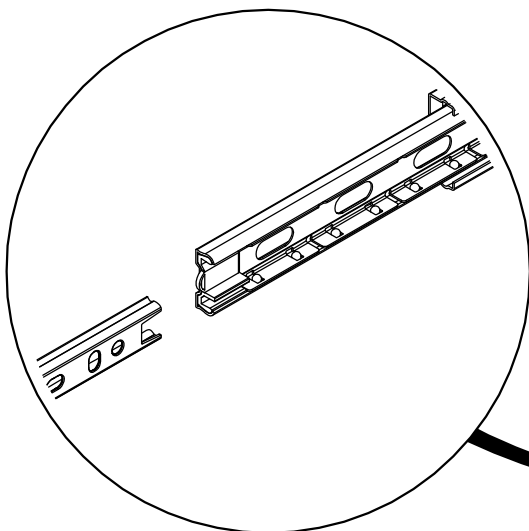

ARM158BMDP

PASSO / PASO / STEP 29

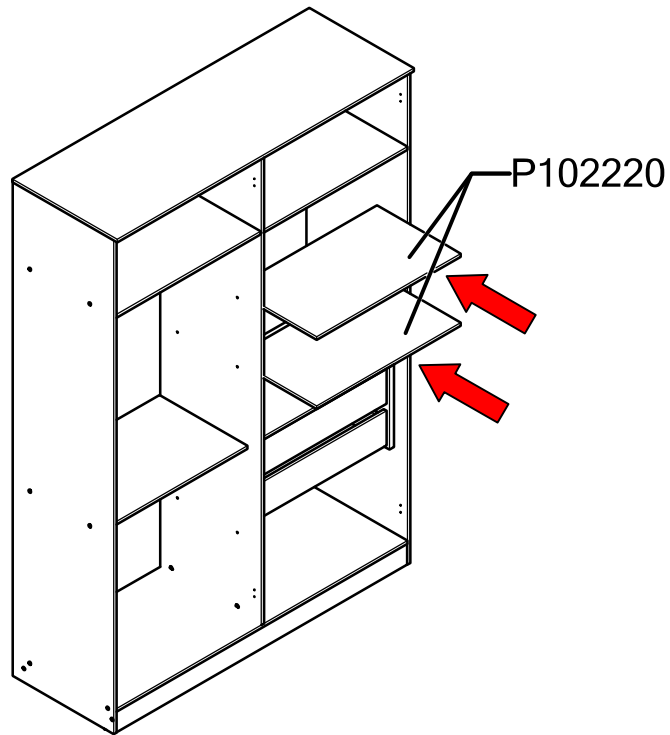

PASSO / PASO / STEP 30

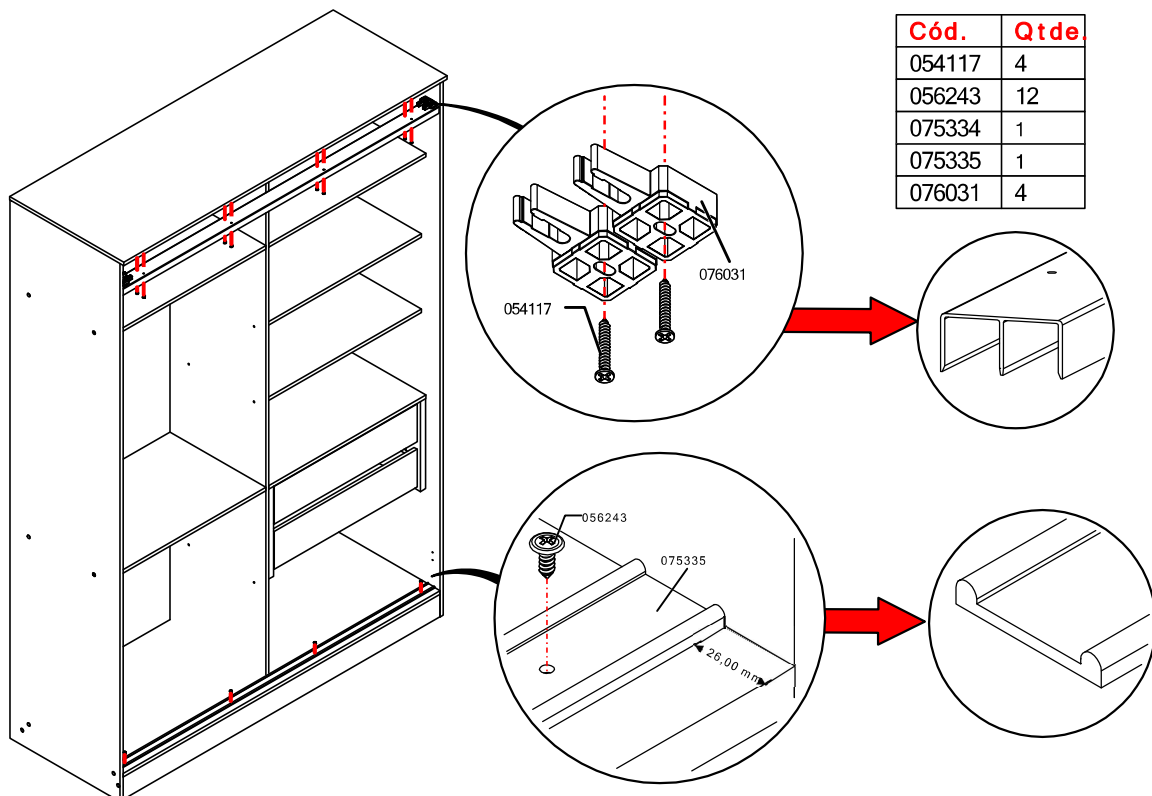

Cód.	Qtde
054117	4
056243	12
075334	1
075335	1
076031	4

PASSO / PASO / STEP 31

