

CÓDIGO / CODE:	ALTIURA	LARGURA:	PROFUNDIDADE
A998	183 - COM PÉ 190	1100	470

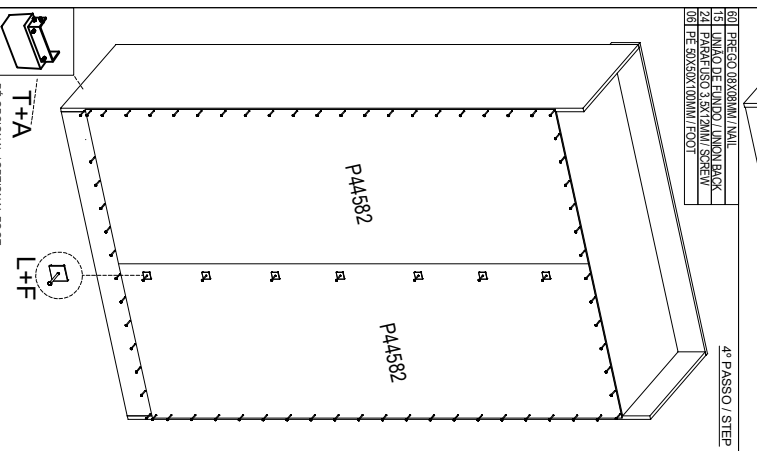

LISTAGEM DE PEÇAS / LIST OF PARTS				
P0	LISTA DE PEÇAS / LIST OF PARTS	MEDIDAS / MEASURES	QTD.	
P44587	BASE / BASE	12MM	544	450
P44588	BASE DA PORTA-CHAPÉU / BASE OF DOOR-TOP	12MM	1072	450
P44600	RODAPE FRONTAL / FRONT VIEW	12MM	1072	100
P44589	RODAPE TRASEIRO / BACK VIEW	12MM	1072	100
P44590	TRAVA DO RODAPE / SUPPORT VIEW	12MM	420	100
P44591	PRATELEIRA / SHELVES	12MM	531	450
P44601	VISTA SUPERIOR / SUPERIOR VIEW	12MM	1096	100
P44602	LATERAL DIREITA / RIGHT SIDE	12MM	1830	450
P44592	DIVISÃO / DIVISION	12MM	463	450
P44593	BATENTE FRONTAL / FRONT VIEW	12MM	1135	90
P44594	BATENTE TRASEIRO / SUPPORT BACK	12MM	1135	90
P44603	LATERAL ESQUERDA / LEFT SIDE	12MM	1830	450
P44586	PORTA MAIOR DIRESO / DOOR	12MM	1630	268
P44584	PORTA CENTRAL / DOOR	12MM	1144	268
P44585	FRENTE DE GAVETA / DRAWER FRONT	12MM	540	239
P44595	LATERAL DE GAVETA / DRAWER SIDE	12MM	350	100
P44596	CONTRA FUNDO / DRAWER BACK	12MM	481	100
P44597	FUNDO DE GAVETA / DRAWER BACK	03MM	355	503
P44582	FUNDO / BACK	03MM	1645	544

LISTA DE ACESSÓRIOS / LIST OF ACCESSORIES				
A	PARAFUSO 3,5 X 12MM / SCREW	98	1	
B	PARAFUSO 3,5 X 25MM / SCREW	14	1	
C	PARAFUSO 3,5 X 40MM / SCREW	48	1	
D	PARAFUSO 4x25MM / SCREW	8	1	
E	PORÇA M4 / NUT	8	1	
F	PREGO 08 x 08MM / NAIL	80	1	
H	CAVILHA 6X30MM / PLUG	8	1	
I	COLA / GLUE	1	1	
J	LOGOMARCA / TAG	1	1	
K	CANTONEIRA / METAL CONNECTION	10	1	
L	UNIÃO DE FUNDO / UNION BACK	15	1	
M	DOBRADÇA / METAL HINGE	12	1	
N	CORREDIÇA 350MM / RAILS	2	1	
O	PUXADOR VENEZA 128MM / HANDLE	6	1	
Q	SUPORTE MEIA CAVA SPINO / SUPPORT	1	1	
R	SUPORTE U ABERTO CENTRAL / SUPPORT U	1	1	
S	CAIÇÃO P-CANÊCA DOBRADÇA / PART OF HINGE	12	1	
T	PÉ U 50X40X100MM / FOOT	4	1	
U	CABIDEIRO DE MADEIRA 540MM / SUPPORT CLOTHES	1	1	

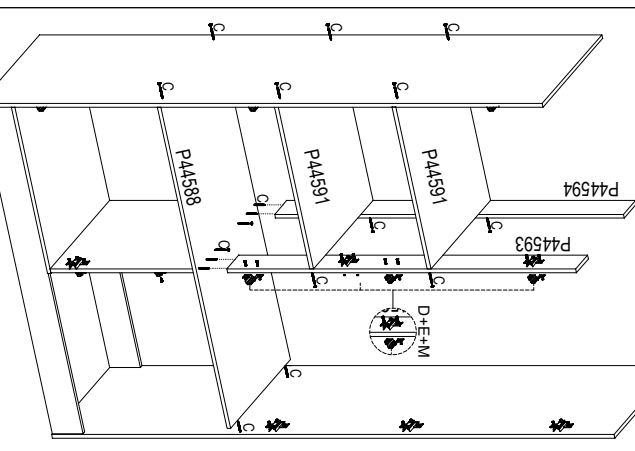
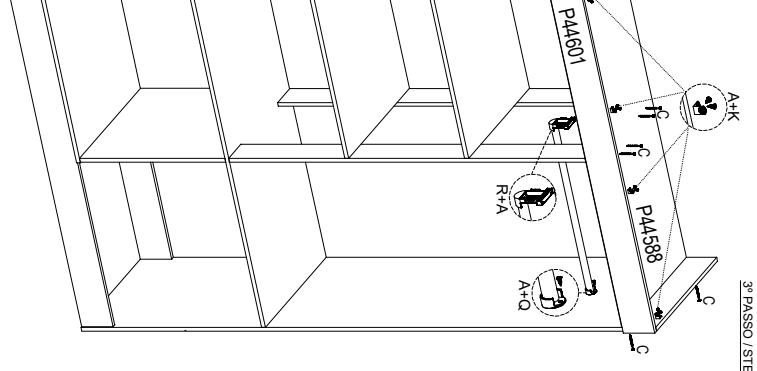
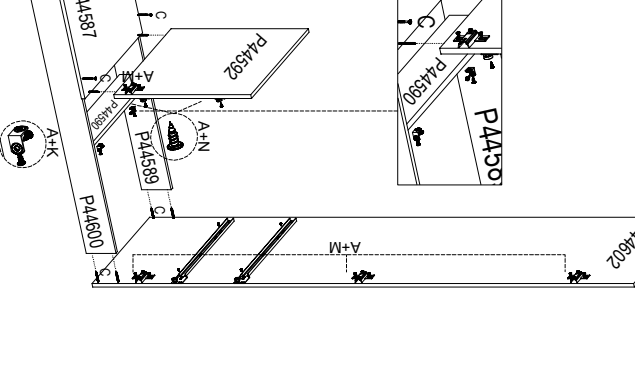
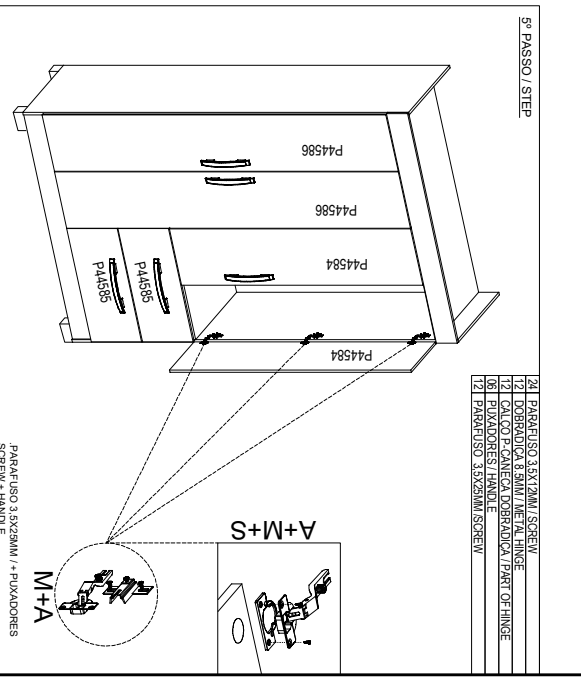

**1 Person** Hammer Screwdriver Key philips

**1 pessoa** Martelo Parafusadeira Chaves philips

**ATENÇÃO**

- 1 - Leia e observe atentamente toda a instrução antes de iniciar a montagem.
- 2 - A montagem do produto deve ser feita em uma superfície limpa e plana.
- 3 - As instruções devem ser seguidas cuidadosamente.
- 4 - Evite trabalhar em condições com climas extremos.

**LIMPEZA**

- 1 - Limpe o produto com um pano úmido e seco, seguido de um pano seco.
- 2 - Não utilize produtos químicos ou abrasivos.

**ATENÇÃO**

- 1 - Read and observe the entire instruction carefully before starting the assembly.
- 2 - The product must be assembled on a clean and flat surface. We advise you to use the packaging to cover the floor in order not to be scratched.

PESSOAS NECESSÁRIAS PARA A MONTAGEM DO PRODUTO  
**PEOPLE REQUIRED FOR ASSEMBLY**