









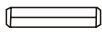

Ferragens / Herraje:

A	Parafuso 3,5 X 40 Tornillo 	24
B	Parafuso 3,5 x12 Tornillo 	76
C	Parafuso 3,5 x 30 Tornillo 	12
D	Cavilhas 6 x30 Tacos 	08
E	Cantoneira Esquinera 	08
F	Taxa 13 x 15 Clavo 	08
G	Taxa 10 x10 Clavo 	100
H	Suporte de Prateleira Apoyo de estanteria 	04
I	Dobradiça Bisagra 	10
J	Puxador Tirador 	06
L	Sapata 15 mm Zapata 	06
M	Suporte de Cabide Apoyo de percha 	02
N	Fixador Costas Fijador Espalda 	10
P	Corrediça Corrediza 	02

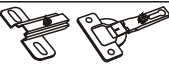
NUMERAÇÃO DE PEÇAS	
N°	DESCRIÇÃO
273	Lateral Esquerda / Lateral izquierda
272	Lateral direita / Lateral derecha
279	Tampo superior / Tapa superior
280	Tampo baixo / Tapa abajo 6 mm
281	Prateleira fixa / Estantería fija
257	Prateleira móvel / Estantería móvil
276	Frente Gaveta / Delantera cajón
122	Lateral gaveta / Lateral cajón
137	Trazeiro gaveta / Trazeiro cajón
135	Fundo gaveta / Fondo cajón
278	Roda-forro / Roda-forro
277	Rodapé pintado / Rodepié pintado
277	Rodapé traseiro / Rodapié trazero
306	Divisória / División
274	Porta grande / Puerta grande
275	Porta pequena / Puerta pequeña
752	Costas / Espalda

ACESSÓRIOS	
N°	DESCRIÇÃO
00086	Pau cabide
002397	Perfil H
2126	Puxador
2461	Corrediça
F 104-S/D	Kit Ferragem

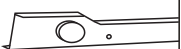
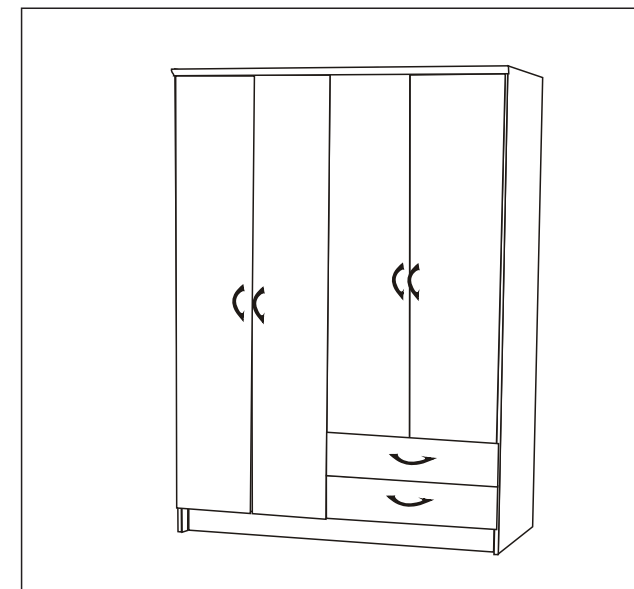

Martelo Chave Phillips Chave Fenda Trena Parafusadeira



Ferramentas necessárias (Não fornecidas)
Tools Required (Not Provided)
Herramientas necesarias (no incluidas)

2º Passo
2 paso

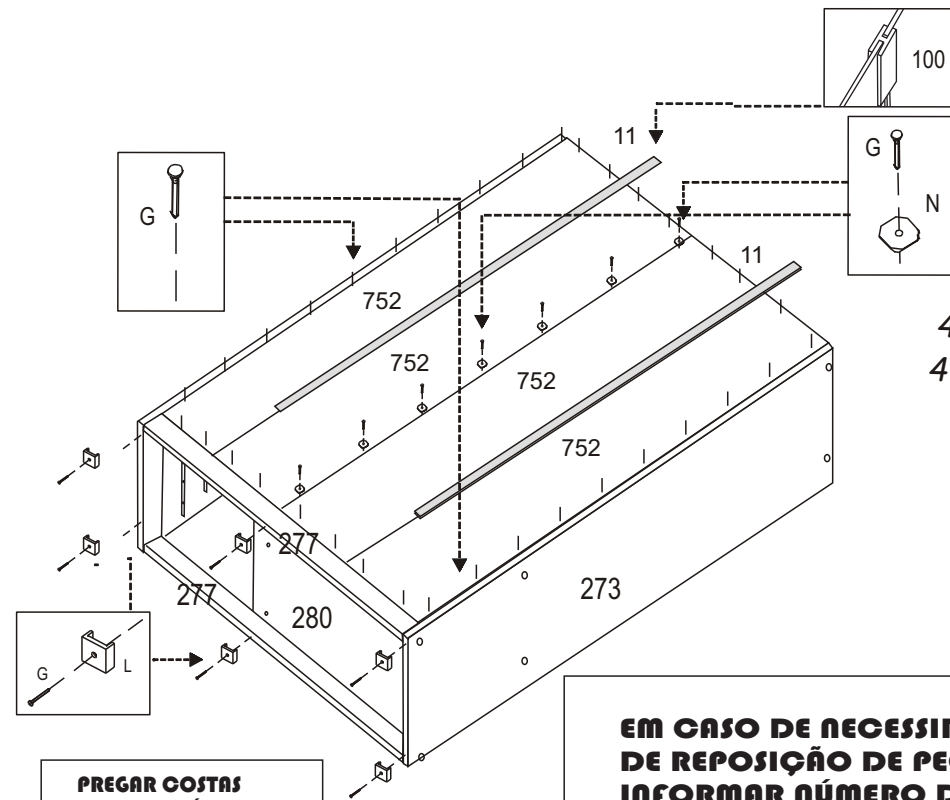
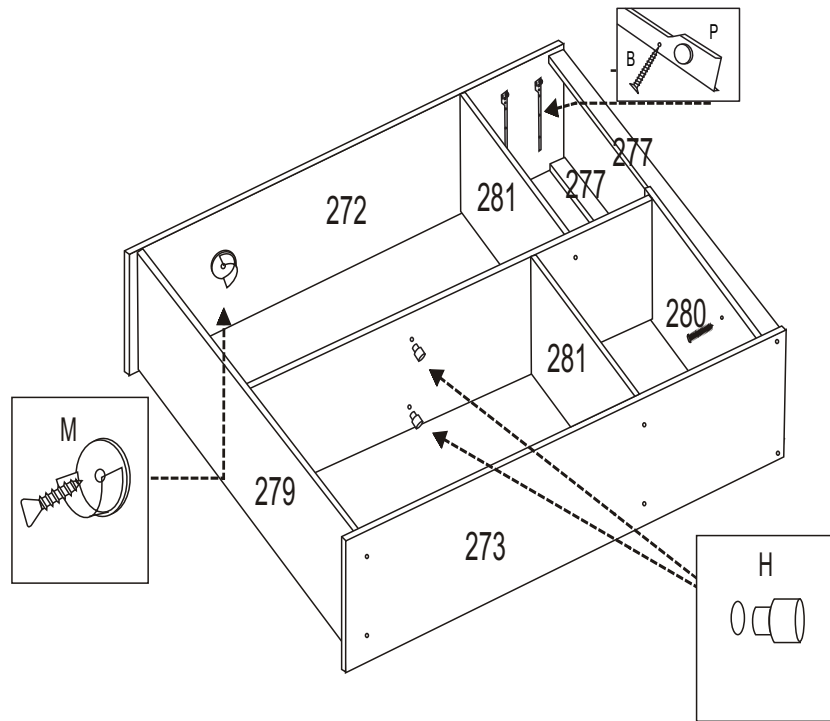

4º Passo
4 paso

Atenção com a cor do acabamento!
Em caso de assistência solicitar o código de acordo com a cor da peça/
Pay attention to the color of the finish!
In case of assistance request the code according to the color of the part/
Atención con el color del acabado!
En caso de asistencia solicitar el código de acuerdo con el color de la pieza.

PREGAR COSTAS
NO RODAPÉ TRAZEIRO
MELHOR FIXAR

**EM CASO DE NECESSIDADES
DE REPOSIÇÃO DE PEÇAS
INFORMAR NÚMERO DA PEÇA.
LOTE E BITOLA DA CHAPA.
EX: 12 MM.6MM OU 15 MM.**

1º Passo
1 paso

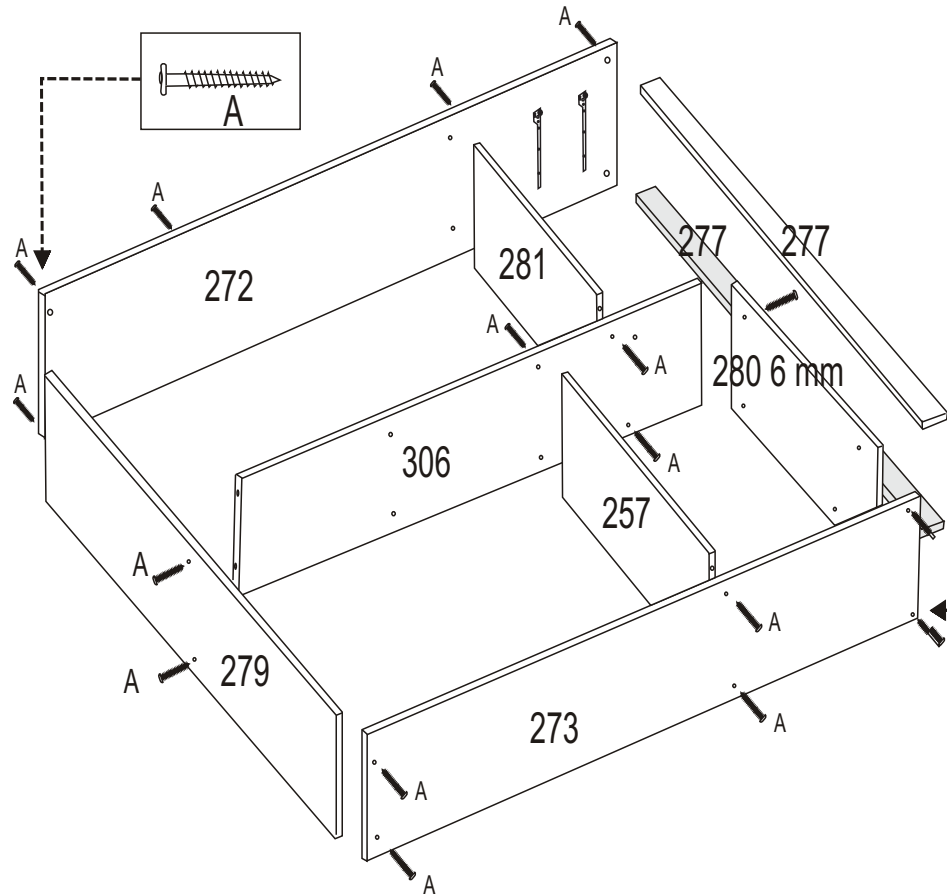

3º Passo
3 paso

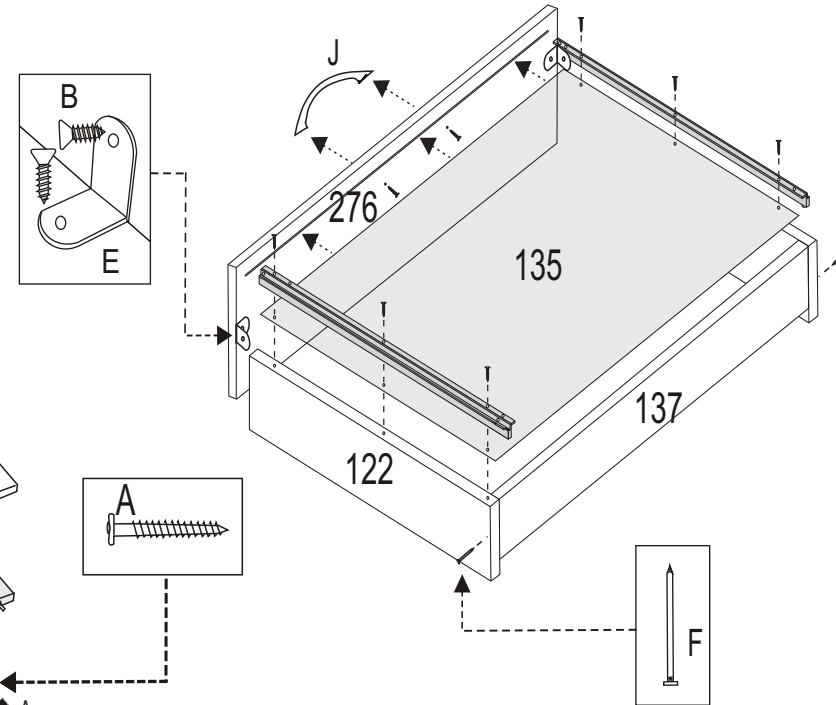

Atenção com a cor do acabamento!
Em caso de assistência solicitar o código de acordo com a cor da peça/
Pay attention to the color of the finish!
In case of assistance request the code according to the color of the part/
Atención con el color del acabado!
En caso de asistencia solicitar el código de acuerdo con el color de la pieza.

5º Passo
5 paso

6º Passo
6 paso

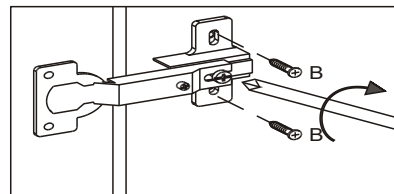
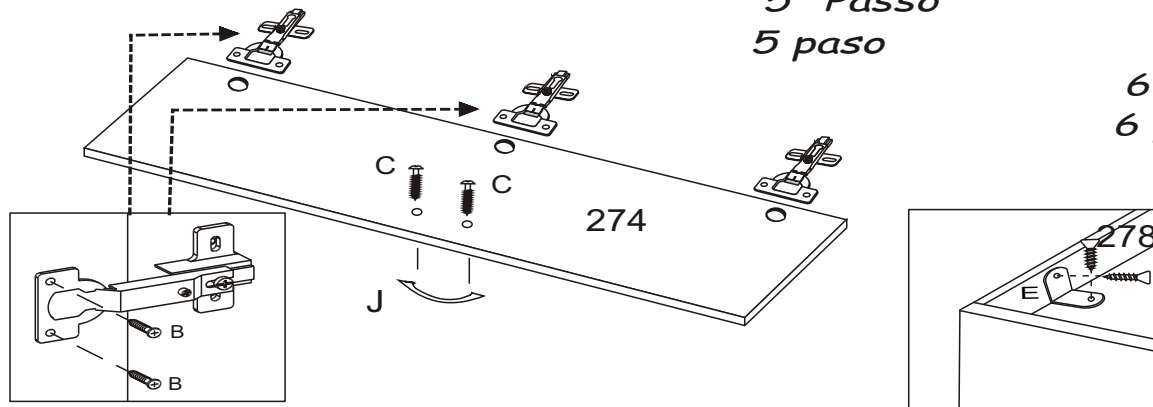

7º Passo
7 paso

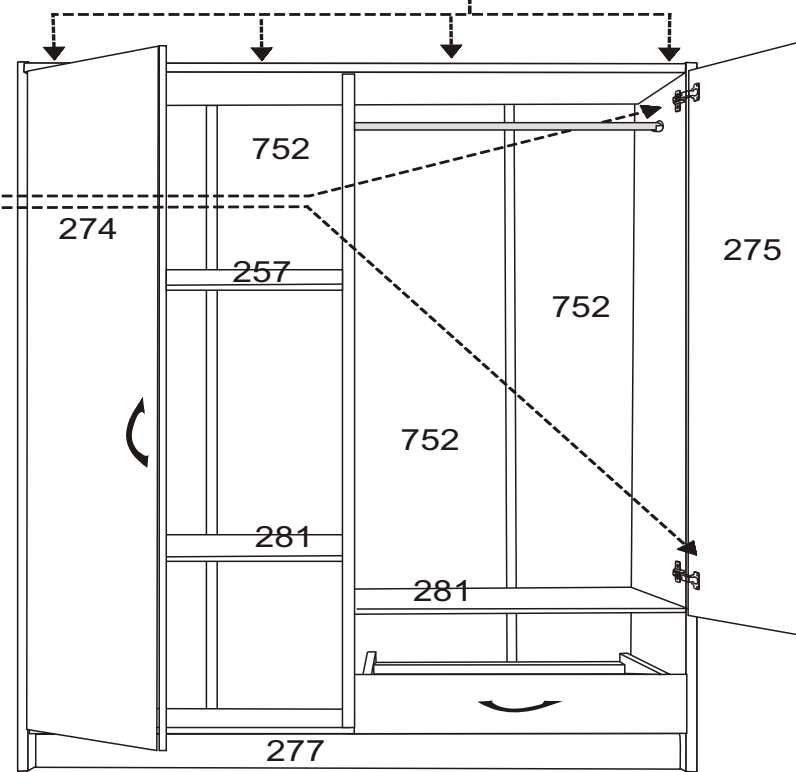

REGULAGEM / REGLAJE

