

Manual de montagem

Instrucciones de montaje Assembly instructions

R261

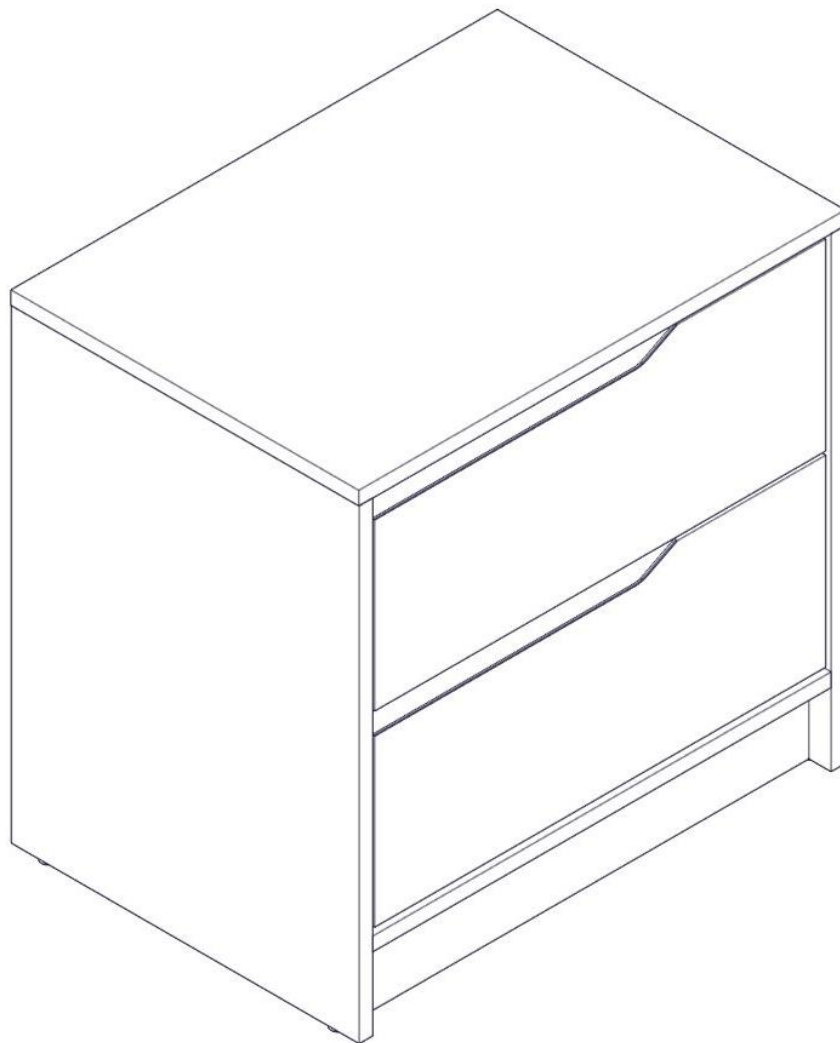

! Imagens meramente ilustrativas !
Imágenes ilustrativas/Images merely illustrative.

Dúvidas? Entre em contato:
Dudas? Ponerse em contacto:
Doubts? Get in touch:
(51) 3635-8839

A montagem deve ser efetuada por 2 pessoas.

El montaje debe ser efectuada por 2 personas.

The assembly must be done by 2 people.

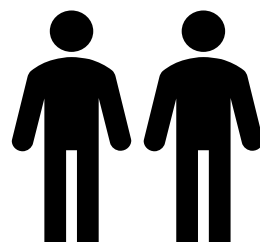

Ferramentas necessárias para montar o móvel.

Herramientas necesarias para armar el mueble.

Tools needed to assemble the furniture.



Dúvidas? Entrar em contato:

Dudas? Ponerse en contacto:

Doubts? Get in touch:

Fone: (51) 3635-8839

www.kappesberg.com.br



Montar o móvel sobre uma superfície limpa e plana.

Armar el mueble sobre una superficie limpia y plana.

Assemble the furniture on a clean, flat surface.

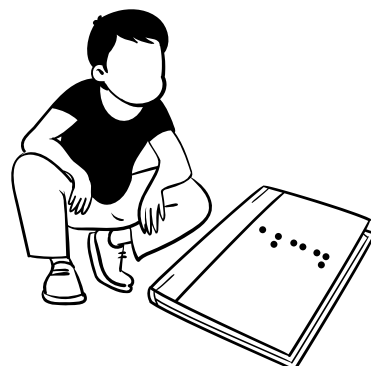

**IDENTIFICAÇÃO DAS PEÇAS / IDENTIFICACIÓN DE LAS PIEZAS PARTS
IDENTIFICATION**

QTD.	CÓDIGO / CODE	DESCRIÇÃO	Descripción	Description	C x L x E	L x W x T
1	P105231	TAMPO	TAPA	TOP	537 x 384 x 15 mm	21.14 x 15.12 x 0.59 in
1	P105232	BASE	BASE	BASE	506 x 384 x 15 mm	19.92 x 15.12 x 0.59 in
1	P105233	LATERAL ESQUERDA	LADO EZQUIERDA	LEFT SIDE	515 x 384 x 15 mm	20.28 x 15.12 x 0.59 in
1	P105234	LATERAL DIREITA	LADO DERECHA	RIGHT SIDE	515 x 384 x 15 mm	20.28 x 15.12 x 0.59 in
2	P105235	RODAPE	ZOCALO	BASEBOARD	506 x 80 x 15 mm	19.92 x 3.15 x 0.59 in
1	P105236	COSTA	COSTA	COAST	526 x 439 x 3 mm	20.71 x 17.28 x 0.12 in
2	P105237	LATERAL DE GAVETA DIREITA	LADO DERECHO DEL CAJÓN	DRAWER RIGH SIDE	350 x 120 x 15 mm	13.78 x 4.72 x 0.59 in
2	P105238	LATERAL DE GAVETA ESQUERDA	LADO ESQUIERDO DEL CAJÓN	LEFT DRAWER SIDE	350 x 120 x 15 mm	13.78 x 4.72 x 0.59 in
2	P105239	FUNDO DE GAVETA	FONDO DEL CAJÓN	DRAWER BOTTOM	463 x 348 x 3 mm	18.23 x 13.70 x 0.12 in
2	P105241	CABECEIRA DE GAVETA	CABEZAL DEL CAJÓN	DRAWER HEAD	451 x 120 x 15 mm	17.76 x 4.72 x 0.59 in
2	P105243	FRENTE DE GAVETA	FRENTE DEL CAJÓN	DRAWER FRONT	498 x 203 x 18 mm	19.61 x 7.99 x 0.71 in

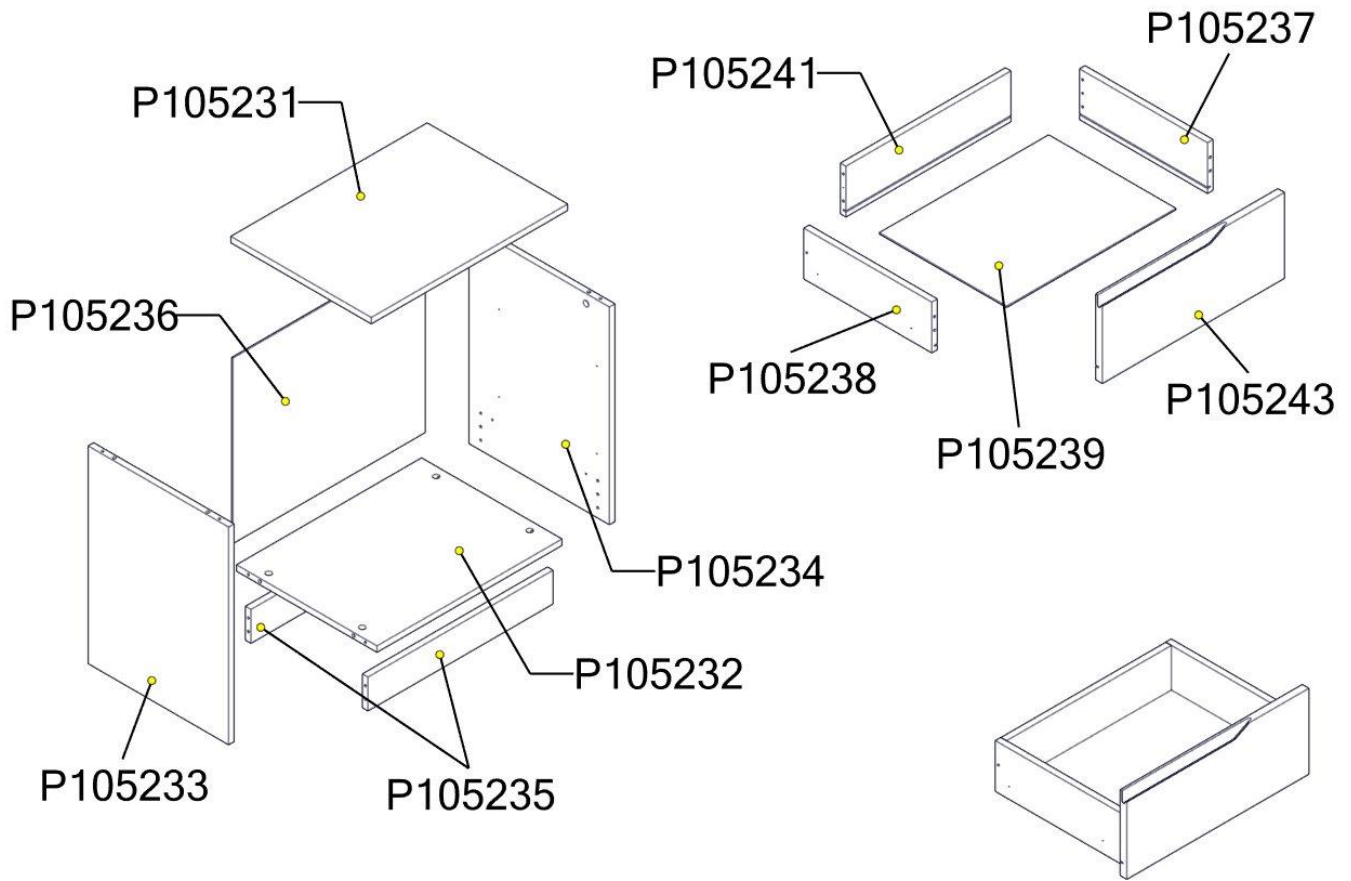

IDENTIFICAÇÃO DOS ACESSÓRIOS / IDENTIFICACIÓN DE ACCESORIOS
IDENTIFICATION OF ACCESSORIES



NOTAS: A separação dos acessórios antes de iniciar a montagem facilitará a mesma. Em caso de dúvida na identificação, coloque o acessório sobre a régua.

Nota: Separar los accesorios antes de iniciar el montaje facilitará el mismo. En caso de duda en la identificación, coloque el accesorio en la regla.

NOTE: Separating the accessories before starting assembly will make it easier. In case of doubt in the identification, place the accessory on the ruler.

	QTD.	CÓDIGO / CODE	DESCRIÇÃO	Descripción	Description
	1	000041	COLA BRANCA	SOBRE DE COLA	GLUE
	18	000107	PREGO 10 X 10	CLAVO 10 X 10	NAIL 10 X 10
	4	000108	PREGO 12 X 12	CLAVO 12 X 12	NAIL 12 X 12
	4	000226	P.CHATO 4,0 X 40 CAB. PHILLIPS ZB/BC	TORNILLO 4X40MM	SCREW 4X40MM
	8	000899	CANTONEIRA PLASTICA PRETA	CANTONERA	PLASTIC SUPPORT
	32	001802	CAVILHAS DE MADEIRA 6X30 PINUS	TARUGO 6X30MM	DOWEL 6X30MM

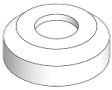
IDENTIFICAÇÃO DOS ACESSÓRIOS / IDENTIFICACIÓN DE ACCESORIOS IDENTIFICATION OF ACCESSORIES

	4	001901	SAPATA DESLIZADORA PRETA 15 X 6	ZAPATO 15 X 6	SHOE 15 X 6
	56	004214	P.CHATO 3,5 X 14 CAB. PHILLIPS REBAIXADA ZB	TORNILLO 3,5 X 14MM	SCREW 3,5 X 14MM
	4	005256	P.CHATO 4,0 X 20 CAB. PHILLIPS ZB/BC	TORNILLO PLANO 4,0 X 20 BC	FLAT SCREW 4,0 X 20 BC
	4	018458	SUPORE TRIANGULAR PRETO	SOPORTE TRIANGULO	TRIANGLE SUPPORT
	8	030945	PARAFUSO DE ACO P/ MINIFIX	TORNILLO DE ACERO PARA MINIFIX	STEEL SCREW FOR MINIFIX
	8	030950	TAMBOR P/ MINIFIX 15MM ZAMAQ 09.11.007	CILINDRO 15MM	BARREL 15MM
	2	CRTM350X30	CORREDICA TELESCOPICO MINI LIGHT 350MM	SISTEMA DE CAJONES DESILZANTES	SLIDING DRAWER SYSTEM

INSTALAÇÃO MINIFIX

Identificar seta no corpo do tambor de minifix. A seta DEVE apontar para o buraco na borda do painel. Empurrar o tambor até o buraco.

INSTALACIÓN DE LA LEVA

Identifique la flecha en la cabeza de la leva. La flecha DEBE apuntar hacia el orificio del borde del panel. Empuje la leva hasta el fondo del orificio.

INSTALLING CAM

Identify arrow on head of cam. Arrow MUST point toward hole in edge of panel. Push cam all the way down into hole.

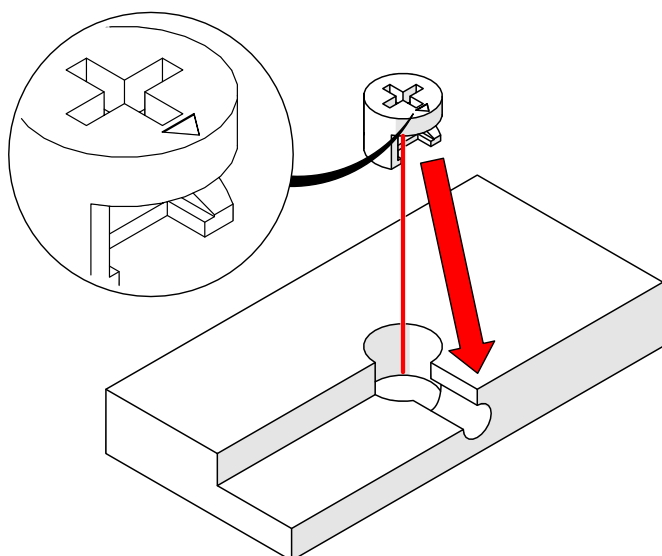

ALINHAMENTO DO TAMBOR E PARAFUSO

A seta do tambor de minifix deve ser aponta para o buraco e inserir o parafuso do minifix do tambor contido no buraco. Certifique-se de que as peças se unam.

ALINEACIÓN DE LA LEVA Y EL PASADOR

Asegúrese de que la flecha de la leva apunte hacia el orificio e inserte la clavija de la leva en el orificio. Asegúrese de que las piezas se unen.

CAM AND DOWEL ALIGNMENT

Ensure the arrow on the cam points toward hole and insert cam dowel into hole. Make sure pieces join together.

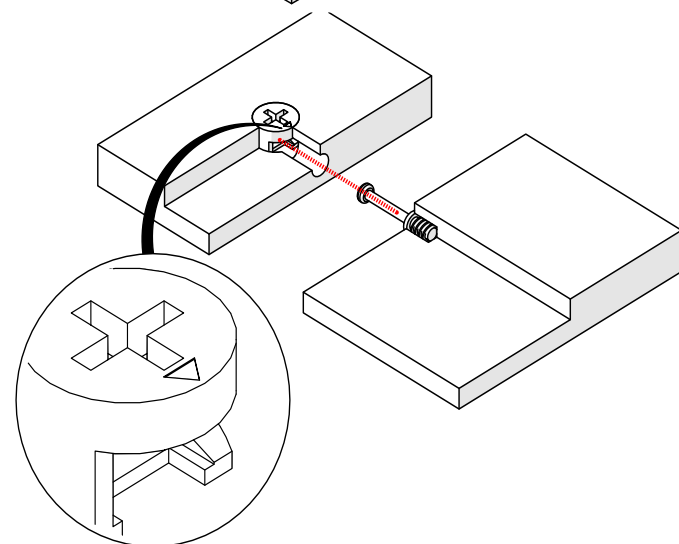

CÂMARA DE COMPENSAÇÃO DE TENSÃO

Use uma chave de fenda para girar a came. Girar o tambor minifix (no sentido horário) até que esteja totalmente apertado. Ligeiramente mais de meia volta.

APRIETE DE LA LEVA

Utilice un destornillador para girar la leva. Gire la leva (en el sentido de las agujas del reloj) hasta que esté completamente apretada. Un poco más de media vuelta.

TIGHTENING CAM

Use screwdriver to turn cam. Turn cam (clockwise) until fully tightened. Slightly more than half a turn.

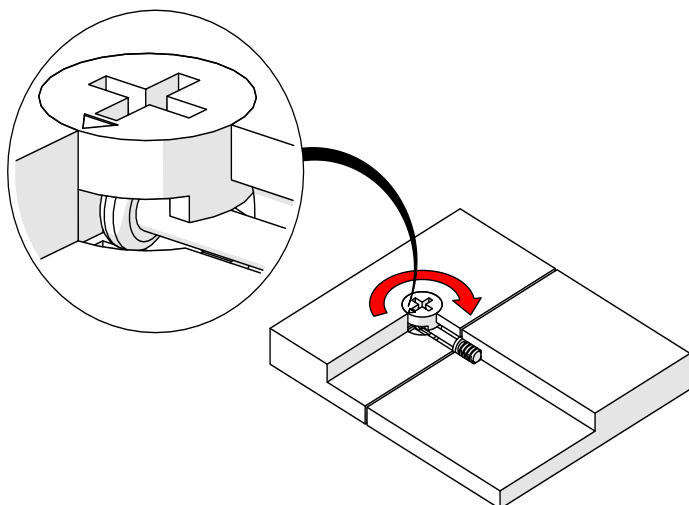

PASSO / PASO / STEP 1

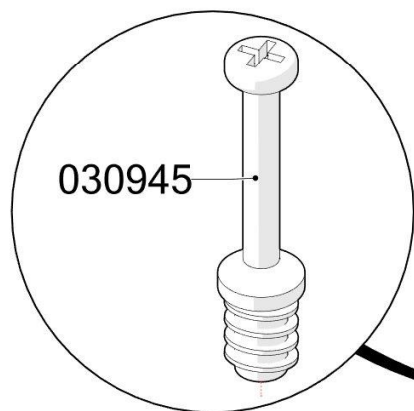

Cód.	Qtde.
030945	4

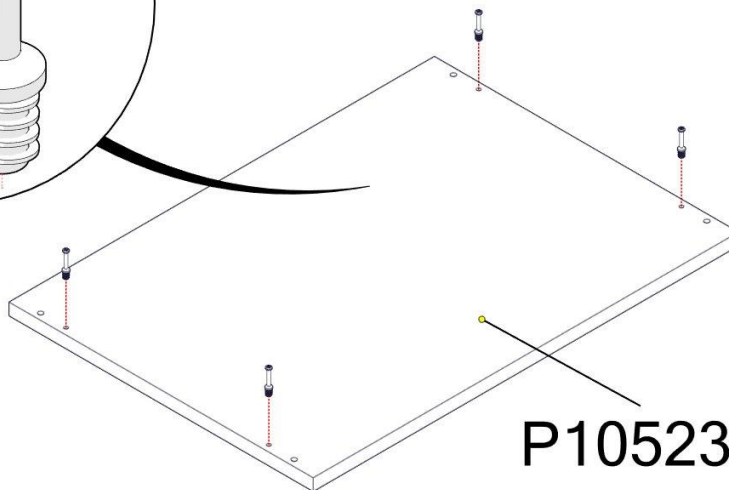

PASSO / PASO / STEP 2

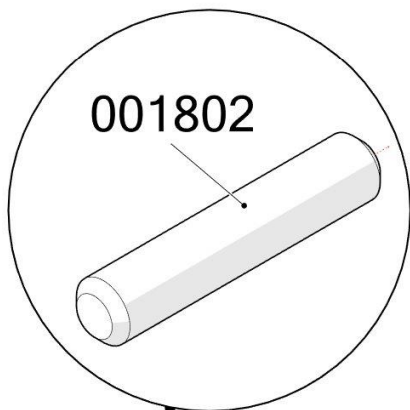

Cód.	Qtde.
001802	4

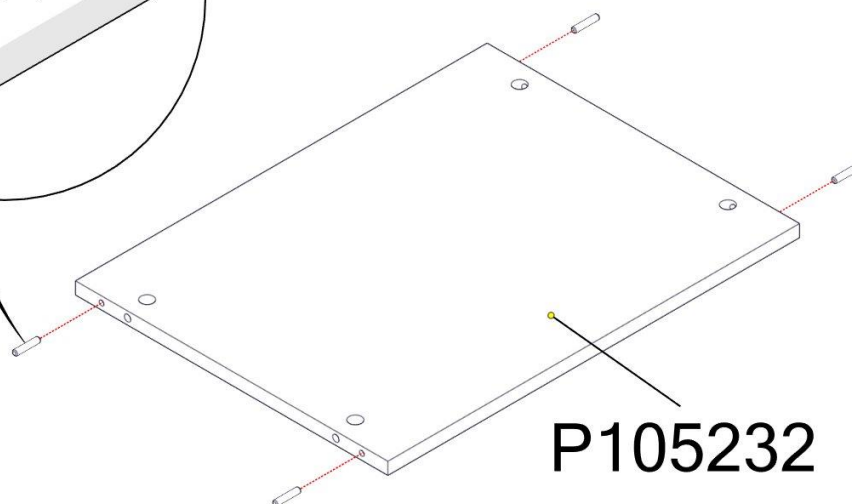

PASSO / PASO / STEP 3

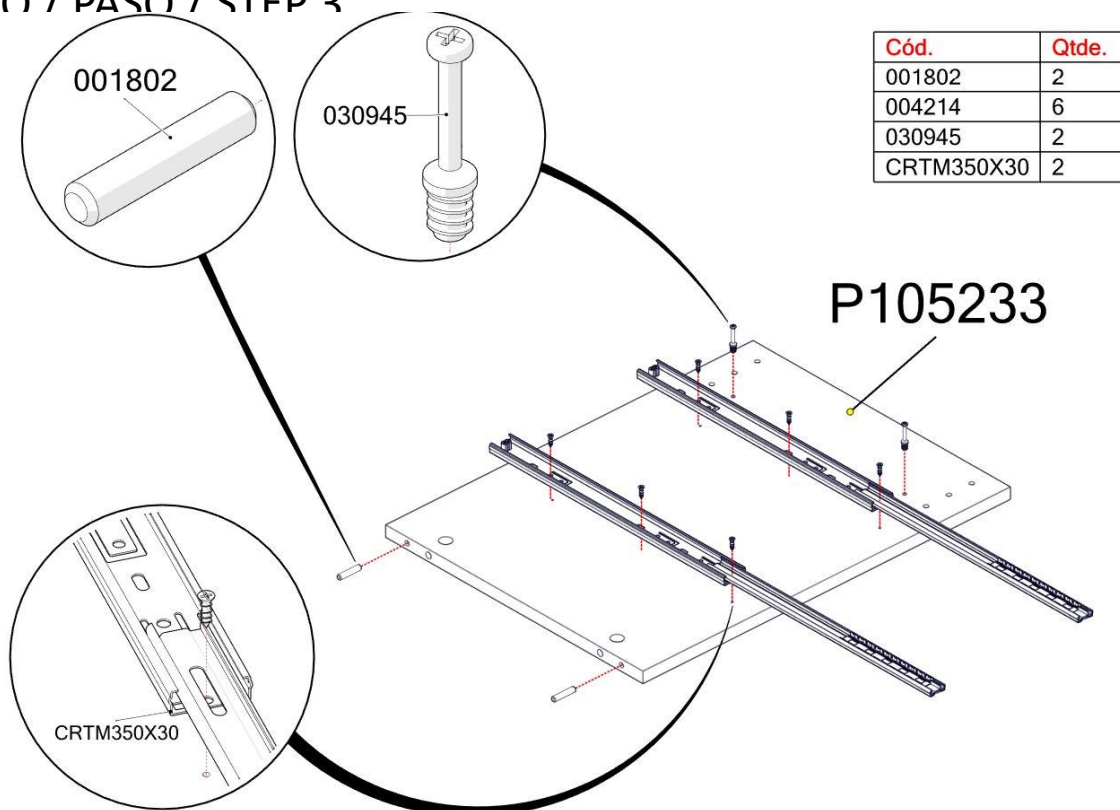

PASSO / PASO / STEP 4

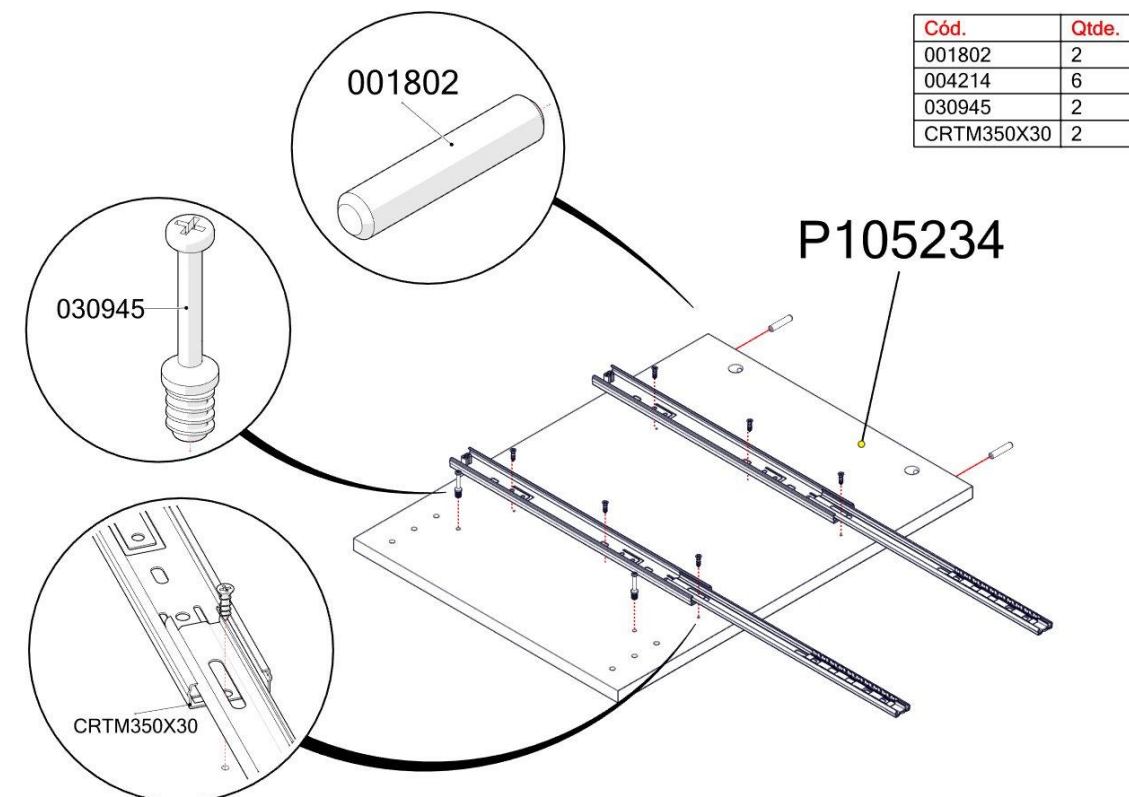

PASSO / PASO / STEP 5

Cód.	Qtde.
001802	8

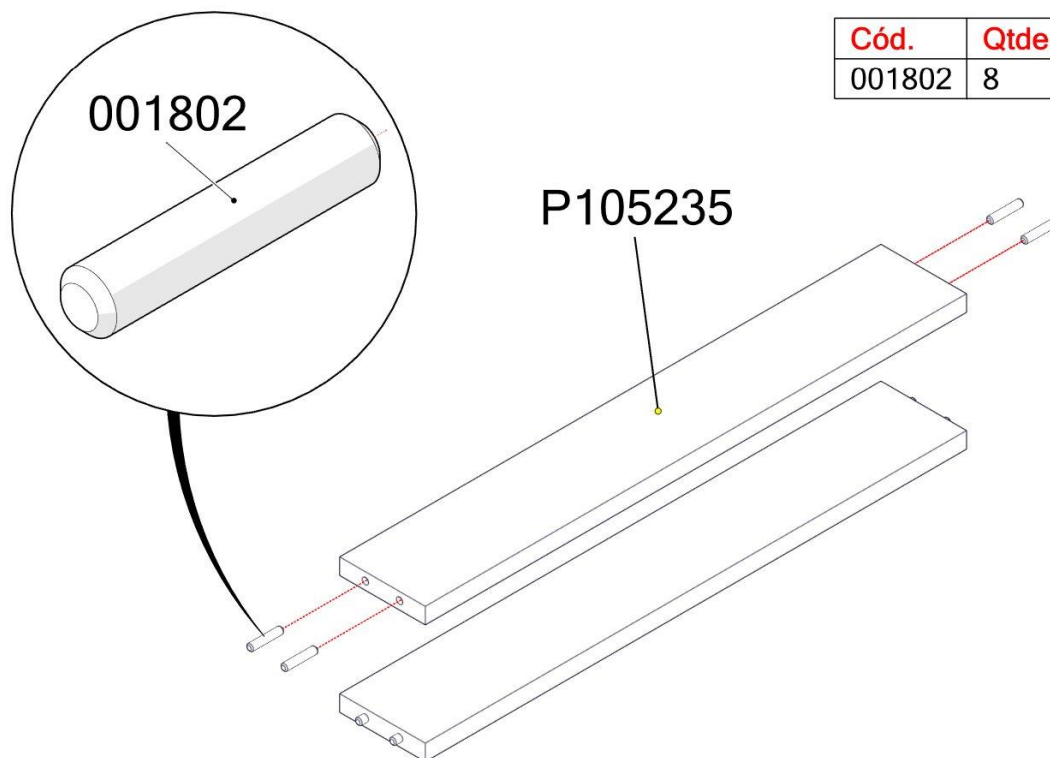

PASSO / PASO / STEP 6

Cód.	Qtde.
001802	4

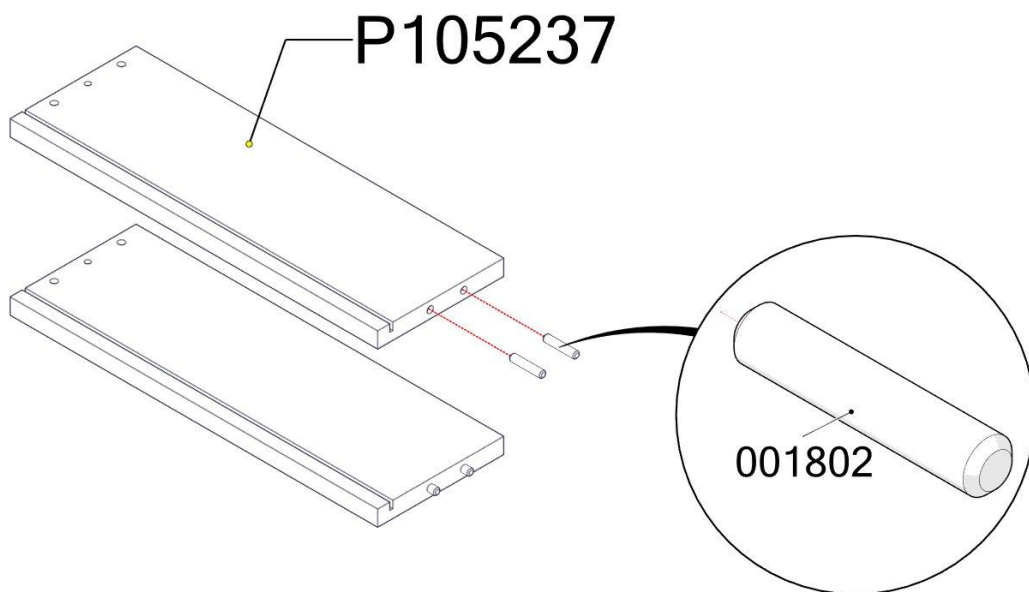
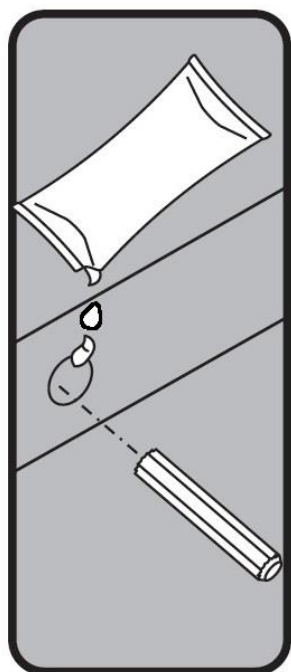

PASSO / PASO / STEP 7

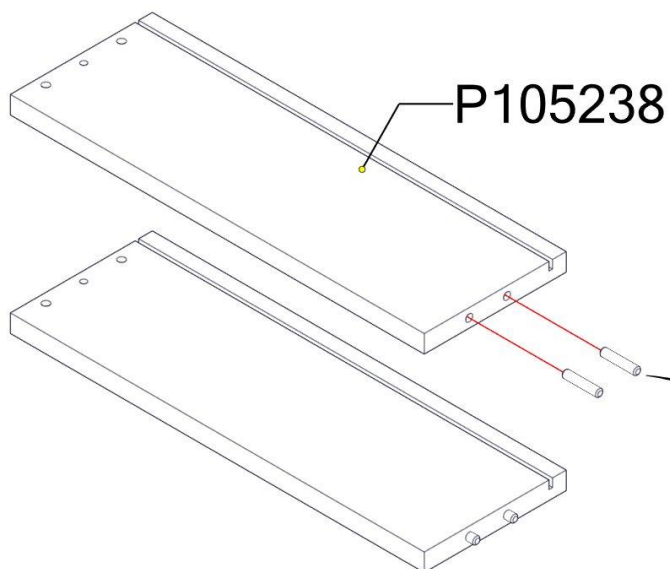
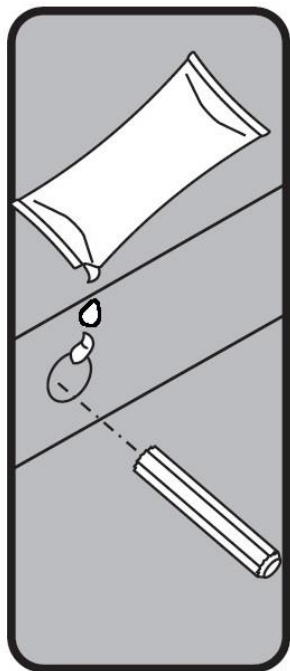

Cód.	Qtde.
001802	4

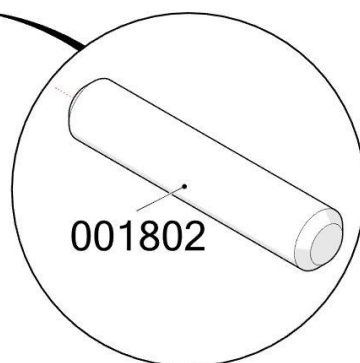

PASSO / PASO / STEP 8

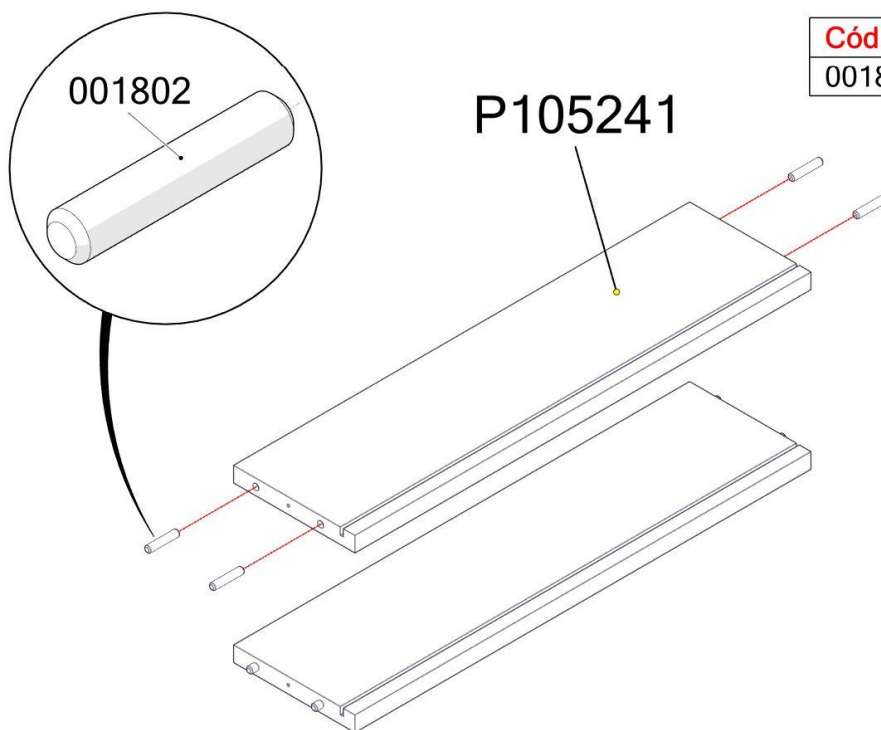
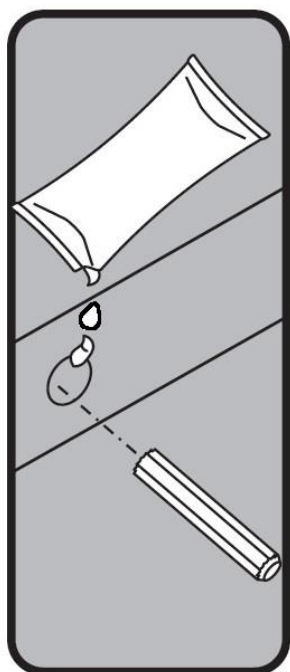

Cód.	Qtde.
001802	8

PASSO / PASO / STEP 9

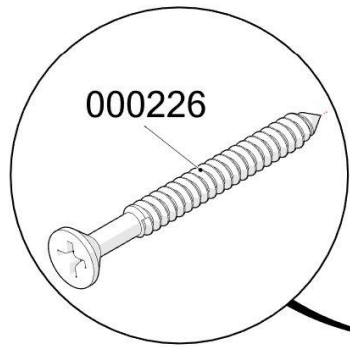

Cód.	Qtde.
000226	4

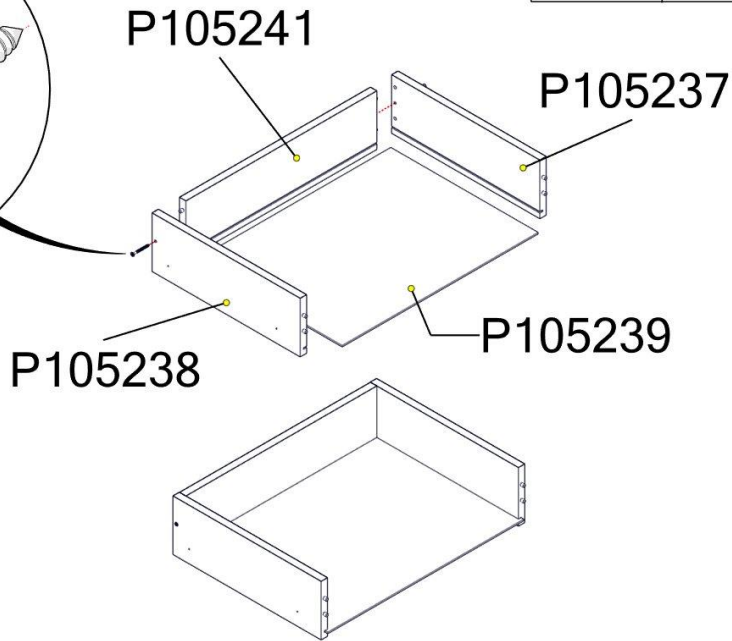

PASSO / PASO / STEP 10

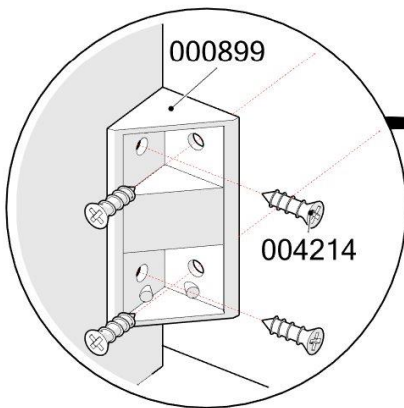

Cód.	Qtde.
000899	4
004214	16

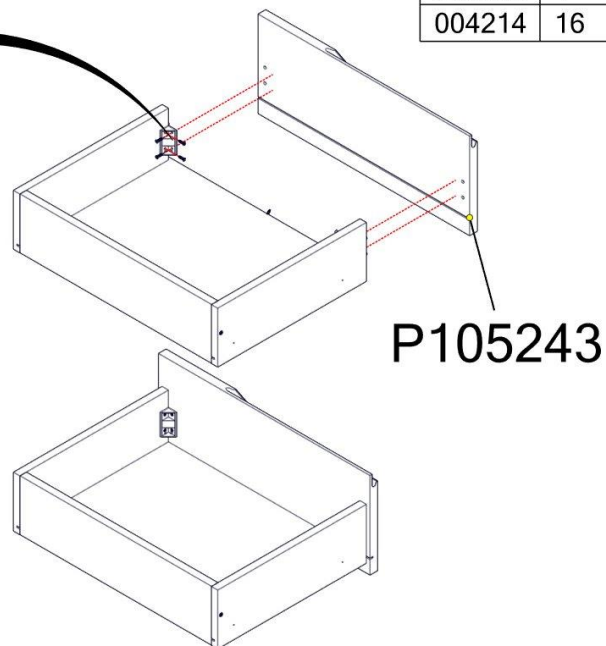

PASSO / PASO / STEP 11

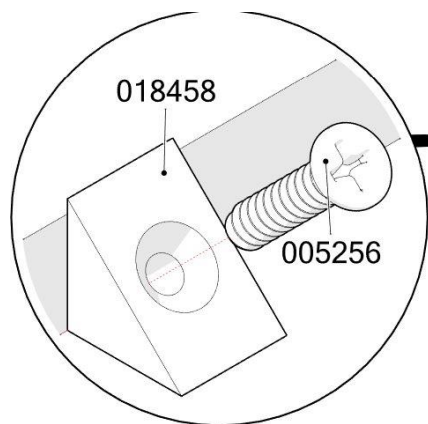

Cód.	Qtde.
005256	4
018458	4

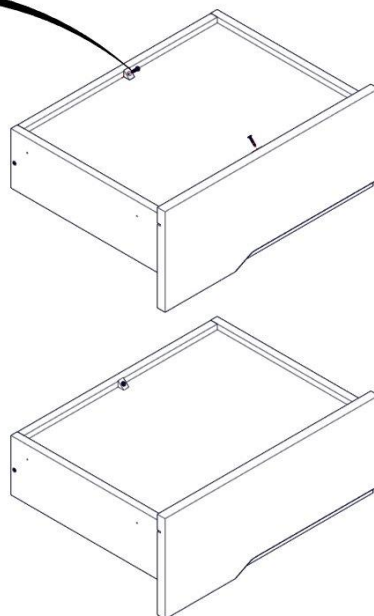

PASSO / PASO / STEP 12

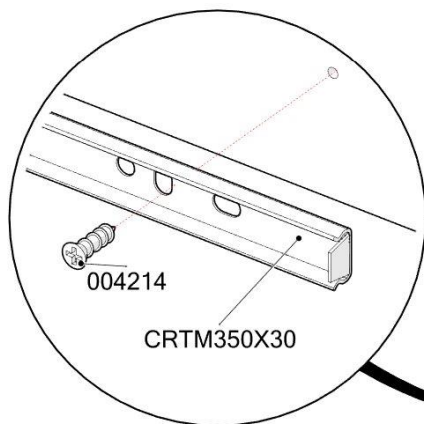

Cód.	Qtde.
004214	12
CRTM350X30	4

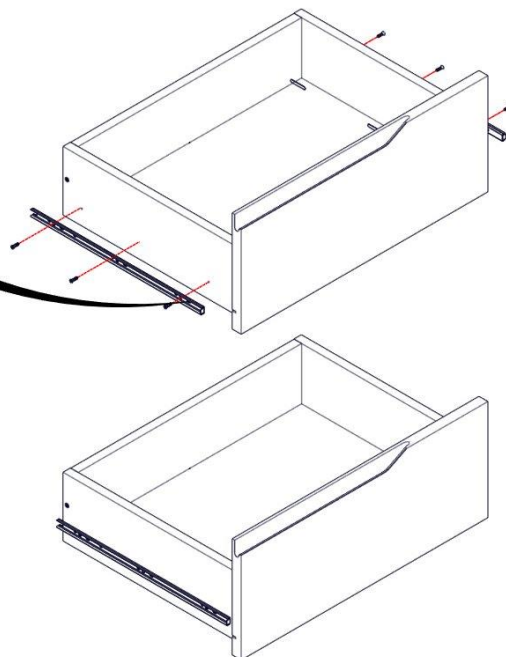

PASSO / PASO / STEP 13

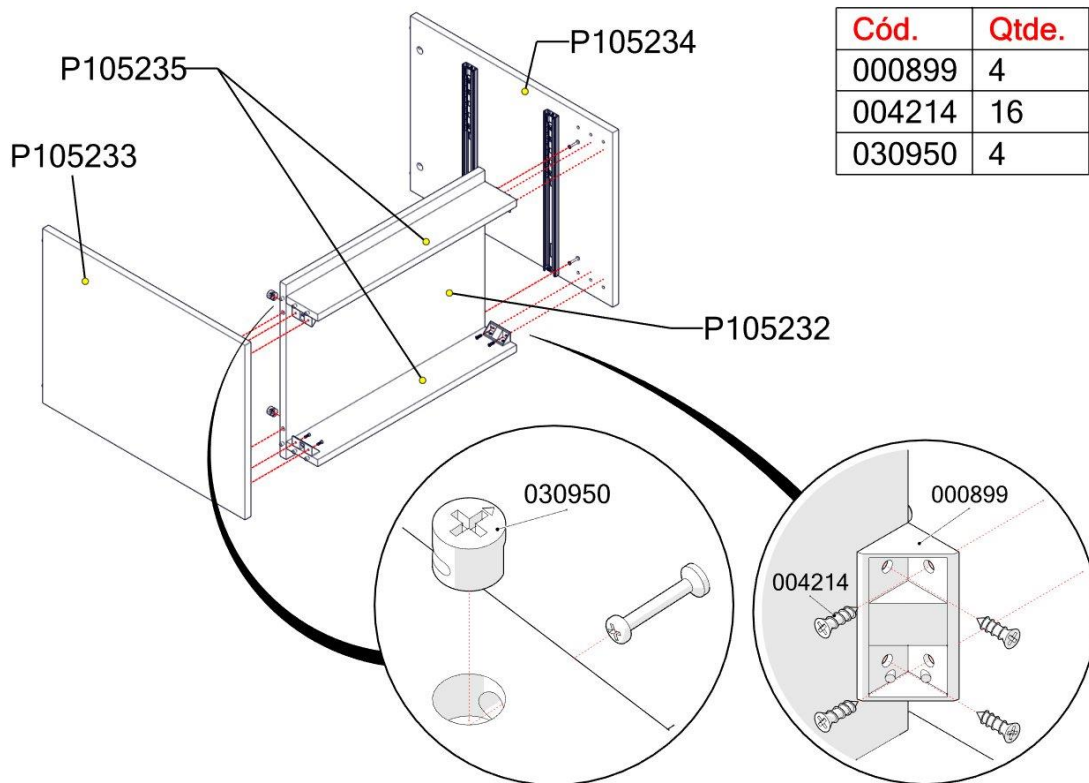

Cód.	Qtde.
000899	4
004214	16
030950	4

PASSO / PASO / STEP 14

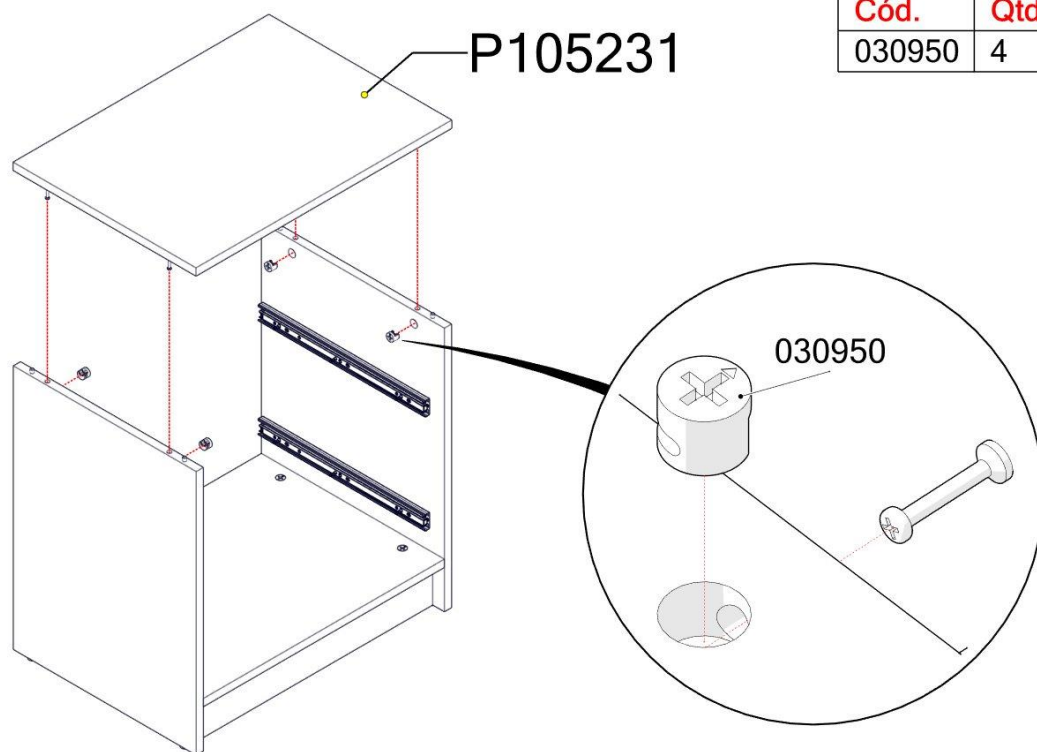

Cód.	Qtde.
030950	4

PASSO / PASO / STEP 15

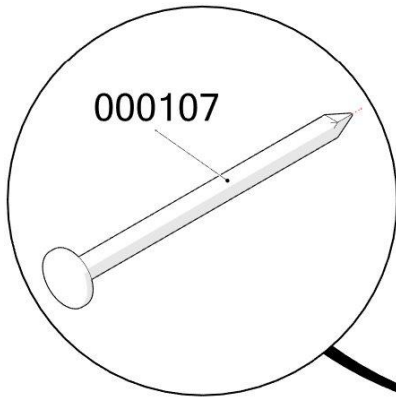

Cód.	Qtde.
000107	18

P105236

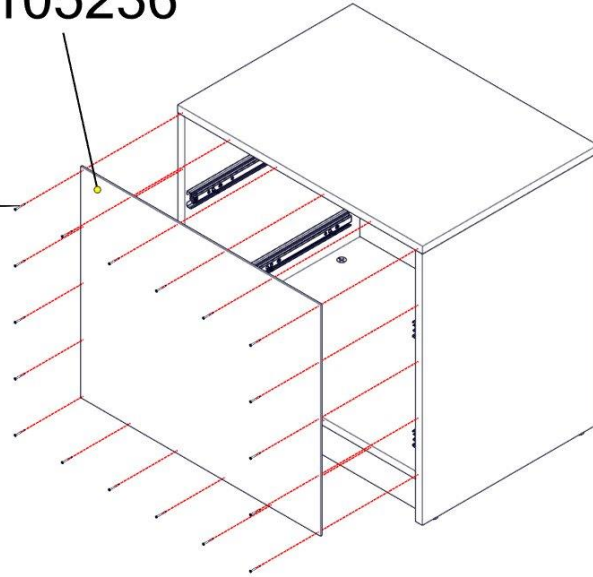

PASSO / PASO / STEP 16

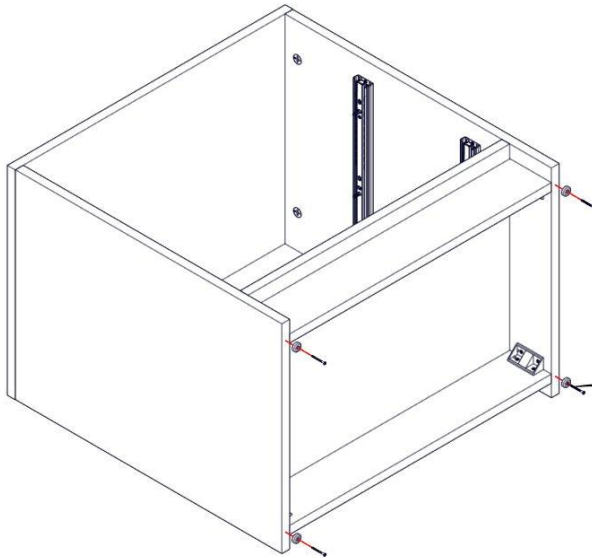

Cód.	Qtde.
000108	4
001901	4

