



CRIADO RETRÔ PLUS

ATENÇÃO/ ATTENTION / ATENCION

VÍDEO DE MONTAGEM DISPONÍVEL NO SITE / ASSEMBLY VIDEO AVAILABLE ON THE SITE
VÍDEO DE MONTAJE DISPONIBLE EN EL SITIO

www.olivar.com.br

DIMENSÕES DO PRODUTO / PRODUCT DIMENSIONS / DIMENSIONS PRODUCT - WxDxH / LxDxA - 425 X 388 X 667MM

ATENÇÃO/ ATENCION/ ATTENTION

ESTE PRODUTO NÃO PODE SER ARRASTADO.
THIS PRODUCT MUSTNOT BE DRAGGED.
ESTE PRODUCTO NO SE PUEDE ARRASTRAR

PEÇAS NUMERADAS/ NUMBERED PARTS/
PIEZAS NUMERADAS

EX: 1915X-X 125(peça/ piece/ pieza number)

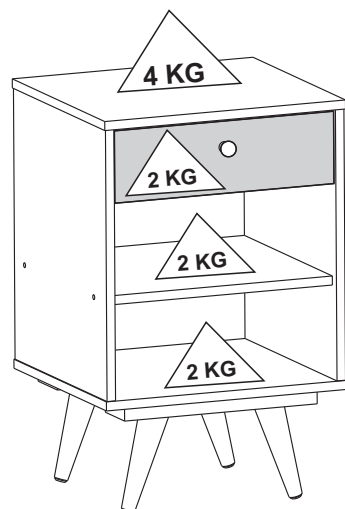

Vídeo de Montagem
Assembly video
Vídeo de Montaje

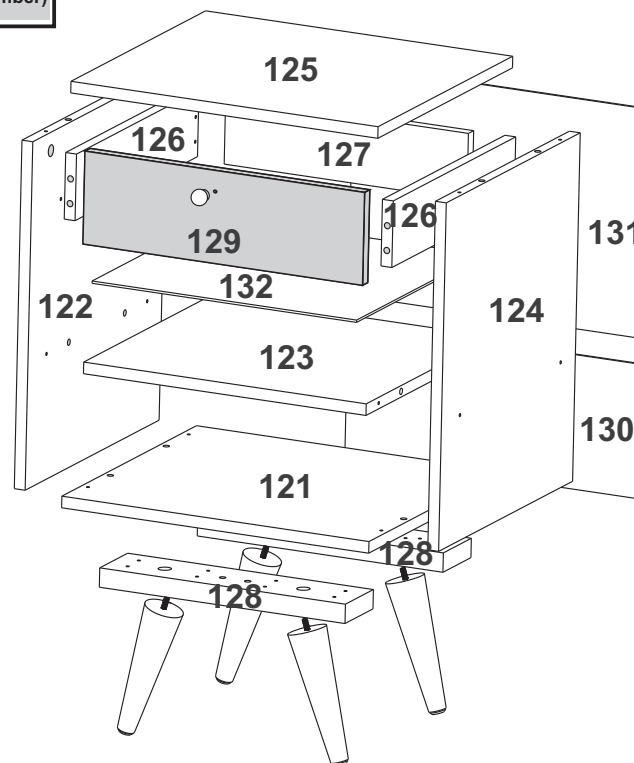

CUIDADOS ESPECIAIS

LIMPEZA- Pano limpo umedecido em água e sabão neutro.
BRILHO- Fлана seca.

SPECIAL CARE

CLEANING-Clean cloth moistened with water and mild soap.
SHINE- Dry cloth.

CUIDADOS ESPECIALES:

LIMPIEZA- Paño limpio humedecido con agua y un jabón suave.
BRIGHT- Fлана seco.

ATENÇÃO / ATTENTION / ATENCION

Nunca utilizar óleos, lustra móveis; produtos abrasivos, saponáceos, esponja de aço e outros.

Never use oils, polish furniture , abrasive products, soaps, steel sponge and others.

Nunca use aceites, pulimentos; abrasivos, jabones, esponja de acero y otros.

MONTAR O PRODUTO SOBRE A EMBALAGEM,
EVITANDO DANOS NA PINTURA.
ACONSELHAMOS QUE A MONTAGEM DO PRODUTO
SEJA POR UM PROFISSIONAL.

SETUP THE PRODUCT ON TOP OF THE PACKAGING, AVOIDING
DAMAGE TO THE PAINT.
WE RECOMMEND THAT THE INSTALLATION IS DONE BY
A PROFESSIONAL.

MONTAR EL PRODUCTO EN EL PAQUETE,
EVITAR LESIONES EN PINTURA.
AVISAMOS QUE EL MONTAJE DEL PRODUCTO
SEA UN PROFESIONAL.

Ferramentas necessárias / Necessary tools / Herramientas Necesarias
(não fornecidas) (not provided) (No proporcionadas)

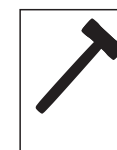
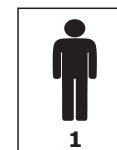

**MEDIDA UTILIZADA EM MM /
UNIT MEASURE USED IS MILLIMETERS (MM)**

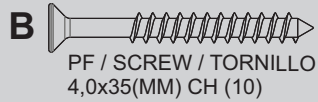
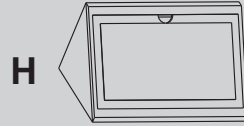

CANTONEIRA / PLASTIC CORNER /
ESQUINA PL 20X20X42 (MM) (02)

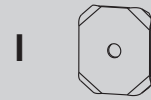

GARRA /
JONT METAL PLATE
EMBRAGUES (04)

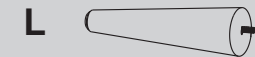
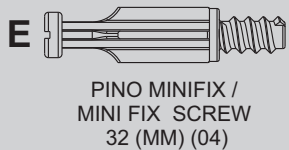
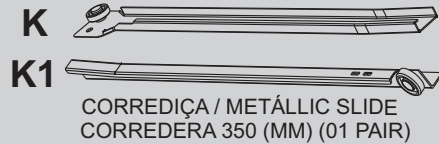
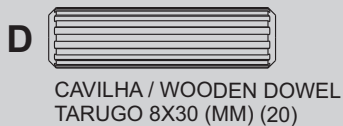

PÉ PALITO C/ HASTE/ WOODEN LEG
WITH STEM / PIES PALLILO MADERA
C/ VARILLA 170(MM) (04)



TAMBOR MINIFIX /
MINI FIX ROUND NUT
15 (MM) (04)

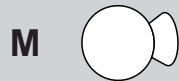

PUXADOR MADEIRA/
WOOD HANDLER/ MANIJA MADERA (01)



ITEM		DESCRIÇÃO DA PEÇAS / DESCRIPTION OF PARTS / UNIT MEASURE USED IS MILLIMETERS (MM)				CORES / COLORS / COLORES			
COD. CODE	Nº	NOME/NAME/NOMBRE	MEDIDAS / MEASURES (MM)	TIPO TYPE	QUANT AMOUNT CANTIDAD	BCO WHITE BLANCO	PRETO BLACK NEGRO	TURQ	RUSTIK
10126	121	BASE	425X385X15	MDP	01	121/05	121/07		121/24
10127	122	LAT. ESQ./ LEFT SIDE/ LADO IZQUIERDO	450X383X15	MDP	01	122/05	122/07		122/24
10128	123	PRATELEIRA/ SHELF/ ESTANTE	391X366X15	MDP	01	123/05	123/07		123/24
10129	124	LAT. DIR./ RIGHT SIDE./ LADO DERECHO	450X383X15	MDP	01	124/05	124/07		124/24
10130	125	TAMPO/ TOP	425X385X15	MDP	01	125/05	125/07		125/24
10131	126	LAT.GAV.ESQ.DIR/LEFT/RIGHT DRAW. SIDE/LAD. CAJ.IZQ.DER.	350X86X15	MDP	02	126/05	126/07		126/24
10133	127	CONT. FRENT. GAV./FRONT AGAINST DRAWER	336X86X15	MDP	01	127/05	127/07		127/24
10206	128	REFOR. PÉ/ FOOT REINFORCEMENT/ REFUERZO PIE	340X80X25	MDF	02	128/05	128/07		128/24
11090	129	FRENTE GAV./ DRAWER FRONT/ FRENTE DEL CAJÓN	387X120X15	MDP	01	129/21	129/07	129/21	129/24
10135	130	FUNDO TRÁS / BACK / TRASEIRO	410X173X3	TRI	01	130/05	130/07		130/24
10136	131	FUNDO TRÁS / BACK / TRASEIRO	410X296X3	TRI	01	131/05	131/07		131/24
10137	132	FUNDO GAV. / DRAWER BACKGROUND/ FONDO CAJON	358X366X3	TRI	01	132/05	132/07		132/24
438	A	PF. / Screw / Tornillo 4,0x40(MM) CH			12				
437	B	PF./ Screw / Tornillo 4,0x35(MM)			10				
986	C	PF./ Screw/ Tornillo 3,5x14(MM) CRR			20				
137	D	Cavilha / Wooden Dowel / Tarugo 8x30(MM)			20				
532	E	Pino Minifix /Minifix Screw 32(MM)			04				
508	F	Tambor Minifix / Minifix Round Nut 15(MM)			04				
7687	G	Tapa Furo / Cover Cap 8(MM)			04	BCO	PTO		CAFÉ
10006	H	Cantoneira PL/Plast. corner with lid / Esquina PL. 20X20X42(MM)			02	BCO	PTO		CAFÉ
911	I	Garra/ Jont Metal Plate/ Embragues			04				
248	J	Prego / Nail / Clavo 8x8(MM)			30				
139	K	Corred./Metallic Slid 350(MM) (01 Pair)			01				
10203	L	Pé Palito Mad. c/ haste/ Wooden Leg 170 (MM) wiht stem/ Pies Pallilo Madera c/varilla			04		MEL		
10365									CAST
10207							MOGNO		
11132	M	Puxador madeira/Wool handle/ Manija Madera			01		HAYA		TABACO
11135									
13687							MOGNO		
8233	N	PF./ Screw/ Tornillo 3,5x25(MM) FL			01				
15203	O	Porca Garra de aço/ Steel Claw Nut/ Tuerca de Garra de Acero			04				
		Certif. de Garant./ Warranty Certif.			01				

**FIXAR PINO DE MINIFIX, TAMBOR E TAMPA /
FIXING THE MINIFIX PIN, DRUM AND MINIFIX COVER
COLOQUE EL PINO E TAMBOR MINIFIX Y LA TAMPA**

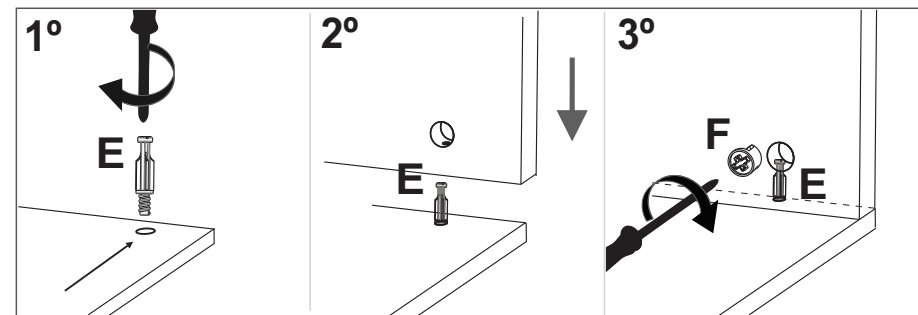

1 Obs: As peças pintadas nos passos são apenas ilustrativas.
The parts painted in the steps are illustrative only.
Las partes pintadas en los pasos son solo ilustrativas.

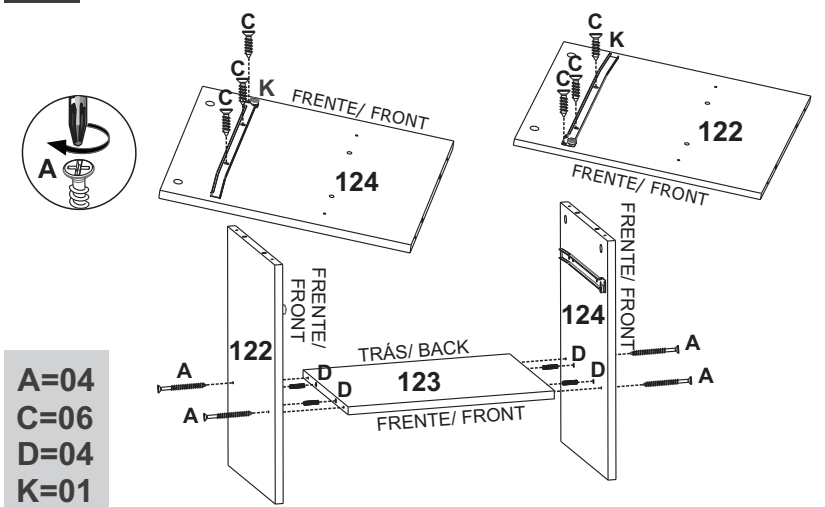

A=04
C=06
D=04
K=01

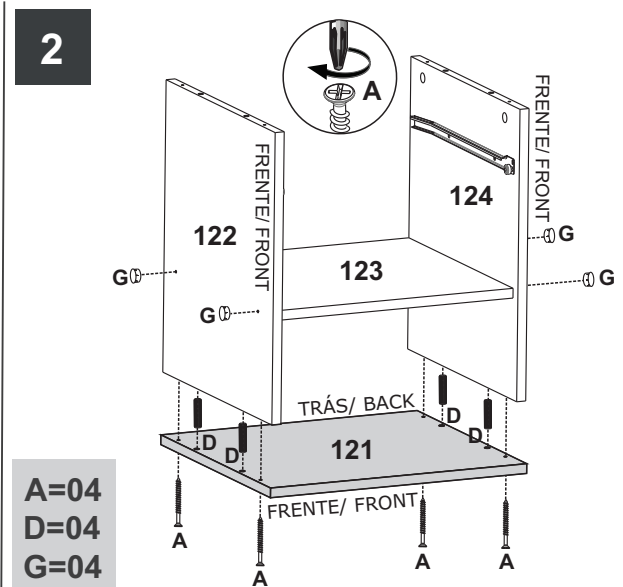
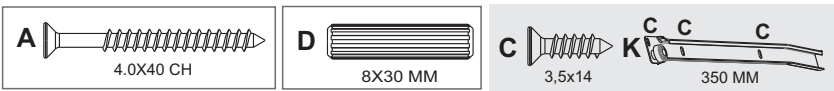

A=04
D=04
G=04

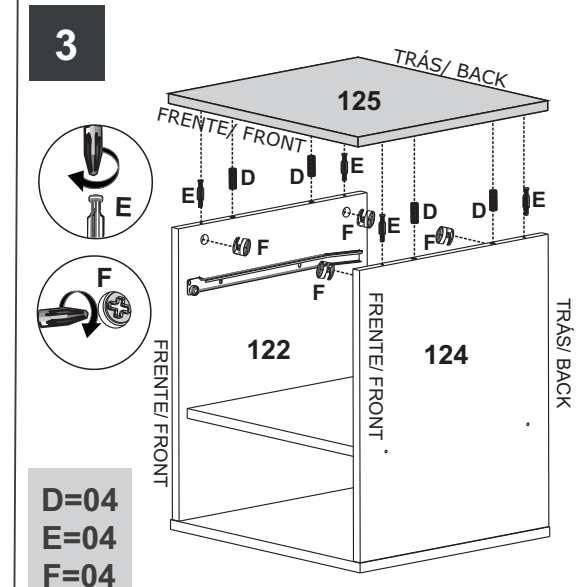
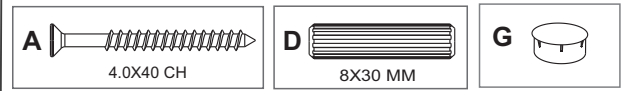

D=04
E=04
F=04

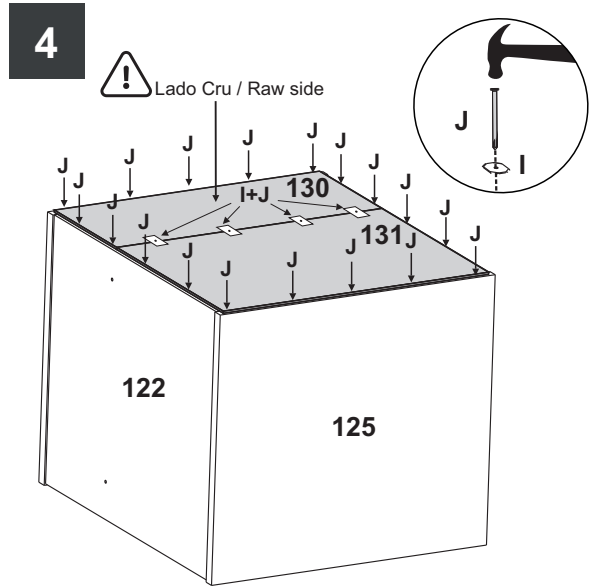

I=04
J=26

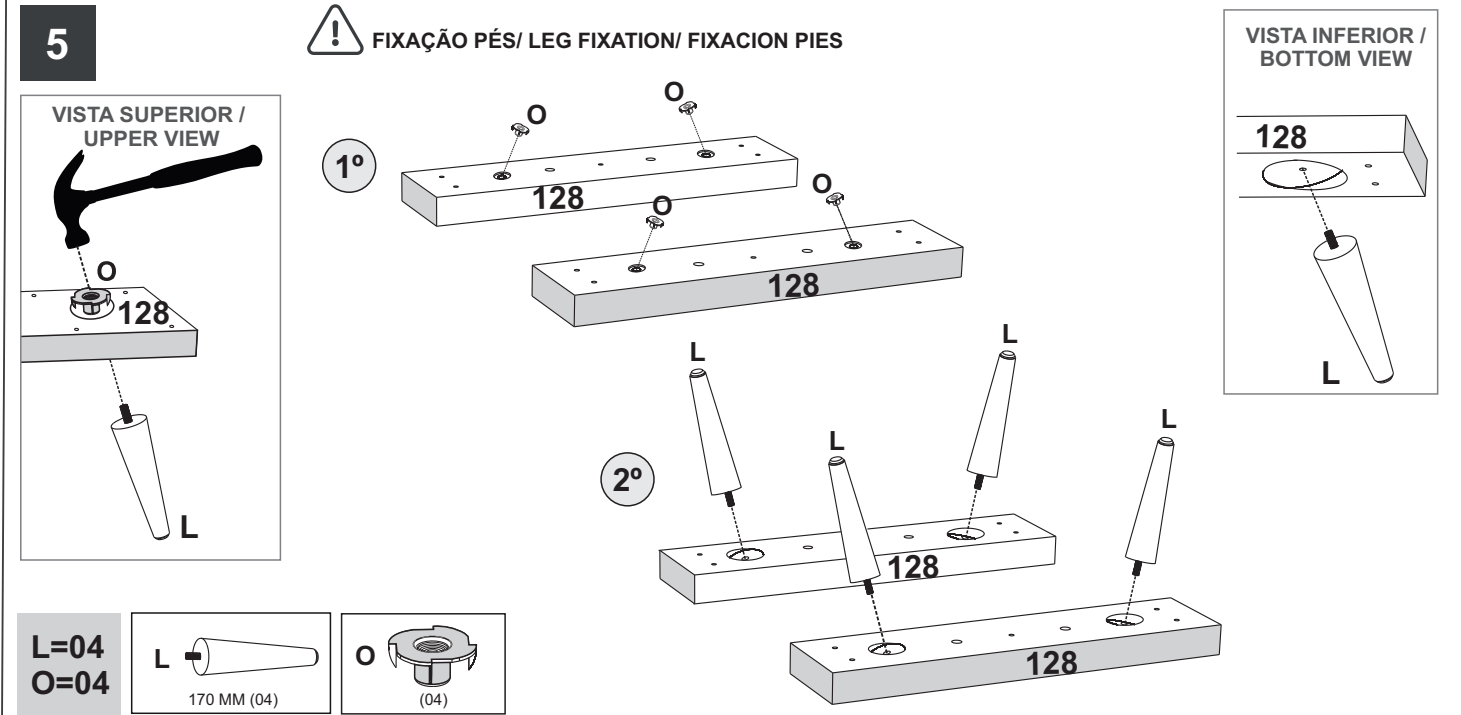

L=04
O=04

6

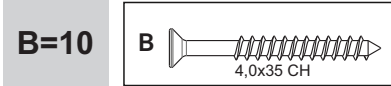
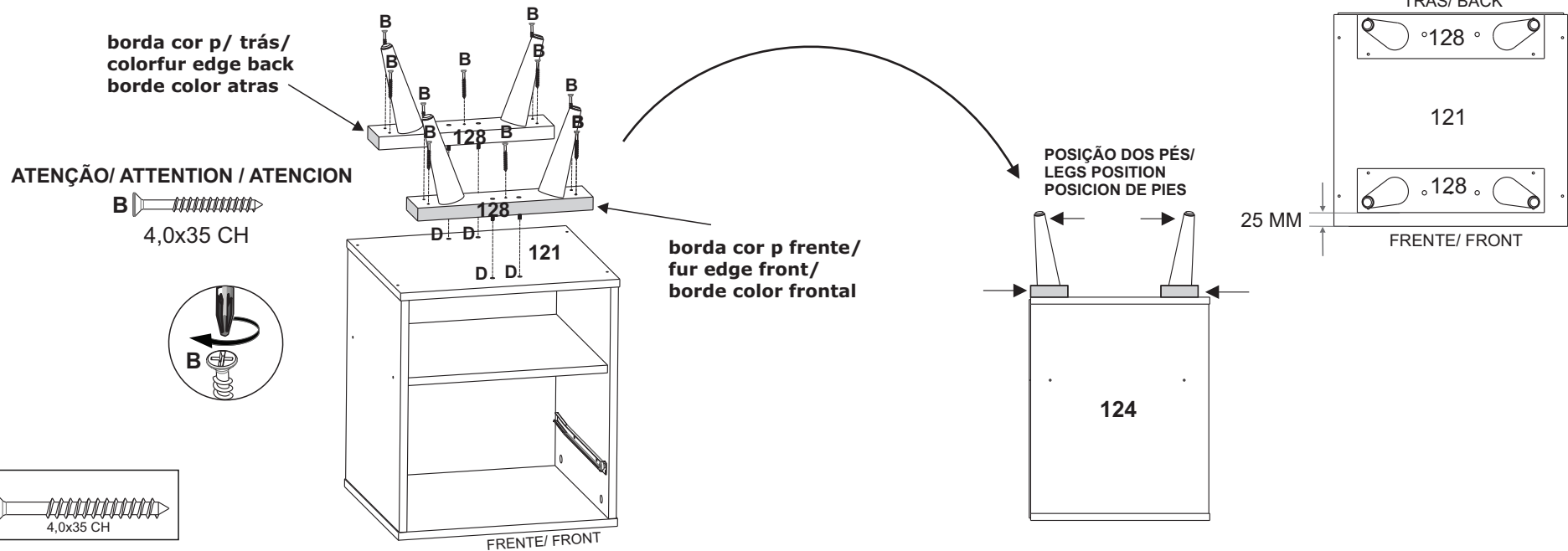

7

MONTAGEM GAVETA / ASSEMBLY OF THE DRAWER / MONTAJE LE CÁJON

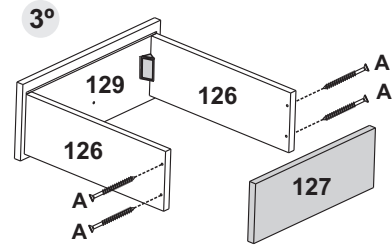
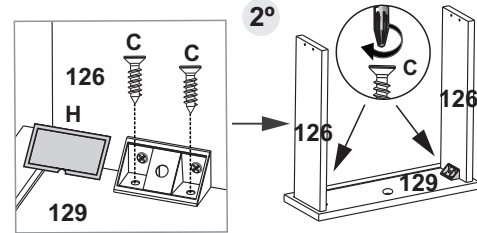
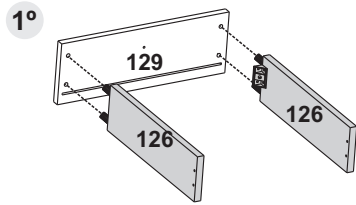
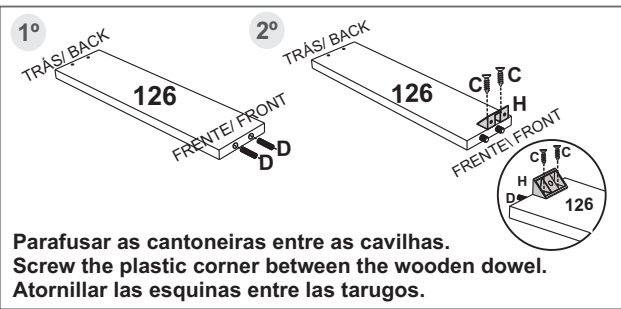

- A=04
- C=14
- D=04
- H=02
- J=04
- K1=01
- M=01
- N=01

