



MESA CABECEIRA RETRÔ VERSALHES

www.olivar.com.br

DIMENSÕES DO PRODUTO / PRODUCT DIMENSIONS / DIMENSIONS PRODUCT - WxDxH / LxDxA - 425 X 388 X 663 MM

ATENÇÃO/ ATENCION/ ATTENTION

ESTE PRODUTO NÃO PODE SER ARRASTADO.
THIS PRODUCT MUSTNOT BE DRAGGED.
ESTE PRODUCTO NO SE PUEDE ARRASTRAR.

PEÇAS NUMERADAS/ NUMBERED PARTS/
PIEZAS NUMERADAS

EX: 1915X-X 125 (peça/ piece/ pieza number)

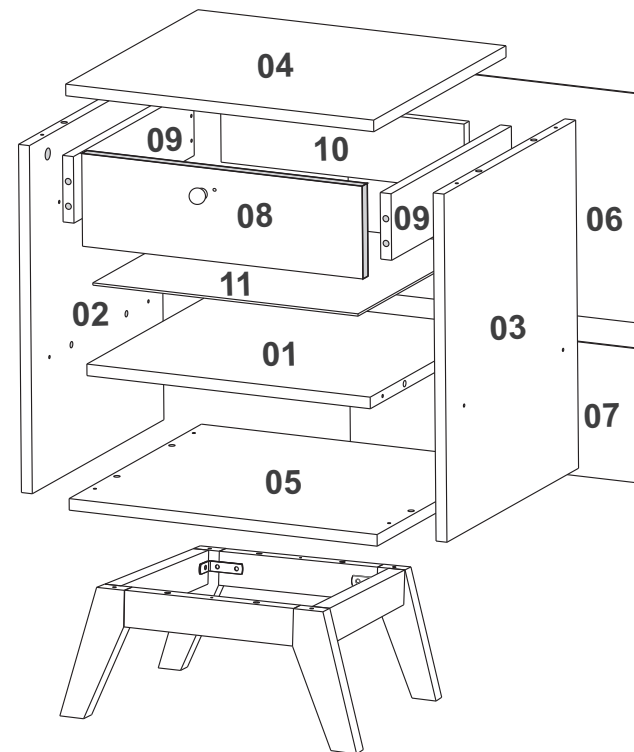
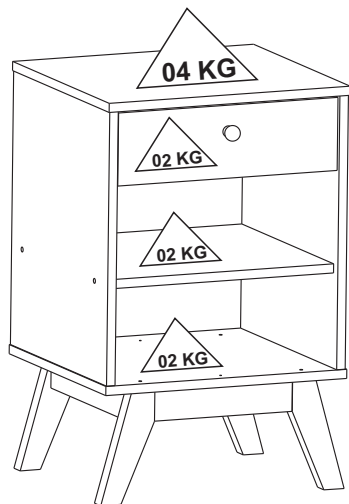

CUIDADOS ESPECIAIS

LIMPEZA- Pano limpo umedecido em água e sabão neutro.
BRILHO- Flanela seca.

SPECIAL CARE

CLEANING-Clean cloth moistened with water and mild soap.
SHINE- Dry cloth.

CUIDADOS ESPECIALES:

LIMPIEZA- Paño limpio humedecido con agua y un jabón suave.
BRIGHT- Flanela seco.

ATENÇÃO / ATTENTION / ATENCION

Nunca utilizar óleos, lustra móveis; produtos abrasivos, saponáceos, esponja de aço e outros.

Never use oils, polish furniture , abrasive products, soaps, steel sponge and others.

Nunca use aceites, pulimentos; abrasivos, jabones, esponja de acero y otros.

MONTAR O PRODUTO SOBRE A EMBALAGEM,
EVITANDO DANOS NA PINTURA.
ACONSELHAMOS QUE A MONTAGEM DO PRODUTO
SEJA POR UM PROFISSIONAL.

SETUP THE PRODUCT ON TOP OF THE PACKAGING, AVOIDING
DAMAGE TO THE PAINT.
WE RECOMMEND THAT THE INSTALLATION IS DONE BY
A PROFESSIONAL.

MONTAR EL PRODUCTO EN EL PAQUETE,
EVITAR LESIONES EN PINTURA.
AVISAMOS QUE EL MONTAJE DEL PRODUCTO
SEA UN PROFESIONAL.

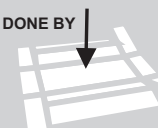

Ferramentas necessárias / Necessary tools / Herramientas Necesarias
(não fornecidas) (not provided) (No proporcionadas)

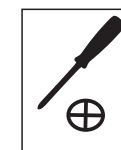
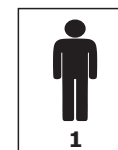

MEDIDA UTILIZADA EM MM / UNIT MEASURE USED IS MILLIMETERS (MM)

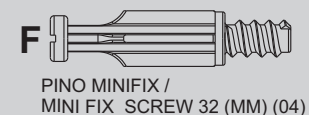
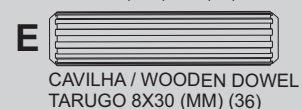

TAMBOR MINIFIX / MINI FIX ROUND NUT 15 (MM) (04)



TAPA FURO/ HOLER STIKER/ TAPA AGUGERO 8 MM (04)

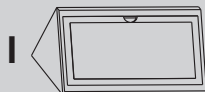

CANTONEIRA / PLASTIC CORNER / ESQUINA PL 20X20X42 (MM) (02)

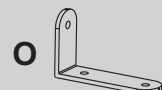
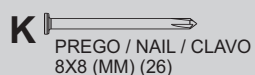
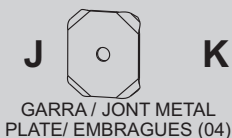

CANTONEIRA/ PLASTIC CORNER/ ESQUINA PL 20X20X42 (MM) (04)

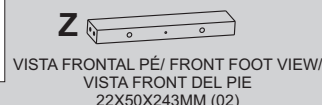
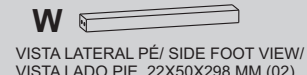
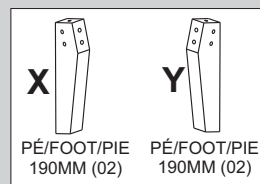

FIXAR PINO DE MINIFIX, TAMBOR E TAMPA / FIXING THE MINIFIX PIN, DRUM AND MINIFIX COVER
COLOQUE EL PINO E TAMBOR MINIFIX Y LA TAMPA

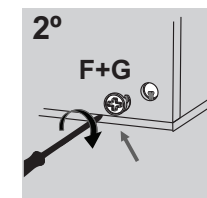
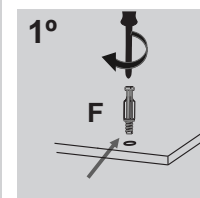

ITEM		DESCRIÇÃO DA PEÇAS / DESCRIPTION OF PARTS / UNIT MEASURE USED IS MILLIMETERS (MM)	CORES COLOR COLORES				
CÓDIGO CODE	Nº	NOME/NAME/NOMBRE	MEDIDAS / MEASURES (MM)	TIPO TYPE	QUANT AMOUNT CANTIDAD	BCO WHITE BLANCO	PRETO BLACK NEGRO
15795	1	PRATELEIRA / SHELF/ESTANTE	391X366X15	MDP	01	1/05	1/07
15794	2	LATERAL ESQUERDA/ LEFT SIDE/ LADO IZQUIERDO	450X383X15	MDP	01	2/05	2/07
15796	3	LATERAL DIREITA/ RIGHT SIDE/ LADO DERECHO	450X383X15	MDP	01	3/05	3/07
15797	4	TAMPO / TOP	425X385X15	MDP	01	4/05	4/07
15793	5	BASE	425X385X15	MDP	01	5/05	5/07
15801	6	FUNDO TRAS / BACK / TRASEIRO	410X296X3	TRI	01	6/05	6/07
15800	7	FUNDO TRAS / BACK / TRASEIRO	410X173X3	TRI	01	7/05	7/07
15792	8	FRENTE GAV./ DRAWER FRONT/ FRENTE DEL CAJÓN	387X120X15	MDP	01	8/21	8/07
15798	9	LAT.GAV.ESQ.DIR/LEFT/RIGHT DRAW. SIDE/LAD. CAJ.IZQ.DER.	350X86X15	MDP	02	9/05	9/07
15799	10	CONT. FRENT. GAV./FRONT AGAINST DRAWER	336X86X15	MDP	01	10/05	10/07
15802	11	FUNDO GAV. / DRAWER BACKGROUND/ FONDO CÁJON	358X366X3	TRI	01	11/05	11/07
15704	A	PF/ Screw/ Tornillo 5,0x50 CH			06		
438	B	PF. / Screw / Tornillo 4,0x40(MM) CH			08		
8233	C	PF/ Screw/ Tornillo 3,5x25 FL			01		
986	D	PF. / Screw/ Tornillo 3,5x14(MM) CRR			36		
137	E	Cavilha / Wooden Dowel / Tarugo 8x30(MM)			36		
532	F	Pino Minifix / Minifix Screw 32(MM)			04		
508	G	Tambor Minifix / Minifix Round Nut 15(MM)			04		
7687	H	Tapa Furo / Cover Cap 8(MM)			04	BCO	
952							PTO
15175	I	Cantoneira PL/Plast. corner with lid / Esquina PL. 20X20X42(MM)			02	CZA	CZA
911	J	Garra/ Jont Metal Plate/ Embragues			04		
248	K	Prego / Nail / Clavo 8x8(MM)			26		
139	L	Corred./Metallic Slid 350(MM) (01 Pair)			01		
13687	M	Puxador madeira/Wool handle/ Manija Madera			01	MOG	MOG
12734	N	Tapa F. Ades./ Holer Sticker/ Pegatina de Agugero 18 mm			06	BCO	
13363							PTO
15706	O	Cantoneira Metal/ Metal corner/ Esquina del metal 50X30X2 MM			04		
15574	W	Vista p/Pé Pinus Lateral/ Side Foot View/ Vista Lado del pie- 22X50X298MM			02	MOG	MOG
15577	X	Pé Pinus CHASSI-Lado X / Chassis foot-side X / Pie del chasis- lado X-190MM			02	MOG	MOG
15578	Y	Pé Pinus CHASSI-Lado Y / Chassis foot-side Y / Pie del chasis-lado Y- 190MM			02	MOG	MOG
15573	Z	Vista p/Pé Pinus Frontal/ Front Foot View/ Vista Front del pie-22X50X243MM			02	MOG	MOG
		Certif. de Garant./ Warranty Certif.			01		

PREPARAÇÃO DE PEÇAS/ PARTS PREPARATION / PREPARACION DE PIEZAS

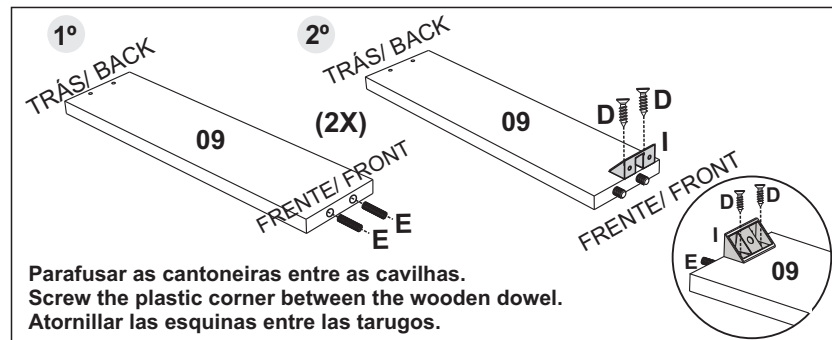
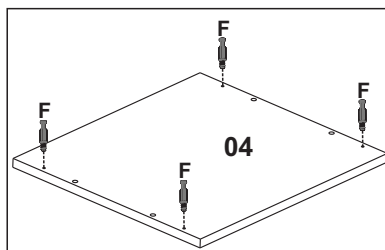
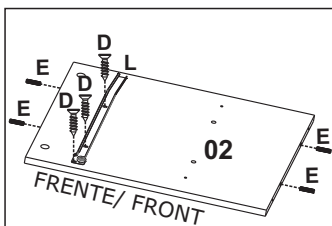
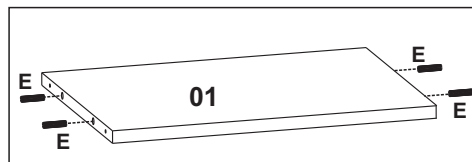
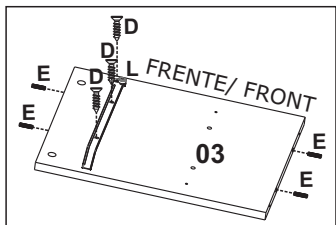

1 Obs: As peças pintadas nos passos são apenas ilustrativas.
The parts painted in the steps are illustrative only.
Las partes pintadas en los pasos son solo ilustrativas.

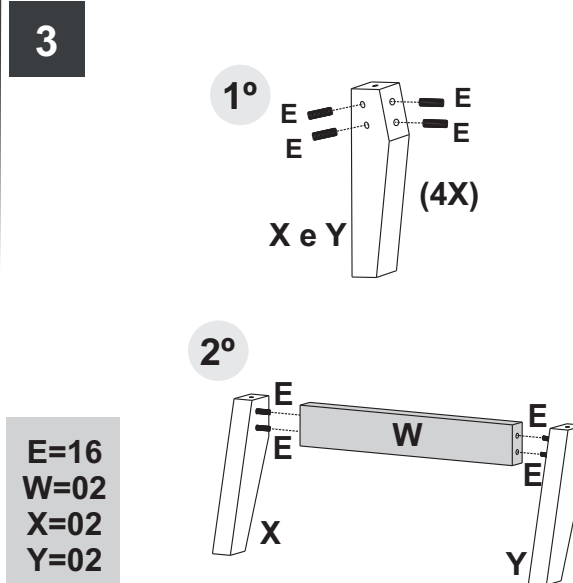
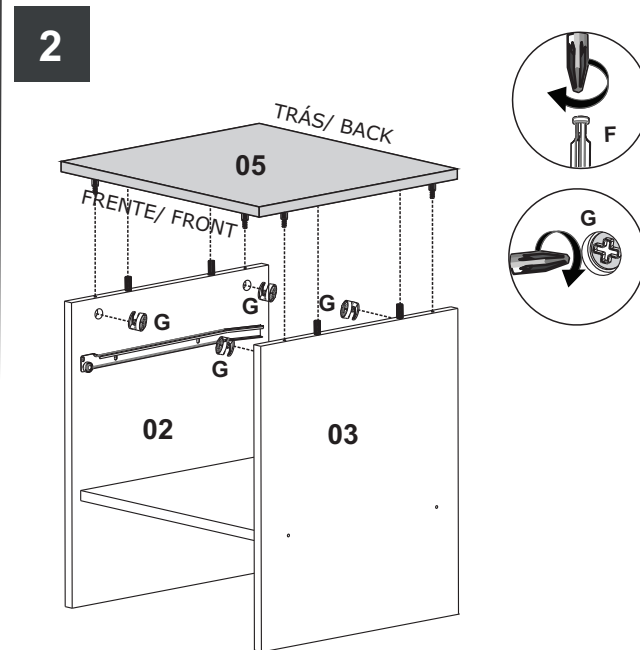
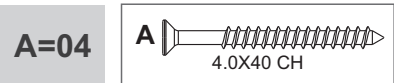
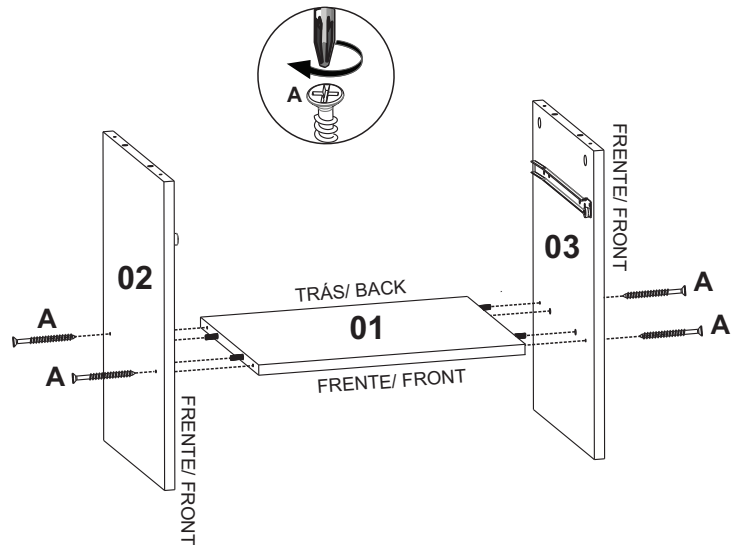

E=16
W=02
X=02
Y=02

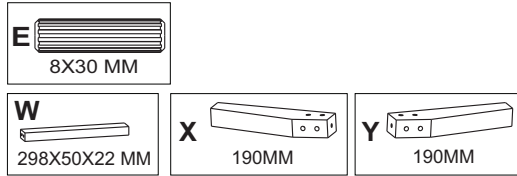

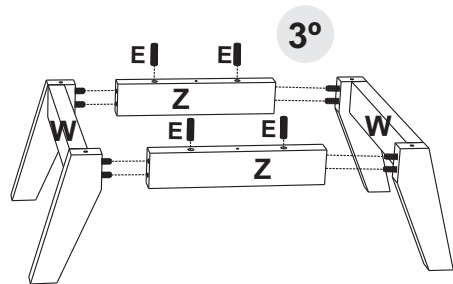

ATENÇÃO/
ATTENTION / ATENCION

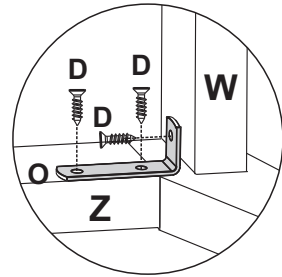

4

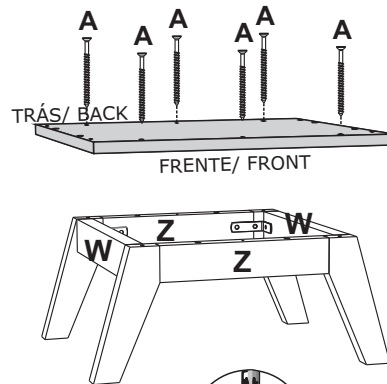

A=06

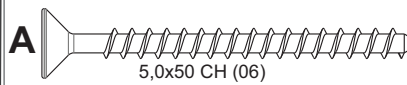

5

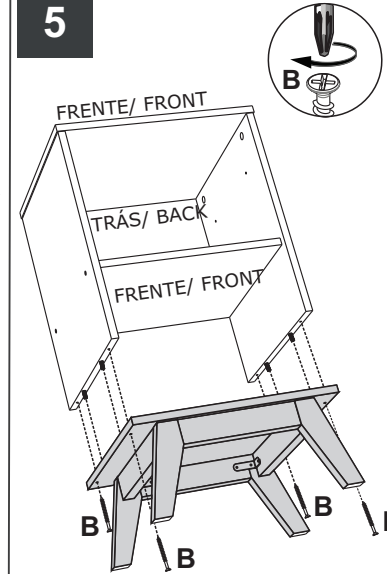

B=04

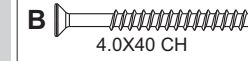

6

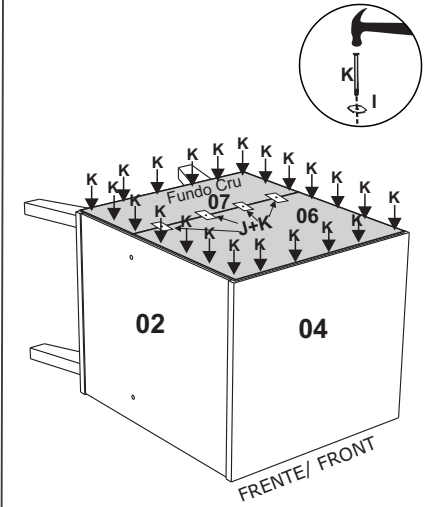

J=04
K=26

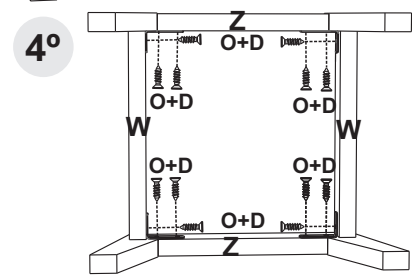

D=12
E=04
O=04
Z=02

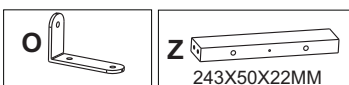

7

MONTAGEM GAVETA / ASSEMBLY OF THE DRAWER / MONTAJE LE CÁJON

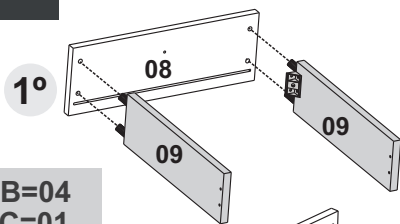

B=04
C=01
D=14
H=04
I=02
L1=02
M=01
N=06

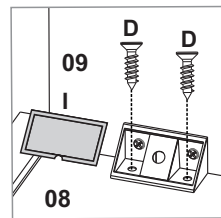

2°

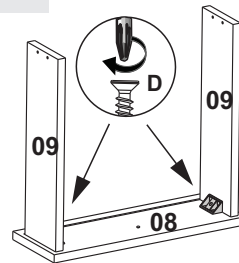

3°

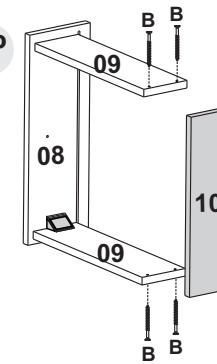

4°

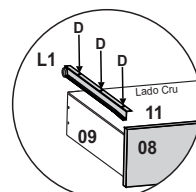
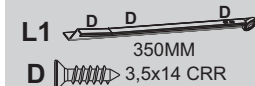
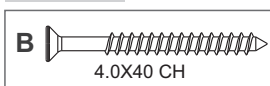
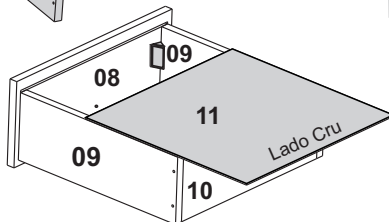

5°

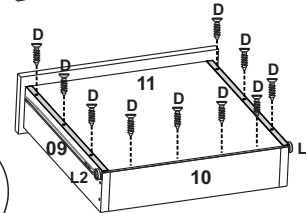

6°

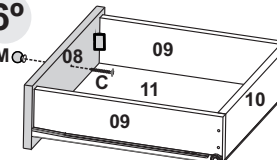
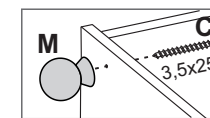

NOTA / NOTE

Não nos responsabilizamos por acidentes, se a instalação do móvel não estiver com os procedimentos deste Manual e não for realizado por pessoa habilitada. We are not responsible for accidents if the installation of the furniture is not in accordance with the procedures in this Manual and is not carried out by a qualified person. No nos hacemos responsables de accidentes si la instalación de los muebles no se realiza de acuerdo con los procedimientos de este Manual y no es realizada por una persona calificada.

