

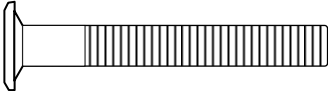
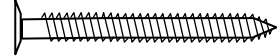
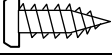
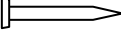
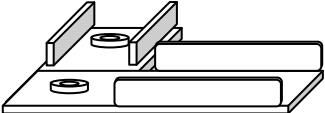
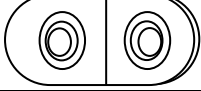

INSTRUÇÃO DE MONTAGEM - MESA LISBOA

(02 - Vol)

Pág 1

RELAÇÃO DE FERRAGENS (ESCALA 1 X 1)

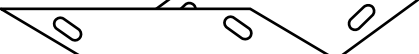
| CÓD | DESENHO | QTD | NOME (ONDE USAR) |
|-----|--|-----|--------------------|
| A |  | 16 | Parafuso 1/4" x 40 |
| B |  | 8 | Parafuso 4.0 x 40 |
| C |  | 36 | Parafuso 3.0 x 10 |
| D |  | 12 | Prego 8 x 8 |
| E |  | 4 | Sapata "L" 40 x 40 |
| F |  | 10 | Cantoneira 2 Furos |
| G |  | 16 | Porca Meia lua |
| H |  | 32 | Arruela Lisa 1/4" |
| I |  | 16 | Cantoneira 4 Furos |

DESCRIÇÃO DE PEÇAS

| QTD | NOME | DETALHES |
|-----|-----------------|------------------------|
| 1 | Tampo | MDP 800 x 1200 x 24 mm |
| 4 | Pé Furo Topo | MDP 750 x 85 x 12 mm |
| 4 | Pé Furo Lateral | MDP 750 x 100 x 12 mm |
| 2 | Travessa Menor | MDP 600 x 100 x 12 mm |
| 2 | Travessa Maior | MDP 905 x 100 x 12 mm |

DIMENSÕES DO PRODUTO MONTADO: 775 X 1095 X 750 MM

ATENÇÃO

- 1-Ler e observar atentamente toda instrução antes de iniciar a montagem.
- 2-A montagem do produto deverá ser feita em superfície limpa e plana. Aconselhamos utilizar a embalagem para forrar o chão a fim de não danificar o produto.
- 3-Os parafusos devem ser apertados periodicamente.
- 4-Evitar batidas e contatos com objetos cortantes.

LIMPEZA

- 1-Pano levemente umedecido com água, seguido de pano seco.
- 2-Não utilizar produtos químicos ou abrasivos.

PESO MÁXIMO SUPORTADO:
40 KG

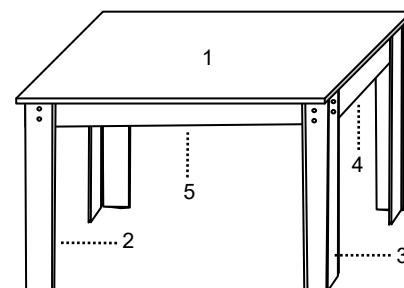



Ferramentas Necessárias (Não Fornecidas)



1 PESSOA

MONTANDO PASSO A PASSO

PARAF. 3,5 x 40
CÓD: B
QTD: 8

PREGO 8 x 8
CÓD: D
QTD: 12

SAPATA "L"
CÓD: E
QTD: 4

MONTAR 2 PÉS COM AS FURAÇÕES PARA O LADO ESQUERDO

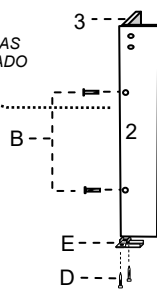

MONTAR 2 PÉS COM AS FURAÇÕES PARA O LADO DIREITO



1º PASSO: MONTAR OS PÉS DA MESA UTILIZANDO OS PARAFUSOS 4,8 X 50 E FIXAR AS SAPATAS "L" COM OS PREGOS 8 X 8

PARAF. 3,5x10
CÓD: C
QTD: 16

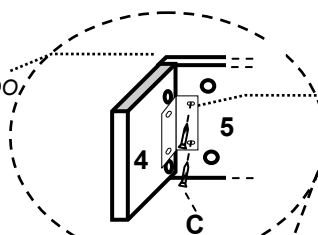

CANTONEIRA "L" 4 FUROS
CÓD: J
QTD: 4

TRAVESSAS MAIORES DO LADO DE FORA DAS TRAVESSAS MENORES

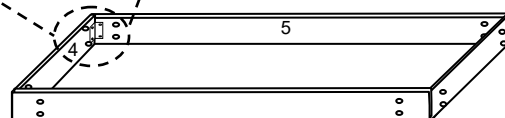

CENTRALIZAR A CANTONEIRA PARA NÃO TAPAR OS FUROS DAS TRAVESSAS

2º PASSO: PARAFUSAR A CANTONEIRA "L" 4 FUROS NA TRAVESSA Nº 4, AS TRAVESSAS MAIORES DO LADO DE FORA DAS TRAVESSAS MENORES FORMANDO UM QUADRO COM AS CANTONEIRAS "L" 4 FUROS



3º PASSO: PARAFUSAR OS PÉS NO QUADRO DE TRAVESSAS, FORMANDO A BASE DA MESA

PARAF. ¼" x 40
CÓD: A
QTD: 16

PORCA ¼"
CÓD: G
QTD: 16

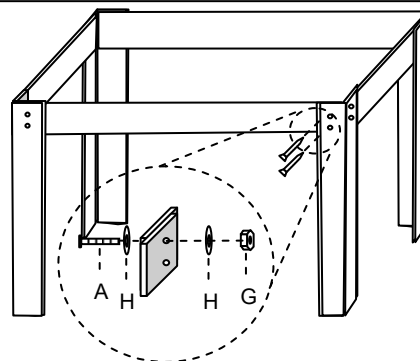

ARRUELA ¼"
CÓD: H
QTD: 32

ATENÇÃO: ALINHAR AS TRAVESSAS EM 90º ENCOSTANDO A PEÇA Nº 4 NA PEÇA Nº 2 E MANTÊ-LAS BEM ENCOSTADAS AO PARAFUSAR A CANTONEIRA



4º PASSO: PARAFUSAR A BASE DA MESA NO TAMPO (CONFORME MARCAÇÃO) USANDO AS CHAPINHAS "L"

DICA: PARA CENTRALIZAÇÃO DO TAMPO UTILIZE AS MARCAÇÕES ABAIXO.



PARAF. 3,5x 10
CÓD: C
QTD: 20

CHAPINHA "L"
CÓD: F
QTD: 10

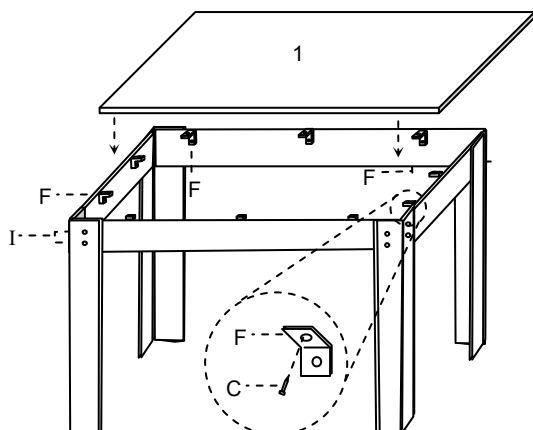
TAMPINHA
CÓD: I
QTD: 16

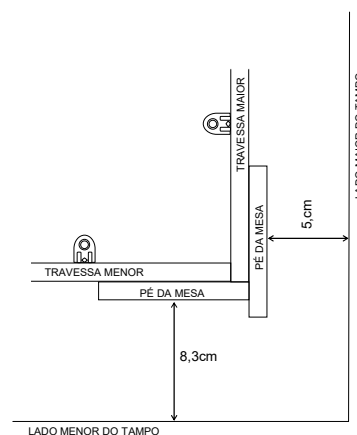

SEGUIR MARCAÇÃO DO TAMPO PARA CENTRALIZAR E PARAFUSAR A BASE DA MESA



IMPORTANTE: PARA FACILITAR A MONTAGEM, VIRE A MESA DE CABEÇA PARA BAIXO, PROTEGENDO AS PEÇAS PARA NÃO RISCAR