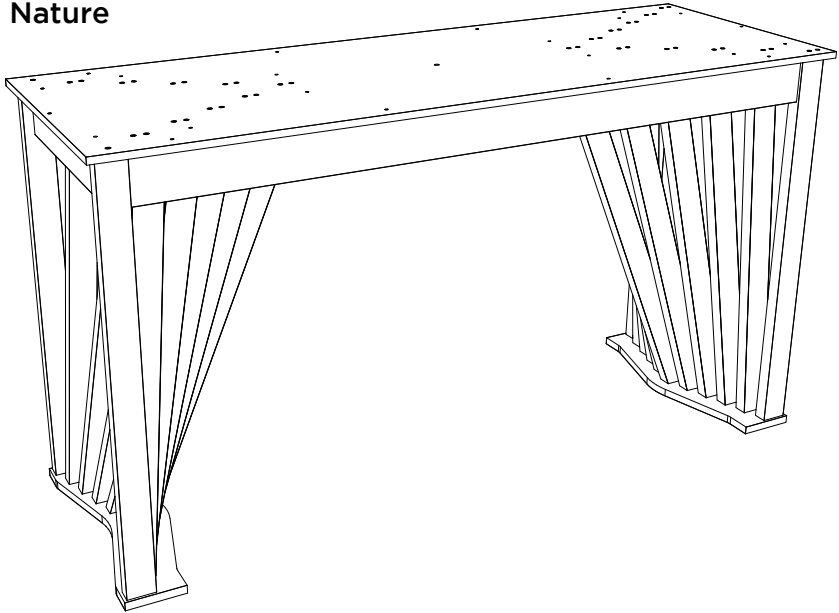
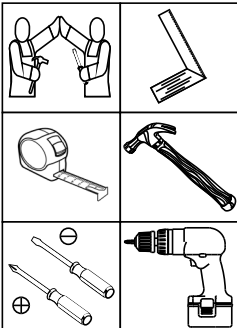

HENNInd. e Com. de Móveis Henn
Mondai - SC - Brasil

☎ +55 49 3674.3500

📱 @moveishenn
www.henn.com.br**INSTRUÇÕES DE
MONTAGEM**INSTRUCCIONES DE MONTAJE
ASSEMBLY INSTRUCTIONS**BASE ADRIANA | BASE ADRIANA | ADRIANA BASE****S420-128 Nature****Requisitos para montagem
Requisitos para la montaje
Assembly Requirements**

Imagens meramente ilustrativas,
não acompanha o produto.
Imágenes ilustrativas, no incluidas
con el producto.

Illustrative images, not included
with the product.

AVISO

Para limpeza de seu móvel, use uma flanela seca ou umedecida, e não utilize produtos químicos que possam danificar seu produto.

SISTEMA DE MONTAGEM

O sistema de montagem dos produtos, funciona de acordo com a ordem crescente dos números indicados no desenho. Ex.: 01, 02, 03, 04... até a conclusão da montagem.

ASSISTÊNCIA TÉCNICA

Para solicitação de Assistência Técnica você consumidor deverá entrar em contato com o Lojista o qual você realizou a compra deste produto e solicitar a assistência técnica das peças avariadas. A garantia abrange todas as peças, partes e componentes que eventualmente venham apresentar defeito de fabricação no prazo de 03 (três) meses, contando a partir da entrega do produto ao consumidor, mediante nota fiscal de compra. Se houver qualquer alteração na estrutura do produto ou ocorrer defeito por negligência do montador/consumidor em relação a instrução de montagem e manuseio, não será fornecido assistência técnica gratuita.

ADVERTENCIA

Para limpieza de su móvil, use una flanela seca o húmeda, y no utilice productos químicos que puedan dañar su producto.

SISTEMA DE MONTAJE

El sistema de montaje de los productos funciona de acuerdo con el orden creciente de los números indicados en el dibujo. Ej.: 01, 02, 03, 04... hasta la conclusión del montaje.

ASISTENCIA TÉCNICA

Para solicitar Asistencia Técnica, el consumidor debe comunicarse con el Comercio que usted realizó la compra de este producto y solicita asistencia técnica para las partes dañadas. La garantía cubre todas las partes, piezas y componentes que eventualmente puedan presentar defecto de fabricación en el plazo de 03 (tres) meses, contados a partir de la entrega del producto al consumidor, mediante factura de compra. Si se produce algún cambio en la estructura del producto o se produce un defecto por negligencia del montador/consumidor en relación con las instrucciones de montaje y manipulación, no se prestará asistencia técnica gratuita.

NOTICE

To clean your furniture, use a dry or wet cloth, and do not use chemicals that may damage your product.

ASSEMBLY SYSTEM

The products' assembly system works according to the increasing order of the indicated numbers. For example: 01, 02, 03, 04 ... to the end of the assembly.

TECHNICAL ASSISTANCE

To request Technical Assistance, the consumer must contact the retailer from whom you purchased this product and request technical assistance for the damaged parts. The warranty covers all parts, parts and components that may eventually present a manufacturing defect within a period of 03 (three) months, counting from the delivery of the product to the consumer, by means of a purchase invoice. If there is any change in the structure of the product or defect occurs due to negligence of the assembler/consumer in relation to the assembly and handling instruction, free technical assistance will not be provided.

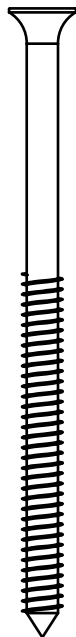

x4

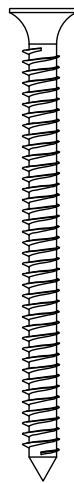

x16



x74



x10

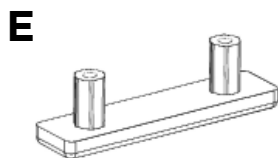

x6

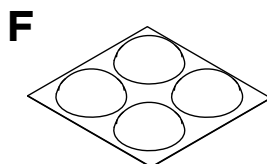

x8



x20

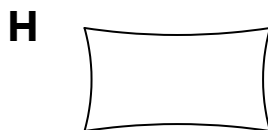

x1

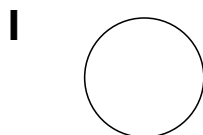

x12

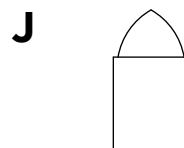

x1

Parafusos em escala
Tornillos escalados
Scaled screws **1:1**

LISTA DE PEÇAS | LISTA DE PIEZAS | LIST OF PIECES

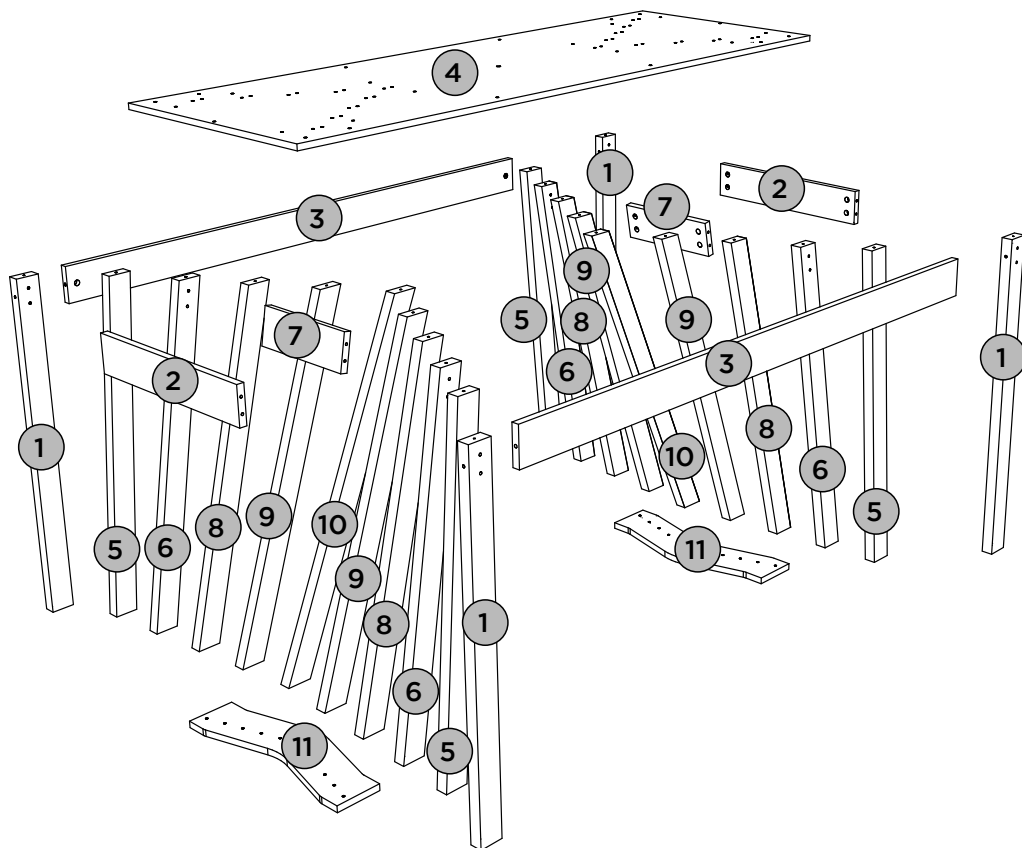

Item	Caixa Caja Box	Qty Ctd Qty	Descrição Descripción Description	Dimensões (mm) Dimensiones (mm)		
				Comprimento Largo Length	Largura Ancho Width	Espessura Grosor Thickness
1	1/1	04	PÉ PIE FOOT	739	50	25
2	1/1	02	TRAVESSA ESTRUTURAL MENOR TRAVESAÑO ESTRUCTURAL MENOR SMALLER STRUCTURAL TRAY	410	80	15
3	1/1	02	TRAVESSA ESTRUTURAL TRAVESAÑO ESTRUCTURAL CROSSBAR STRUCTURAL	1270	80	15
4	1/1	01	TAMPO ESTRUTURAL PARTE SUPERIOR ESTRUCTURAL STRUCTURAL TOP	1400	490	12
5	1/1	04	PÉ 5 PIE 5 FOOT 5	745	50	25
6	1/1	04	PÉ 6 PIE 6 FOOT 6	757	50	25
7	1/1	02	TRAVESSA ESTRUTURAL CRU TRAVESAÑO ESTRUCTURAL CRUDO RAW STRUCTURAL PLATTER	236	80	15
8	1/1	04	PÉ 8 PIE 8 FOOT 8	774	50	25
9	1/1	04	PÉ 9 PIE 4 FOOT 9	796	50	25
10	1/1	02	PÉ 10 PIE 5 FOOT 10	824	50	25
11	1/1	02	BASE BASE BASE	470	150	15

PASSO 1

ITM/S420-

PEÇAS REQUERIDAS

2	TRAVESSA ESTRUTURAL MENOR	x2
3	TRAVESSA ESTRUTURAL	x2
7	TRAVESSA ESTRUTURAL CRU	x2

ACESSÓRIOS REQUERIDOS

G		20
---	--	----

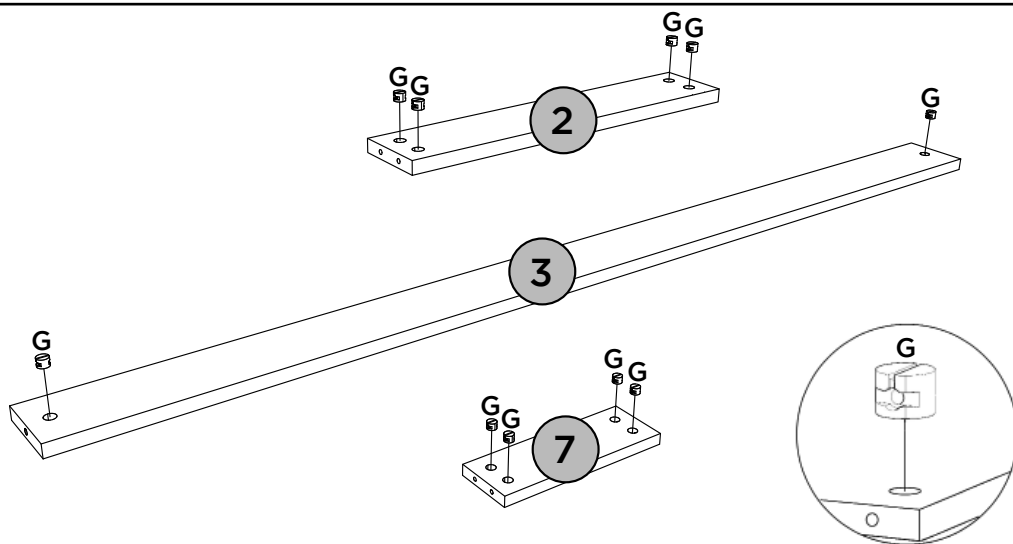

PASSO 2

PEÇAS REQUERIDAS

1	PÉ	x4
2	TRAVESSA ESTRUTURAL MENOR	x2

ACESSÓRIOS REQUERIDOS

B		08
---	---	----

FERRAMENTAS NECESSÁRIAS

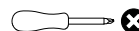
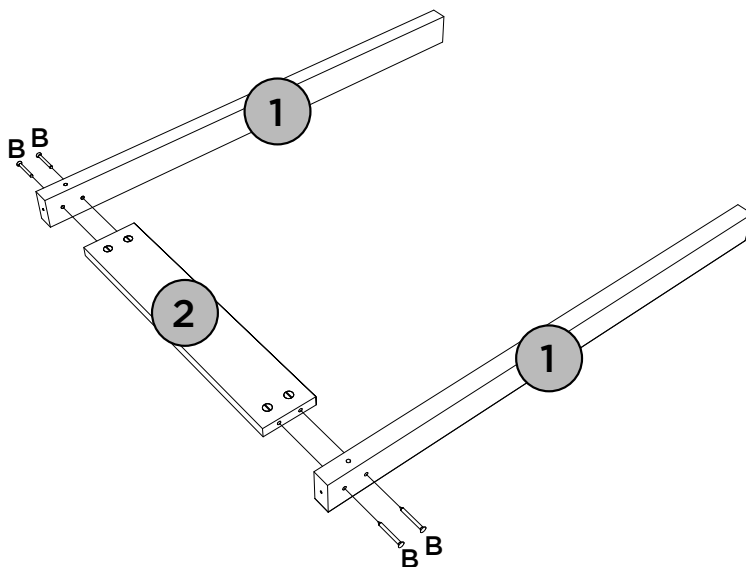
**2x**

PASSO 3

ITM/S420-

PEÇAS REQUERIDAS

3	TRAVESSA ESTRUTURAL	x2
---	---------------------	----

ACESSÓRIOS REQUERIDOS

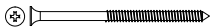
A		04
---	---	----

FERRAMENTAS NECESSÁRIAS

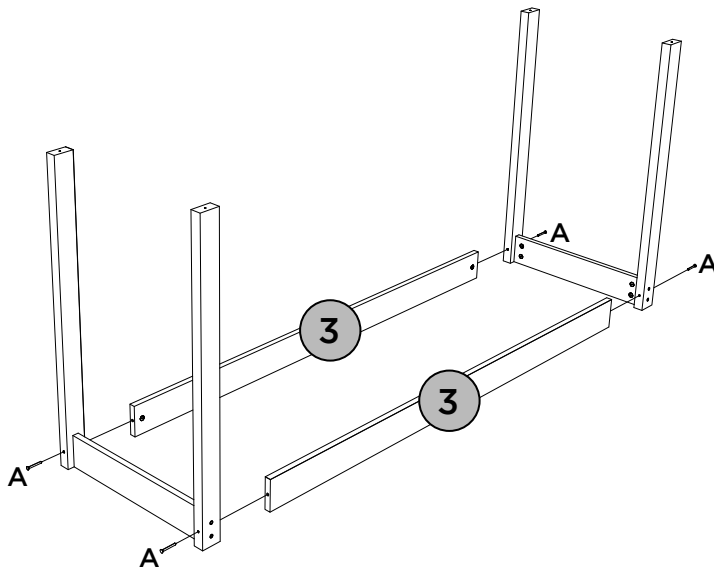
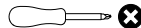

PASSO 4

PEÇAS REQUERIDAS

4	TAMPO ESTRUTURAL	x4
---	------------------	----

ACESSÓRIOS REQUERIDOS

C		16
---	---	----

FERRAMENTAS NECESSÁRIAS

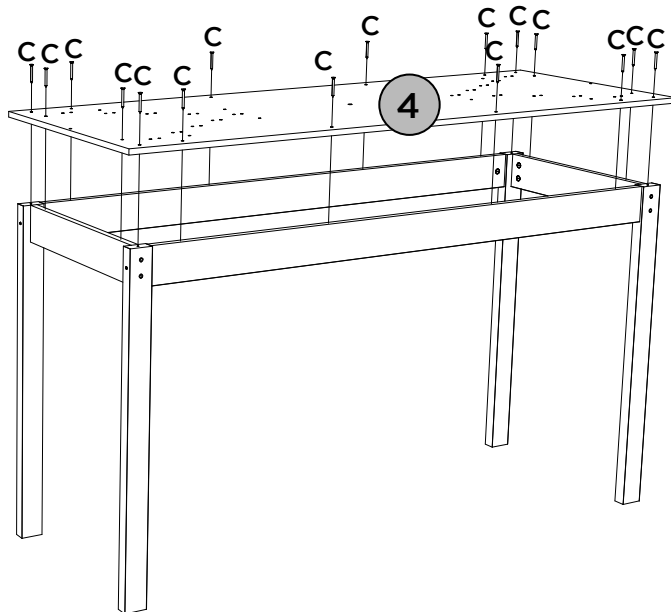
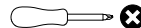



PASSO 5

ITM/S420-

PEÇAS REQUERIDAS

5	PÉ 5	x4
---	------	----

ACESSÓRIOS REQUERIDOS

C			O4
---	---	---	----

FERRAMENTAS NECESSÁRIAS

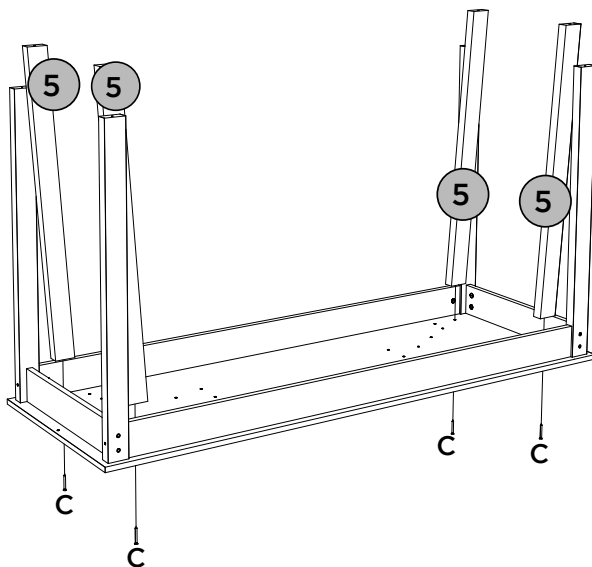
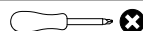

PASSO 6

PEÇAS REQUERIDAS

6	PÉ 6	
7	TRAVESSA ESTRUTURAL CRU	x2

ACESSÓRIOS REQUERIDOS

B			O8
---	---	---	----

FERRAMENTAS NECESSÁRIAS

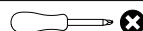

2x

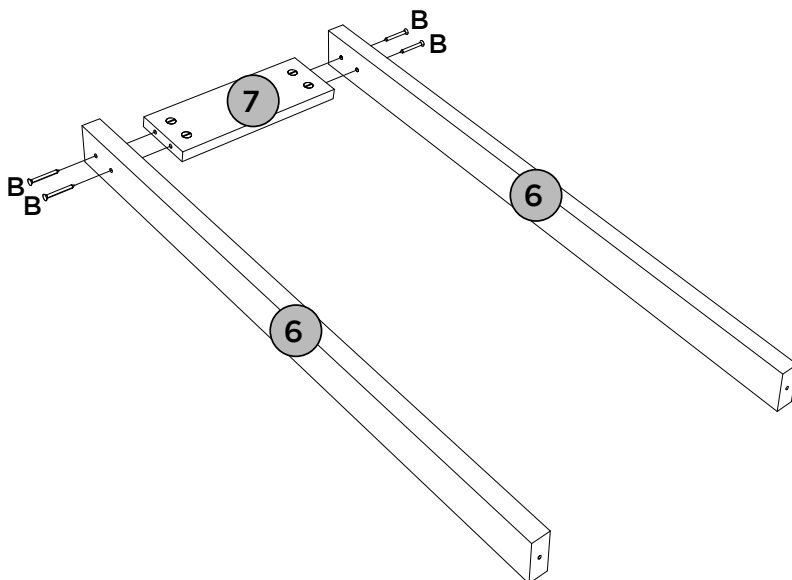

ACESSÓRIOS REQUERIDOS

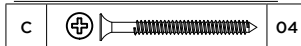

FERRAMENTAS NECESSÁRIAS

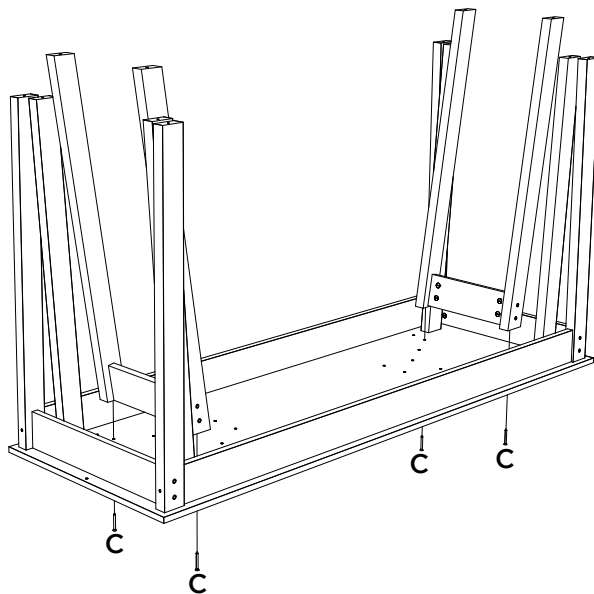
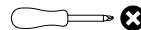

PASSO 8

PEÇAS REQUERIDAS

8	PÉ 8	x4
---	------	----

ACESSÓRIOS REQUERIDOS

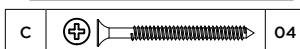

FERRAMENTAS NECESSÁRIAS

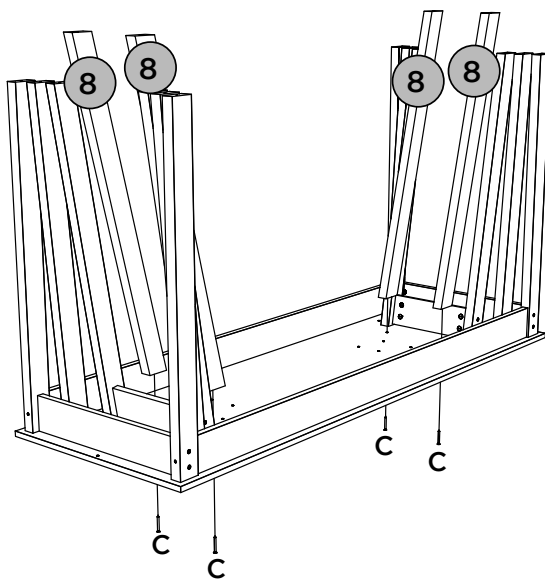
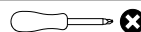



PASSO 9

ITM/S420-

PEÇAS REQUERIDAS

9	PÉ 9	x4
---	------	----

ACESSÓRIOS REQUERIDOS

C			04
---	---	---	----

FERRAMENTAS NECESSÁRIAS

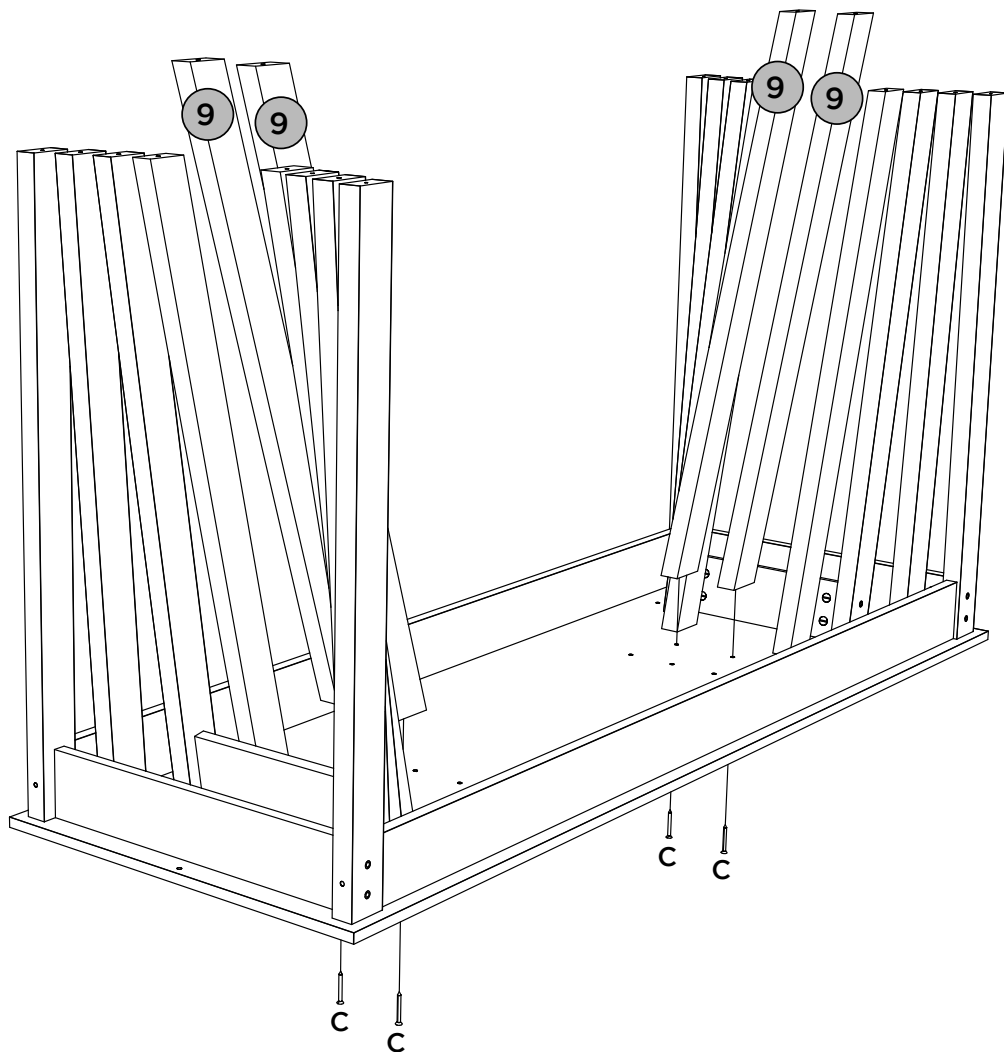

PASSO 10

ITM/S420-

PEÇAS REQUERIDAS

10	PÉ 10	x2
----	-------	----

ACESSÓRIOS REQUERIDOS

C		02
---	---	----

FERRAMENTAS NECESSÁRIAS

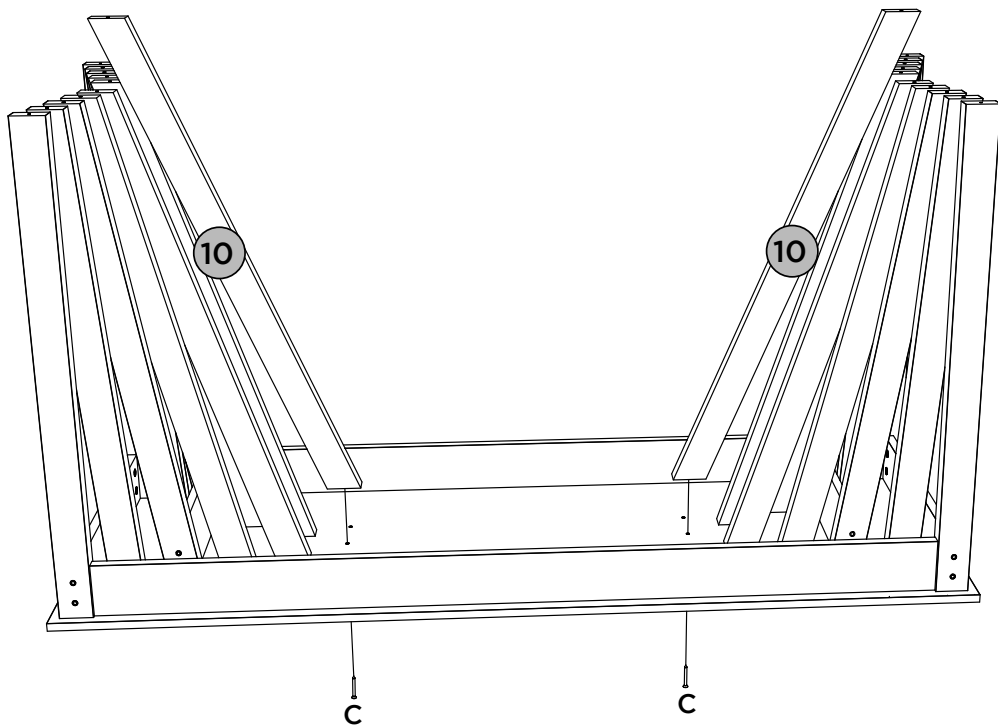
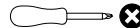

PASSO 11

ITM/S420-

PEÇAS REQUERIDAS

11	BASE	x2
----	------	----

ACESSÓRIOS REQUERIDOS

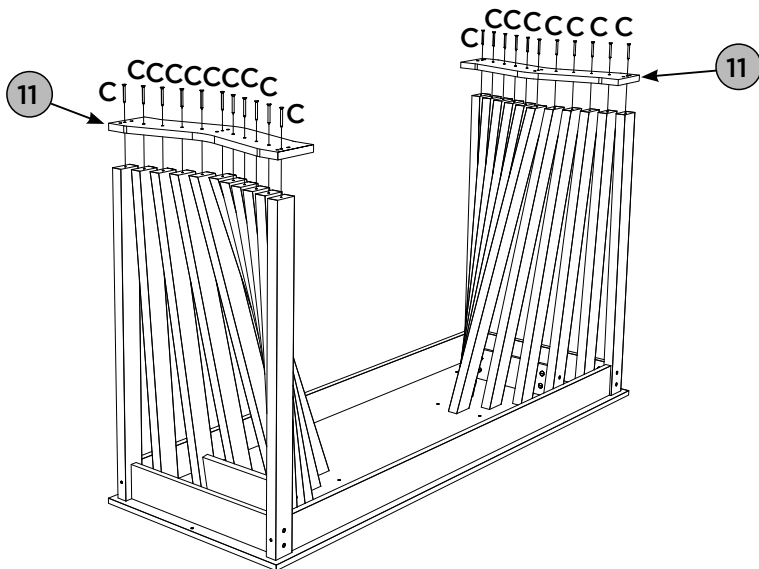
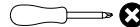

C		22
---	---	----

FERRAMENTAS NECESSÁRIAS



PASSO 12

ACESSÓRIOS REQUERIDOS

E		06
H		01

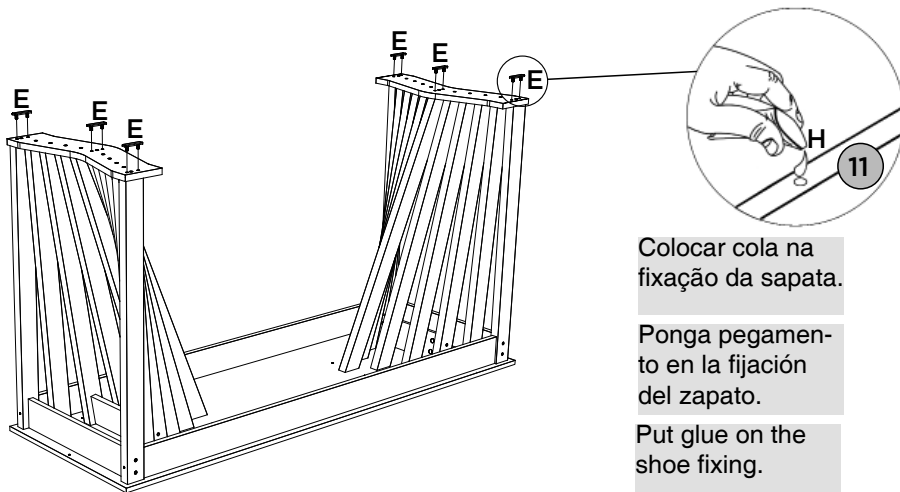

Colocar cola na fixação da sapata.

Ponga pegamento en la fijación del zapato.

Put glue on the shoe fixing.

ACESSÓRIOS REQUERIDOS

FERRAMENTAS NECESSÁRIAS

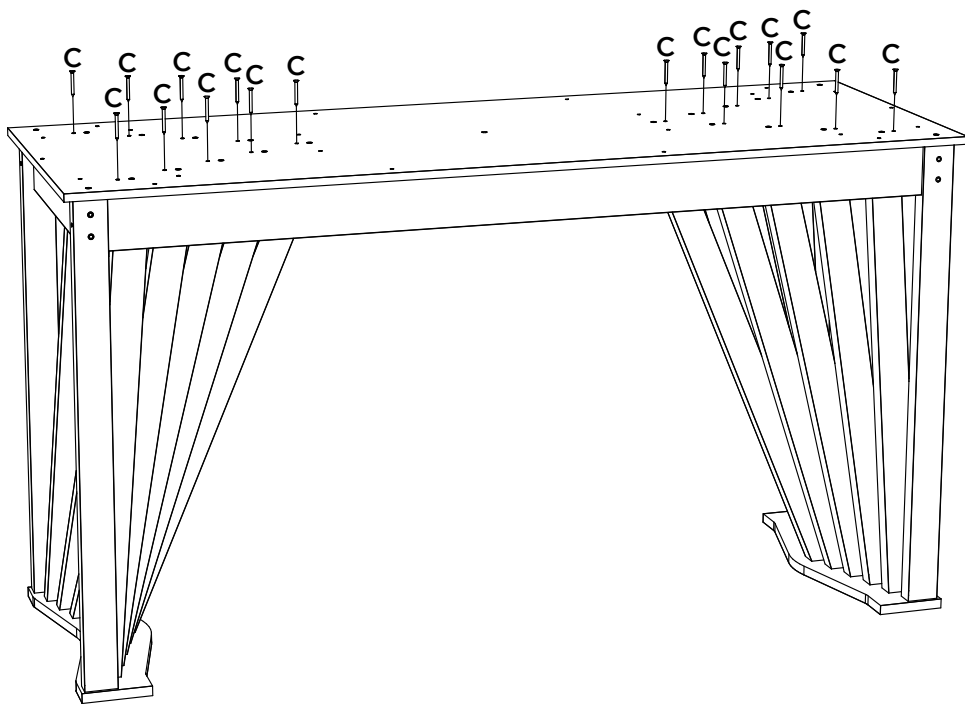
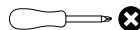
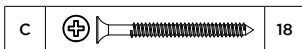

Opção de Montagem com o Tampo 2000x900
canto reto com Vidro (S906-139)

Opción de montaje con parte superior 2000x900
esquina recta con vidrio (S906-139)

Mounting Option with Top 2000x900
straight corner with Glass (S906-139)

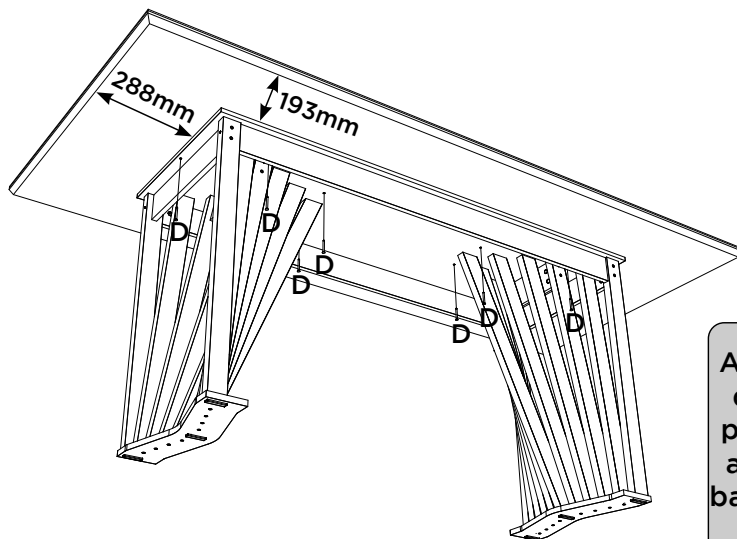

A pintura do Vidro
deve ficar virada
para baixo, depois
ajustá-lo sobre os
batentes de silicone
(F)

La pintura de
vidrio debe mirar
hacia abajo, luego
ajustarla sobre los
topes de silicona
(F)

The glass paint
should be facing
downwards, then
adjust it over the
silicone stops (F)

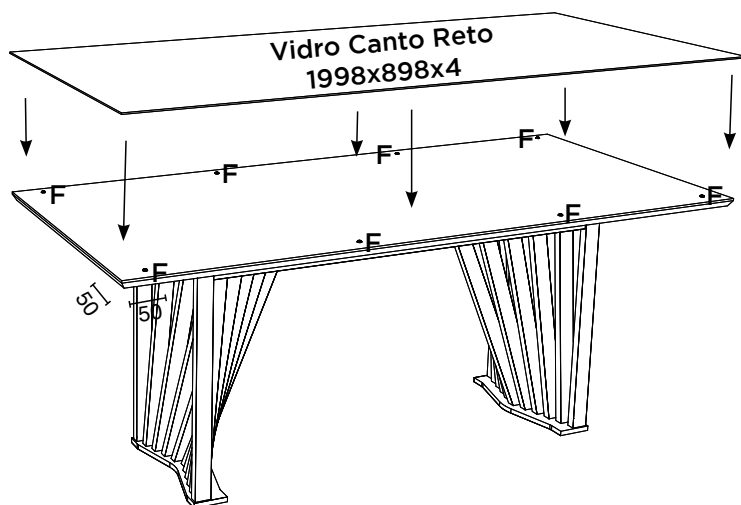

Produto Concluído (S420 + S906)
Producto Terminado (S420 + S906)
Finished Product (S420 + S906)

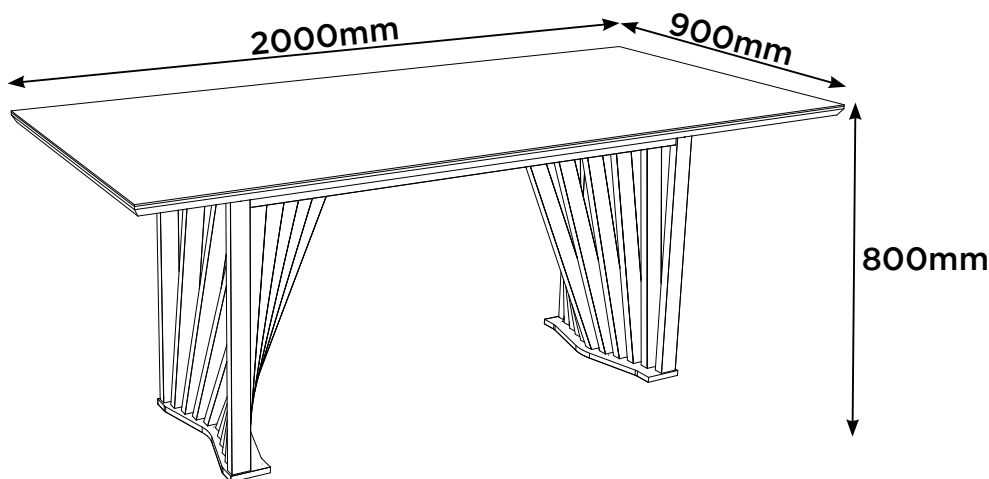

**Opção de Montagem com o Tampo 2000x900
 canto moeda com Vidro (S907-139)**

**Opción de montaje con parte superior 2000x900
 Esquina de monedas con vidrio (S907-139)**

**Mounting Option with Top 2000x900
 Coin corner with Glass (S907-139)**

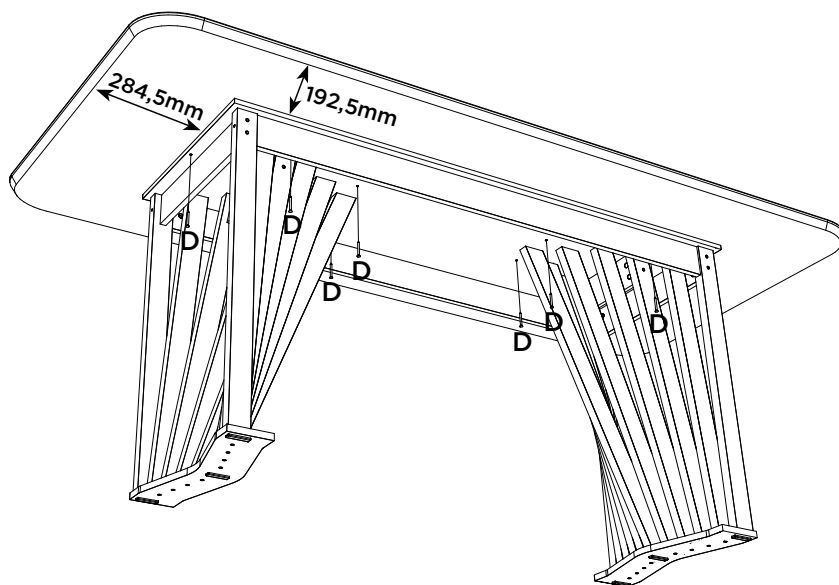

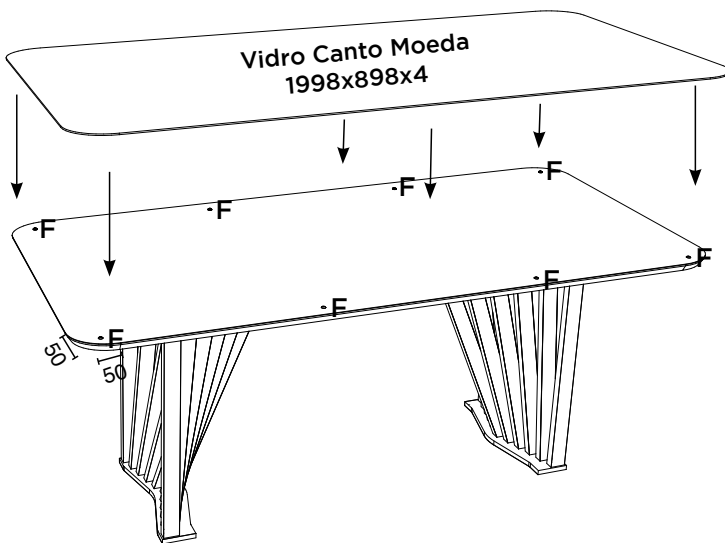

A pintura do Vidro deve ficar virada para baixo, depois ajustá-lo sobre os batentes de silicone (F)

La pintura de vidrio debe mirar hacia abajo, luego ajustarla sobre los topes de silicona (F)

The glass paint should be facing downwards, then adjust it over the silicone stops (F)

Produto Concluído (S420 + S907)
Producto Terminado (S420 + S907)
Finished Product (S420 + S907)

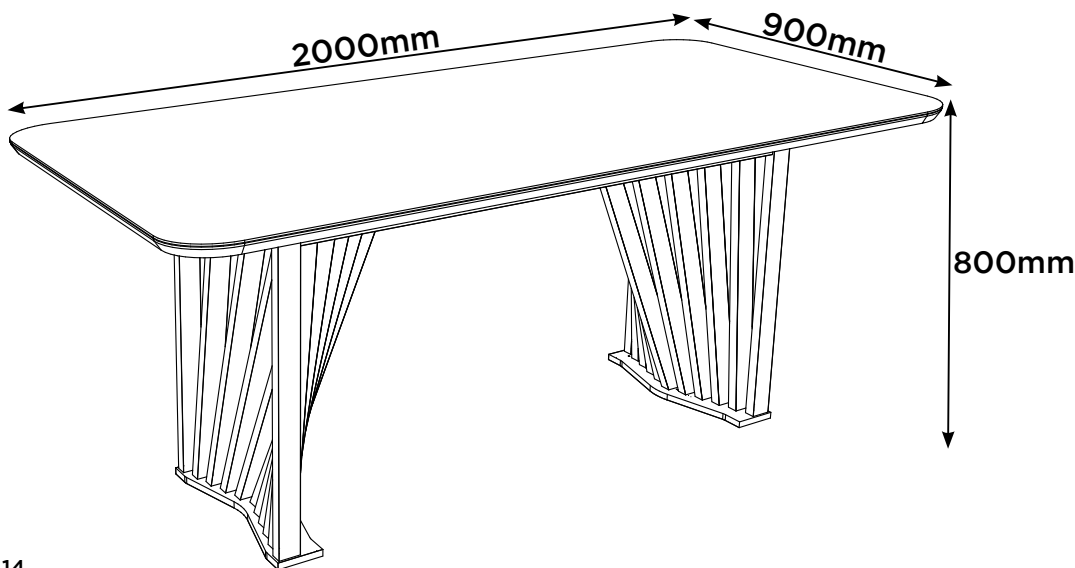

Opção de Montagem com o Tampo 1600x900
canto reto com Vidro (S908-139)

Opción de montaje con parte superior 1600x900
esquina recta con vidrio (S908-139)

Mounting Option with Top 1600x900
straight corner with Glass (S908-139)

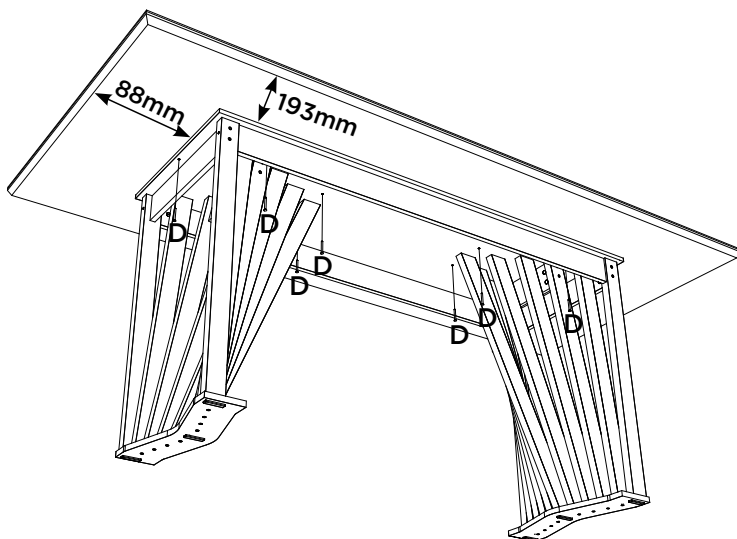

A pintura do Vidro
deve ficar virada
para baixo, depois
ajustá-lo sobre os
batentes de silicone
(F)

La pintura de
vidrio debe mirar
hacia abajo, luego
ajustarla sobre los
topes de silicona
(F)

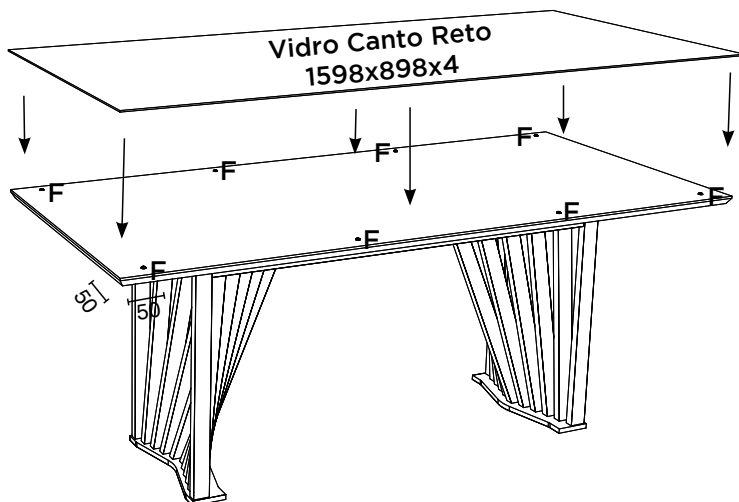

The glass paint
should be facing
downwards, then
adjust it over the
silicone stops (F)

Produto Concluído (S420 + S908)
Producto Terminado (S420 + S908)
Finished Product (S420 + S908)

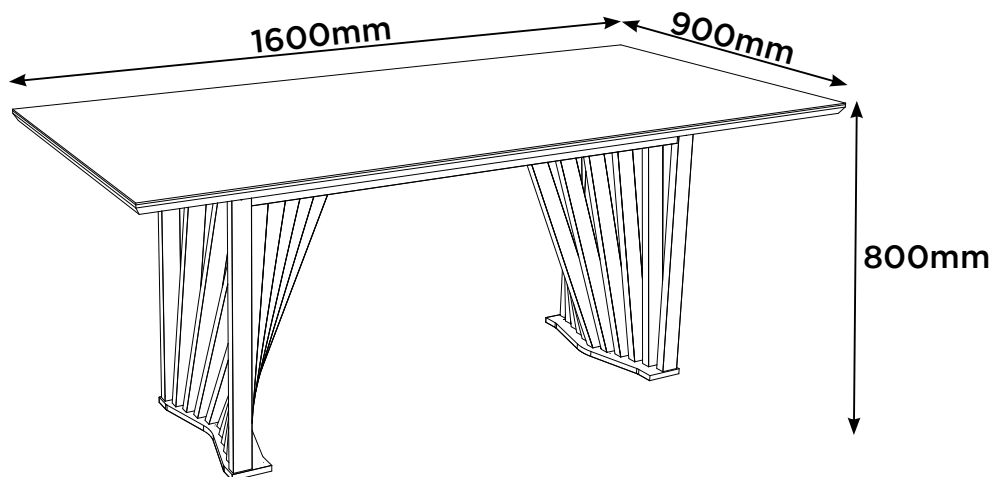

**Opção de Montagem com o Tampo 1600x900
 canto moeda com Vidro (S909-139)**

**Opción de montaje con parte superior 1600x900
 Esquina de monedas con vidrio (S909-139)**

**Mounting Option with Top 1600x900
 Coin corner with Glass (S909-139)**

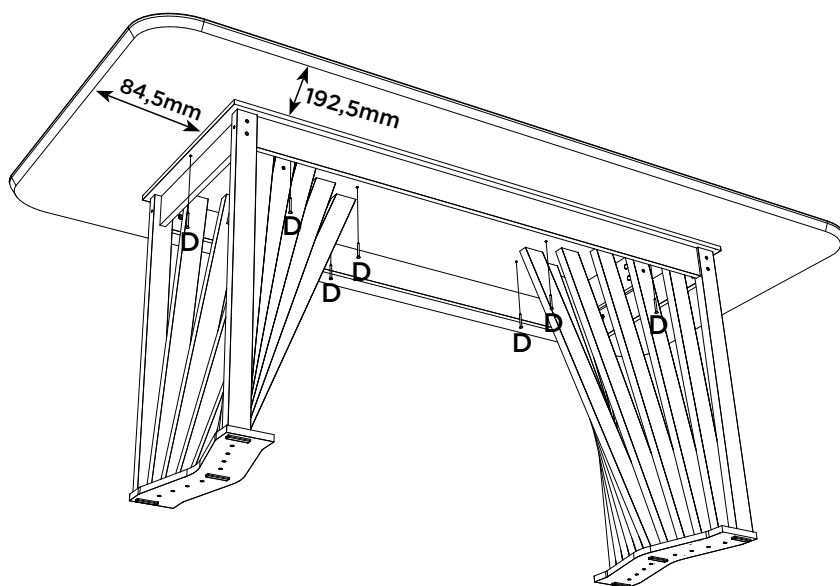

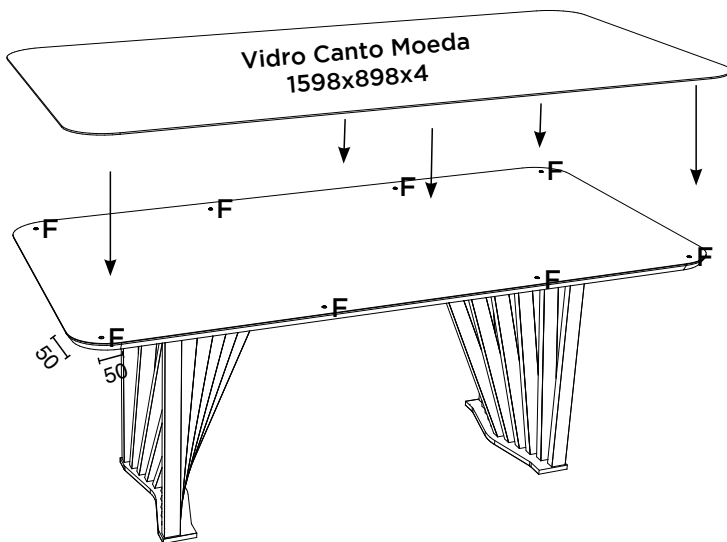

A pintura do Vidro deve ficar virada para baixo, depois ajustá-lo sobre os batentes de silicone (F)

La pintura de vidrio debe mirar hacia abajo, luego ajustarla sobre los topes de silicona (F)

The glass paint should be facing downwards, then adjust it over the silicone stops (F)

Produto Concluído (S420 + S909)
Producto Terminado (S420 + S909)
Finished Product (S420 + S909)

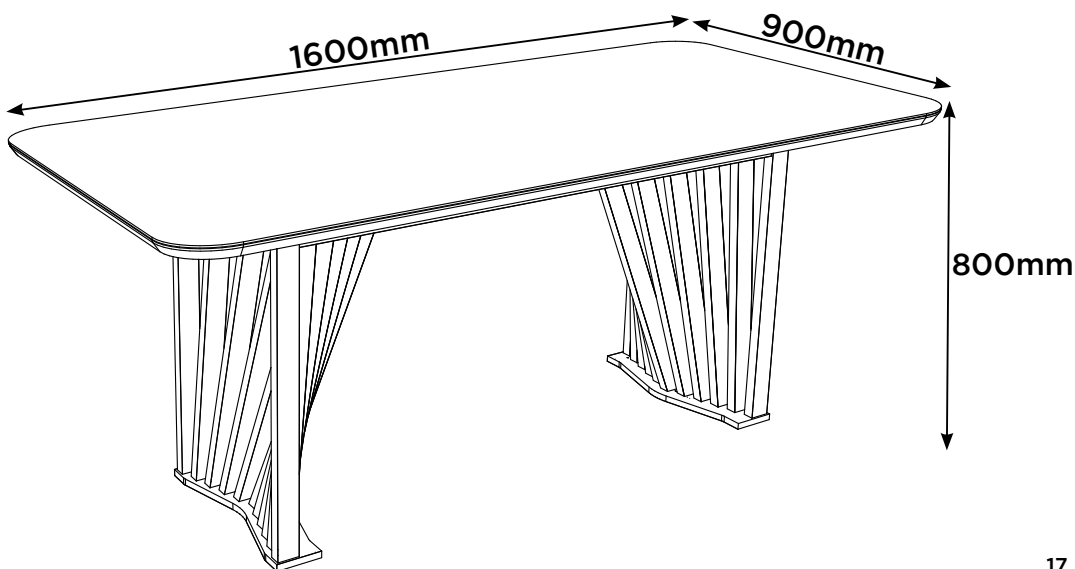

Opção de Montagem com o Tampo 1600x900
canto reto sem Vidro (S910-139)

Opción de montaje con parte superior 1600x900
esquina recta sin vidrio (S910-139)

Mounting Option with Top 1600x900
straight corner without Glass (S910-139)

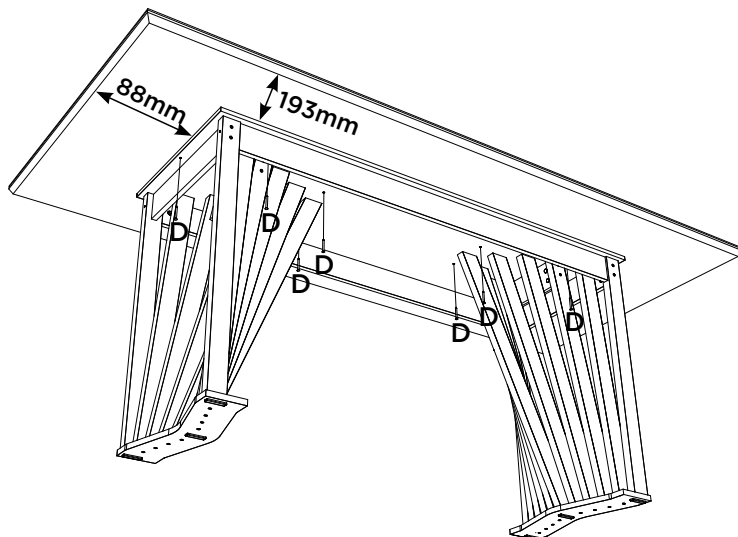

Produto Concluído (S420 + S910)
Producto Terminado (S420 + S910)
Finished Product (S420 + S910)

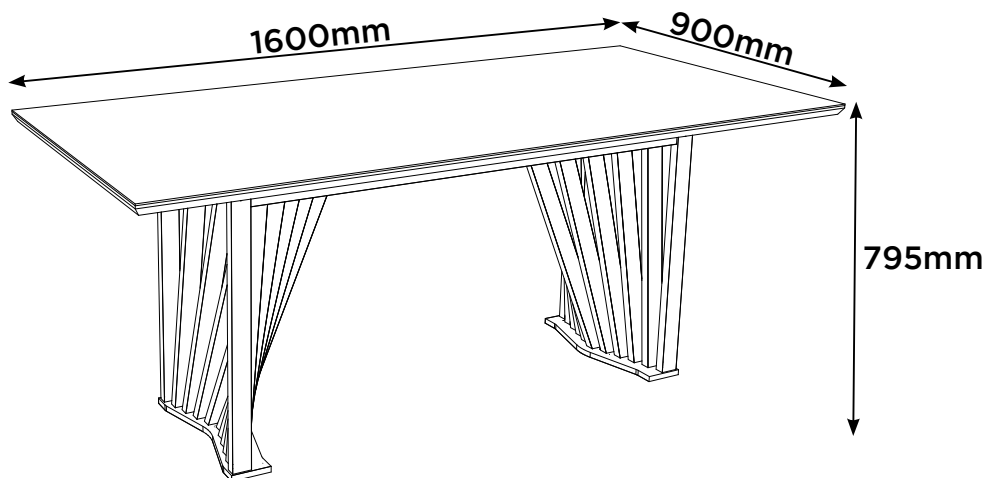

Pesos máximos recomendados con carga distribuída
Peso máximo recomendado con la carga distribuida
Recommended maximum weight with distributed load.

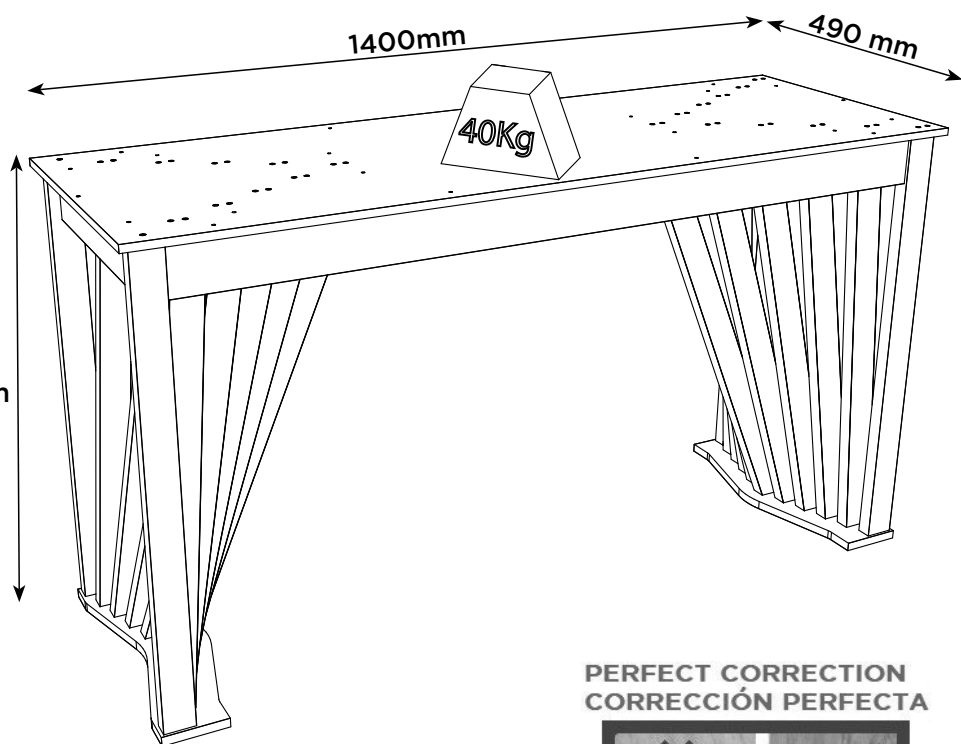

PERFECT CORRECTION
CORRECCIÓN PERFECTA

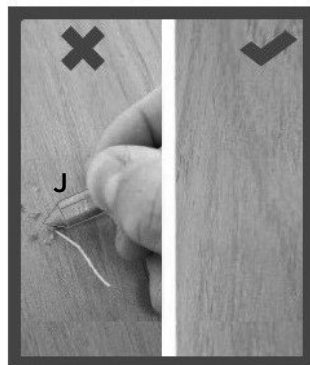
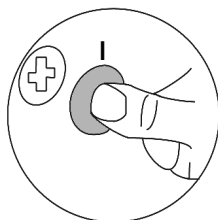

Produto Concluído
Producto terminado
Finished Product

