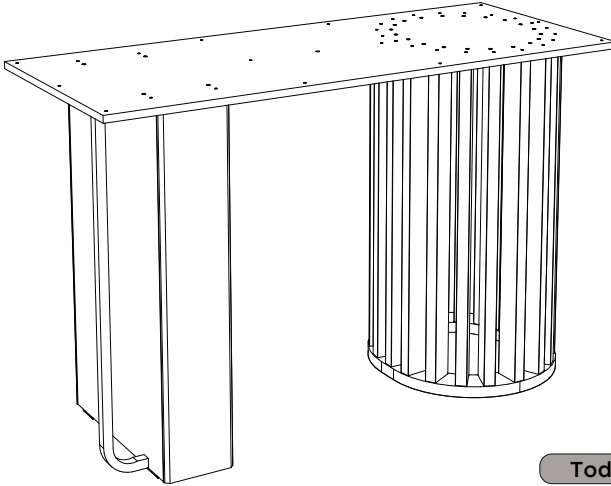

HENNInd. e Com. de Móveis Henn
Mondai - SC - Brasil

☎ +55 49 3674.3500

📷 📱 @moveishenn
www.henn.com.br**INSTRUÇÕES DE
MONTAGEM****INSTRUCCIONES DE MONTAJE
ASSEMBLY INSTRUCTIONS****BASE MESA FANY | BASE MESA FANY | FANY TABLE BASE****S436-129 Off White/Nature****Todas medidas em mm.****Todas las medidas en mm.****All measurements in mm.****AVISO**

Para limpeza de seu móvel, use uma flanela seca ou umedecida, e não utilize produtos químicos que possam danificar seu produto.

SISTEMA DE MONTAGEM

O sistema de montagem dos produtos, funciona de acordo com a ordem crescente dos números indicados no desenho. Ex: 01, 02, 03, 04... até a conclusão da montagem.

ASSISTÊNCIA TÉCNICA

Para solicitação de Assistência Técnica você consumidor deverá entrar em contato com o Lojista o qual você realizou a compra deste produto e solicitar a assistência técnica das peças avariadas. A garantia abrange todas as peças, partes e componentes que eventualmente venham apresentar defeito de fabricação no prazo de 03 (três) meses, contando a partir da entrega do produto ao consumidor, mediante nota fiscal de compra. Se houver qualquer alteração na estrutura do produto ou ocorrer defeito por negligência do montador/consumidor em relação a instrução de montagem e manuseio, não será fornecido assistência técnica gratuita.

ADVERTENCIA

Para limpieza de su móvil, use una flanela seca o húmeda, y no utilice productos químicos que puedan dañar su producto.

SISTEMA DE MONTAJE

El sistema de montaje de los productos funciona de acuerdo con el orden creciente de los números indicados en el dibujo. Ej.: 01, 02, 03, 04... hasta la conclusión del montaje.

ASISTENCIA TÉCNICA

Para solicitar Asistencia Técnica, el consumidor debe comunicarse con el Comercio que usted realizó la compra de este producto y solicita asistencia técnica para las partes dañadas. La garantía cubre todas las partes, piezas y componentes que eventualmente puedan presentar defecto de fabricación en el plazo de 03 (tres) meses, contados a partir de la entrega del producto al consumidor, mediante factura de compra. Si se produce algún cambio en la estructura del producto o se produce un defecto por negligencia del montador/consumidor en relación con las instrucciones de montaje y manipulación, no se prestará asistencia técnica gratuita.

NOTICE

To clean your furniture, use a dry or wet cloth, and do not use chemicals that may damage your product.

ASSEMBLY SYSTEM

The products' assembly system works according to the increasing order of the indicated numbers. For example: 01, 02, 03, 04 ... to the end of the assembly.

TECHNICAL ASSISTANCE

To request Technical Assistance, the consumer must contact the retailer from whom you purchased this product and request technical assistance for the damaged parts. The warranty covers all parts, parts and components that may eventually present a manufacturing defect within a period of 03 (three) months, counting from the delivery of the product to the consumer, by means of a purchase invoice. If there is any change in the structure of the product or defect occurs due to negligence of the assembler/consumer in relation to the assembly and handling instruction, free technical assistance will not be provided.

ACESSÓRIOS | ACCESORIOS | ACCESSORIES

A x24

Parafuso 3,5x40mm CHT.

B x16

Parafuso 4,0x25mm CHT.

C x1

Parafuso M4x20mm CHT.

D x49

Parafuso 3,5x12mm CHT.

E x44

Cavilha 5x25mm.

F x12

Cantoneira 17,5 x 17,5 x 44mm.

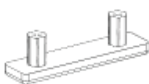
G x8

Sapata 4x50x12mm.

H x1

Metalon L Curvado 750x20x20.

I KIT x2

Kit Batente de Silicone.

J x2

Sache de Cola.

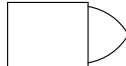
K x2

Giz de Correção.

L x20

Parafuso 4,5x50mm CHT.

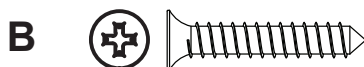
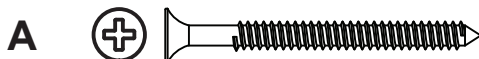

LISTA DE PEÇAS | LISTA DE PIEZAS | LIST OF PIECES

Item	Caixa Caja Box	Qtd Ctd Qty	Descrição Descripción Description	Dimensões (mm) Dimensiones (mm) Dimensions (mm)		
				Comprimento Largo Length	Largura Ancho Width	Espessura Grosor Thickness
1	1/1	02	LATERAL LADO SIDE	751	426	12
2	1/1	02	LATERAL MENOR LADO PEQUEÑO SMALLER SIDE	751	152	12
3	1/1	01	BASE BASE BASE	450	400	25
4	1/1	20	PILASTRA PILASTRA PILASTER	726	60	25
5	1/1	01	TAMPO ESTRUTURAL TAPA ESTRUTURAL STRUCTURAL TOP	1200	500	15

VISTA EXPLODIDA DAS PEÇAS | VISTA DESPIECE DE LAS PIEZAS | EXPLODED VIEW OF THE PARTS.

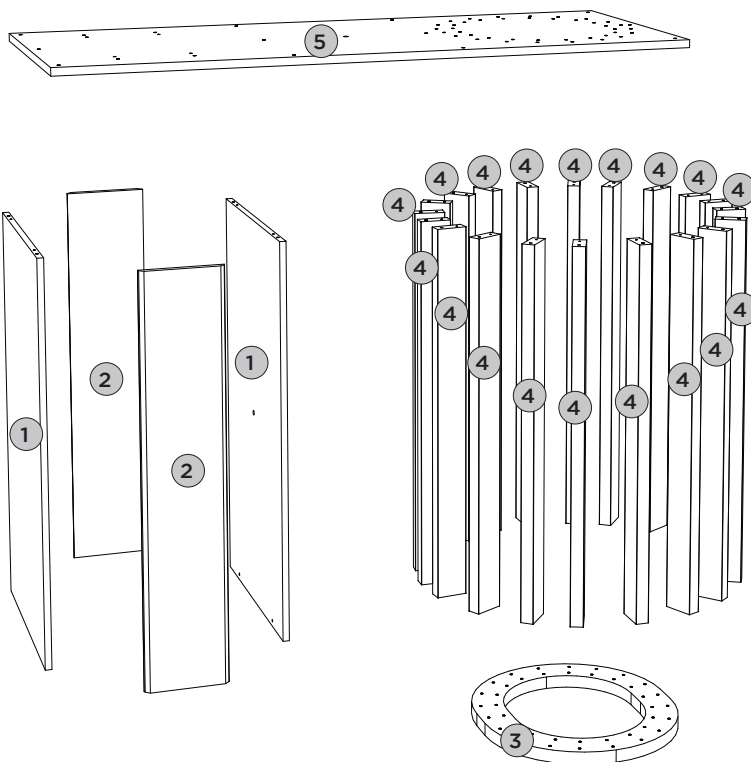

REQUISITOS PARA MONTAGEM REQUISITOS PARA LA MONTAJE | ASSEMBLY REQUIREMENTS.

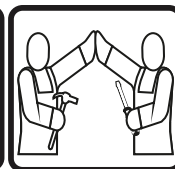
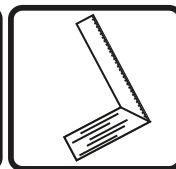
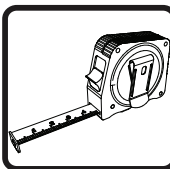
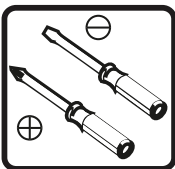
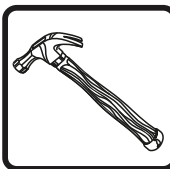
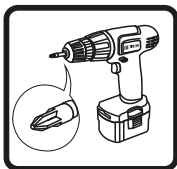

Imagens meramente ilustrativas, não acompanha o produto.
 Imágenes ilustrativas, no incluidas con el producto.
 Illustrative images, not included with the product.

PEÇAS REQUERIDAS

1	LATERAL	x2
3	BASE	x1
4	PILAISTRA	x20

ACESSÓRIOS REQUERIDOS

C		01
D		24
E		44
F		12
G		08

FERRAMENTAS NECESSÁRIAS

H			01
J			

Fazer furação passante para fixar o Metalon (H)

Taladrar agujeros para fijar el Metalon (H)

Drill holes to fix the Metalon (H)

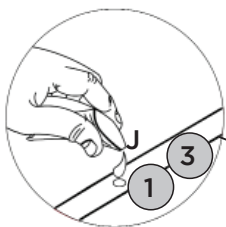
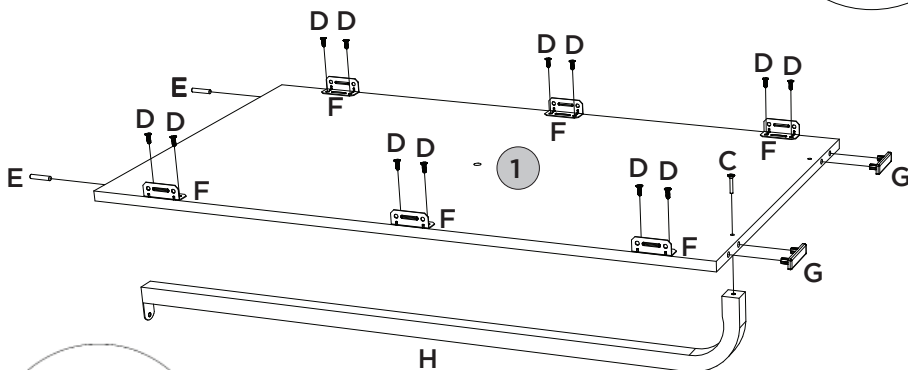
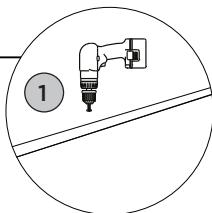

Colocar cola na fixação da sapata.

Ponga pegamento en la fijación del zapato.

Put glue on the shoe fixing.

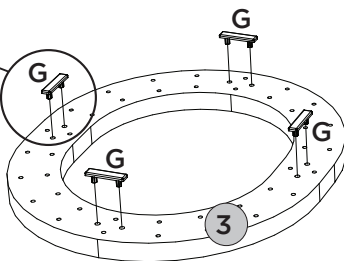

Utilizar o sachê de cola (J) em todas as cavilhas (E) do produto.

Con el pegamento sobre (J) en todos los pernos (E) producto.

Use the glue sachet (J) on all the pegs (E) of the product.

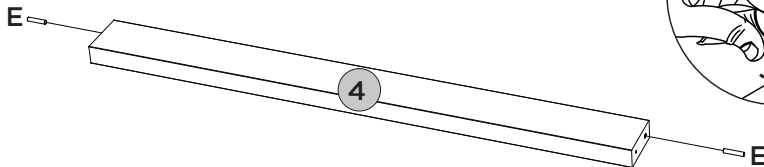

PEÇAS REQUERIDAS

1	LATERAL	x2
2	LATERAL MENOR	x2

ACESSÓRIOS REQUERIDOS

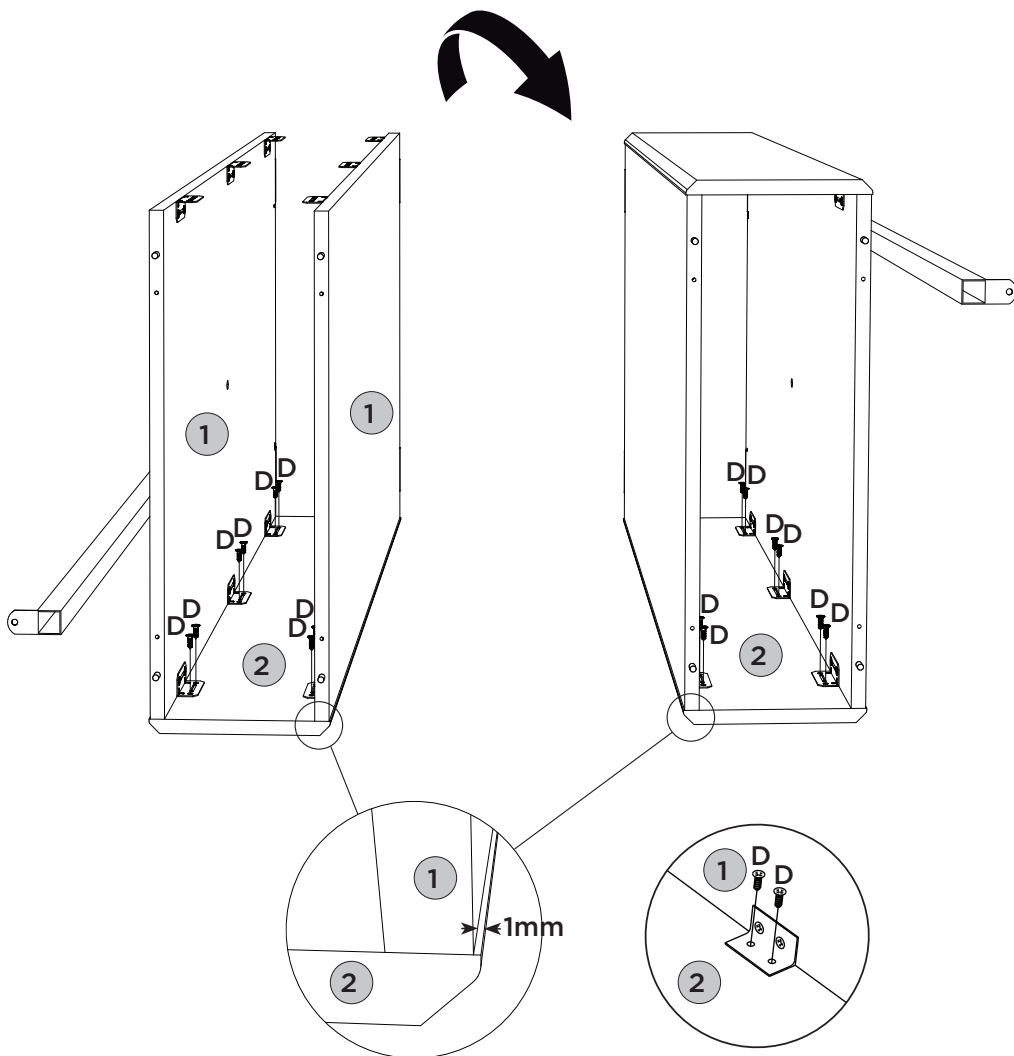
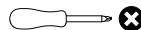

D		24
---	---	----

FERRAMENTAS NECESSÁRIAS

PEÇAS REQUERIDAS

3	BASE	x1
4	PILASTRA	x20

ACESSÓRIOS REQUERIDOS

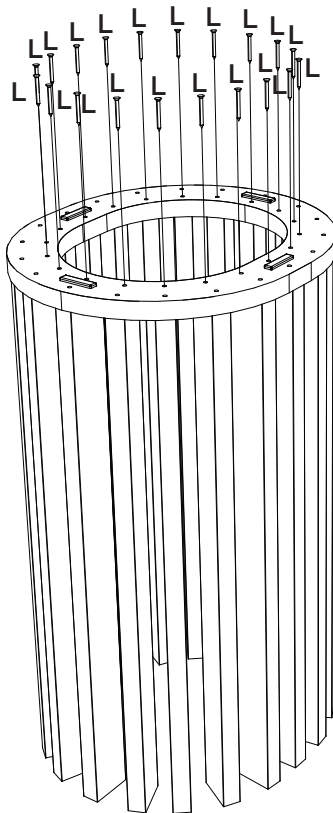
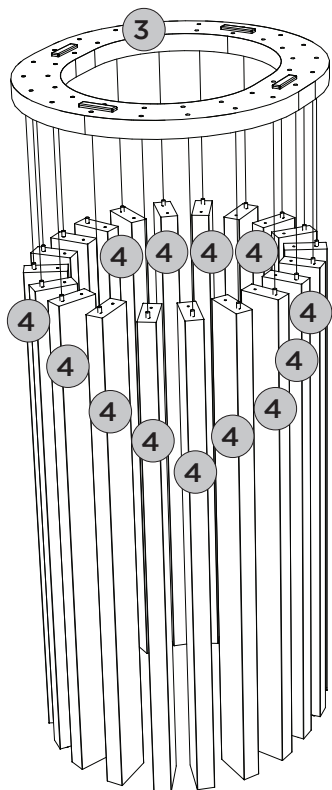
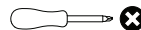

J		
L		20

FERRAMENTAS NECESSÁRIAS

PEÇAS REQUERIDAS

5	TAMPO ESTRUTURAL	x1
---	------------------	----

ACESSÓRIOS REQUERIDOS

A		24
D		01
J		

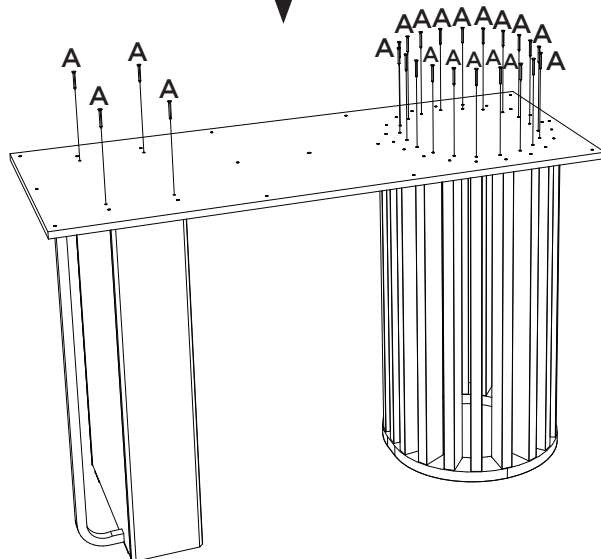
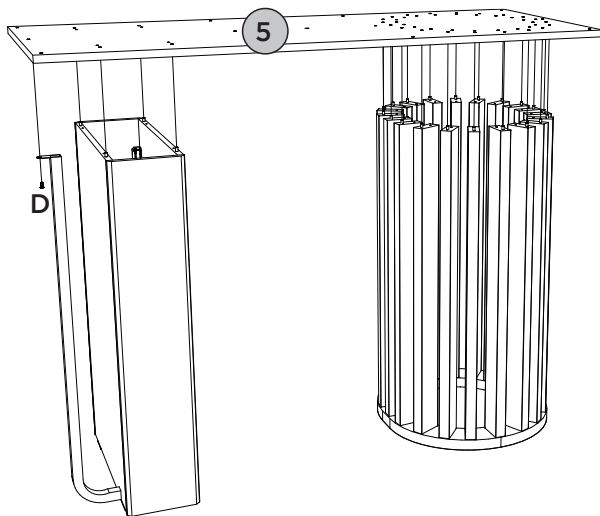
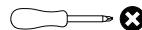
FERRAMENTAS NECESSÁRIAS

Opção de Montagem com o Tampo 2000x900
canto moeda com Vidro (S907-139)

Opción de montaje con parte superior 2000x900
Esquina de monedas con vidrio (S907-139)

Mounting Option with Top 2000x900
Coin corner with Glass (S907-139)

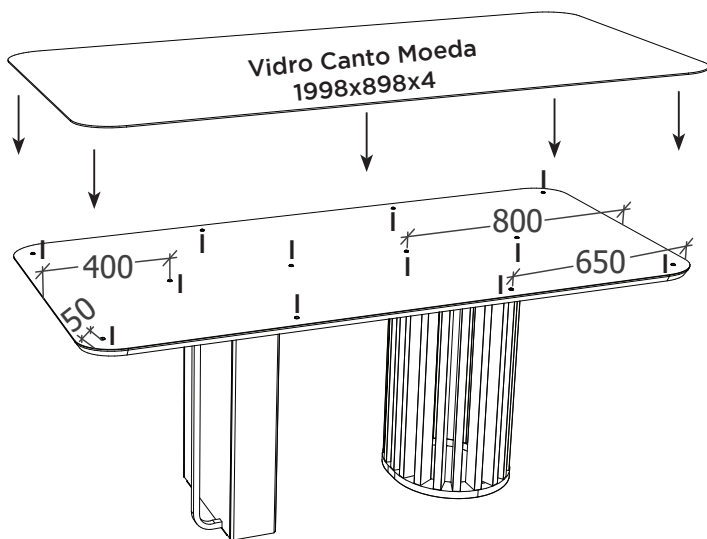
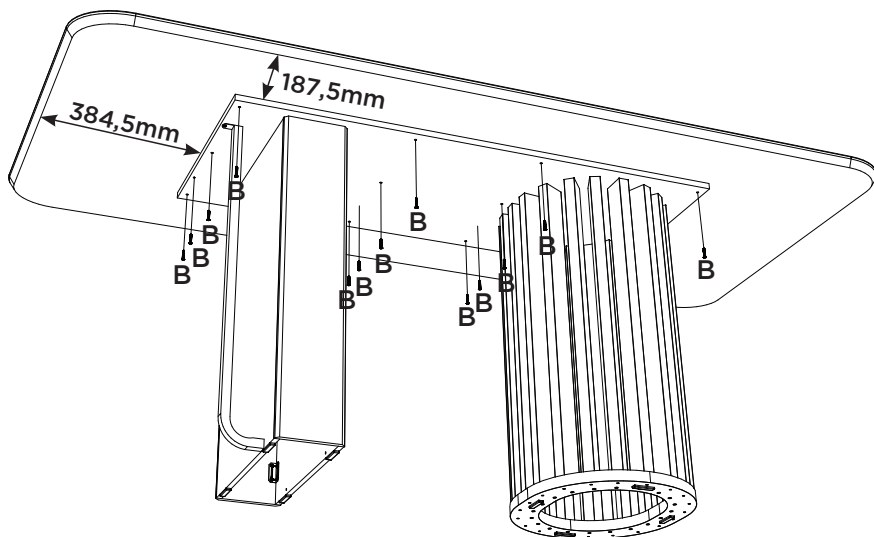

A pintura do Vidro
deve ficar virada
para baixo, depois
ajustá-lo sobre os
batentes de silicone
(I)

La pintura de
vidrio debe mirar
hacia abajo, luego
ajustarla sobre los
topes de silicona (I)

The glass paint
should be facing
downwards, then
adjust it over the
silicone stops (I)

Produto Concluído (S436 + S907)
Producto Terminado (S436 + S907)
Finished Product (S436 + S907)

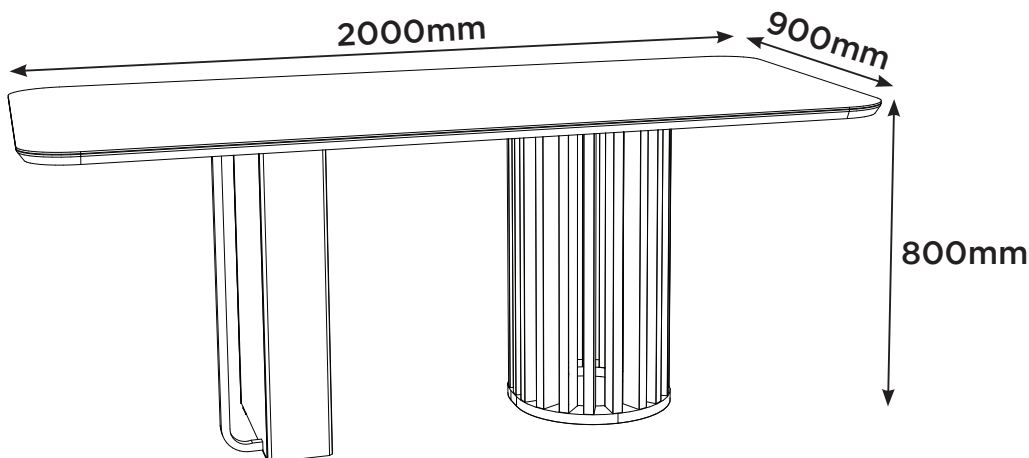

**Opção de Montagem com o Tampo 1600x900
canto reto com Vidro (S908-139)**

**Opción de montaje con parte superior 1600x900
esquina recta con vidrio (S908-139)**

**Mounting Option with Top 1600x900
straight corner with Glass (S908-139)**

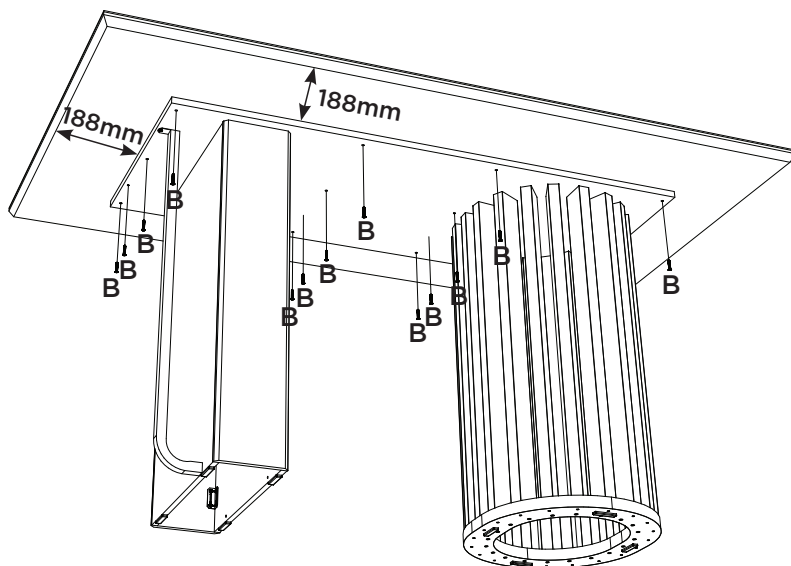

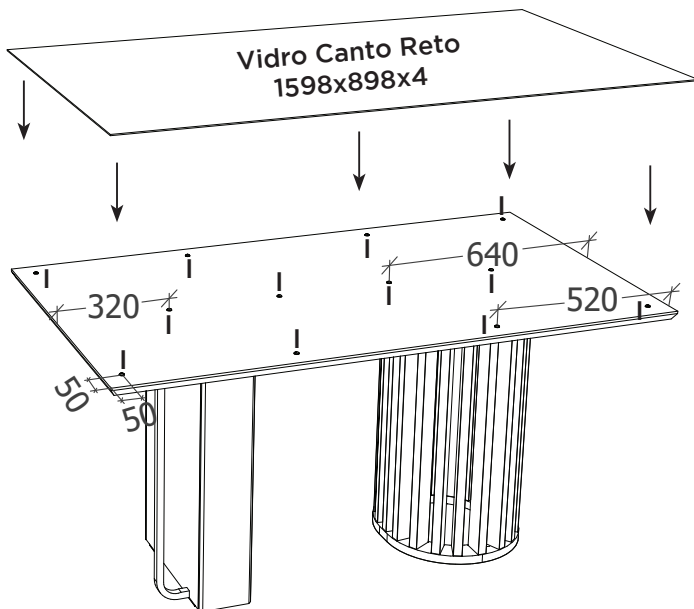

A pintura do Vidro deve ficar virada para baixo, depois ajustá-lo sobre os batentes de silicone (I)

La pintura de vidrio debe mirar hacia abajo, luego ajustarla sobre los topos de silicona (I)

The glass paint should be facing downwards, then adjust it over the silicone stops (I)

Produto Concluído (S436 + S908)
Producto Terminado (S436 + S908)
Finished Product (S436 + S908)

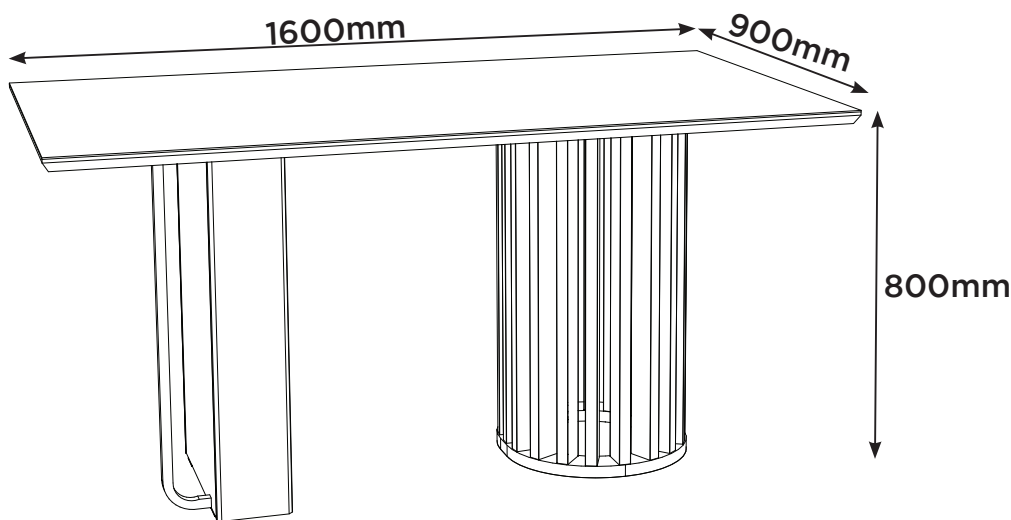

**Opção de Montagem com o Tampo 1600x900
canto moeda com Vidro (S909-139)**

**Opción de montaje con parte superior 1600x900
Esquina de monedas con vidrio (S909-139)**

**Mounting Option with Top 1600x900
Coin corner with Glass (S909-139)**

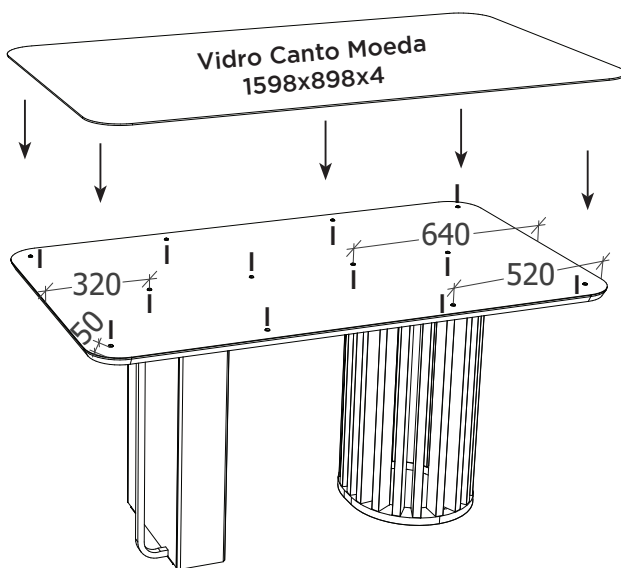
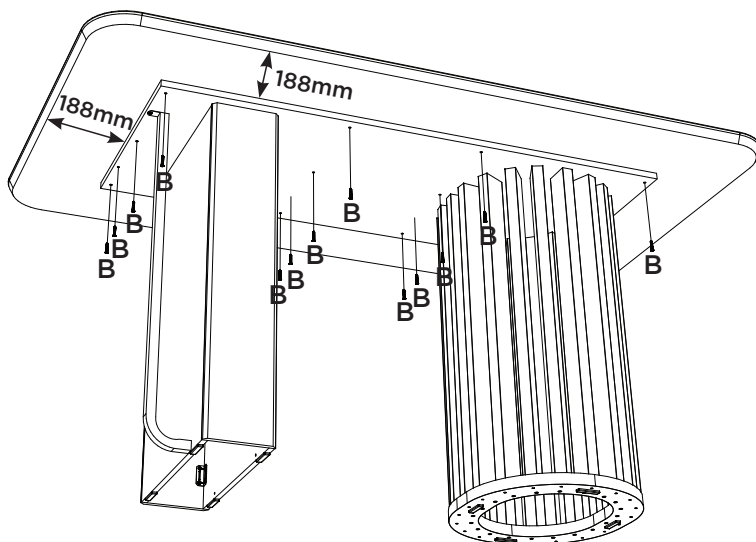

A pintura do Vidro
deve ficar virada
para baixo, depois
ajustá-lo sobre os
batentes de silicone
(I)

La pintura de
vidrio debe mirar
hacia abajo, luego
ajustarla sobre los
topes de silicona (I)

The glass paint
should be facing
downwards, then
adjust it over the
silicone stops (I)

Produto Concluído (S436 + S909)
Producto Terminado (S436 + S909)
Finished Product (S436 + S909)

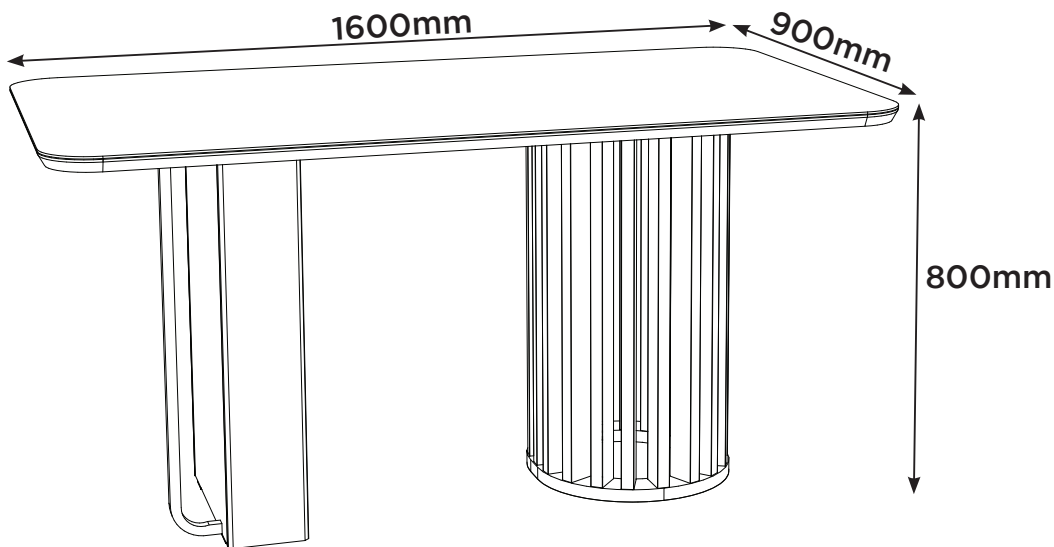

**Opção de Montagem com o Tampo 1600x900
 canto reto sem Vidro (S910-139)**

**Opción de montaje con parte superior 1600x900
 esquina recta sin vidrio (S910-139)**

**Mounting Option with Top 1600x900
 straight corner without Glass (S910-139)**

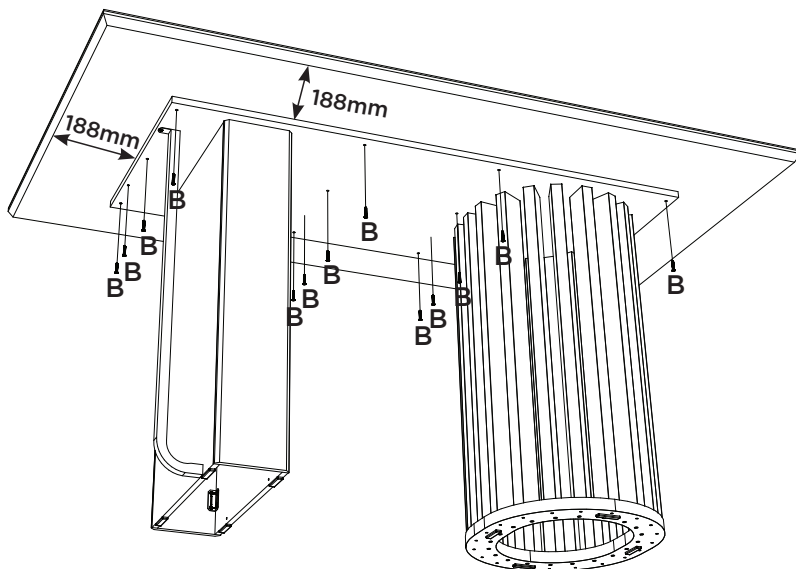

Produto Concluído (S436 + S910)
Producto Terminado (S436 + S910)
Finished Product (S436 + S910)

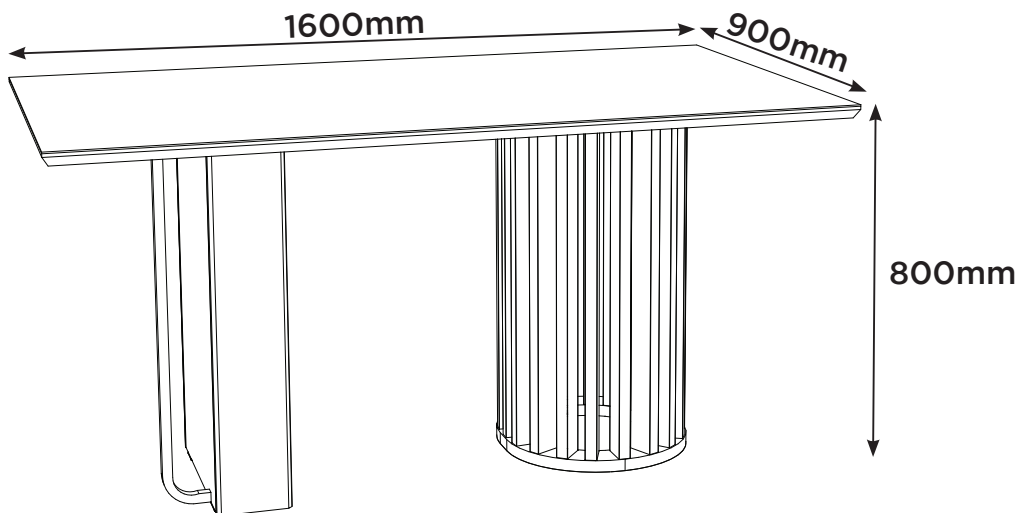

Opção de Montagem com o Tampo 1800x900
canto moeda com Vidro (S922-139)

Opción de montaje con parte superior 1800x900
Esquina de monedas con vidrio (S922-139)

Mounting Option with Top 1800x900
Coin corner with Glass (S922-139)

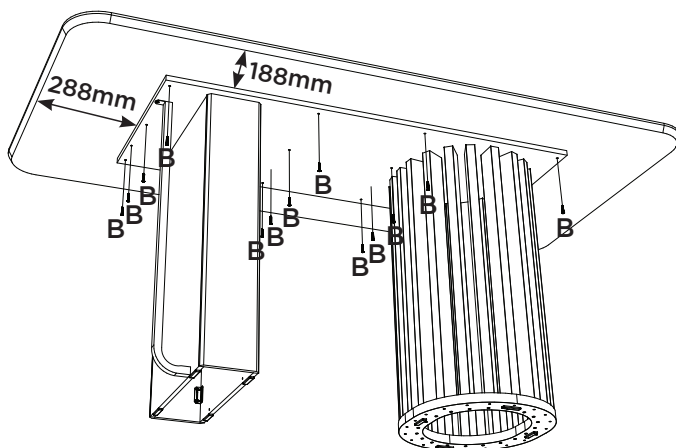

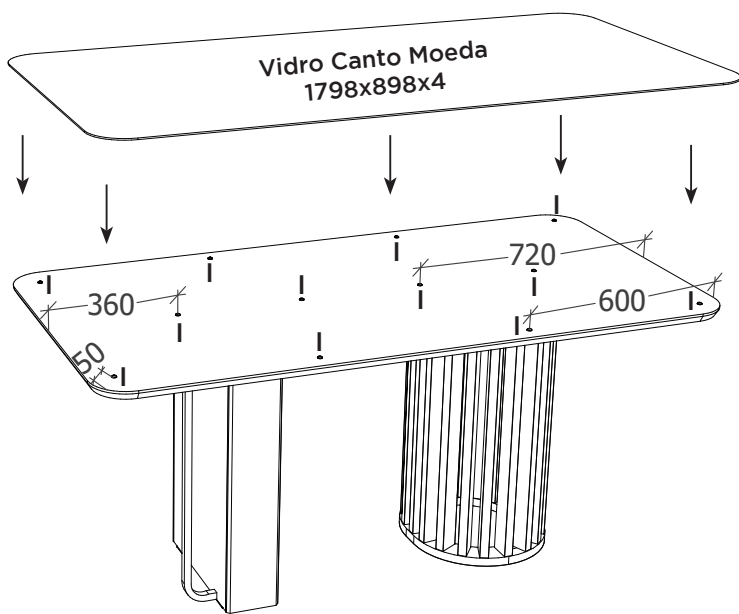

A pintura do Vidro deve ficar virada para baixo, depois ajustá-lo sobre os batentes de silicone (I)

La pintura de vidrio debe mirar hacia abajo, luego ajustarla sobre los toques de silicona (I)

The glass paint should be facing downwards, then adjust it over the silicone stops (I)

Produto Concluído (S436 + S922)
Producto Terminado (S436 + S922)
Finished Product (S436 + S922)

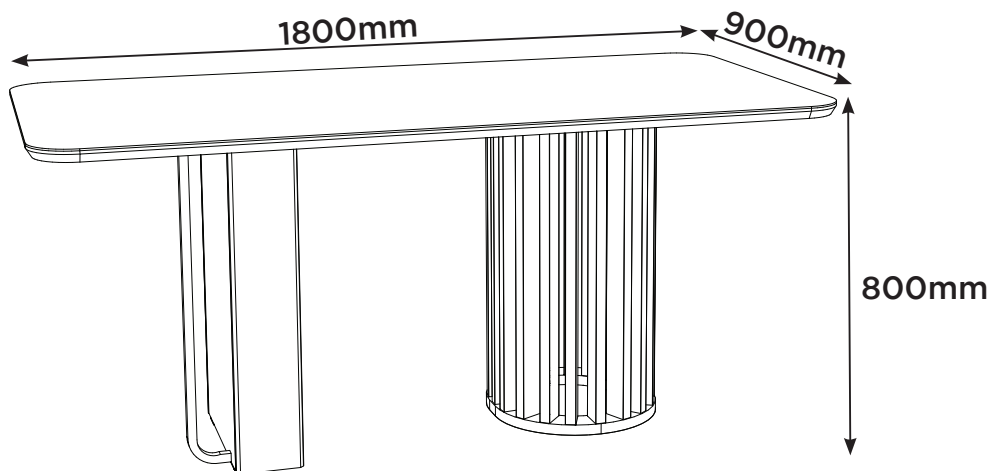

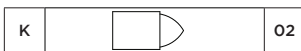

Pesos máximos recomendados con carga distribuída
Peso máximo recomendado con la carga distribuida
Recommended maximum weight with distributed load.

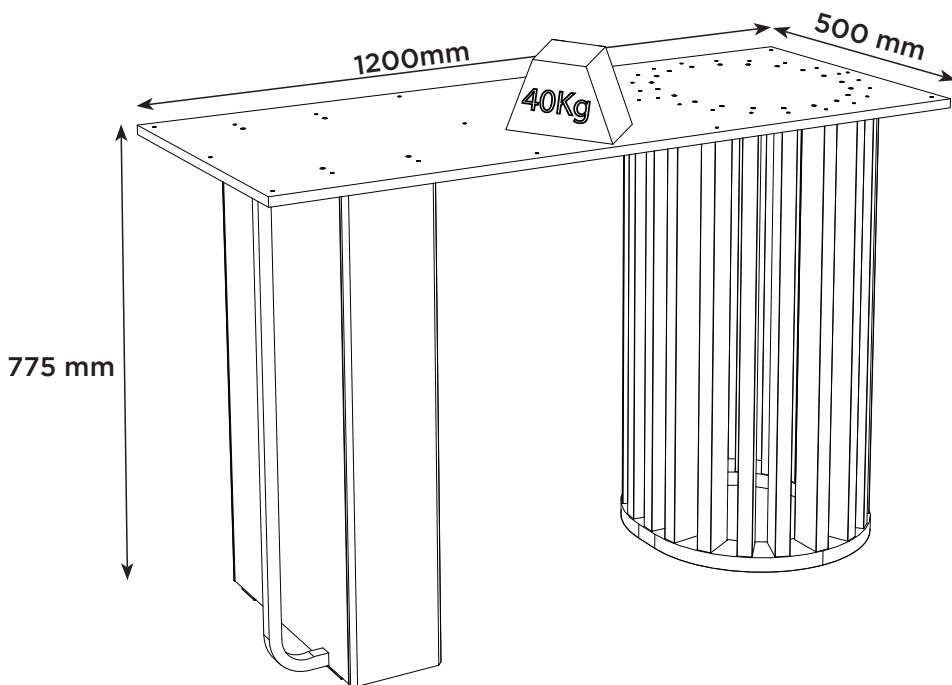

PERFECT CORRECTION
 CORRECCIÓN PERFECTA

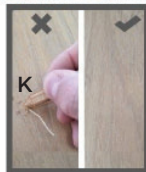

PRODUTO CONCLUÍDO
PRODUCTO TERMINADO
FINISHED PRODUCT

