

# INSTRUÇÕES DE MONTAGEM

INSTRUCCIONES DE MONTAJE  
ASSEMBLY INSTRUCTIONS

## Mesa Luiza 1600mm Sem Vidro

SC16-127 Nature/Off White

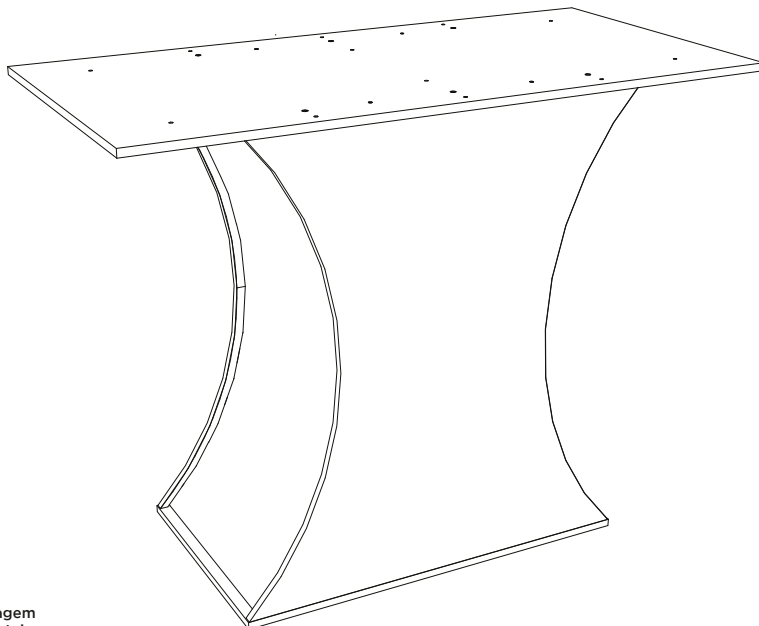

Requisitos para montagem  
Requisitos para la montaje  
Assembly Requirements

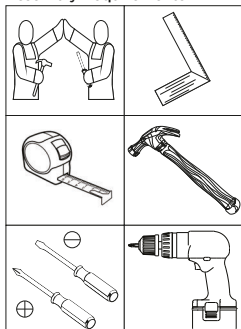

Imagens meramente ilustrativas,  
não acompanha o produto.  
Imágenes ilustrativas, no incluidas  
con el producto.  
Illustrative images, not included  
with the product.

### ASSISTÊNCIA TÉCNICA

Para solicitação de Assistência Técnica você consumidor deverá entrar em contato com o Lojista o qual você realizou a compra deste produto e solicitar a assistência técnica das peças avariadas. A garantia abrange todas as peças, partes e componentes que eventualmente venham apresentar defeito de fabricação no prazo de 03 (três) meses, contando a partir da entrega do produto ao consumidor, mediante nota fiscal de compra.

#### AVISO

Para limpeza de seu móvel, use uma flanela seca ou umedecida, e não utilize produtos químicos que possam danificar seu produto.

#### SISTEMA DE MONTAGEM

O sistema de montagem dos produtos, funciona de acordo com a ordem crescente dos números indicados no desenho. Ex: 01, 02, 03, 04... até a conclusão da montagem.

#### ADVERTENCIA

Para limpieza de su móvil, use una flanela seca o húmeda, y no utilice productos químicos que puedan dañar su producto.

#### SISTEMA DE MONTAJE

El sistema de montaje de los productos funciona de acuerdo con el orden creciente de los números indicados en el dibujo. Ej.: 01, 02, 03, 04... hasta la conclusión del montaje.

#### NOTICE

To clean your furniture, use a dry or wet cloth, and do not use chemicals that may damage your product.

#### ASSEMBLY SYSTEM

The products' assembly system works according to the increasing order of the indicated numbers. For example: 01, 02, 03, 04 ... to the end of the assembly.

## ACESSÓRIOS | ACCESORIOS | ACCESSORIES

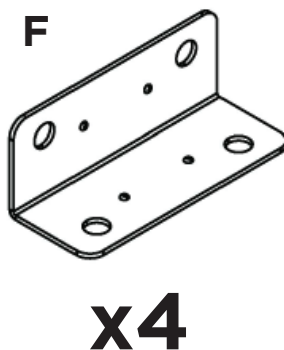
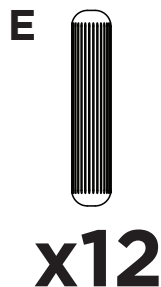
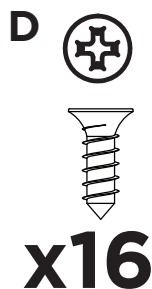
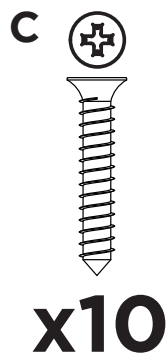
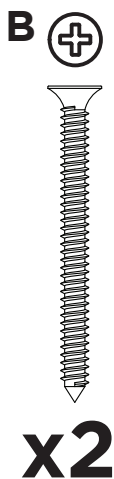
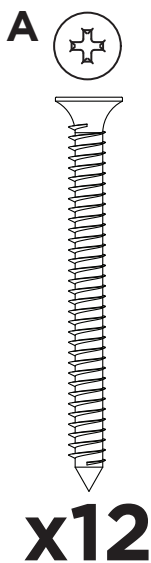

Parafusos em escala  
Tornillos escalados  
Scaled screws

**1:1**

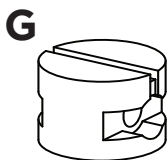

**x12**

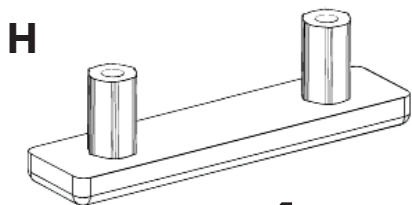

**x4**

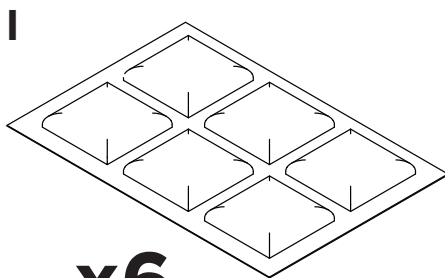

**x6**

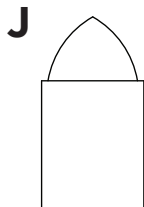

**x2**

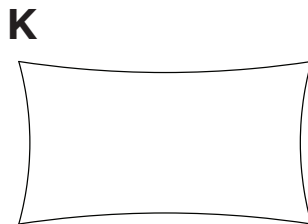

**x2**

## LISTA DE PEÇAS | LISTA DE PIEZAS | LIST OF PIECES

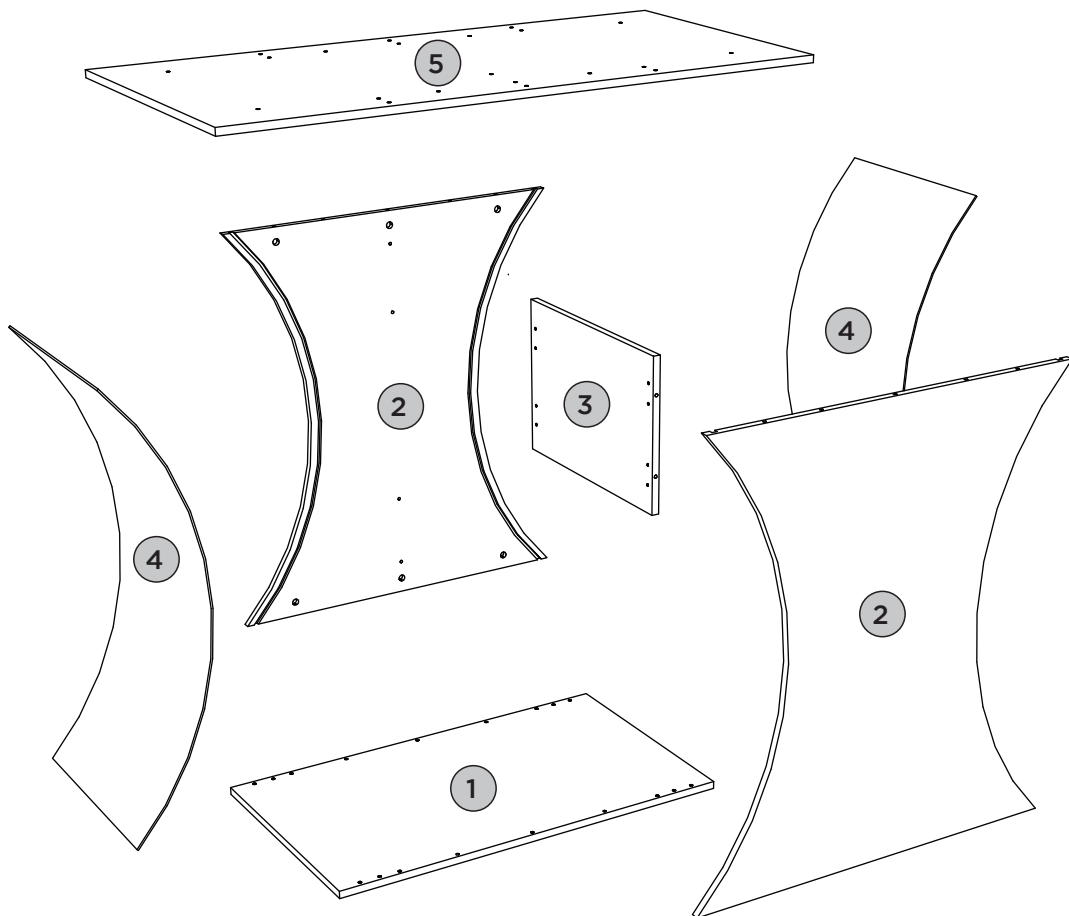



Item	Caixa Caja Box	Qtd Ctd Qty	Descrição Descripción Description	Dimensões (mm)   Dimensiones (mm)   Dimensions (mm)		
				Comprimento Largo Length	Largura Ancho Width	Espessura Grosor Thickness
1	1/1	01	BASE   BASE   BASE	654	384	12
2	1/1	02	LATERAL   LADO   SIDE	742	648	12
3	1/1	01	TRAVESSA ESTRUTURAL   TRAVESAÑO ESTRUTURAL   STRUCTURAL CROSSMEMBER	250	355	12
4	1/1	02	FUNDO   FONDO   BACKGROUND	818	366	3
5	1/1	01	TAMPO ESTRUTURAL   PARTE SUPERIOR ESTRUTURAL   STRUCTURAL TOP	1000	480	12

## PEÇAS REQUERIDAS

1	BASE	x1
---	------	----

## ACESSÓRIOS REQUERIDOS

H		04
K		

## FERRAMENTAS NECESSÁRIAS

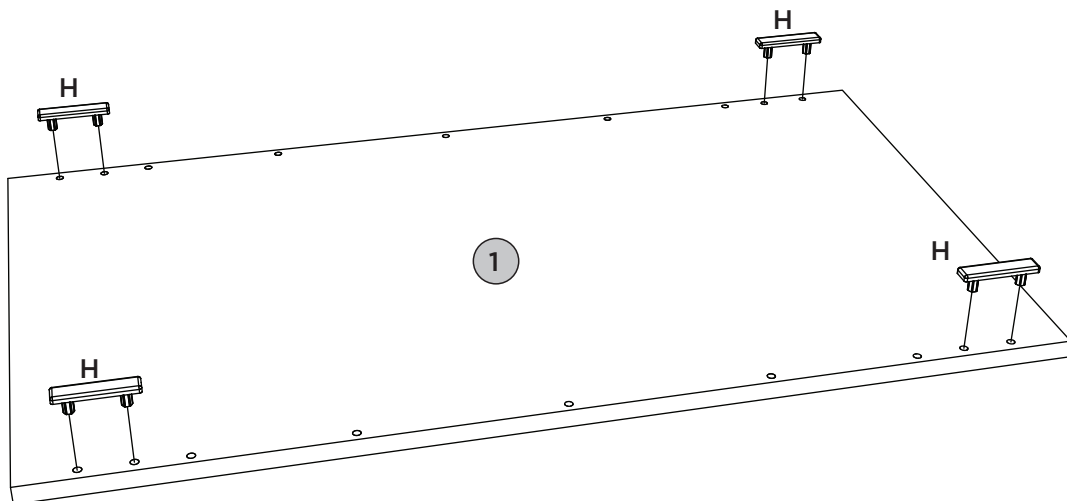
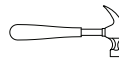

Colocar cola  
para fixação da  
sapata(H).

Ponga pegamento  
para arreglar el  
zapato (H).



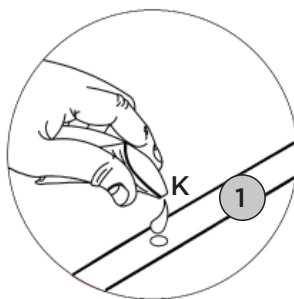

Put glue to fix the  
shoe (H).



**PEÇAS REQUERIDAS**

2	LATERAL	x2
3	TRAVESSA ESTRUTURAL	x1

**ACESSÓRIOS REQUERIDOS**

D		08
E		12
F		04
G		12

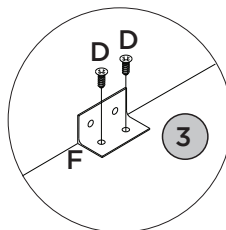
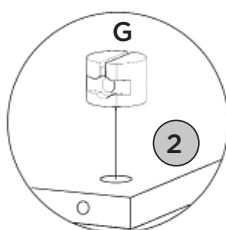
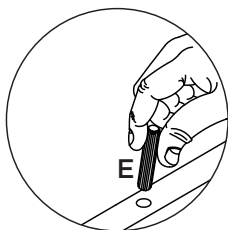
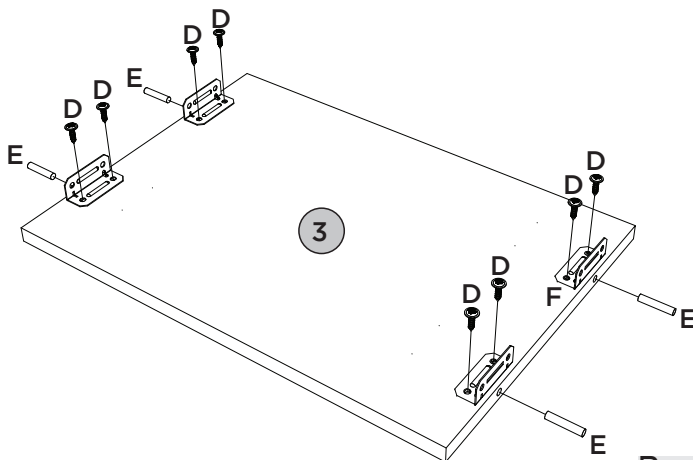
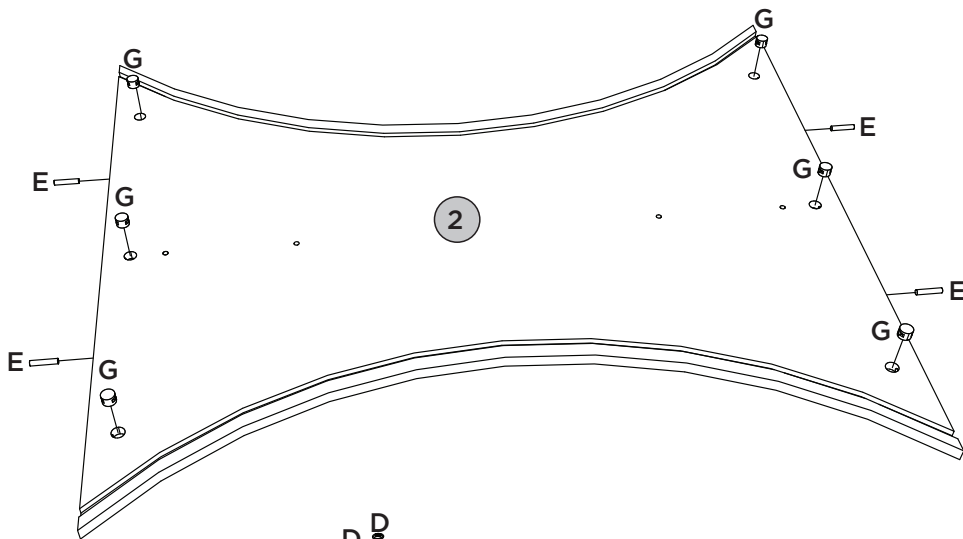
**FERRAMENTAS NECESSÁRIAS**

Peça(3) já com  
pré furações.



Ordene(3) ahora  
con pretaladrado.

Order(3) now  
with pre-drilled.

## PEÇAS REQUERIDAS

1	BASE	x1
2	LATERAL	x2
3	TRAVESSA ESTRUTURAL	x1

## ACESSÓRIOS REQUERIDOS

A		06
D		08

## FERRAMENTAS NECESSÁRIAS

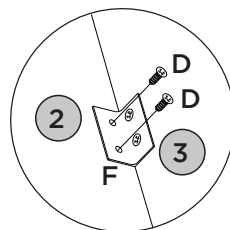
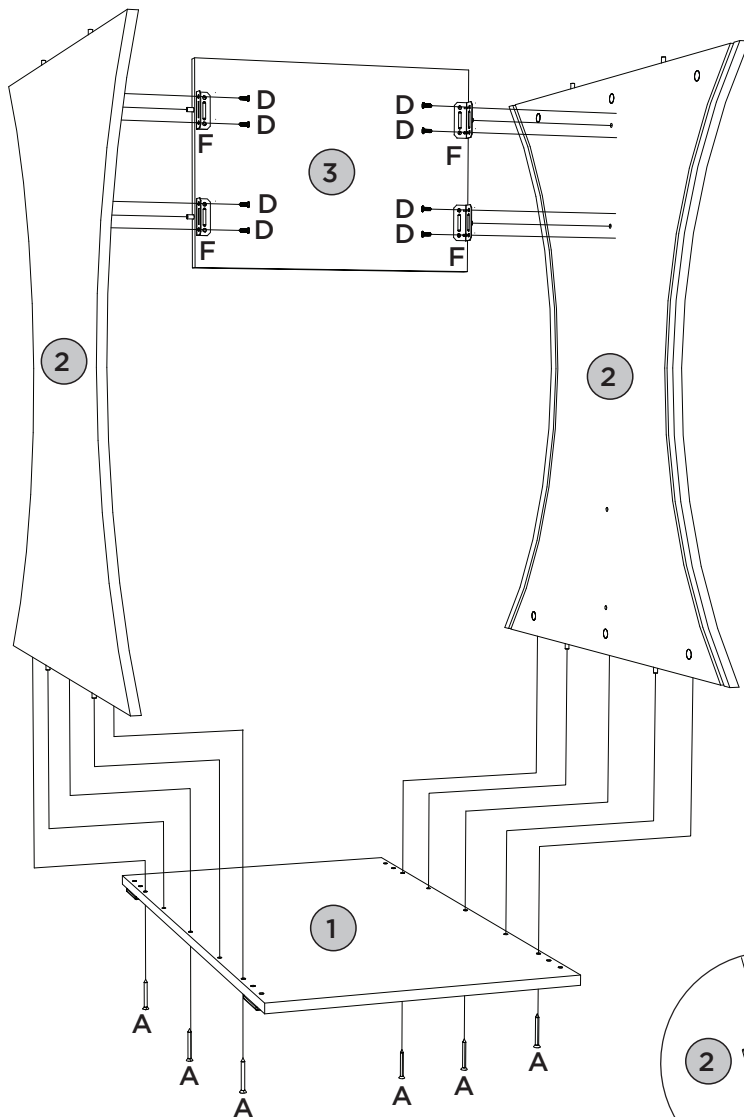
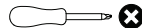



# PASSO 4

ITM/S409-

## PEÇAS REQUERIDAS

4	FUNDO	x2
5	TAMPO ESTRUTURAL	x1

## ACESSÓRIOS REQUERIDOS

A		06
B		02
K		

## FERRAMENTAS NECESSÁRIAS

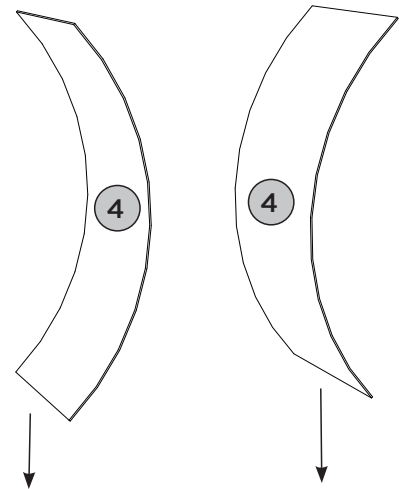
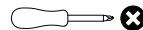

Colocar cola dentro dos frisos das laterais (02) encaixar os fundos (04) e pressioná-los para baixo até ficar na sua posição.

Coloque pegamento dentro de las cenefas en los lados (02), ajuste los fondos (04) y presione hacia abajo hasta que queden en su lugar.

Place glue inside the friezes on the sides (02) fit the bottoms (04) and press them down until they are in position.

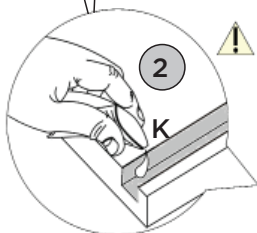
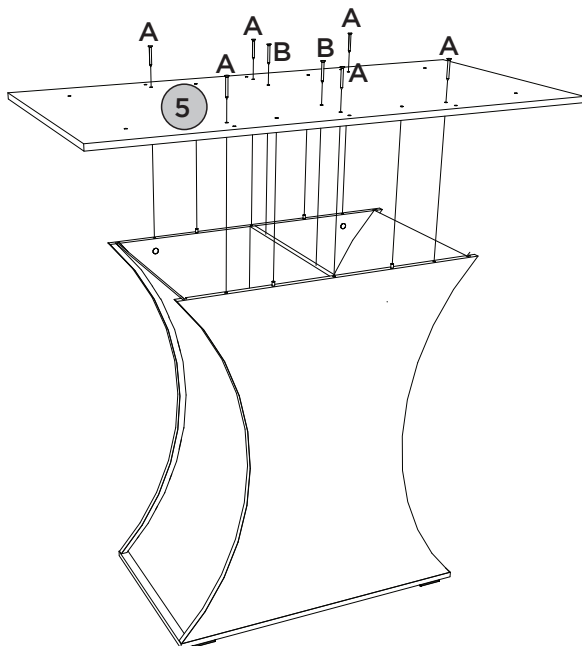
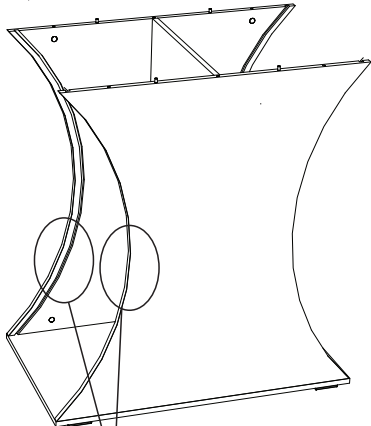





TAMPOS - VENDIDOS SEPARADAMENTE |  
TOPS - SE VENDEN POR SEPARADO |  
TOPS - SOLD SEPARATELY.

Opção de Montagem com o Tampo 1600x900  
canto reto com Vidro (S908-139)

Opción de montaje con parte superior 1600x900  
esquina recta con vidrio (S908-139)

Mounting Option with Top 1600x900  
straight corner with Glass (S908-139)

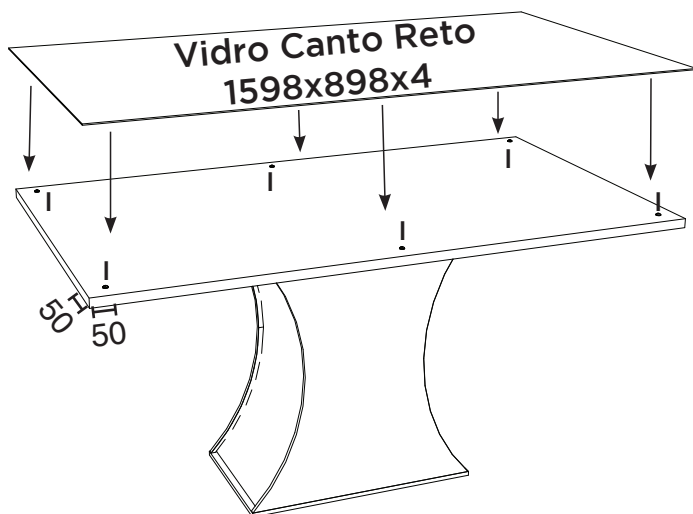
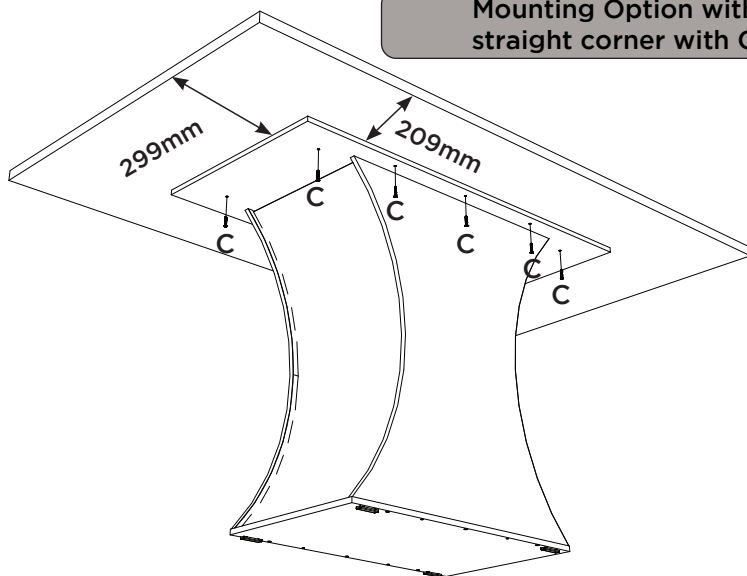

A pintura do Vidro  
deve ficar virada  
para baixo, depois  
ajustá-lo sobre os  
batentes de silicone  
(I).

La pintura de  
vidrio debe mirar  
hacia abajo, luego  
ajustarla sobre los  
topes de silicona  
(I).

The glass paint  
should be  
facing downwards,  
then adjust it over  
the silicone  
stops  
(I).

**Produto Concluído (S409 + S908)**  
**Producto Terminado (S409 + S908)**  
**Finished Product (S409 + S908)**

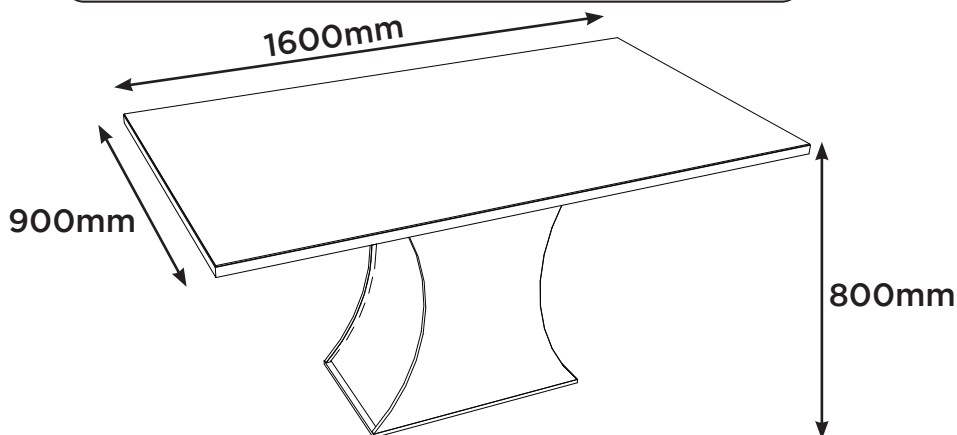

## PASSO 6

**Opção de Montagem com o Tampo 1600x900  
canto moeda com Vidro (S909-139)**

**Opción de montaje con parte superior 1600x900  
Esquina de monedas con vidrio (S909-139)**

**Mounting Option with Top 1600x900  
Coin corner with Glass (S909-139)**

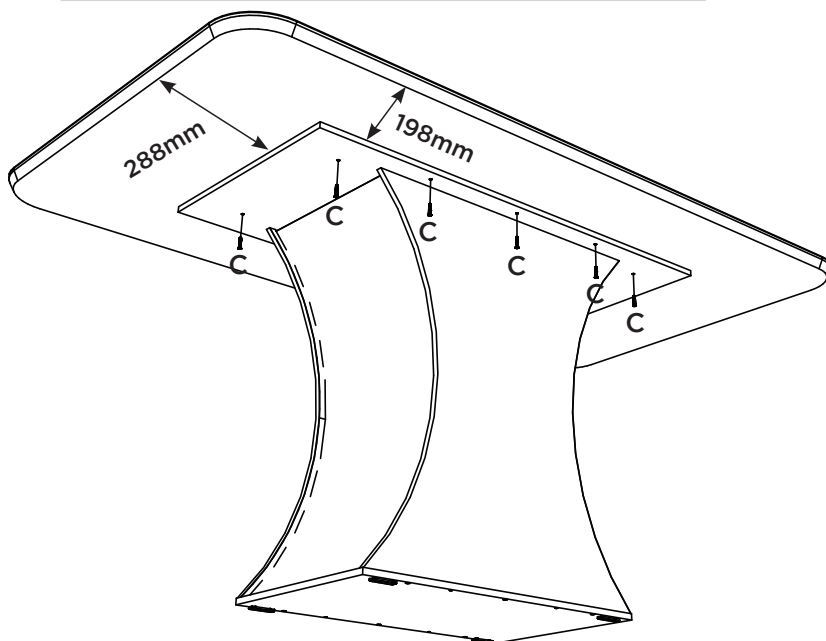

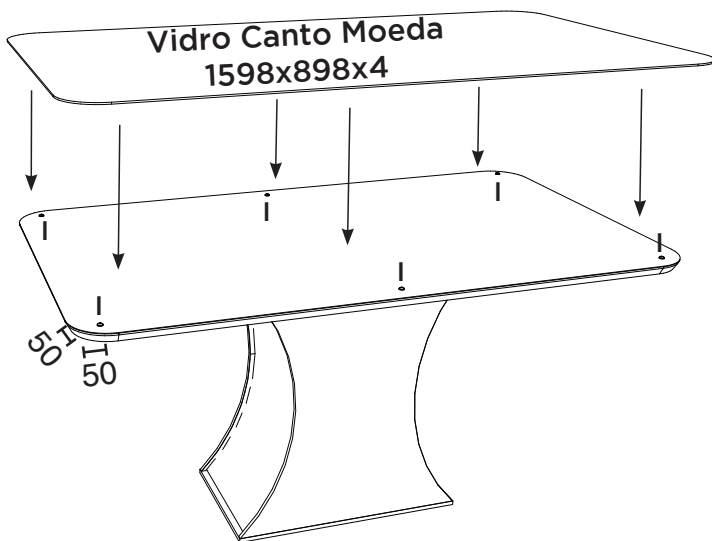

A pintura do Vidro deve ficar virada para baixo, depois ajustá-lo sobre os batentes de silicone (I).

La pintura de vidrio debe mirar hacia abajo, luego ajustarla sobre los topes de silicona (I).

The glass paint should be facing downwards, then adjust it over the silicone stops (I).

Produto Concluído (S409 + S909)  
Producto Terminado (S409 + S909)  
Finished Product (S409 + S909)

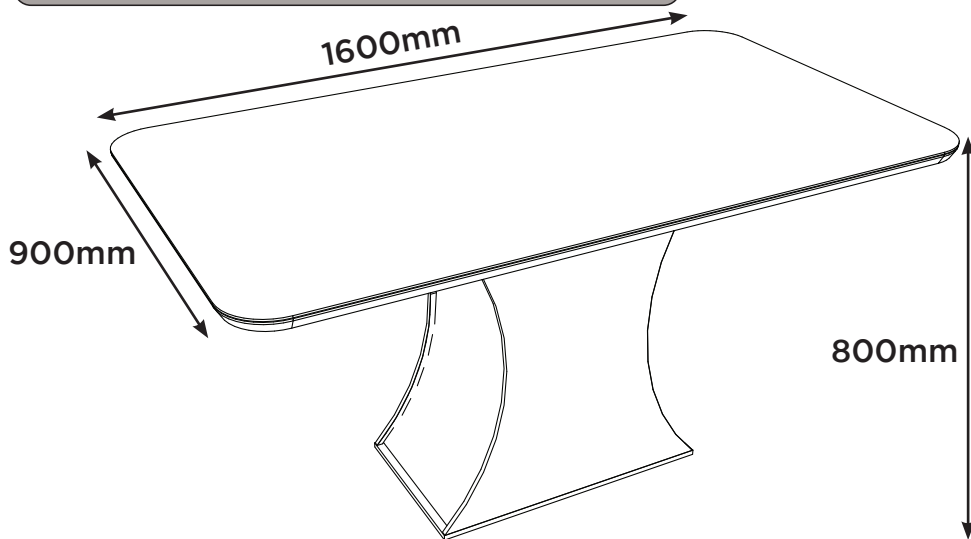

Opção de Montagem com o Tampo 1600x900  
canto reto sem Vidro (S910-139)

Opción de montaje con parte superior 1600x900  
esquina recta sin vidrio (S910-139)

Mounting Option with Top 1600x900  
straight corner without Glass (S910-139)

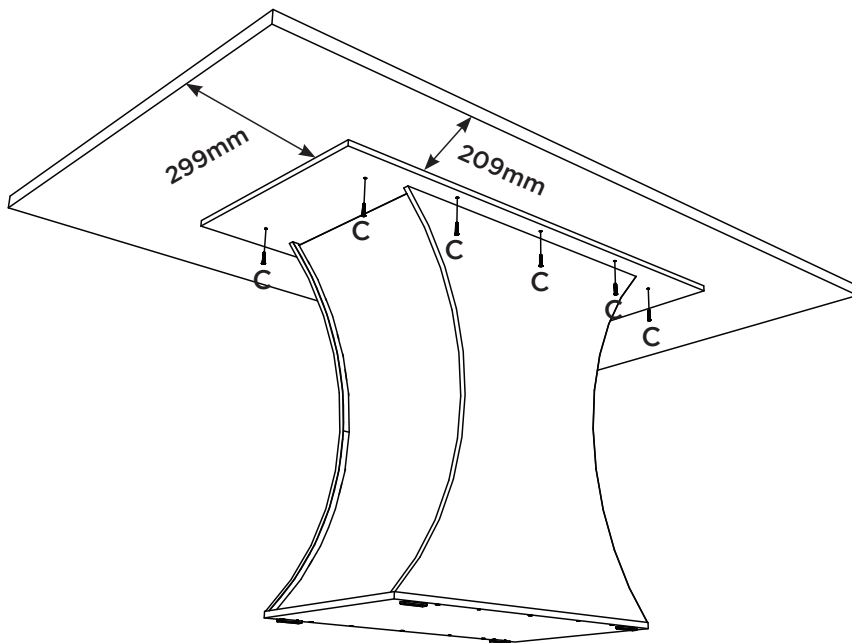

Produto Concluído (S409 + S910)  
Producto Terminado (S409 + S910)  
Finished Product (S409 + S910)

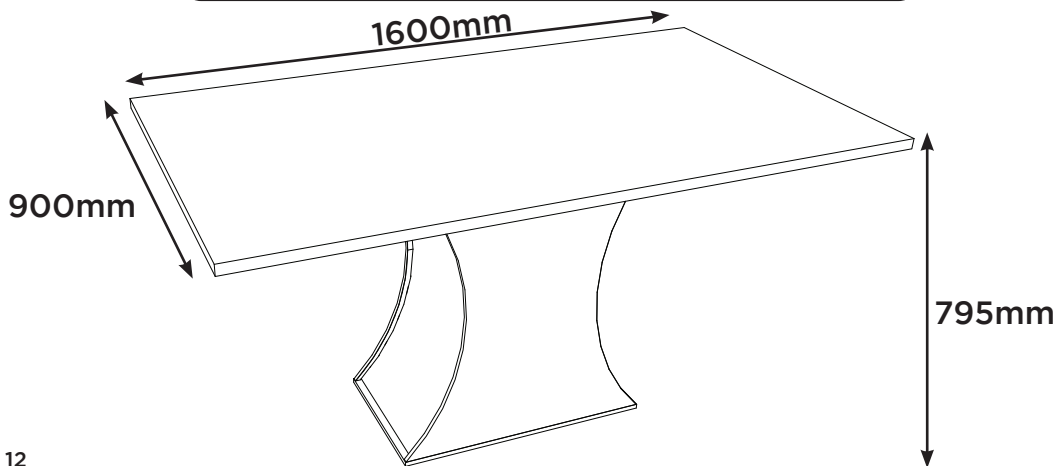

Opção de Montagem com o Tampo 1200x800  
canto reto sem Vidro (S916-139)

Opción de montaje con parte superior 1200x800  
esquina recta sin vidrio (S916-139)

Mounting Option with Top 1200x800  
straight corner without Glass (S916-139)

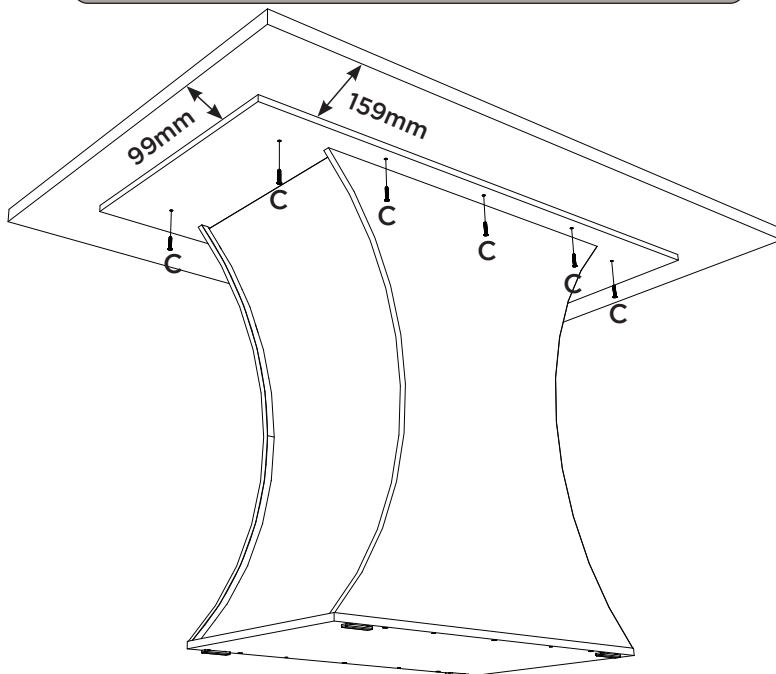

Produto Concluído (S409 + S916)  
Producto Terminado (S409 + S916)  
Finished Product (S409 + S916)

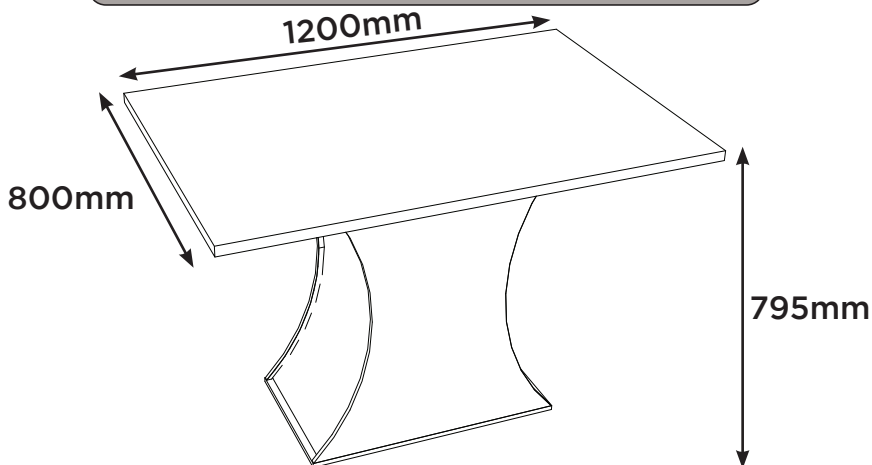

Opção de Montagem com o Tampo 1200x800  
canto reto com Vidro (S914-139)

Opción de montaje con parte superior 1200x800  
esquina recta con vidrio (S914-139)

Mounting Option with Top 1200x800  
straight corner with Glass (S914-139)

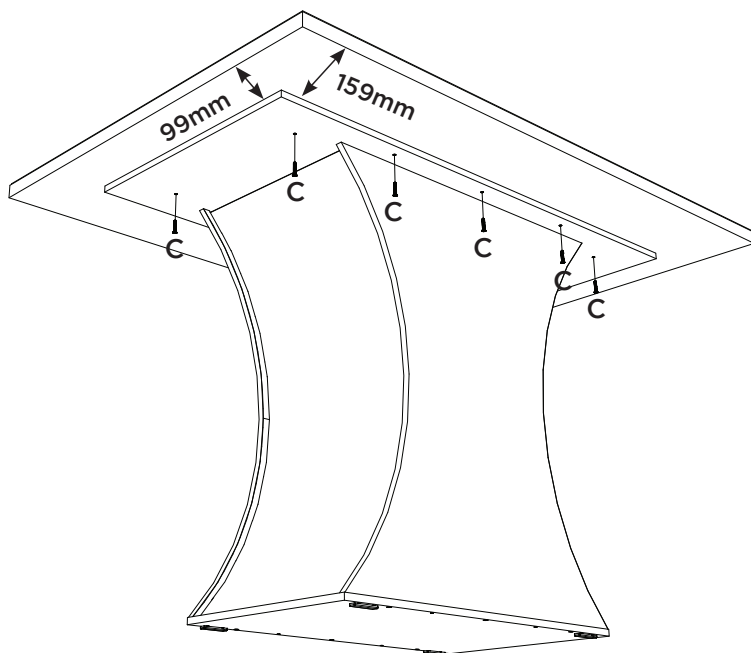

Vidro Canto Reto  
1198x798x4

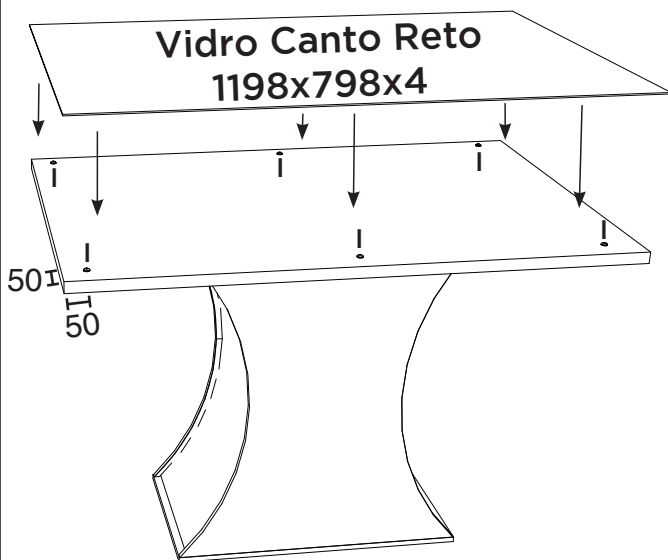

A pintura do Vidro  
deve ficar virada  
para baixo, depois  
ajustá-lo sobre os  
batentes de silicone  
(i).

La pintura de  
vidrio debe mirar  
hacia abajo, luego  
ajustarla sobre los  
topes de silicona  
(i).

The glass paint  
should be  
facing downwards,  
then adjust it over  
the silicone stops  
(i).

**Produto Concluído (S409 + S914)**  
**Producto Terminado (S409 + S914)**  
**Finished Product (S409 + S914)**

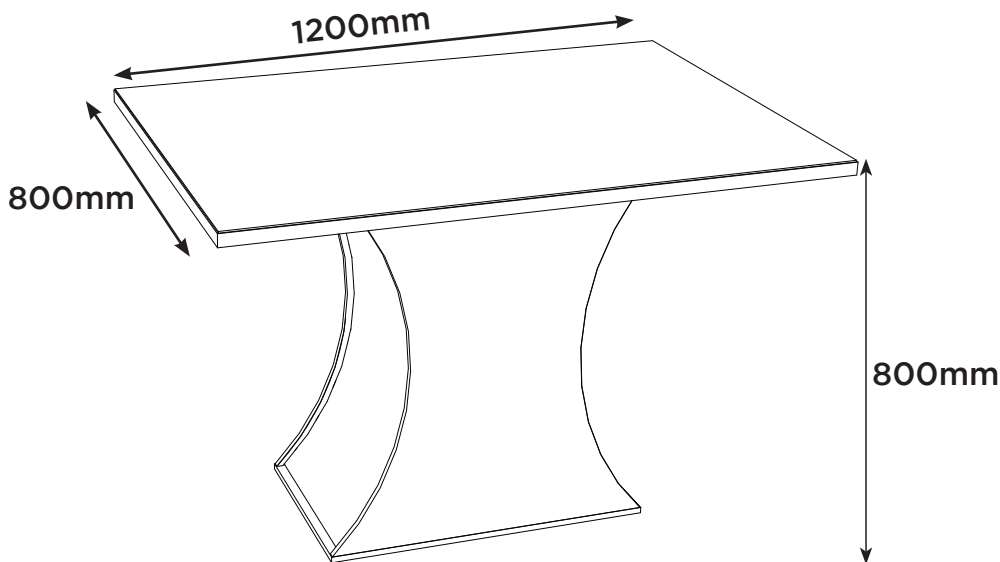

**Pesos máximos recomendados com carga distribuída**  
**Peso máximo recomendado con la carga distribuida**  
**Recommended maximum weight with distributed load.**

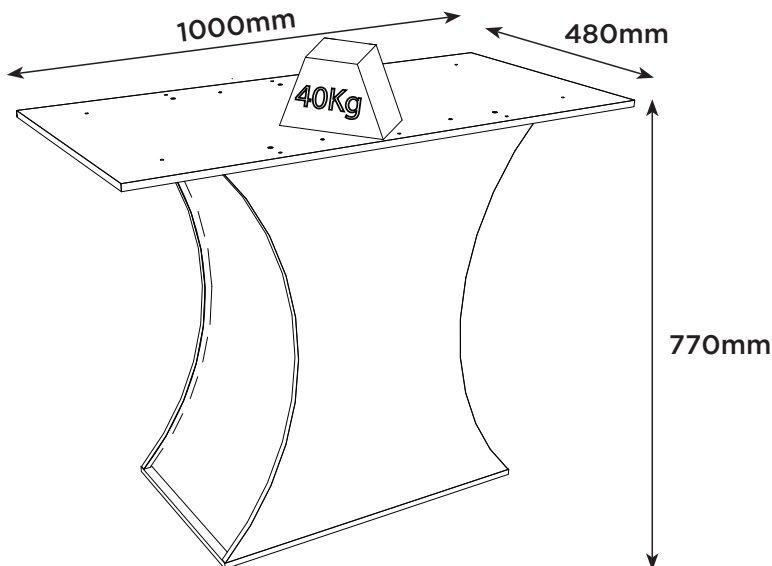

**Produto Concluído**  
**Producto terminado**  
**Finished Product**

