

Estação Diretoria com Connect Linha Executiva

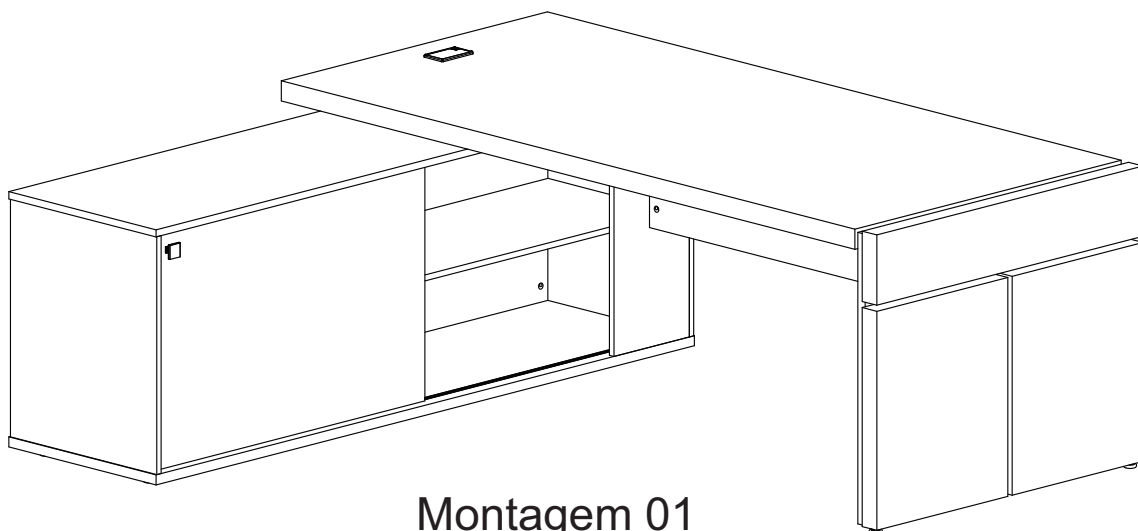

Montagem 01

Montaje 01 / Installation 01

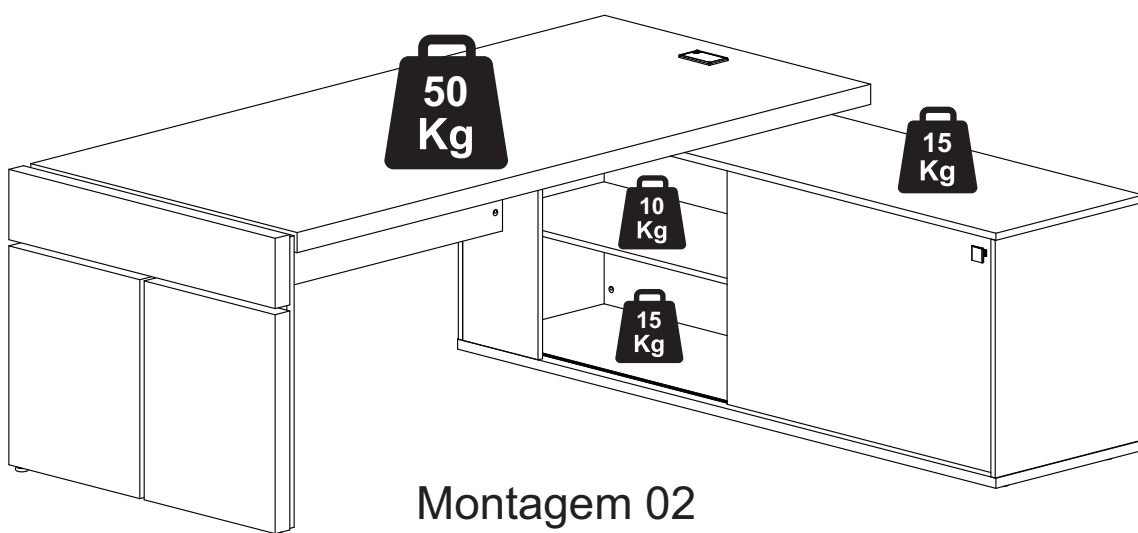

Montagem 02

Montaje 02 / Installation 02

ARTANY[®]
Arte em Home Office

Conheça outros produtos da nossa empresa no site: www.artany.com.br

Conozca otros productos en el sitio: www.artany.com.br

Know another products in: www.artany.com.br

- Siga atentamente todas as instruções de montagem;
- Monte seu produto no local ou próximo de onde será colocado. Movimentações do produto já montada, podem avariá-lo;
- Faça a montagem em uma superfície limpa e plana. Aconselhamos usar a própria embalagem de papelão para forrar o chão;
- Verifique se as quantidades de peças e acessórios estão de acordo com o manual de montagem;
- Compare atentamente os furos de cada peça com a ilustração do manual;
- Utilize as ferramentas indicadas. Só utilize parafusadeira se tiver conhecimento e habilidade. O uso inapropriado pode danificar peças e/ou acessórios;
- Se o produto necessitar fixação na parede, tenha cuidado para não atingir fios e canos ao furar a parede.

Obs: Caso necessite solicitar peças de reposição, por favor, utilize os códigos dos mesmos.

- Siga con atención todas las instrucciones de armado.
- Arme su mueble en un lugar cerca donde será instalado. Mover el producto ya montado puede perjudicarlo.
- Haga el montaje en una superficie limpia y plana. Aconsejamos usar el propio embalaje de cartón para forrar el suelo.
- Asegúrese de que las cantidades de piezas y accesorios coincidan con el manual de montaje.
- Compare cuidadosamente los agujeros de cada pieza con la ilustración del manual.
- Utilice las herramientas indicadas. Sólo utilice atornillador automático si tiene conocimiento y habilidad. El uso inapropiado puede dañar piezas y/o accesorios.
- Si el producto necesita fijación en la pared, tenga cuidado de no alcanzar cables y tuberías al perforar la pared.

OBS: Si necesita solicitar piezas y / o accesorios de repuesto, por favor, utilice los códigos de los mismos.

- Follow carefully the assembly instructions.
- Assemble your furniture in a place near where it will be installed. Moving the assembled product can harm it.
- Make the assembly on a clean and flat surface. We recommend using the cardboard box to cover the floor.
- Make sure the quantities of parts and accessories match the assembly manual.
- Carefully compare the holes in each piece with the illustration in the manual.
- Use the indicated tools. Only use an automatic screwdriver if you have knowledge and skill. Improper use can damage parts and/or accessories.
- If the product needs fixing on the wall, be careful and don't reach cables and pipes when drilling the wall.

NOTE: If you need to request spare parts and/or accessories, please use the codes according of this instruction manual.

CONSERVAÇÃO E LIMPEZA

MANTENIMIENTO Y LIMPIEZA / MAINTENANCE AND CLEANING

Não expor o produto ao sol, altas temperaturas e umidade, mantendo-o em local seco e arejado. Para a limpeza, utilizar um pano seco e macio. Não é necessário o uso de materiais abrasivos ou álcool.

No exponga el producto al sol, altas temperaturas y la humedad. Mantener en local seco y ventilado. Para limpiar, utilice un paño suave y seco. No es necesario el uso de materiales abrasivos o alcohol.

Do not expose the product to sunlight, high temperatures and humidity. Keep it in a dry and ventilated place. To clean it, use a soft and dry cloth. It is not necessary to use abrasive materials or alcohol.

Garantia

Este certificado de Garantia é uma vantagem adicional oferecida ao consumidor, porém para que o mesmo tenha validade é imprescindível que seja apresentada a NOTA FISCAL de compra do produto e o número do lote (ver etiqueta).

Com este produto, a **Artany** tem como objetivo atender plenamente o proprietário-consumidor, proporcionando a garantia na forma aqui estabelecida, pelo período de 03 meses a partir da data da nota fiscal de compra. A **Artany** restringe a sua responsabilidade à substituição gratuita das peças defeituosas, em caso de defeitos ou avarias devidamente constatados como sendo de fabricação, durante a vigência desta garantia.

A **Artany** declara a garantia nula e sem efeito se o produto for alterado, adulterado, molhado ou consertado e ainda pela prática de montagem inadequada. Também será considerada nula em casos de força maior, como aqueles causados por agentes da Natureza (chuvas, incêndios, excesso de umidade...).

Para exercer seus direitos de comprador é importante que antes de montar seu produto você leia com atenção as instruções de cada passo do manual de montagem que acompanha o móvel.







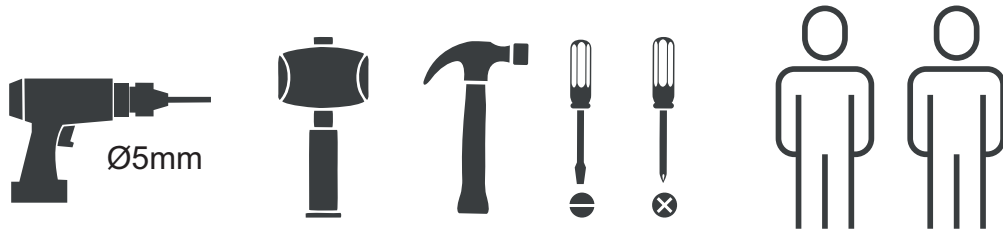

Caso o produto não esteja em conformidade, entre em contato com a loja onde efetuou a compra ou com o nosso Serviço de Atendimento ao Cliente através do fone (41) 3556 1500 ou do e-mail assistencia@artany.com.br, e faça sua reclamação, apontando os defeitos técnicos observados, que teremos o maior prazer em atendê-lo. Para agilizar o seu atendimento, tenha sempre em mãos o manual de montagem com os respectivos números das peças defeituosas conforme descritas no manual.

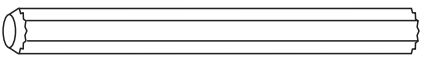
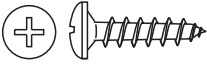
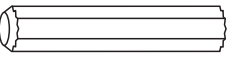
FERRAMENTAS **NÃO** FORNECIDAS, MAS NECESSÁRIAS
PARA A MONTAGEM DO PRODUTO

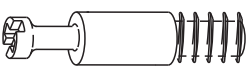
HERRAMIENTAS **NO** SUMINISTRADAS, PERO NECESARIAS PARA EL MONTAJE DEL PRODUCTO
TOOLS **NOT** SUPPLIED, BUT NECESSARY FOR THE ASSEMBLY

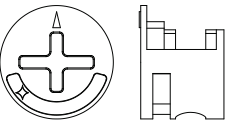
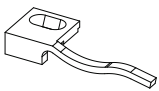
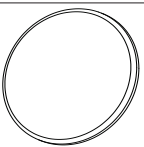

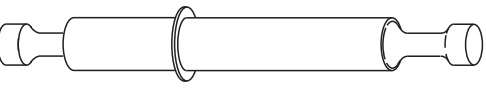
LISTA DE MATERIAIS
LISTA DE MATERIALES
HARDWARE LIST

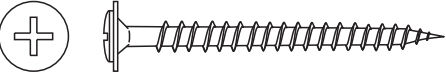
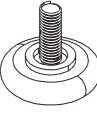
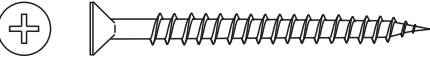
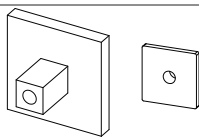
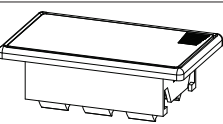
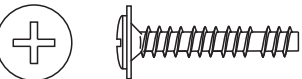
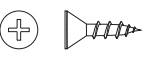
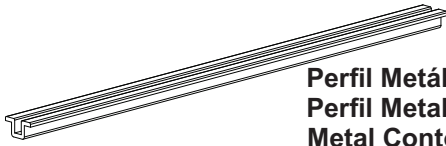
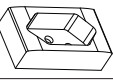
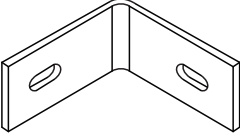
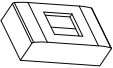
A	 Cavilha / Tarugo / Dowel Ø6x55mm	2x	J	 Parafuso / Tornillo / Screw Ø4,0x16mm CP	18x	
B	 Cavilha Tarugo / Dowel Ø6x30mm	28x	K Kit porta de correr Kit Puerta Deslizante Sliding Door Kit	K₁	 Guia Guía Guide	2x
C	 Minifix Minifix / Minifix Ø7x32mm	22x		K₂	 Roldana Polea Pulley	2x
D	 Tambor Tambor / Minifix Cam Ø15x12mm	24x		K₃	 Freio Esquerdo Freno Izquierdo Left Brake	1x
E	 Tapa furo adesivo Adhesivo / Hole Cover Ø18mm	30x		K₄	 Freio Direito Freno Derecho Right Brake	1x
F	 Haste Dupla Minifix / Minifix Doble Varilla / Double Rod Minifix Ø7x60mm	1x		L	 Bucha sapata Buje pata / Foot bushing	8x
G	 Parafuso / Tornillo / Screw Ø4,0x45mm CF	9x	M	 Sapata Pata Foot	8x	
H	 Parafuso / Tornillo / Screw Ø4,0x45mm CC	10x	N₁	 Puxador Tirador Handle	1x	
I	I₁  Caixa de Tomadas Caja de Enchufe Electrical Outlet	1x	N₂	 Parafuso Puxador Tornillo Tirador / Handle Screw	1x	
	I₂  Parafuso Tornillo Screw Ø3,0x10mm CC	2x	O	 Perfil Metálico Perfil Metalico Metal Contour 1795mm	2x	
	I₃  Tomada 10a 10a salida 10a outlet	2x	P	 Cantoneira Cantonera Corner Brace 26x26mm	2x	
	I₄  Conector RJ45 Conector RJ45 RJ45 connector	1x				

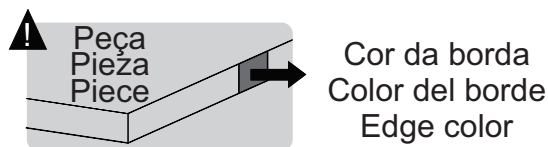

Azul (Lateral direita)
 Vermelho (Lateral esquerda)
 Preto (Divisão direita)
 Verde (Divisão esquerda)

Azul (Lateral derecho)
 Rojo (Lateral izquierda)
 Negro (División derecha)
 Verde (División izquierda)

Blue (Right side)
 Red (Left side)
 Black (Right partition)
 Green (Left partition)

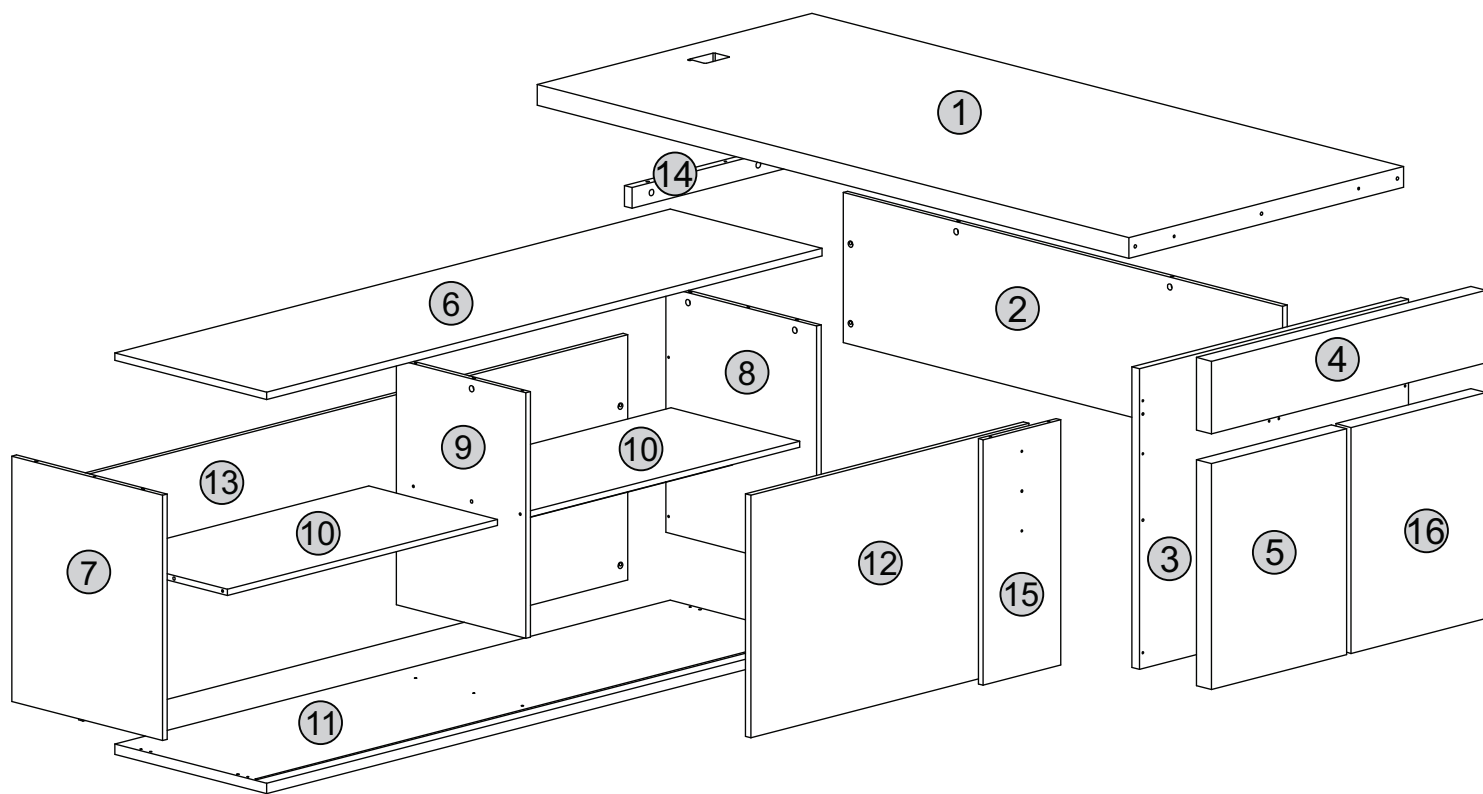

Descrição	Descripción	Description	Qty
1-Tampo (1950x905x50mm)	1-Tapa	1-Top	1
2-Travessa (1448x362x15mm)	2-Travesaño	2-Crosspiece	1
3-Lateral interna (725x886x25mm)	3-Lado interno	3-Inner side	1
4-Lateral superior (175x905x50mm)	4-Lado superior	4-Upper side	1
5-Lateral esquerda (545x445x50mm)	5-Lado izquierdo	5-Left side	1
6-Tampo balcão (1830x500x18mm)	6-Tapa balcón	6-Top	1
7-Lateral esquerda balcão (592x497x15mm)	7-Lado izquierdo balcón	7-Left side	1
8-Lateral direita balcão (592x497x15mm)	8-Lado derecho balcón	8-Right side	1
9-Divisão (592x427x15mm)	9-División	9-Partition	1
10-Prateleira (890x424x15mm)	10-Anaqueil	10-Shelf	2
11-Base (1830x500x25mm)	11-Base	11-Base	1
12-Porta (585x916x18mm)	12-Puerta	12-Door	1
13-Traseira (1795x592x15mm)	13-Trasero	13-Back	1
14-Travessa balcão (50x512x25mm)	14-Travesaño balcón	14-Small crosspiece	1
15-Divisória travessa (592x256x15mm)	15-Travesaño división	15-Crosspiece division	1
16-Lateral direita (545x445x50mm)	16-Lado derecho	16-Right side	1

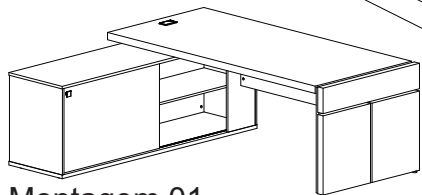
1

Montagem 01
Montaje 01 / Installation 01

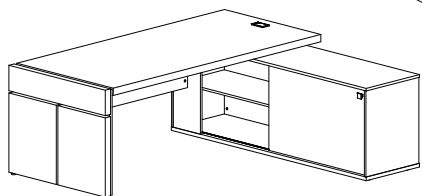
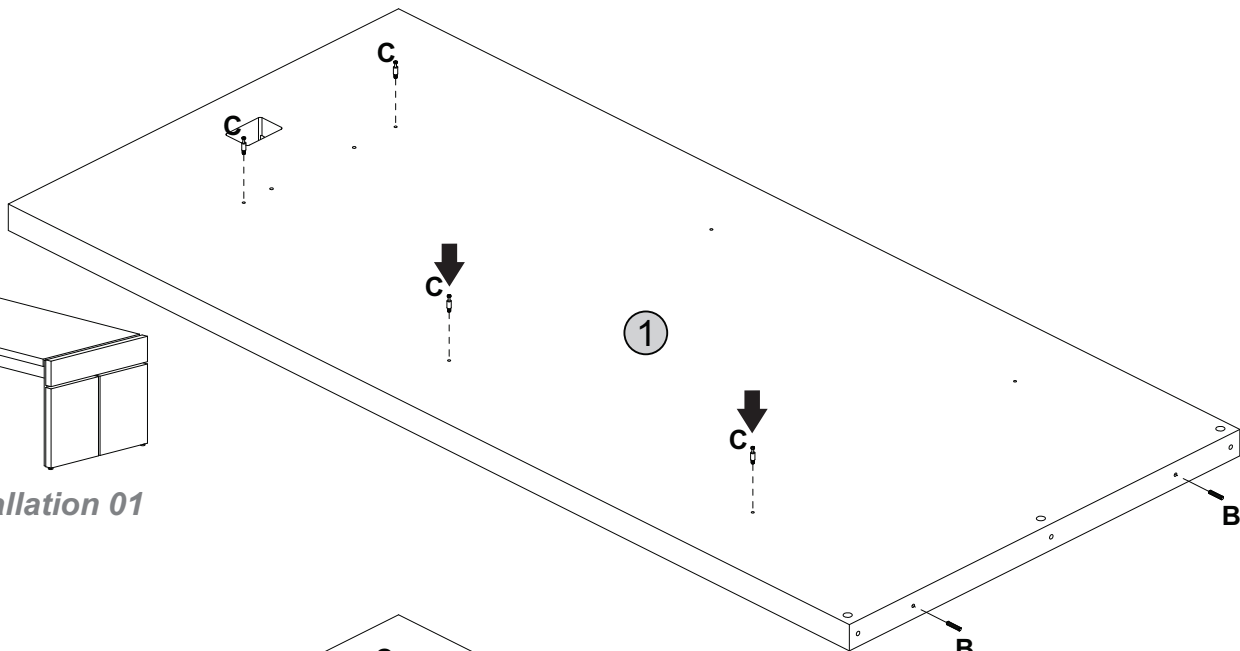

Montagem 02
Montaje 02 / Installation 02

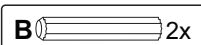
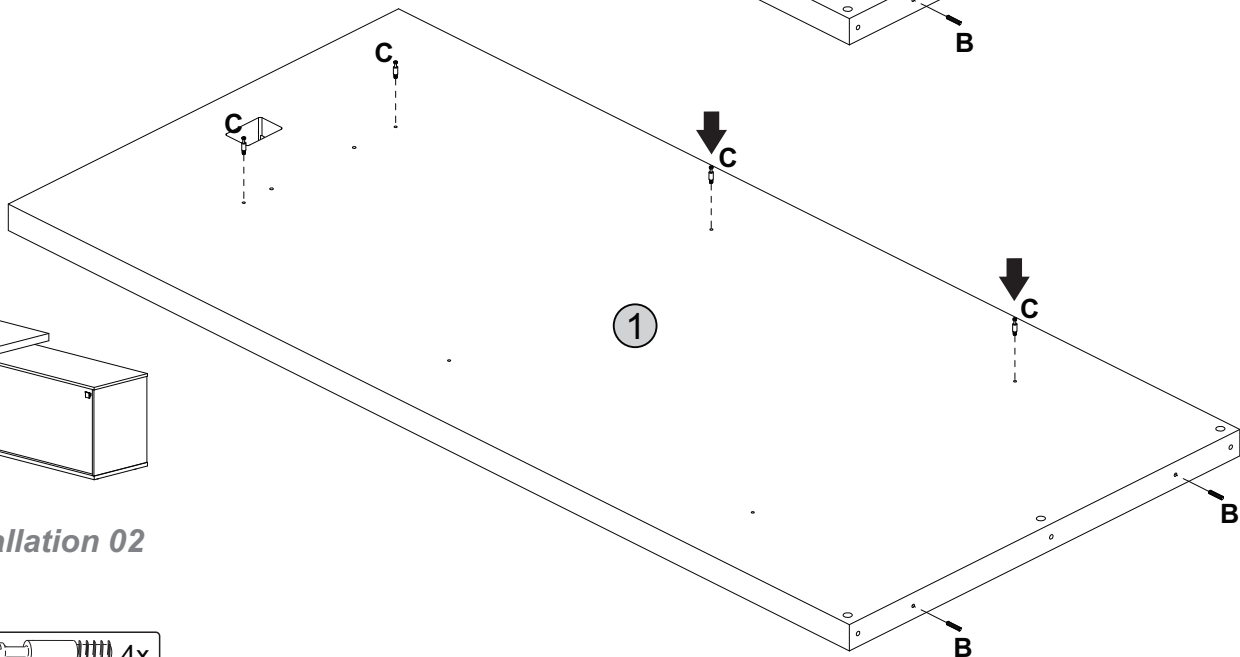
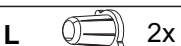
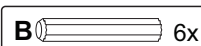
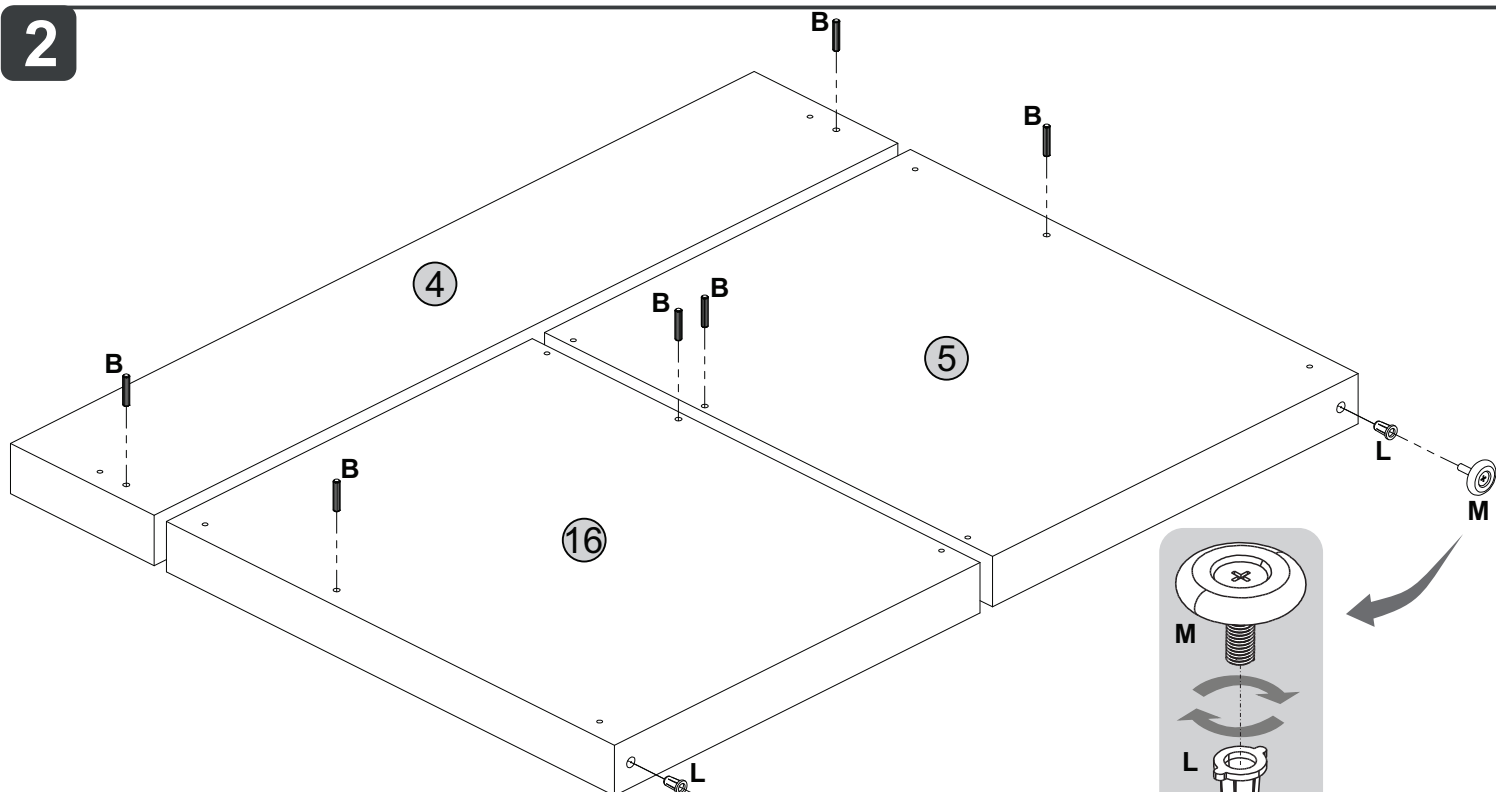
**2**

3

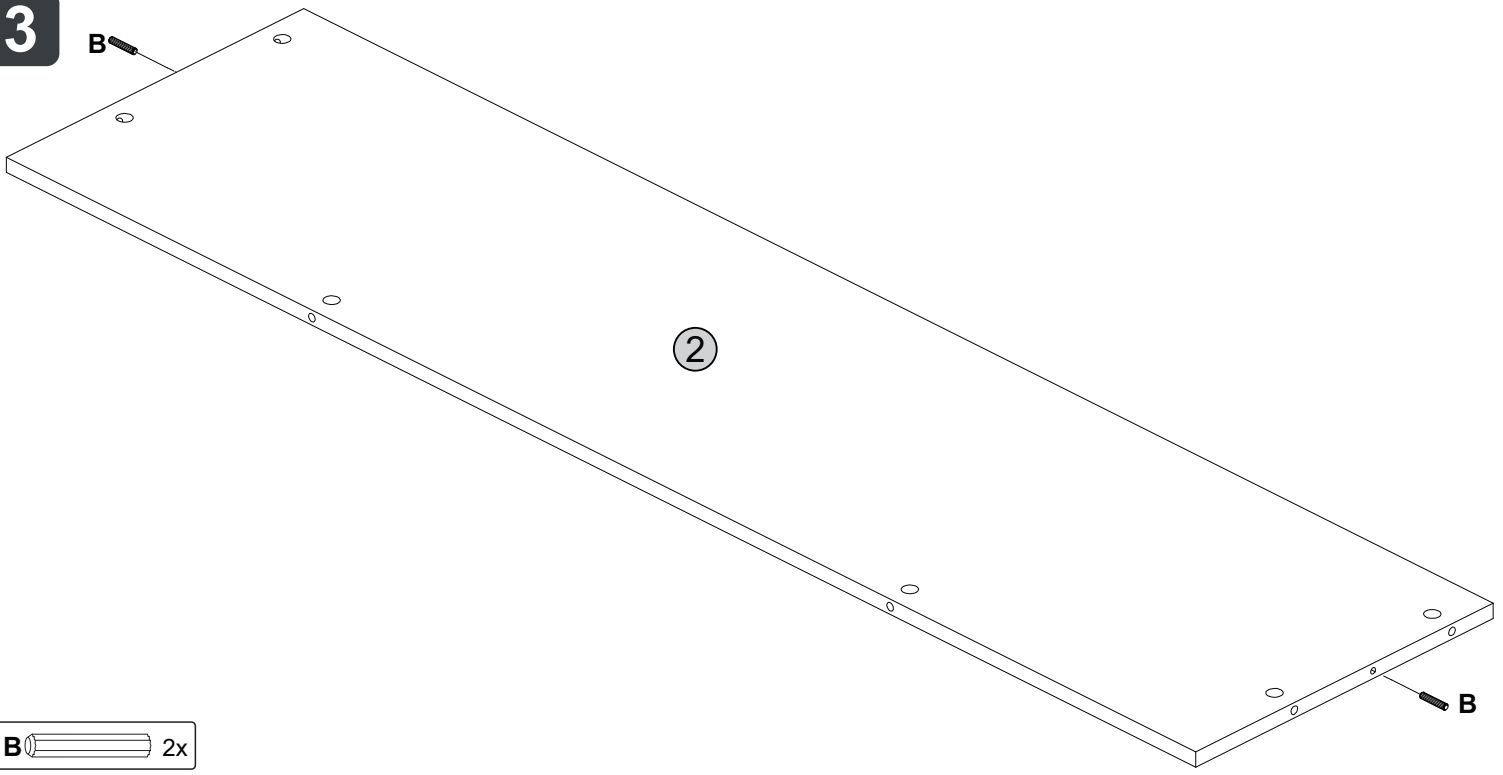

4

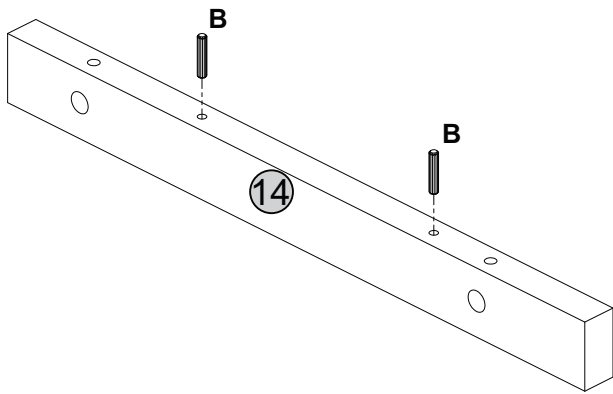

5

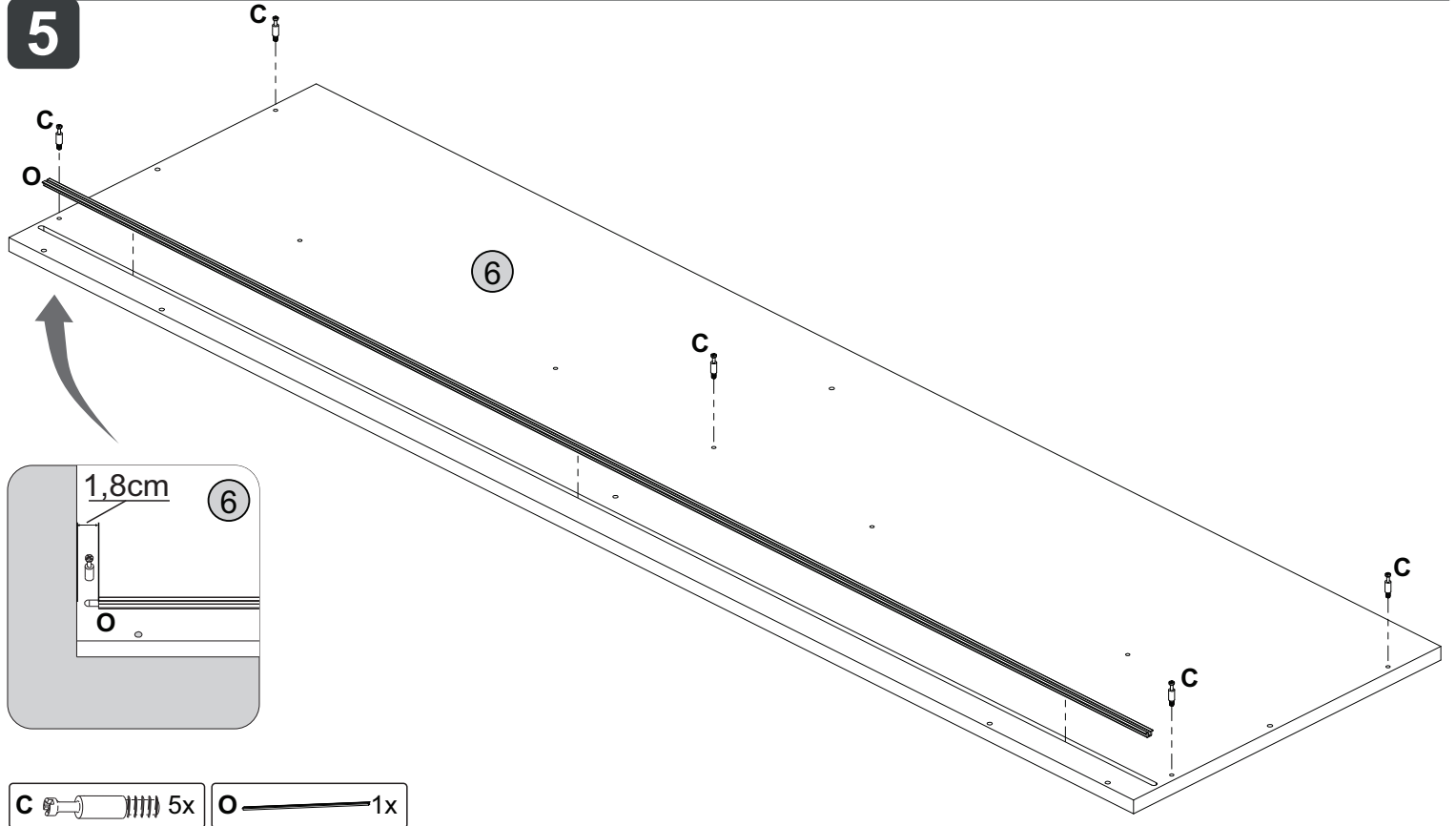



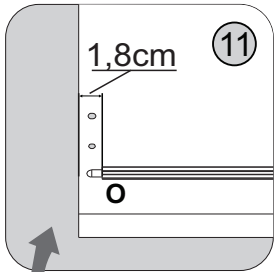
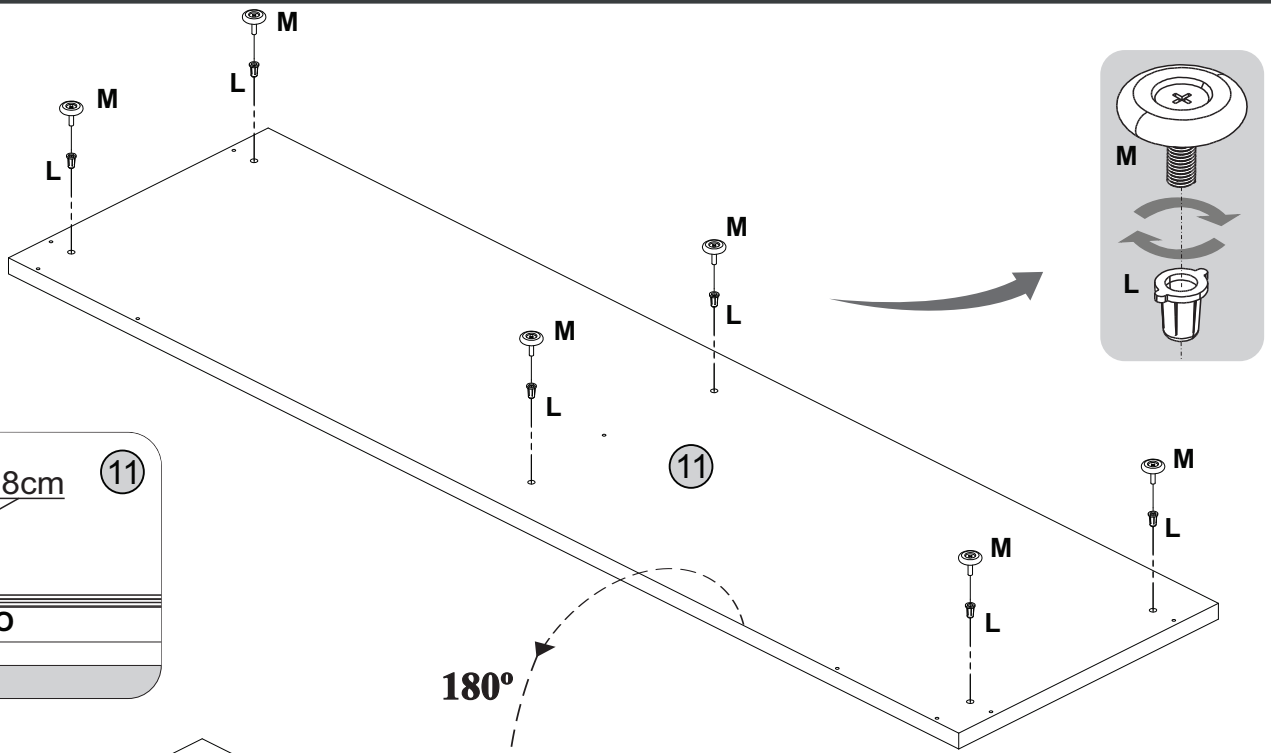

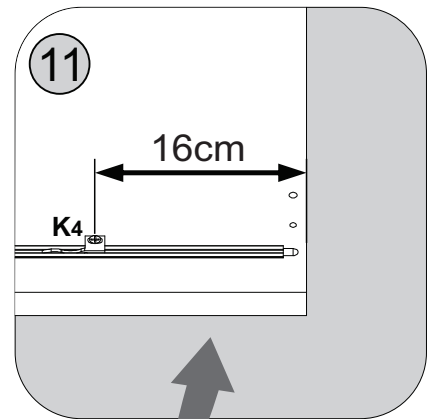
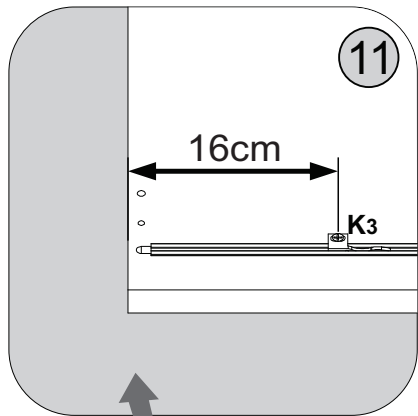

6



! Vire com cuidado.
Gire con cuidado.
Turn carefully.



- | | | | | | |
|----|----------------------------------------------------------------------------------------|----|----------------------------------------------------------------------------------------|---|----------------------------------------------------------------------------------------|
| L |  6x | M |  6x | O |  1x |
| K3 |  1x | K4 |  1x | J |  2x |

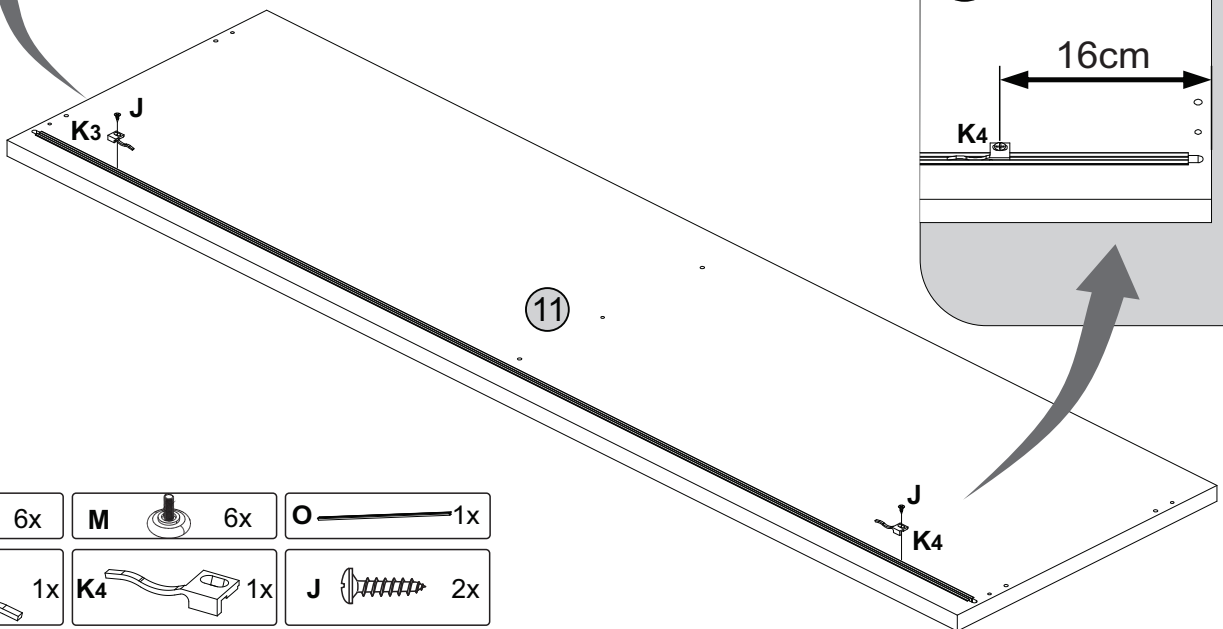

7

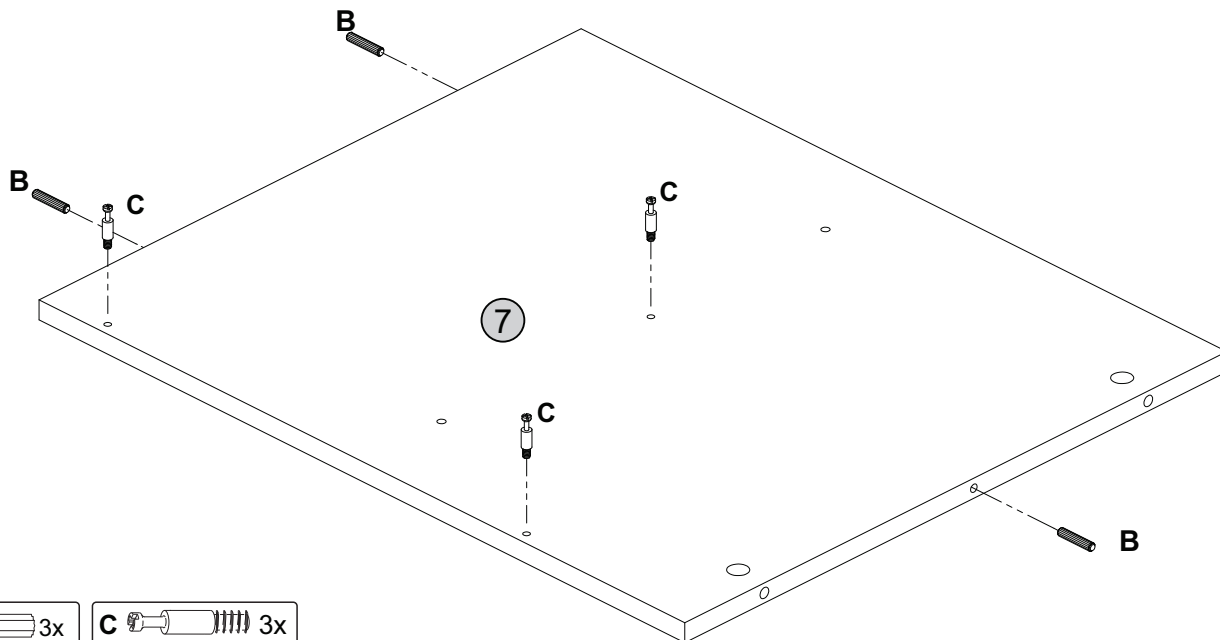

8

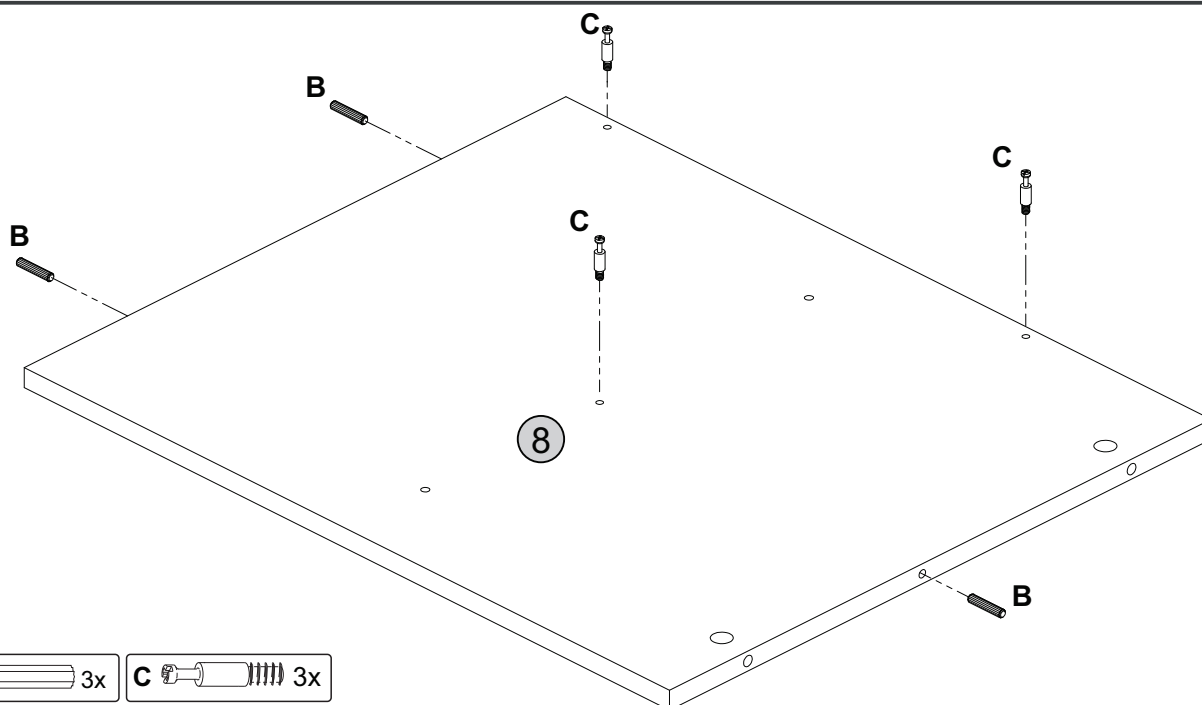

9

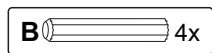
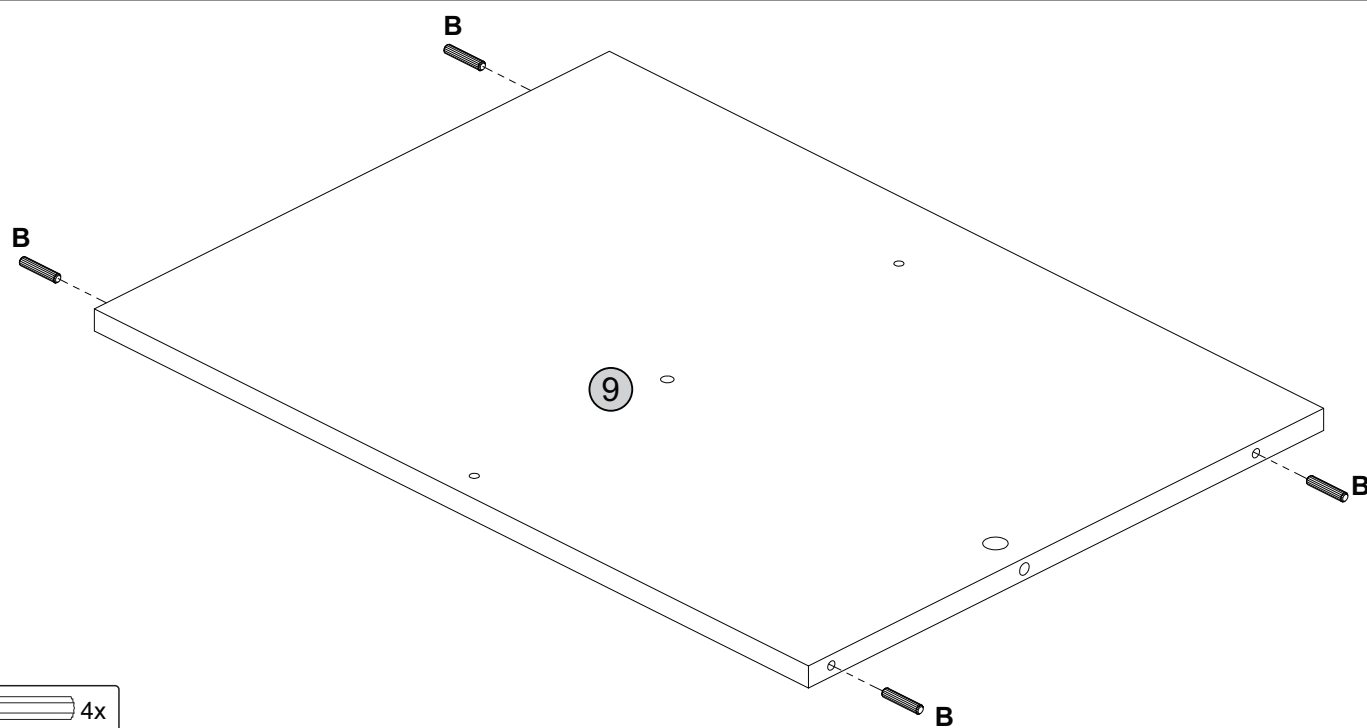

10

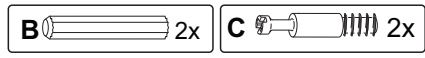
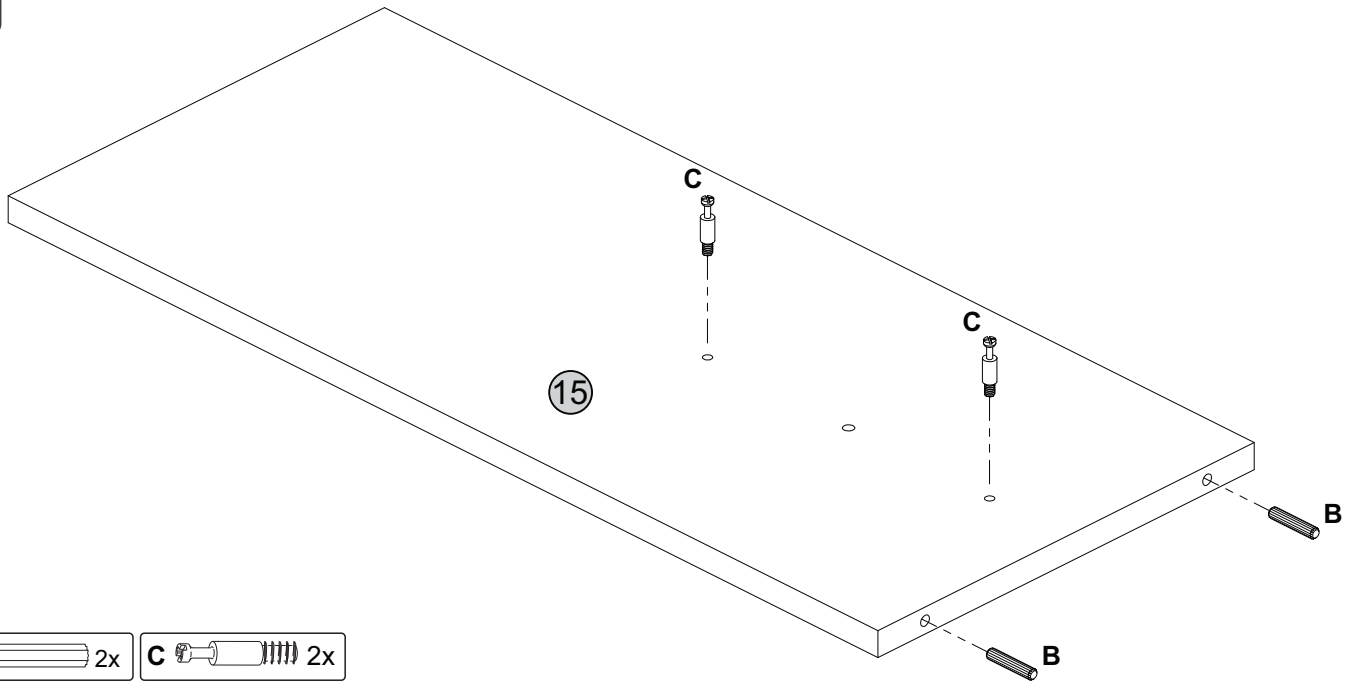

11

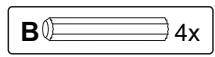
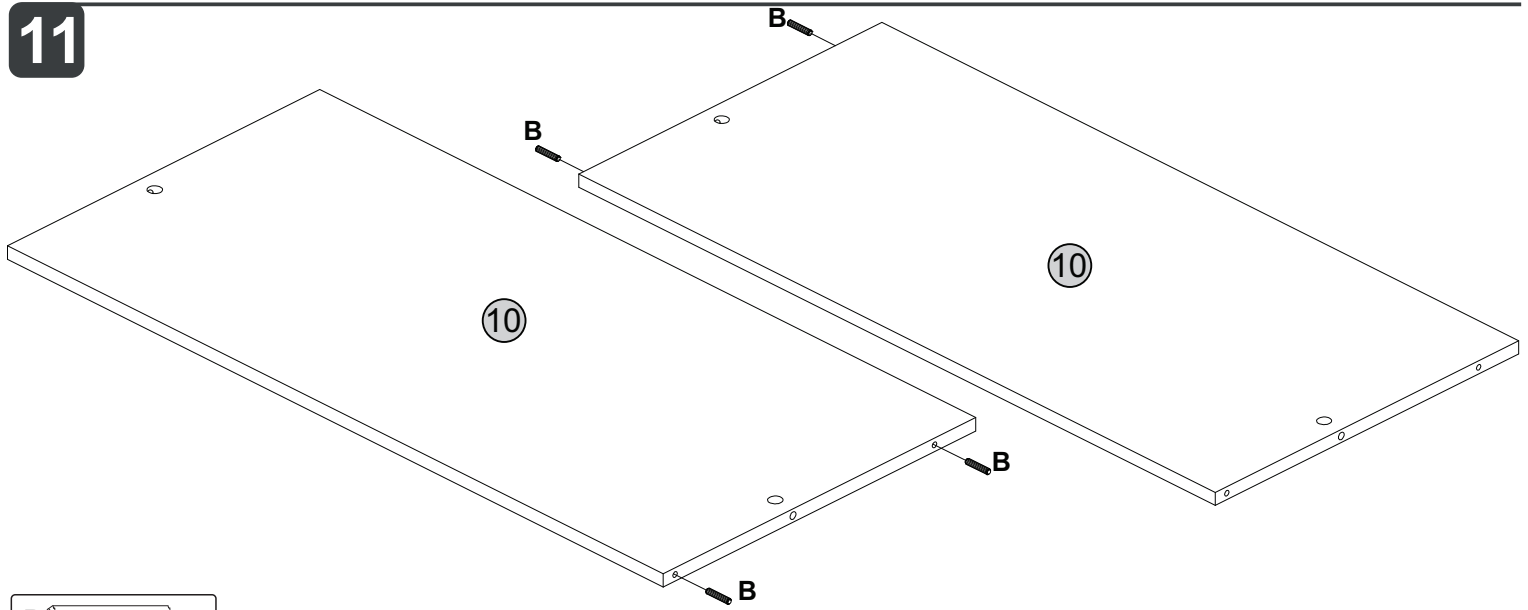

12

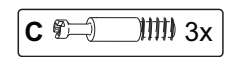
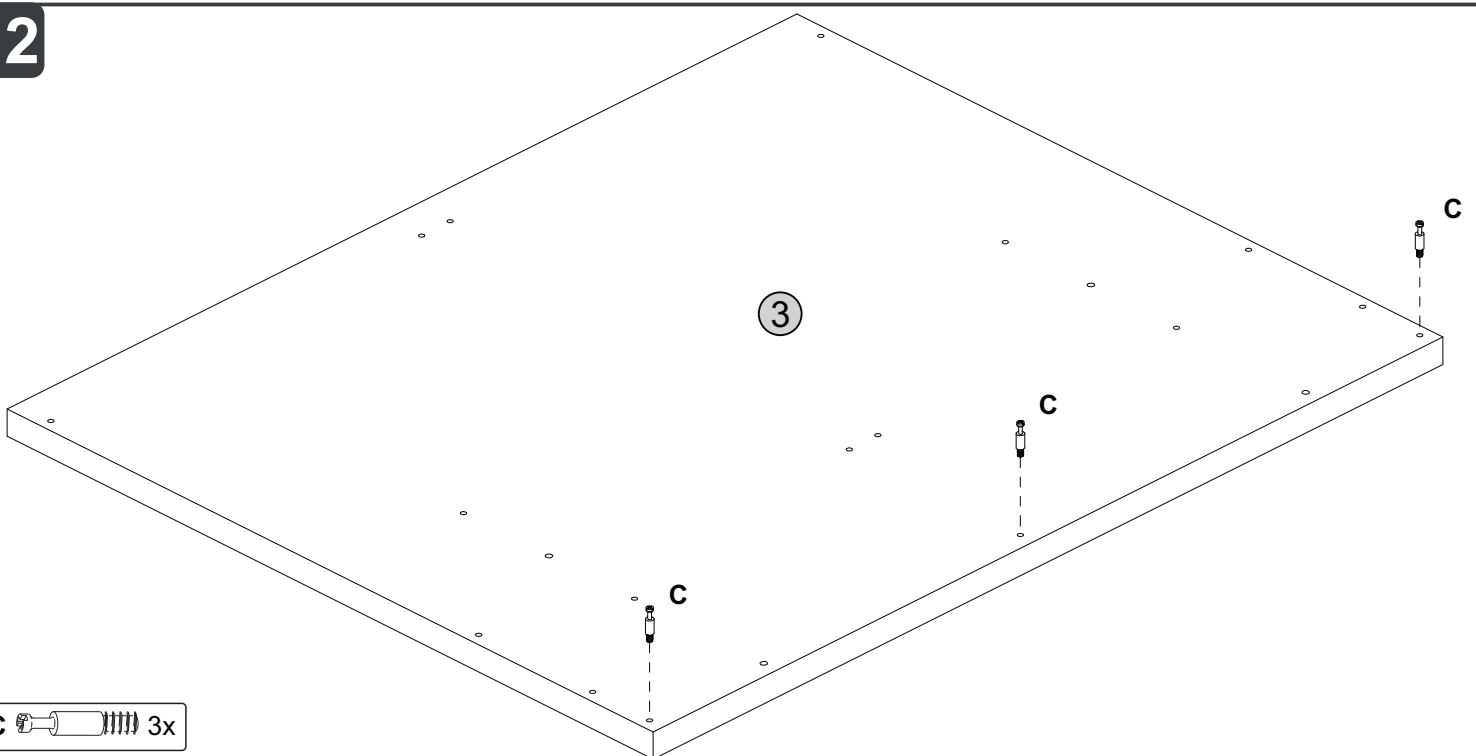

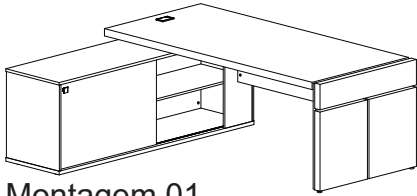

Montagem 01
 Montaje 01 / Installation 01

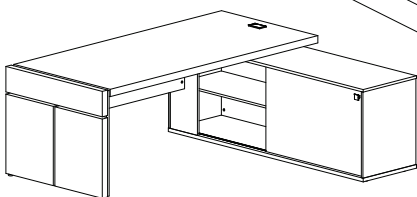
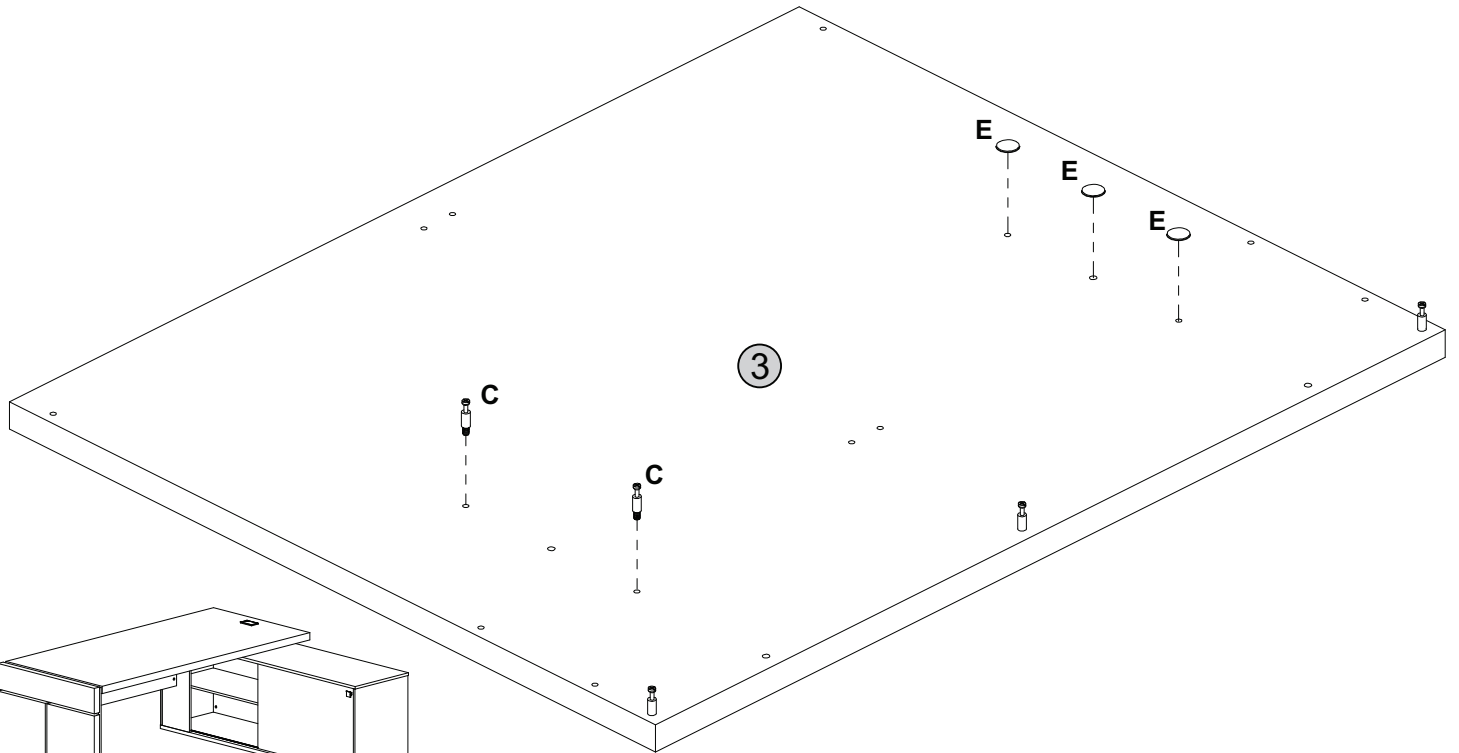
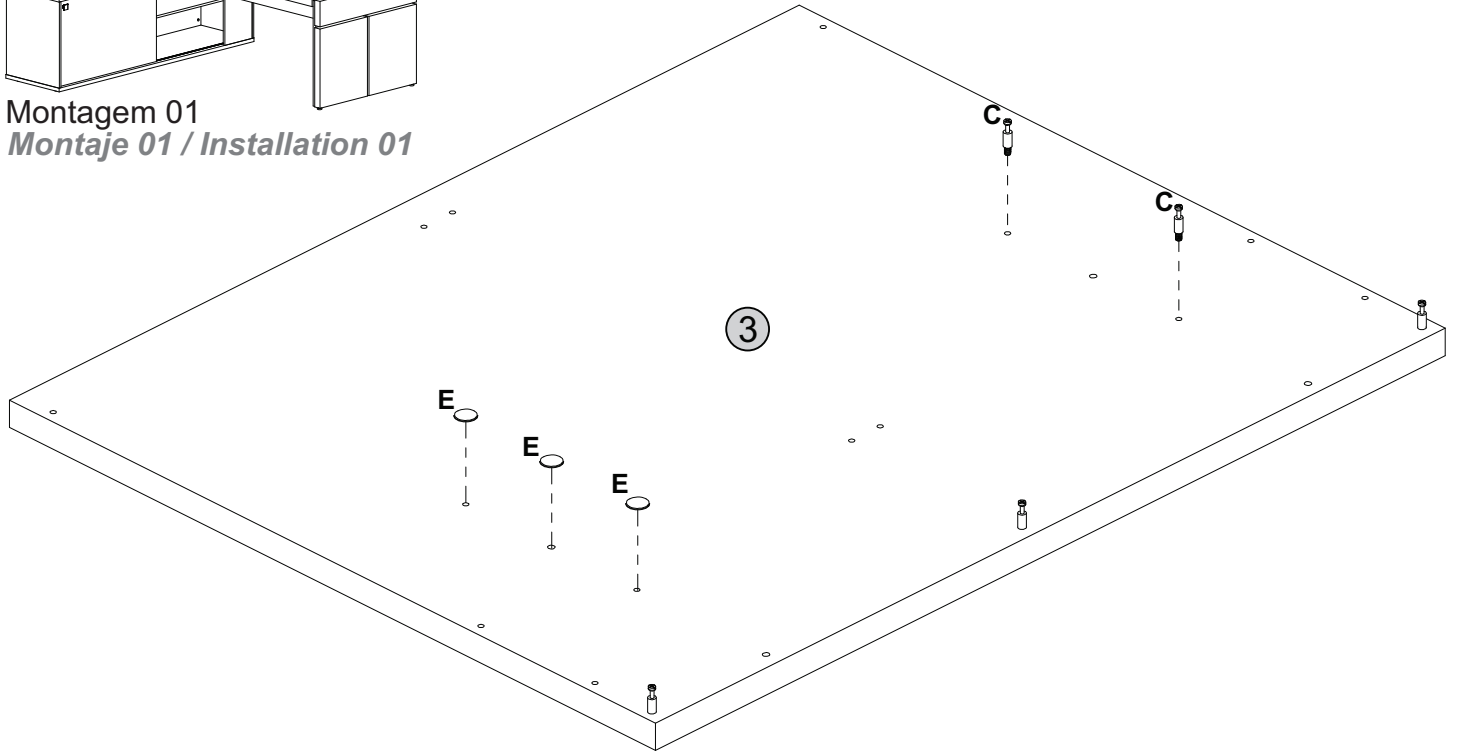

Montagem 02
 Montaje 02 / Installation 02



14

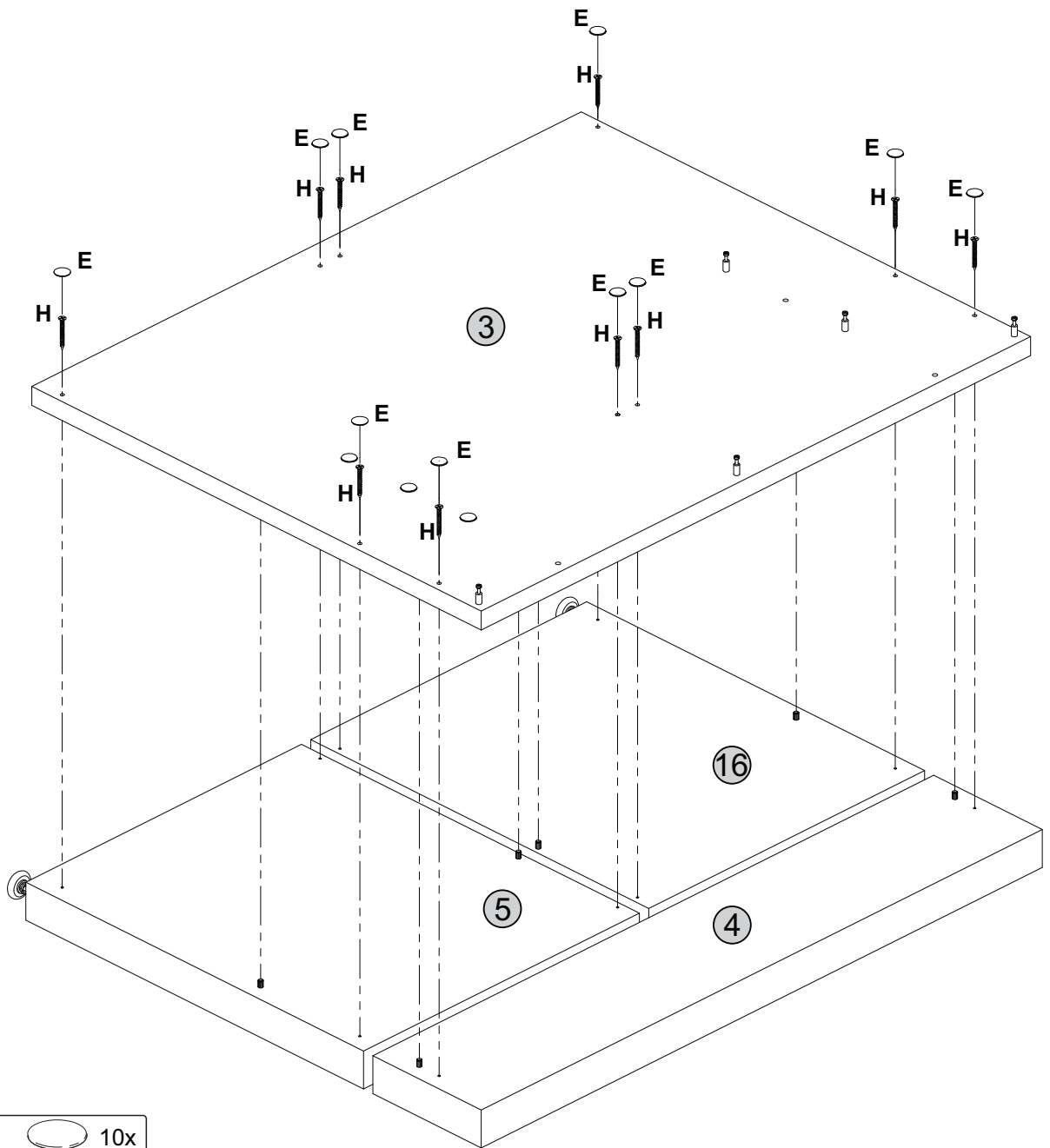
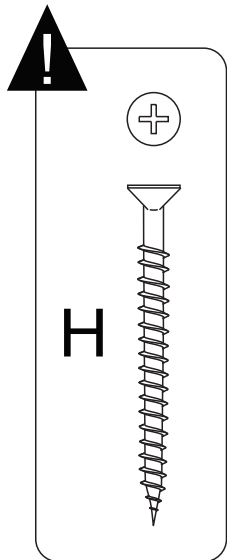

15

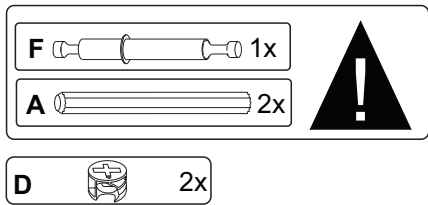
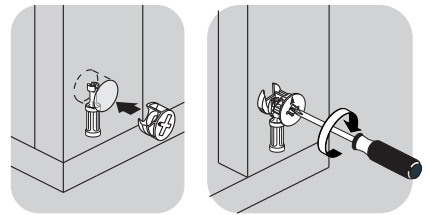
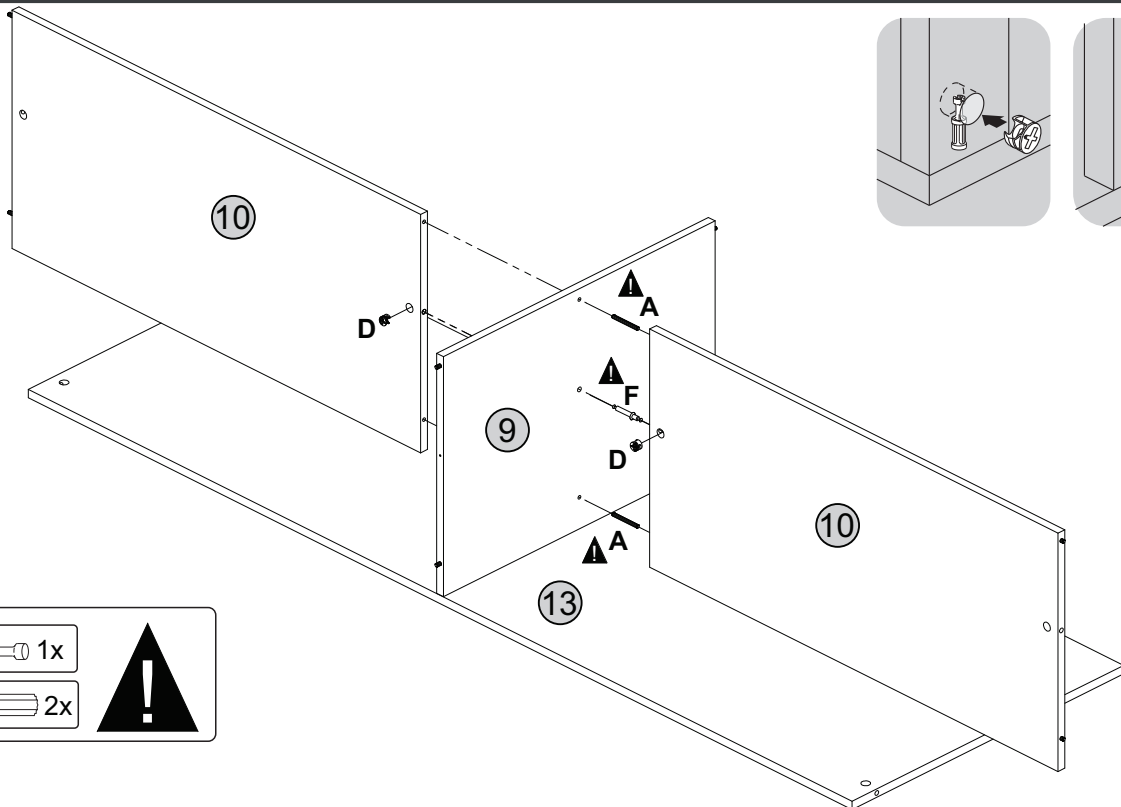

16

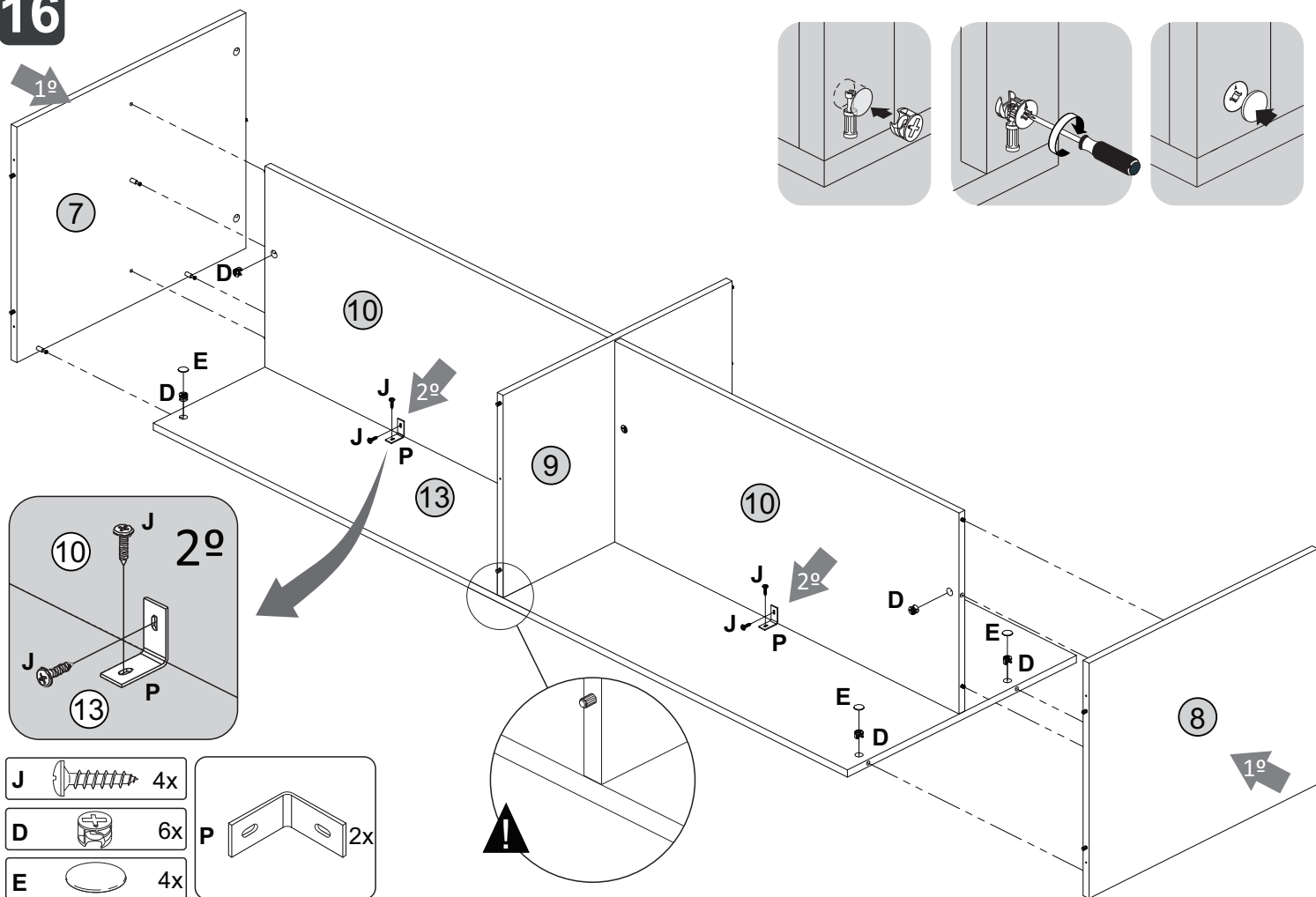

17

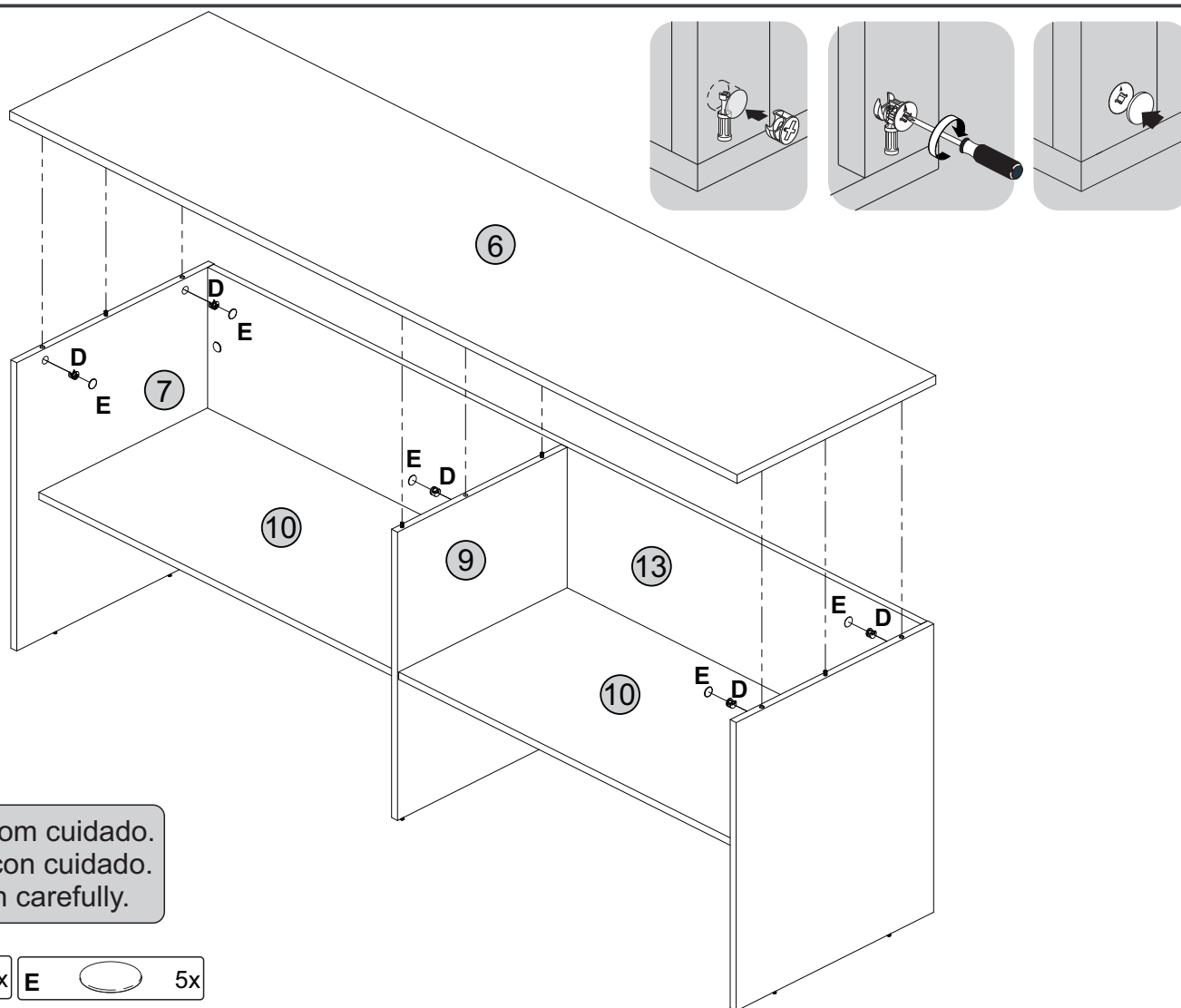

Vire com cuidado.
Gire con cuidado.
Turn carefully.

D  5x E  5x

! Vire com cuidado.
Gire con cuidado.
Turn carefully.

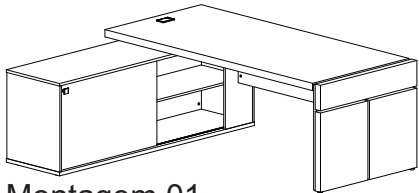

Montagem 01
Montaje 01 / Installation 01

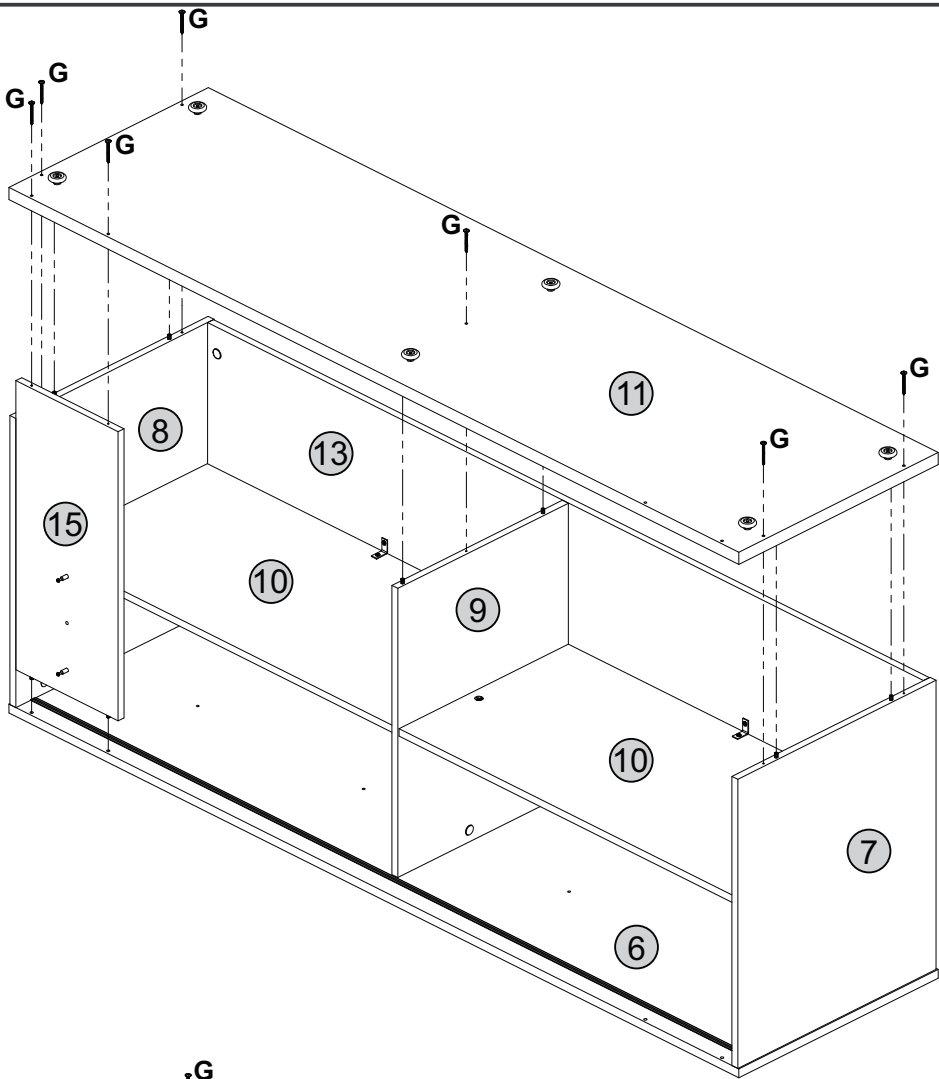

! Vire com cuidado.
Gire con cuidado.
Turn carefully.

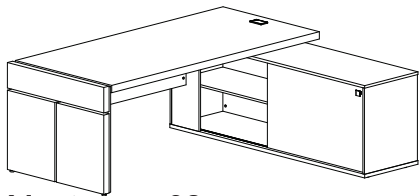

Montagem 02
Montaje 02 / Installation 02

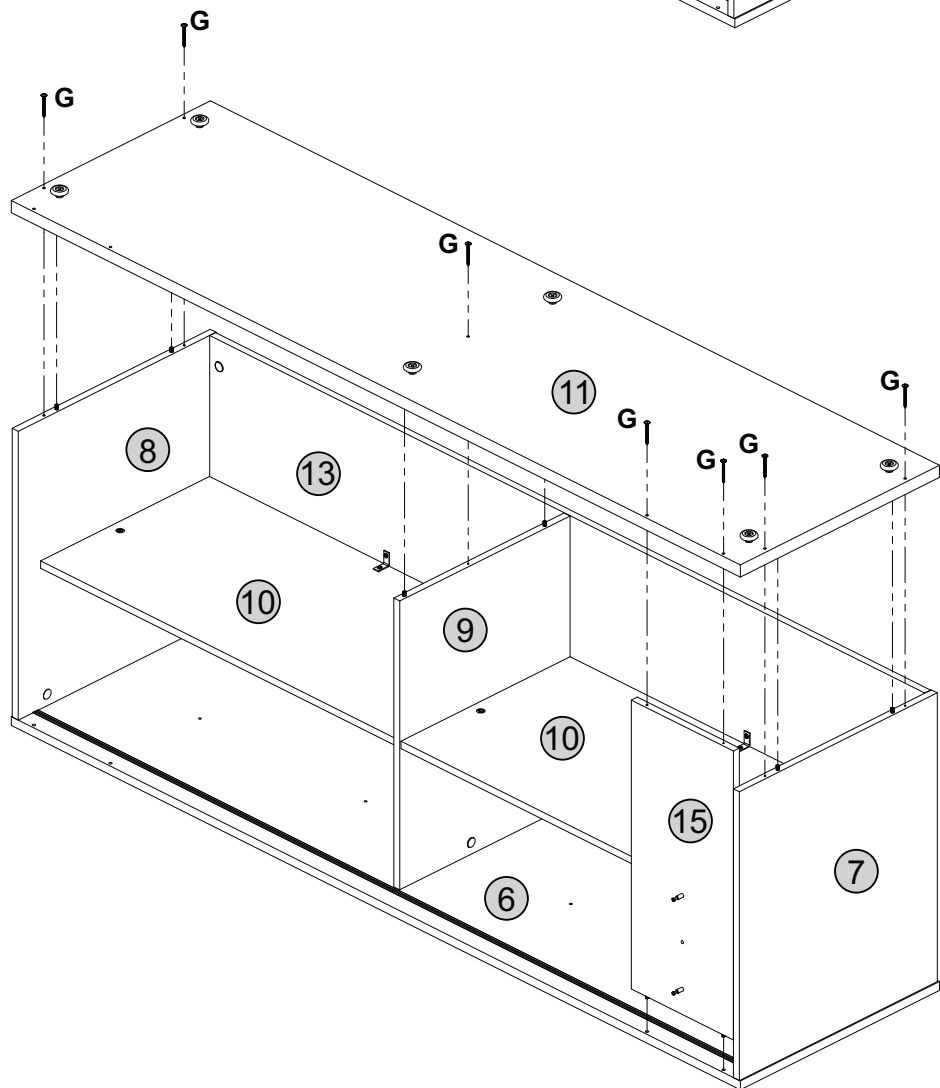

19

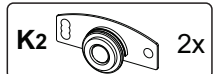
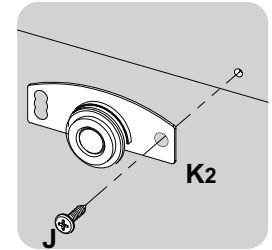
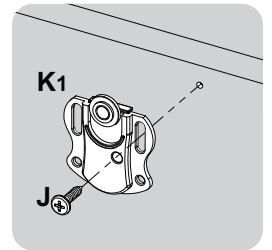
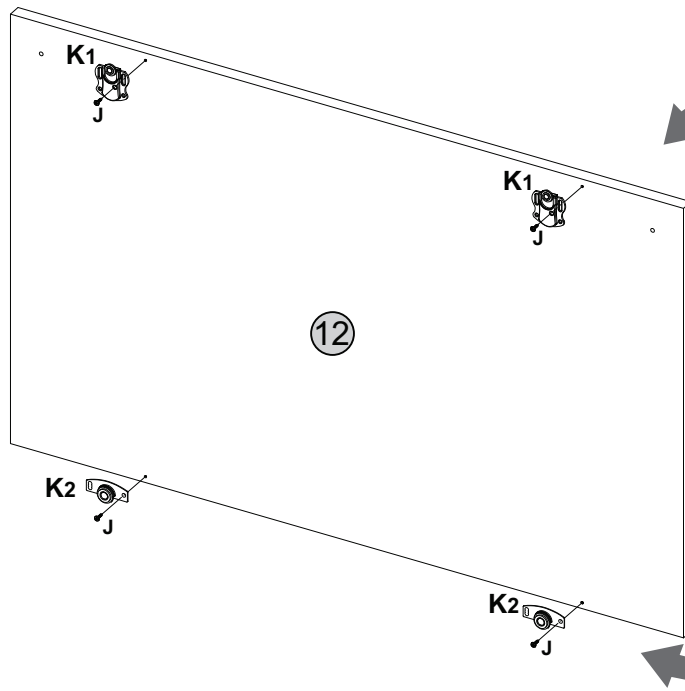

20

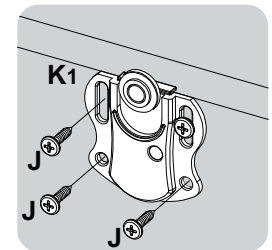
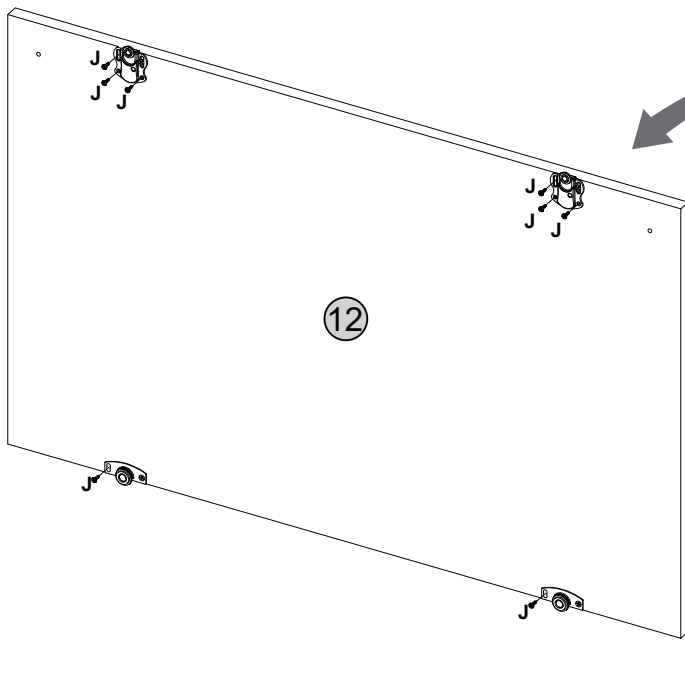

Regular altura da porta através dos oblongos.

Regular la altura de la puerta a través dos oblongos.

Adjust the height of the door using the oblongs.



21

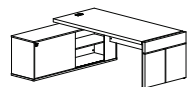

Montagem 01
Montaje 01 / Installation 01

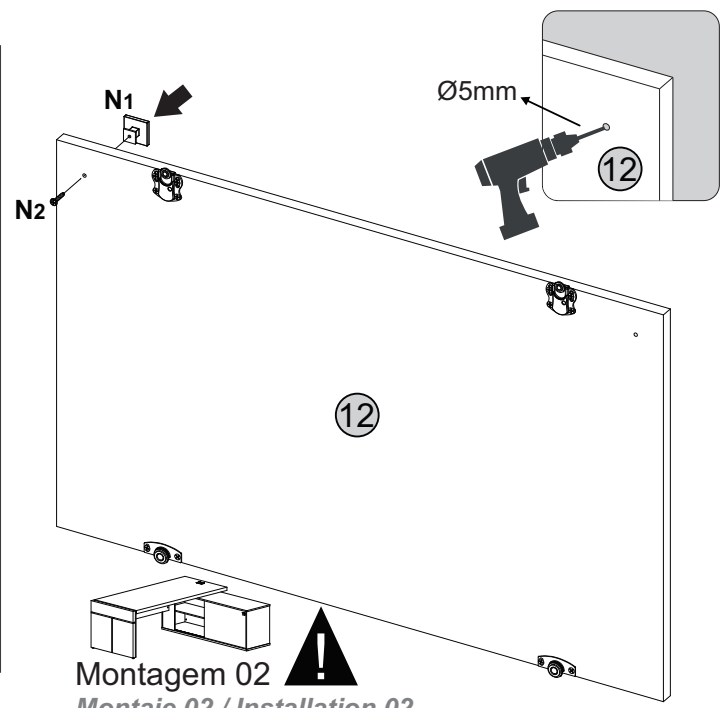
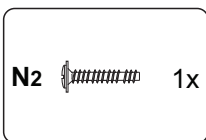
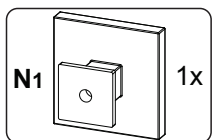
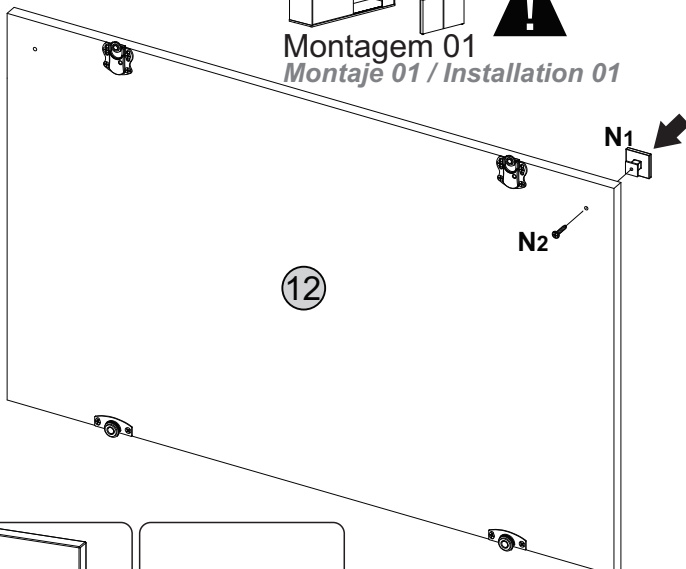

Montagem 02
Montaje 02 / Installation 02

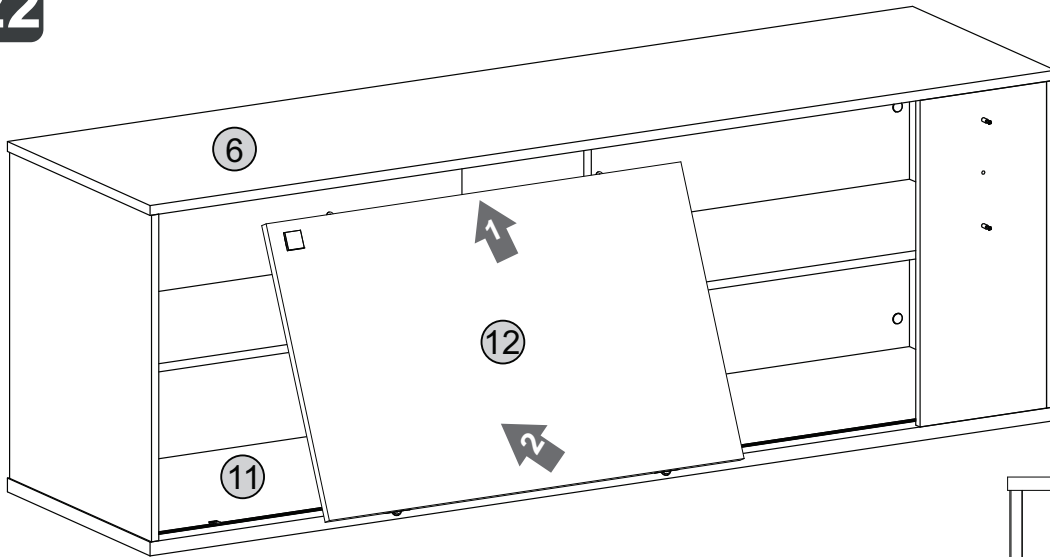

22

Regular altura da porta através dos oblongos.

Regular la altura de la puerta a través dos oblongos.

Adjust the height of the door using the oblongs.

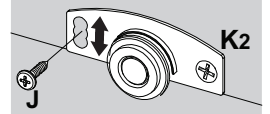

Caso necessário, regule as sapatas para nivelar o piso.

Si es necesario, ajuste las patas para nivelar el piso.

If necessary, adjust the feet to level the floor.

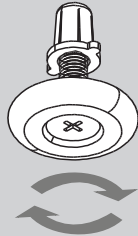

Lateral
Lado
Side

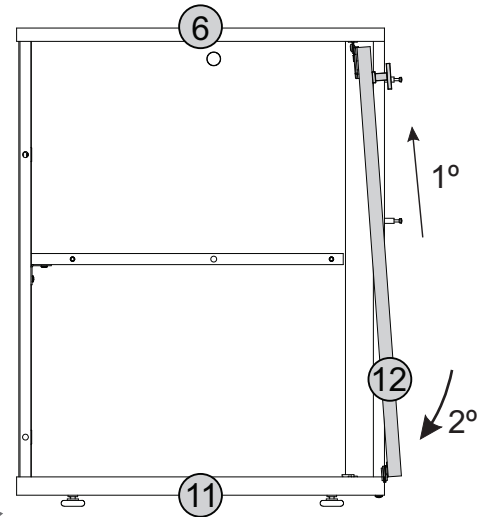
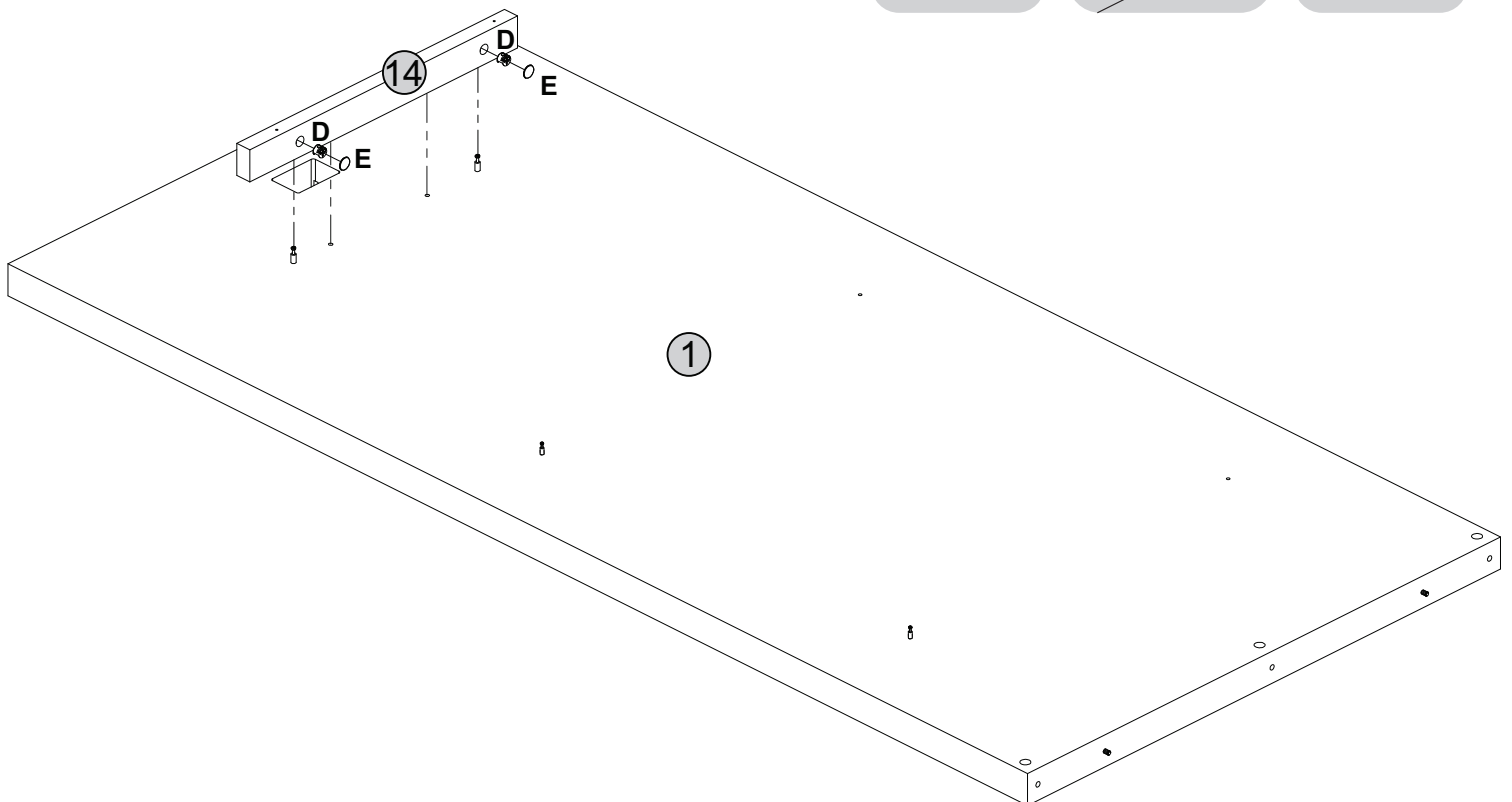
**23**

D  2x **E**  2x

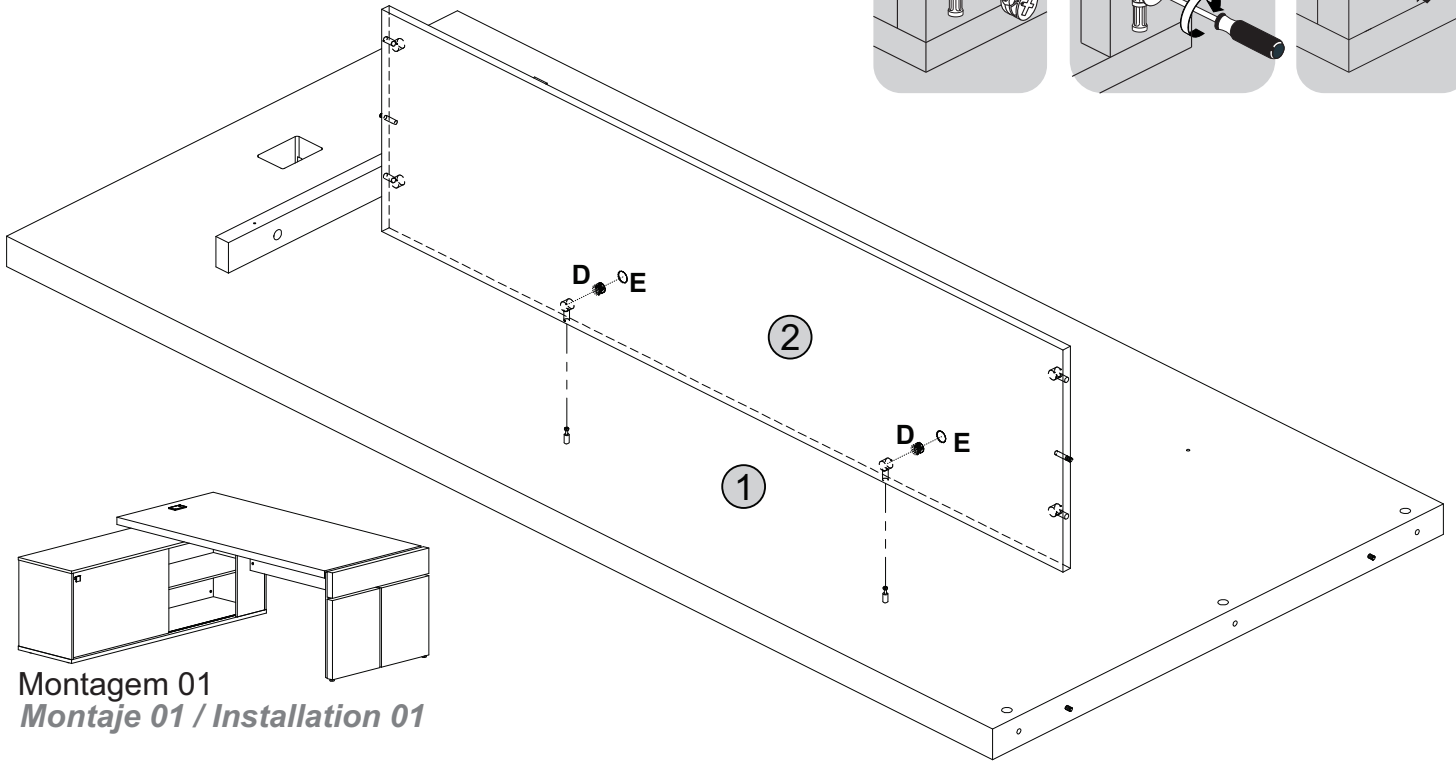
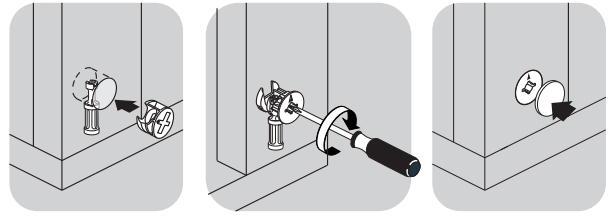

Montagem 01
 Montaje 01 / Installation 01

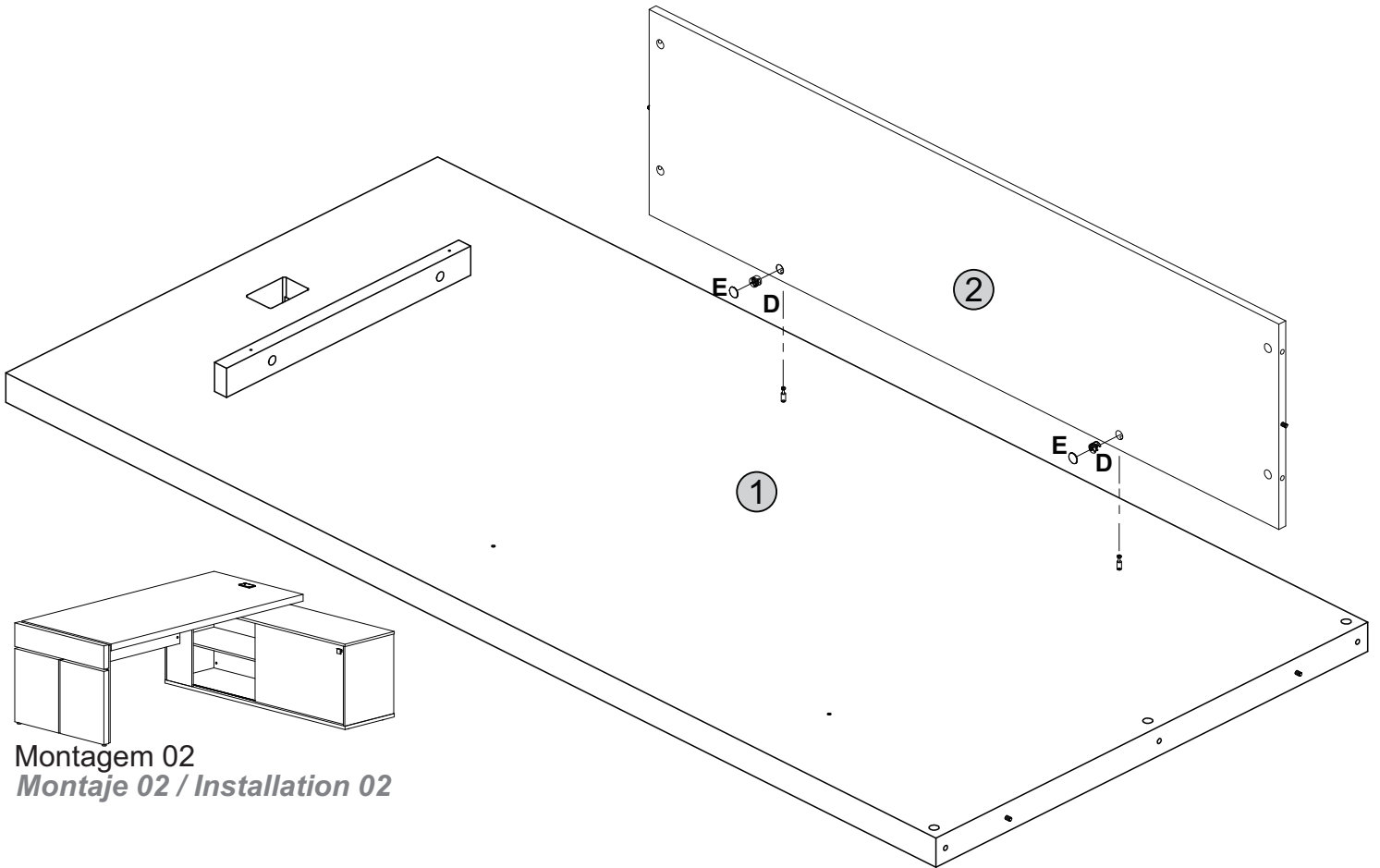

Montagem 02
 Montaje 02 / Installation 02



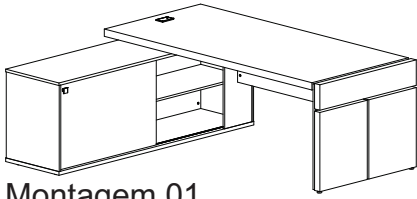
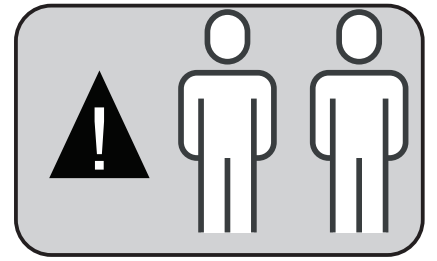

Montagem 01
Montaje 01 / Installation 01

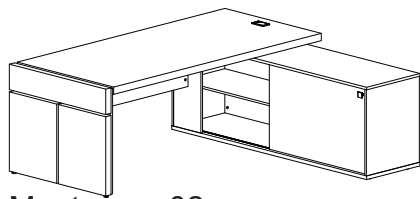
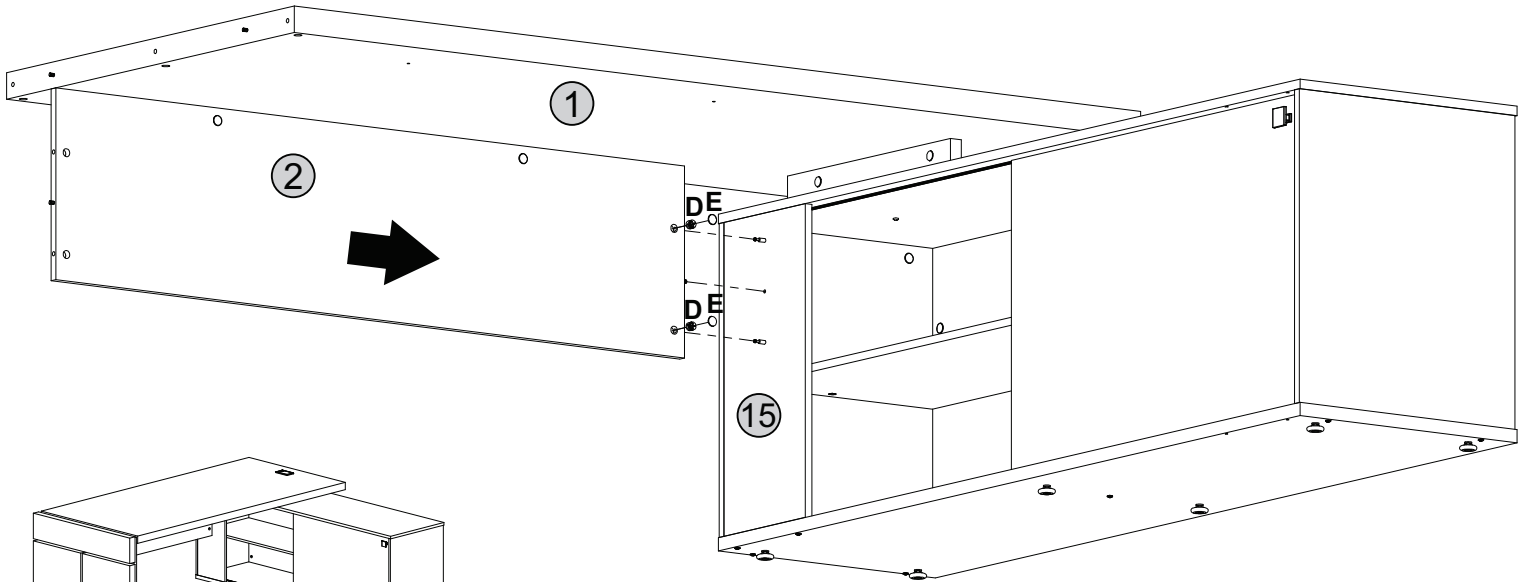
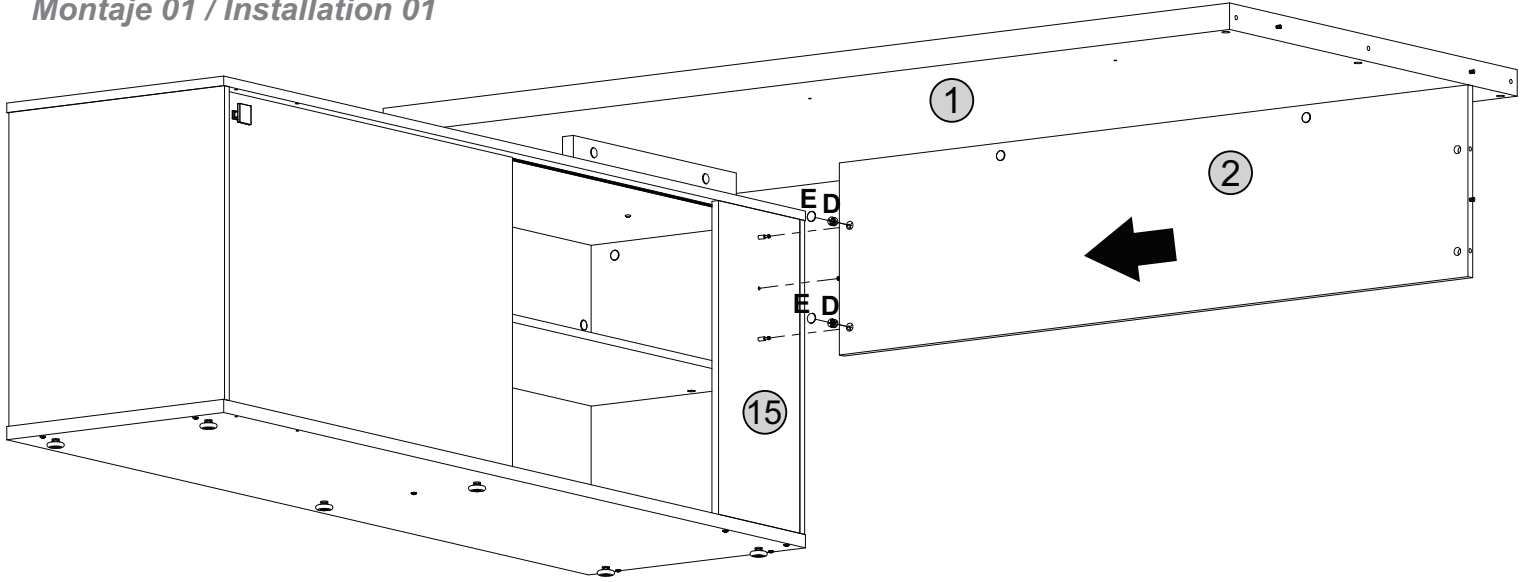

Montagem 02
Montaje 02 / Installation 02

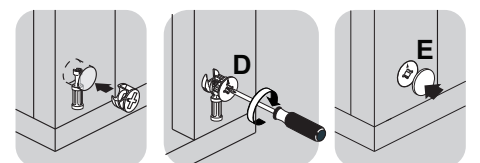

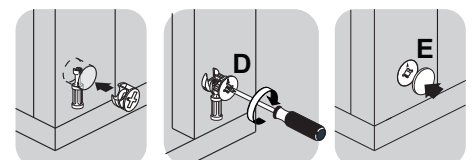
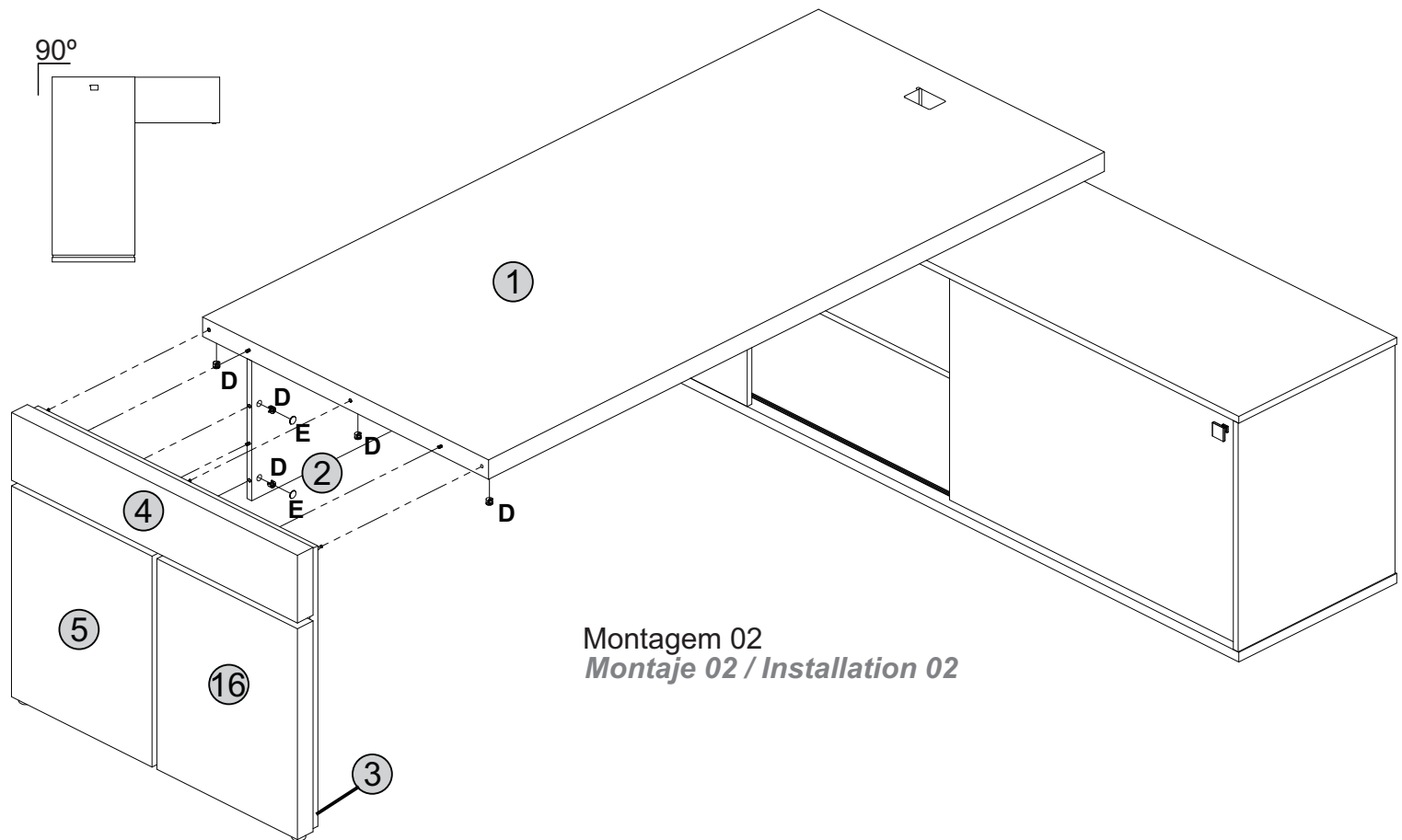
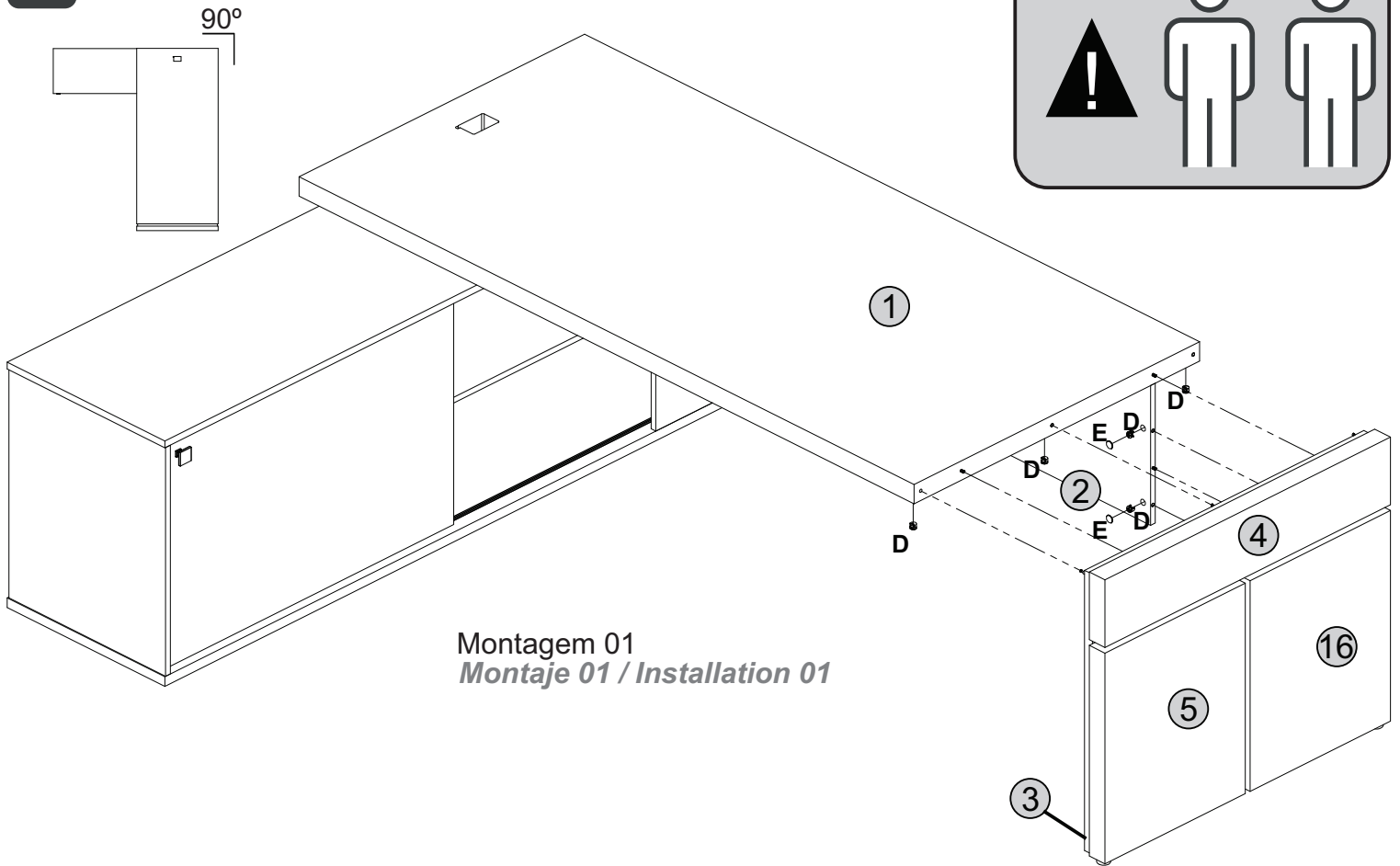
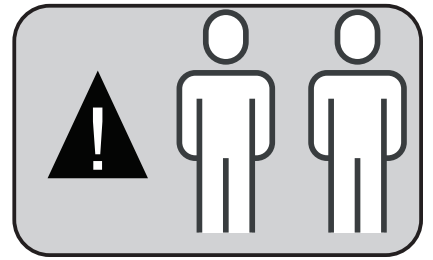

- D  5x
- E  2x

27

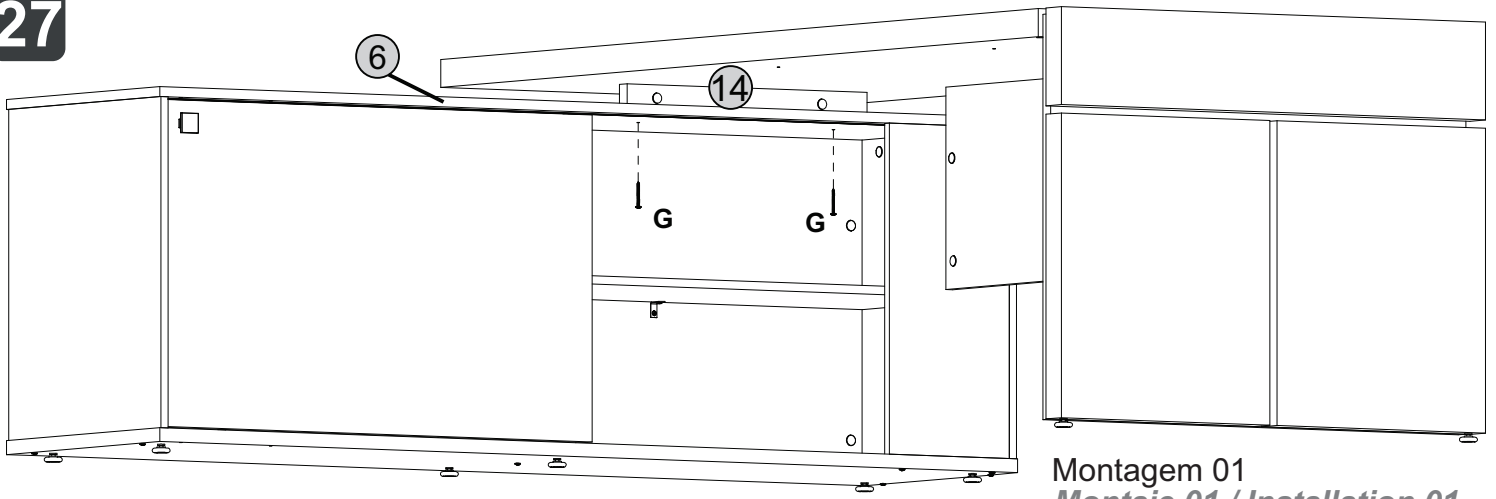

Montagem 01
Montaje 01 / Installation 01

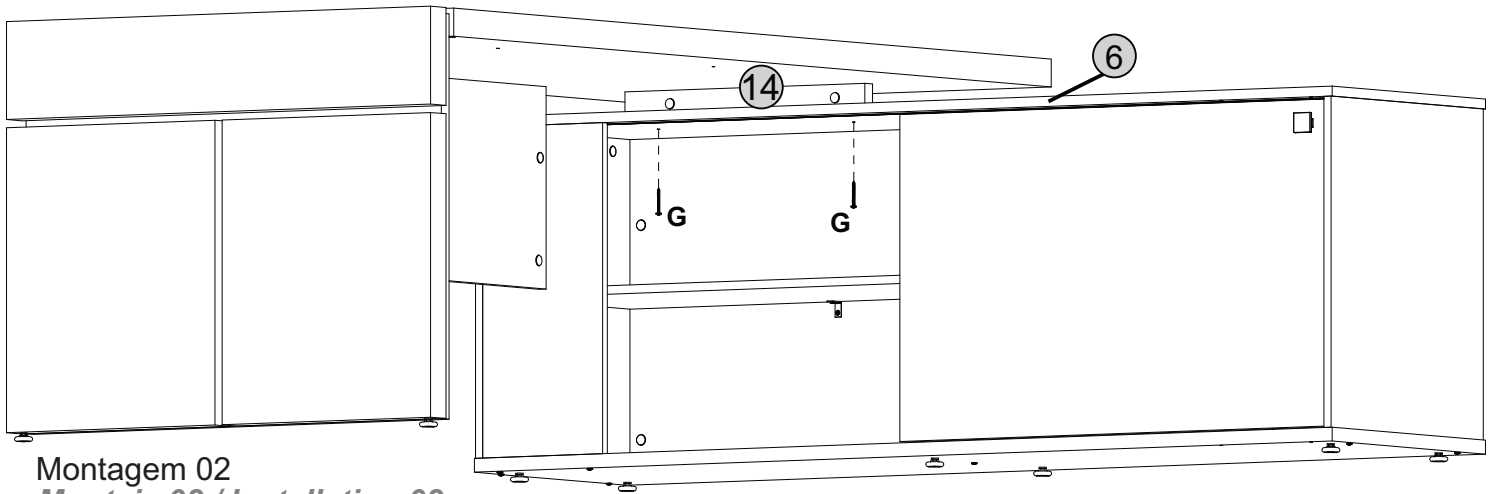



Montagem 02
Montaje 02 / Installation 02

G  2x

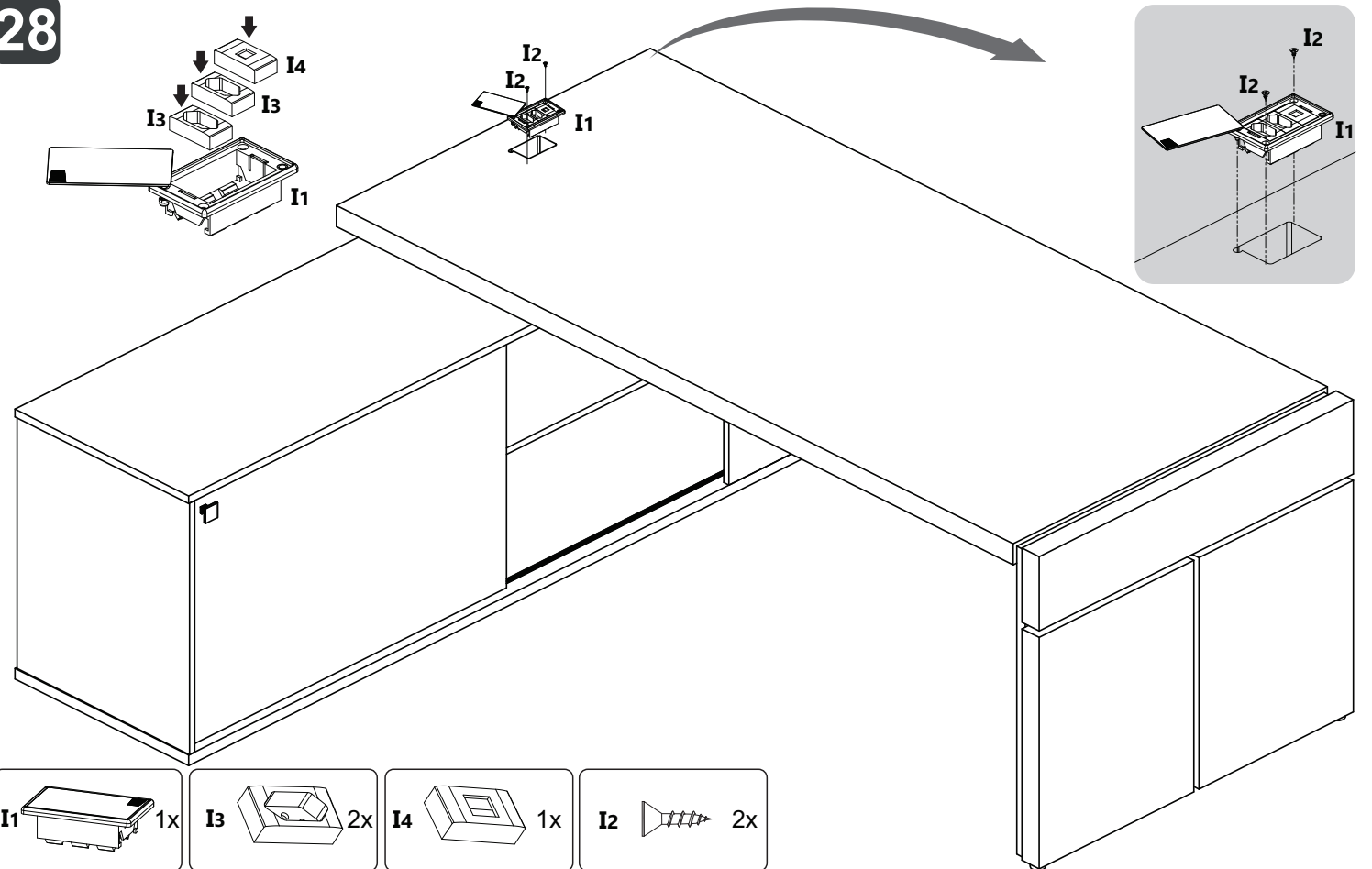
28

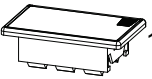
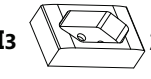
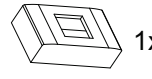

- 
1x
- 
2x
- 
1x
- 
2x

Obrigado

POR SUA CONFIANÇA EM NOSSO TRABALHO!



Esperamos que sua experiência de compra, montagem e instalação tenha sido perfeita!

Desejamos que seu móvel possa tornar seu Home Office, casa ou escritório, um ambiente muito mais agradável e organizado, fazendo seu trabalho, estudo ou descanso ser muito mais proveitoso!

APROVEITE SEU MÓVEL ARTANY!

Se tiver alguma dúvida, sugestão ou comentário, pode entrar em contato no nosso WhatsApp (41) 99684-9543, telefone (41)3556-1550, ou email artany@artany.com.br



Gostou? Compartilhe este momento e marque a gente!



@artanymoveis



ARTANY[®]
Arte em Home Office