

kappesberg

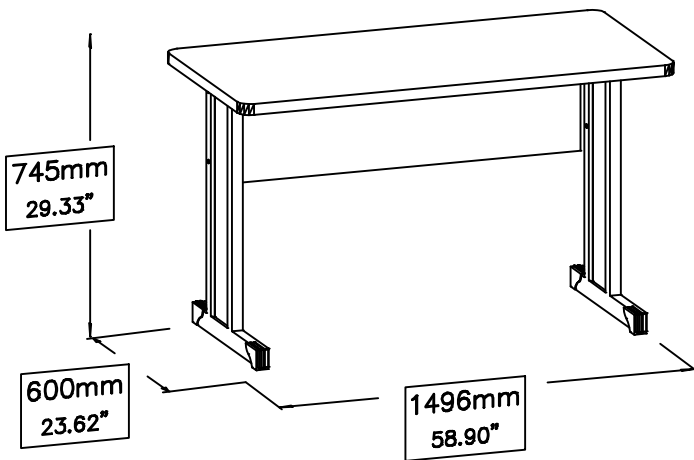

A montagem deve ser efetuada por UMA pessoa.
El montaje debe ser efectuado por UNA persona.
The assembly must be done by ONE people.

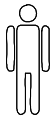

Ferramentas necessárias para montar o móvel
Herramientas necesarias para armar el mueble.
Tools needed to assemble the furniture.

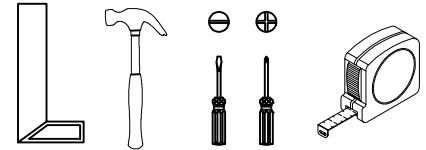

Montar o móvel sobre uma superfície limpa e plana
Armar el mueble sobre una superficie limpia y plana
Assemble the furniture on a clean and flat surface

S:\Pastas pessoais\Rudimar\Capturar 2.PNG

IDENTIFICAÇÃO DAS PEÇAS/ IDENTIFICACIÓN DE LAS PIEZAS/ PARTS IDENTIFICATION

Lista de peças / Lista de piezas / List of pieces

Código / Code	Descrição	Descripción	Description	Quantidade / Cantidad / Amount	Comprimento / Longitud / Length (mm)	Comprimento / Longitud / Length (in.)	Largura / Ancho / Width (mm)	Largura / Ancho / Width (in.)	Espessura / Espesor / Thickness (mm)	Espessura / Espesor / Thickness (in.)	Caixa / Caja / Box
2057	Tampo	Panel superior	Top bottom panel	1	1496	58.90"	600	23.62"	30	1.18"	A
2058	Reforço	Reforzamiento	Strengthening	1	1264	49.76"	344	13.54"	15	.59"	A
2059	Laterais	Lados	Sides	2	675	26.57"	128	5.04"	15	.59"	A

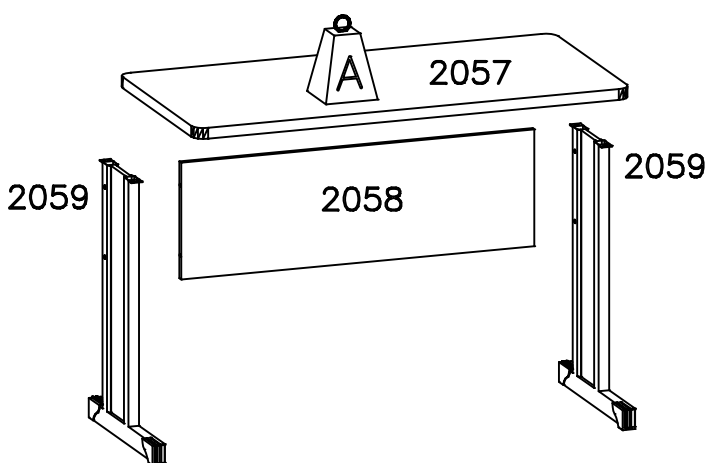
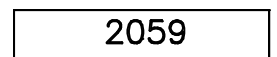
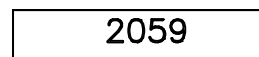
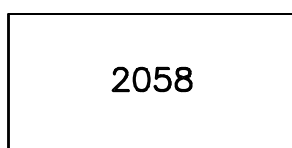
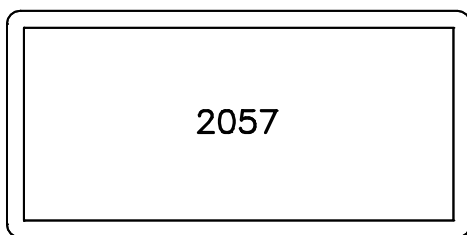

Duvidas? entrar em contato:
¿Dudas? Ponerse en contacto:
Doubts? Get in touch:

Fone: (51) 3635-8839
www.kappesberg.com.br

	Kg	lb
A	30	33.07lb

1150







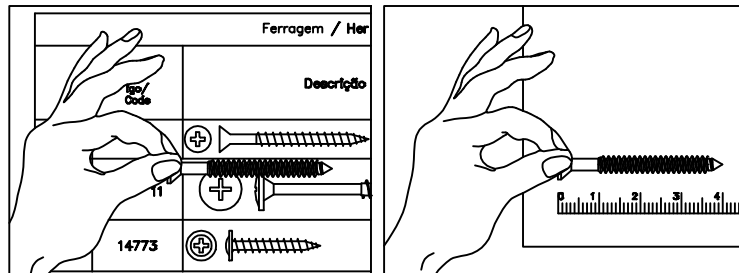

IDENTIFICAÇÃO DOS ACESSÓRIOS/ IDENTIFICACIÓN DE ACCESORIOS/ IDENTIFICATION OF ACCESSORIES

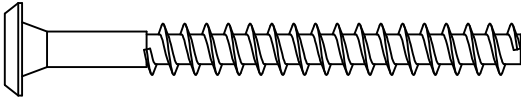
–NOTAS: A separação dos acessórios antes de iniciar a montagem facilitará a mesma. Os parafusos e cavilhas estão na escala real. Em caso de dúvida na identificação, coloque o acessório sobre a imagem.

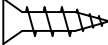
–NOTAS:La separación de los accesorios antes de comenzar el armado facilitará el mismo. Los tornillos y taquetes son en escala real. En caso de dudas sobre la identificación, coloque el accesorio en la imagen.

–NOTES:The separation of the accessories before you start the assembly will facilitate the same. The screws and dowels are in real scale. In case of doubts about the identification, place the accessory on the image

**Ferragem / Herrajes / Hardware**

	Código/ Código/ Code		Descrição / Descripción / Description	Quan./ Cant./ Amou.
PE12	1260		 Parafuso estrutural/ Tornillo estructural/Structural screw 7x70	4
PC3	4214		 Parafuso/ Tornillo/ Screw 3,5X14	16
C1	1802		Cavilha/Tarugo/Dowel 6x30mm	2
CZ1	248		Chave Allen/ Llave Allen/ Allen key 1/4"	1
CPL	TI=4430 (Cinza) IT=40671(Preto)		Tampa CPL/ Tapa CPL/ CPL cover 13mm	4
EM	58		Etiqueta marca/Tag label "Kappesberg"	1
CG	899		Cantoneira/Cantón / Angle bracket	2
PZ	TI=4374 IT=59615		Pé da mesa/Pie de mesa/Table foot (Par)	1

Prezado Montador:

– Antes de iniciar a montagem verifique as condições do ambiente de montagem;
– Confira todas as peças das embalagens com a lista de peças contida neste manual;
– Separe os acessórios, confira as medidas dos parafusos com a escala;
– Siga todas as orientações deste manual de montagem para ter o direito à garantia do produto;
– Descarte as embalagens de forma correta, destinando o plástico e o papel para reciclagem;

Estimado Montador:

– Antes de iniciar a montagem verifique as condições do ambiente de montagem;
– Confira todas as peças das embalagens com a lista de peças contida neste manual;
– Separe os acessórios, confira as medidas dos parafusos com a escala;
– Siga todas las orientaciones deste manual de montagem para ter o direito à garantia do produto;
– Descarte como embalagens de forma correta, destinando o plástico e o papel para reciclagem;

Dear Fitter:

– Before starting montagem check as conditions of the assembly environment;
– Check out all the packaging com a list of fish contained in this manual;
– Separate the accessories, check the measures two parafuses com to scale;
– Follow all the guidelines of this manual montagem for ter or direct to guarantee of the product;
– Discard the packages correctly, allocating either plastic or paper for recycling;



01 PASSO/ PASO/ STEP

C1		2
----	---	---

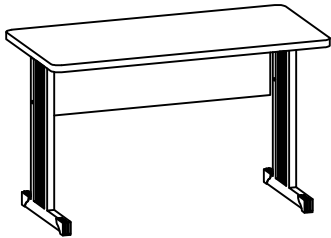
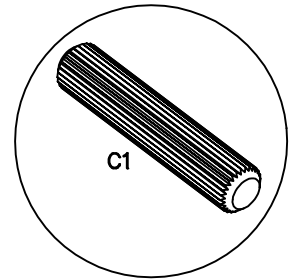
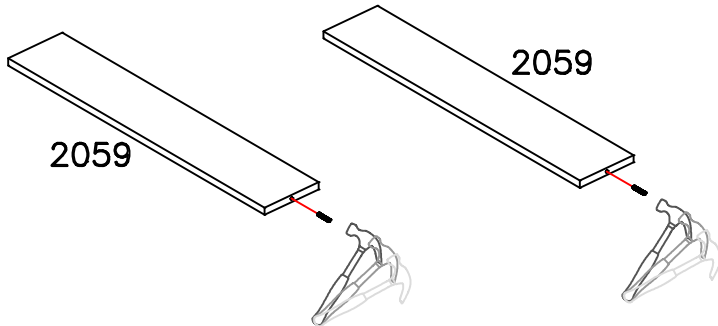

02 PASSO/ PASO/ STEP

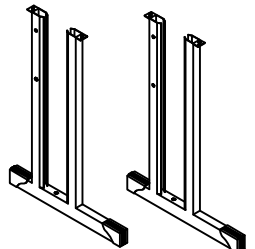
PZ		1
----	---	---

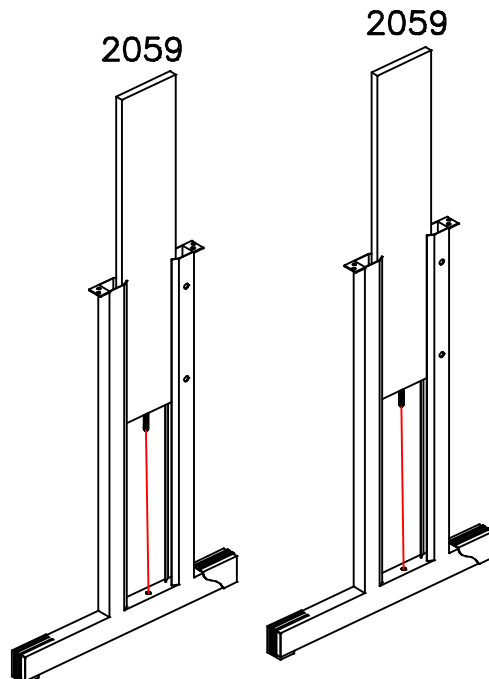
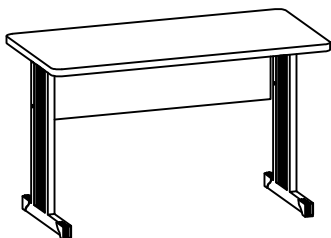

MONTAGEM/ ASSEMBLE/ ARMADO

1150

03 PASSO/ PASO/ STEP

PE12			4
CZ1			1
CPL			4
PC3			8

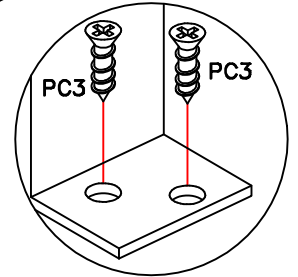
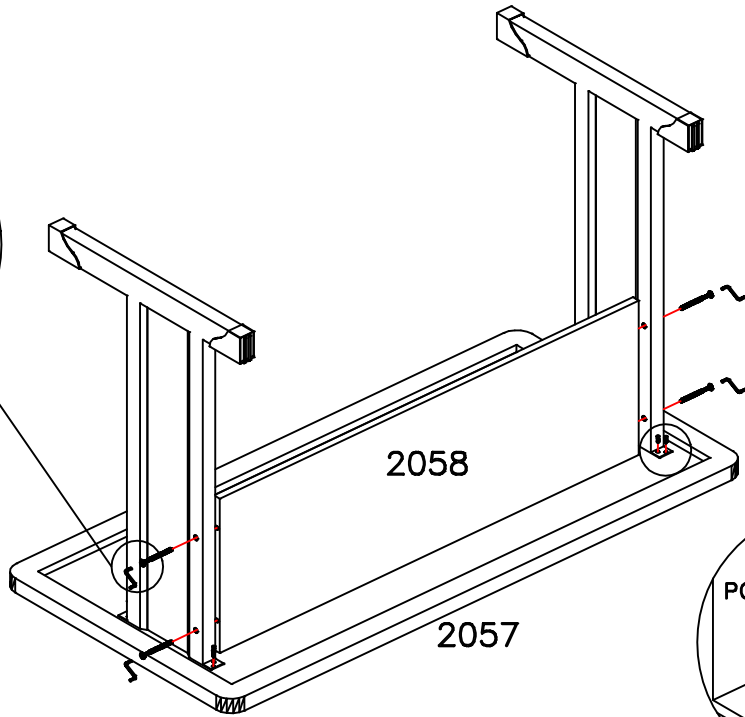
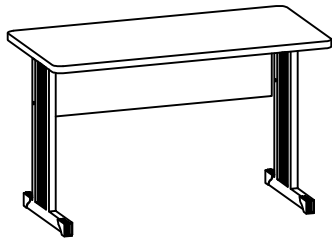
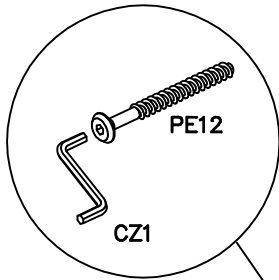
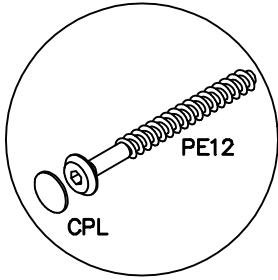

04 PASSO/ PASO/ STEP

CG			2
PC3			8

