



JCM
m o v e l a r i a

Escritaninha Alice Alice Desk Escritorio Alice



ENCONTRE UM MONTADOR
FAÇA SEU ORÇAMENTO

▶ BAIXE O APP

Cupom: JCM30



Indicamos que a montagem dos produtos seja realizada com parafusadeira eléctrica e por um montador profissional.
We recommend that a professional furniture assembler assemble the product by using a cordless screwdriver.
Se recomienda que un montador de muebles profesional realice el montaje del producto con un destornillador eléctrico.

AVISO: Não nos comprometemos pelo mal-uso, montagem e fixação do produto à parede. Portanto, não somos responsáveis por danos e quedas do produto, eletrônicos e pertences neles contidos. É importante o uso de brocas e ferramentas compatíveis na montagem.
NOTICE: The company is not responsible for the misuse, assembly, and wall fixation, as well as the damages and falls that the products, electronics, and belongings therein might suffer. It is important to use suitable drills and tools to assemble the product.
ATENCIÓN: La empresa no se responsabiliza del mal uso, montaje y fijación del producto a la pared, así como de daños y caídas del producto, electrónicos u objetos. Es importante el uso de taladros y herramientas compatibles con el montaje.

Dica: para evitar possíveis avarias, use a embalagem do produto como apoio durante a montagem.
Tip: to avoid damages, use the product packaging as a base during the assembly.
Pista: para evitar daños, use el envase del producto como apoyo durante el montaje.

RELAÇÃO DE FERRAGENS | HARDWARE LIST | LISTADO DE HERRAJES

CAVILHA 6x30	(B)	6x30 DOWEL	(B)	CLAVIJA 6x30	(B)		16
CHAPA UNIAO 4 FUROS	(C)	4-HOLE CONNECTION PLATE	(C)	PLACA DE UNIÓN 4 AGUJEROS	(C)		02
CONEXÃO ANGULAR 20x20 2 FUROS	(D)	20x20 2-HOLE CORNER BRACKET	(D)	SOPORTE ANGULAR 20x20 2 AGUJEROS	(D)		04
CONEXÃO ANGULAR 4 FUROS	(E)	4-HOLE CORNER BRACKET	(E)	SOPORTE ANGULAR 4 AGUJEROS	(E)		05
PARAFUSO CHP CHA BC 3,5x14	(F)	3.5x14 FLAT-HEAD SCREW	(F)	TORNILLO CABEZA PLANA 3,5x14	(F)		48
PARAFUSO 3,5x14 FLANGEADO	(G)	3.5x14 FLANGE SCREW	(G)	TORNILLO TIPO FLANGE 3,5x14	(G)		20
PARAFUSO ESTR CHA PHI ZP 5x40	(H)	5x40 FLAT-HEAD SCREW	(H)	TORNILLO CABEZA PLANA 5x40	(H)		12
PARAFUSO 3/16x25	(I)	3/16x25 SCREW	(I)	TORNILLO 3/16x25	(I)		02
PARAFUSO MINIFIX	(J)	MINIFIX BOLT	(J)	PERNO MINIFIX	(J)		08
PORCA 3/16	(K)	3/16 NUT	(K)	TUERCA 3/16	(K)		02
PREGO 8x8 C/C	(L)	8x8 NAIL	(L)	CLAVO 8x8	(L)		30
PUXADOR COURO 120mm	(M)	120mm SYNTHETIC LEATHER PULL	(M)	TIRADOR CUERO SINTÉTICO 120 mm	(M)		02
SAPATA DESLIZANTE	(N)	GLIDE	(N)	PATÍN	(N)		06
TAMBOR MINIFIX 12x10mm	(O)	12x10mm MINIFIX CAM LOCK	(O)	CAJA DEL MINIFIX 12x10 mm	(O)		08

RELAÇÃO DE PEÇAS | PARTS LIST | LISTADO DE PARTES

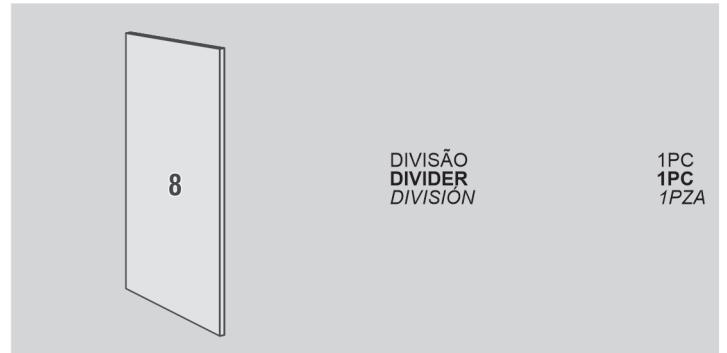
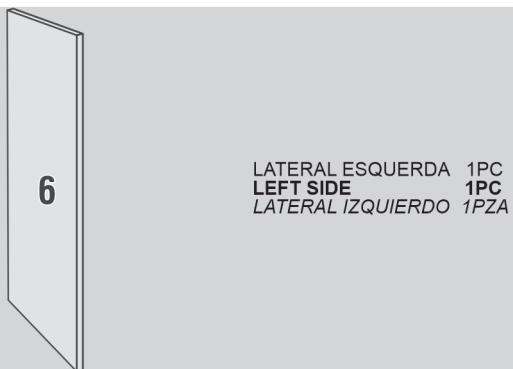
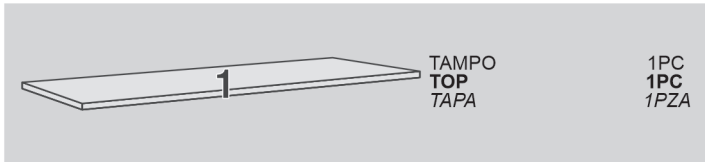
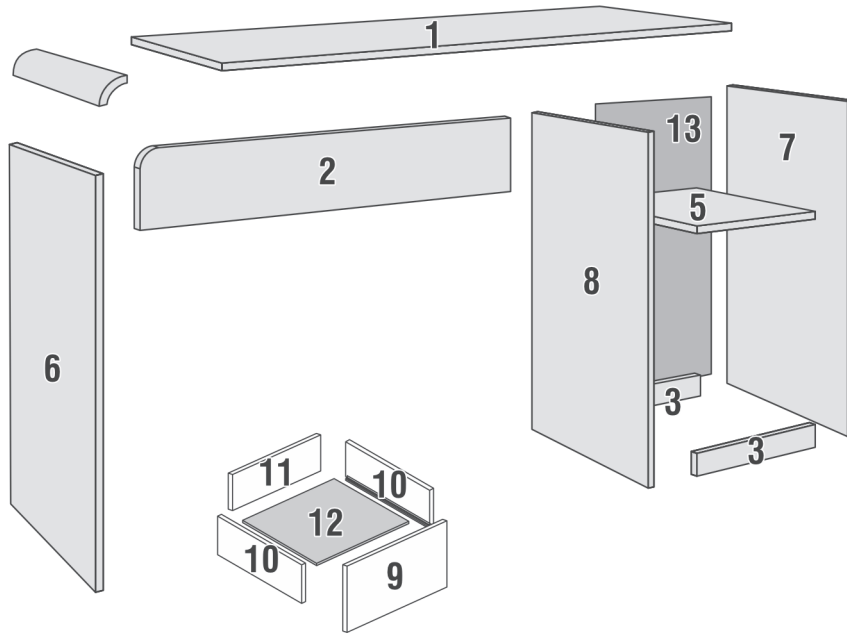

Passo 01 INICIE A MONTAGEM PELA PEÇA 1, ENCAIXANDO AS PEÇAS 7 E 8 COM MINIFIX (J+O).
Step 01 START THE ASSEMBLY FROM PART 1, BY FASTENING PARTS 7 AND 8 WITH MINIFIX (J+O).
 Paso 01 EMPIECE A ARMAR POR LA PARTE 1, FIJANDO LAS PARTES 7 Y 8 CON MINIFIX (J+O).

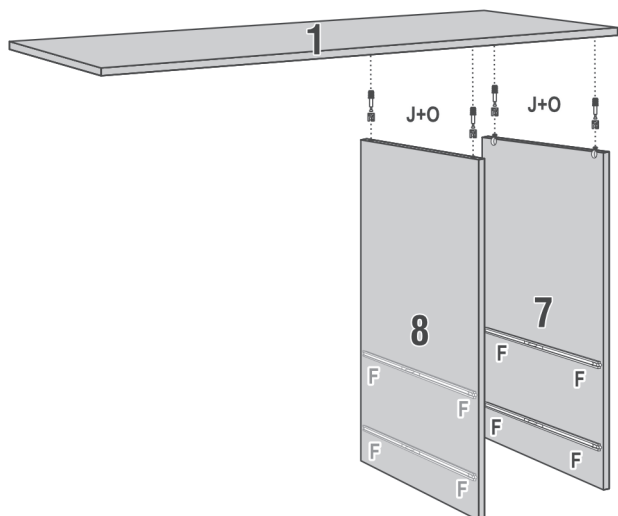

F=8

J=4

O=4

Passo 02 ENCAIXE A MOLDURA REDONDA COM CAVILHA 6x30 (B) E MINIFIX (J+O) NO TAMPO 1, E PARAFUSE COM CHAPA UNIÃO (C+F). EM SEGUIDA, ENCAIXE A PEÇA 6 NA MOLDURA REDONDA COM CAVILHA 6x30 (B) E MINIFIX (J+O).
Step 02 FASTEN THE ROUNDED CORNER FRAME TO THE TOP WITH 6x30 DOWELS (B) AND MINIFIX (J+O), AND FASTEN THE CONNECTION PLATES (C+F). NEXT, ATTACH PART 6 TO THE ROUNDED CORNER FRAME WITH 6x30 DOWELS (B) AND MINIFIX (J+O).
 Paso 02 ENCAJE EL MARCO REDONDEADO EN LA TAPA CON CLAVIJAS 6x30 (B) Y MINIFIX (J+O), Y FIJE CON PLACAS DE UNIÓN (C+F). LUEGO, FIJE LA PARTE 6 AL MARCO REDONDEADO CON CLAVIJAS 6x30 (B) Y MINIFIX (J+O).

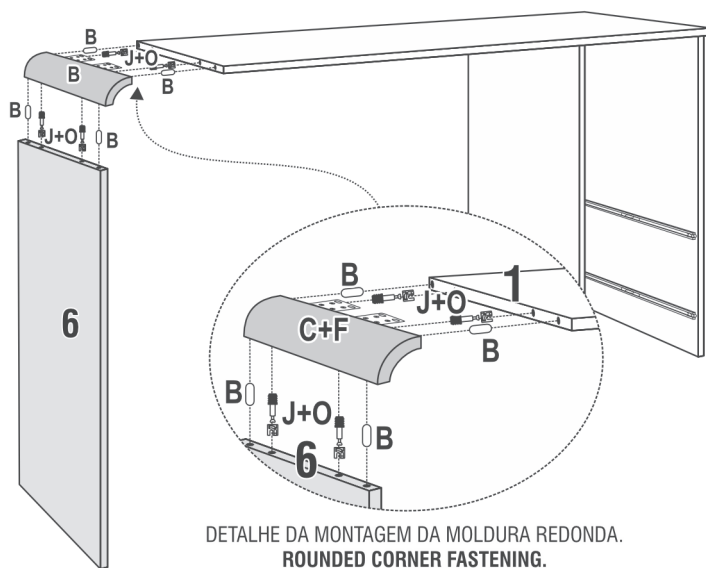

DETALHE DA MONTAGEM DA MOLDURA REDONDA.
ROUNDED CORNER FASTENING.
 ARMADO DEL MARCO REDONDEADO.

B=4

C=2

F=8

J=4

O=4

Passo 03 PARAFUSE A PEÇA 2 NAS PEÇAS 6 E 8 COM PARAFUSO 5x40 (H), E NA PEÇA 1 COM CONEXÃO ANGULAR (E+G).
Step 03 FASTEN PART 2 TO PARTS 6 AND 8 WITH 5x40 SCREWS (H), AND TO PART 1 WITH CORNER BRACKETS (E+G).
 Paso 03 FIJE LA PARTE 2 A LAS PARTES 6 Y 8 CON TORNILLOS 5x40 (H), Y A LA PARTE 1 CON SOPORTE ANGULAR (E+G).

Step 03 FASTEN PART 2 TO PARTS 6 AND 8 WITH 5x40 SCREWS (H), AND TO PART 1 WITH CORNER BRACKETS (E+G).
 Paso 03 FIJE LA PARTE 2 A LAS PARTES 6 Y 8 CON TORNILLOS 5x40 (H), Y A LA PARTE 1 CON SOPORTE ANGULAR (E+G).

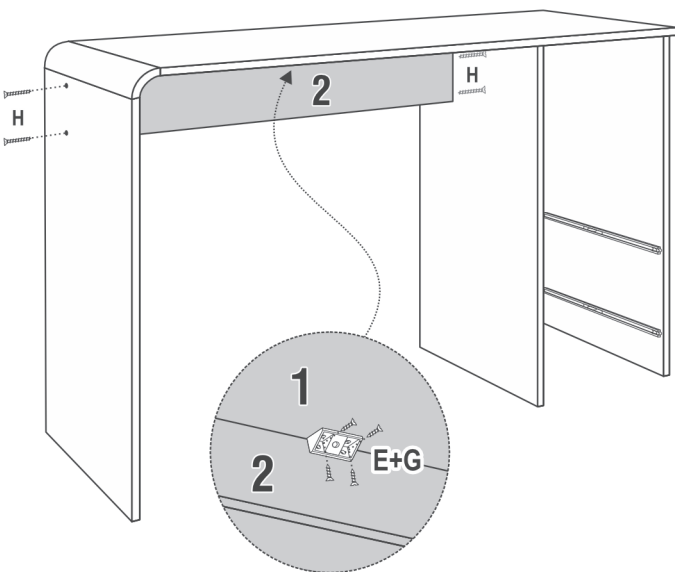

DETALHE DA CONEXÃO ANGULAR PRENDENDO A PEÇA 2 NA PEÇA 1.
THE CORNER BRACKETS PUT PARTS 2 AND 1 TOGETHER.
 EL SOPORTE ANGULAR FIJA LA PARTE 2 A LA PARTE 1.

E=4

G=4

H=4

Passo 04 PARAFUSE A PEÇA 5 NAS PEÇAS 7 E 8 COM PARAFUSO 5x40 (H).
Step 04 FASTEN PART 5 TO PARTS 7 AND 8 WITH 5x40 SCREWS (H).
 Paso 04 FIJE LA PARTE 5 A LAS PARTES 7 Y 8 CON TORNILLOS 5x40 (H).

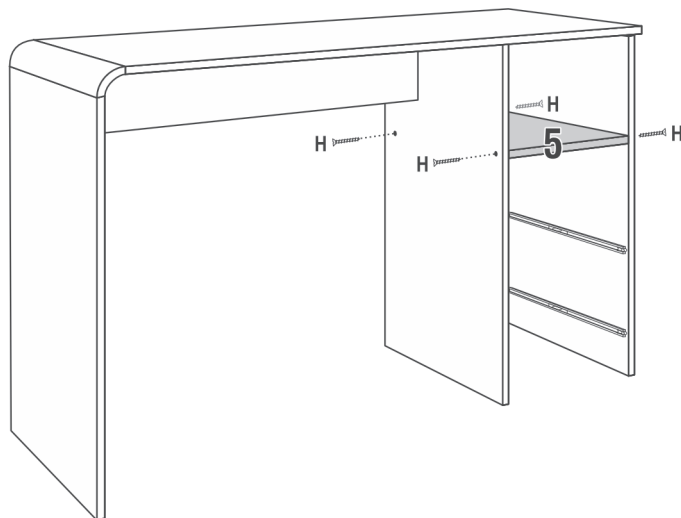



H=4

Passo 05 PARAFUSE AS PEÇAS 3 NAS PEÇAS 7 E 8 COM CONEXÃO ANGULAR (E+G).

Step 05 ATTACH PARTS 3 TO PARTS 7 AND 8 WITH CORNER BRACKETS (E+G).

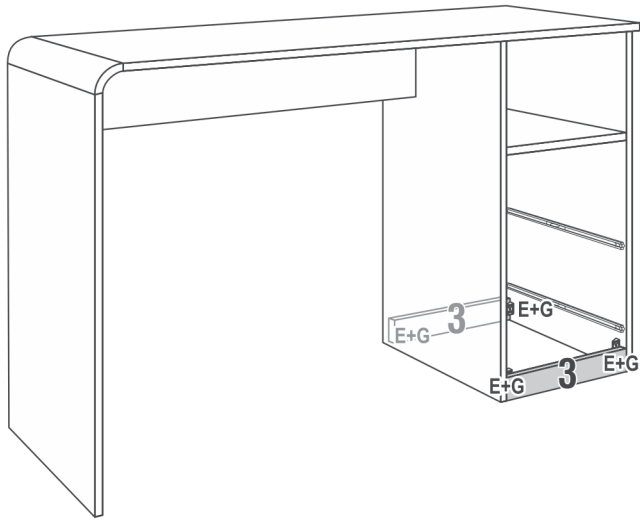
Paso 05 FIJE LAS PARTES 3 A LAS PARTES 7 Y 8 CON SOPORTE ANGULAR (E+G).



E = 4  G = 16 

Passo 06 PREGUE AS COSTAS COM PREGO (L).

Step 06 FASTEN THE BACK WITH NAILS (L).

Paso 06 FIJE LA TRASERA CON CLAVOS (L).

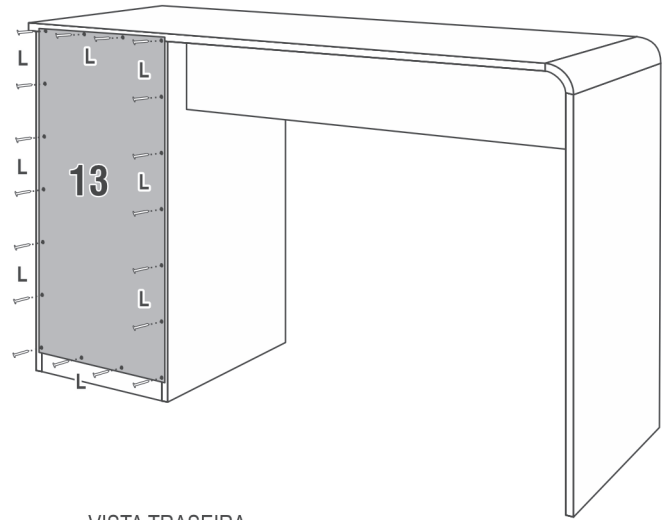

VISTA TRASEIRA
BACK VIEW
VISTA TRASERA

L = 22 

Passo 07 MONTE AS GAVETAS COM AS RESPECTIVAS FERRAGENS.

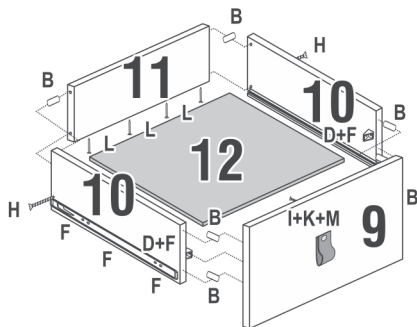

Step 07 ASSEMBLE THE DRAWERS WITH THEIR HARDWARE.

Paso 07 ARME LOS CAJONES CON SUS HERRAJES.

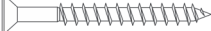

B = 12  D = 4 

F = 20  H = 4 

I = 2  K = 2  L = 8 

M = 2 

Passo 08 PARAFUSE AS SAPATAS (N+F).

Step 08 FASTEN THE GLIDES (N+F).

Paso 08 ATORNILLE LOS PATINES (N+F).

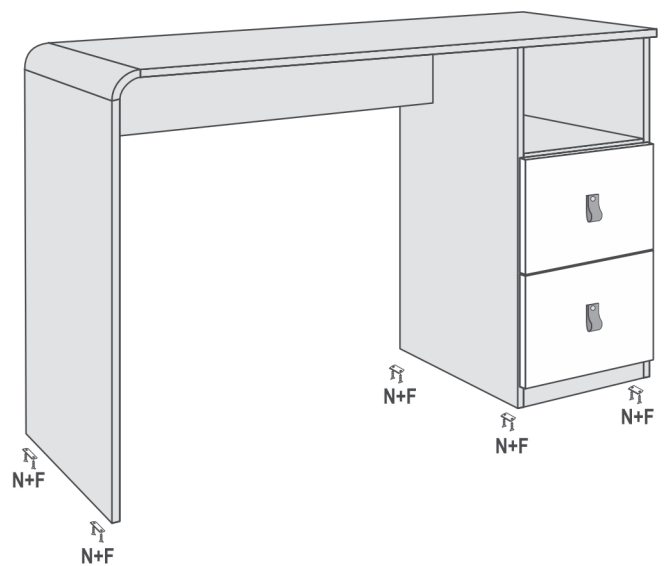

F = 12  N = 6 