

ASSEMBLY INSTRUCTIONS MANUAL DE MONTAGEM / INSTRUCCIONES DE ARMADO

SKYE CHILDREN'S TABLE

MESA INFANTIL SKYE

MESA INFANTIL SKYE

Reference
Referência
Referencia

200464

Revised
Revisão
Revisión

00



ENGLISH
PORTUGUÊS
ESPAÑOL

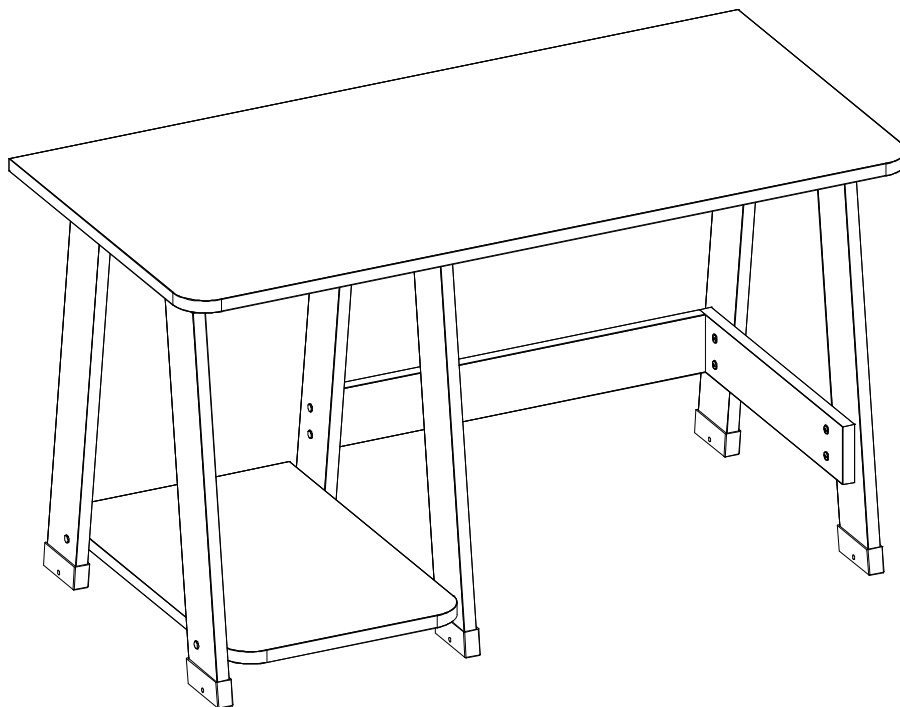

MAXIMUM RECOMMENDED WEIGHT
BEING THIS EVENLY DISTRIBUTED.

PESO MÁXIMO RECOMENDADO SENDO
ESTE DISTRIBUÍDO UNIFORMEMENTE.

PESO MÁXIMO RECOMENDADO SIENDO
ESTE UNIFORMEMENTE DISTRIBUIDO.

	LB	KG
D	11	5
F	22	10

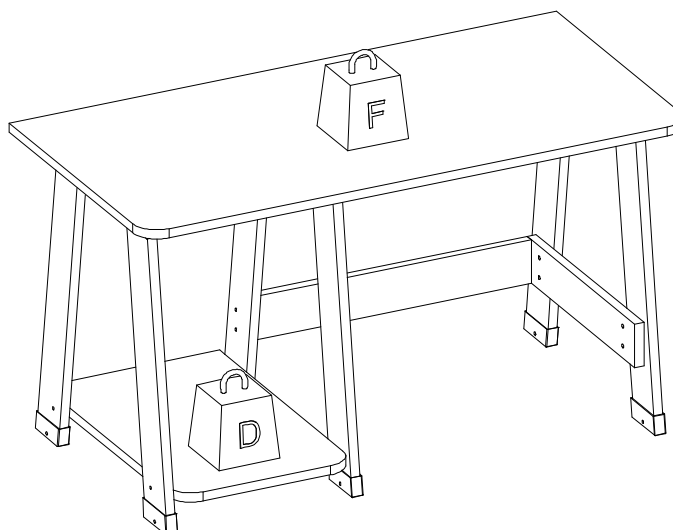

Nº	Measures_Inches	Medidas_cm	Qty./Qtd.
01	35 3/8 x 17 1/2 x 5/8	90.0 x 44.5 x 1.5	1
02	11 1/4 x 2 3/4 x 5/8	28.6 x 7.0 x 1.5	2
03	18 7/8 x 2 3/4 x 5/8	47.9 x 7.0 x 1.5	2
04	11 3/8 x 17 1/2 x 5/8	29.0 x 44.5 x 1.5	1
05	18 1/8 x 2 3/4 x 5/8	46.0 x 7.0 x 1.5	3
06	18 1/8 x 2 3/4 x 5/8	46.0 x 7.0 x 1.5	1
07	18 3/8 x 2 3/4 x 5/8	46.8 x 7.0 x 1.5	1
08	13 7/8 x 2 3/4 x 5/8	35.4 x 7.0 x 1.5	1
09	18 1/8 x 2 3/4 x 5/8	46.0 x 7.0 x 1.5	2

PARTS IDENTIFICATION
IDENTIFICAÇÃO DAS PEÇAS / IDENTIFICACIÓN DE LAS PIEZAS

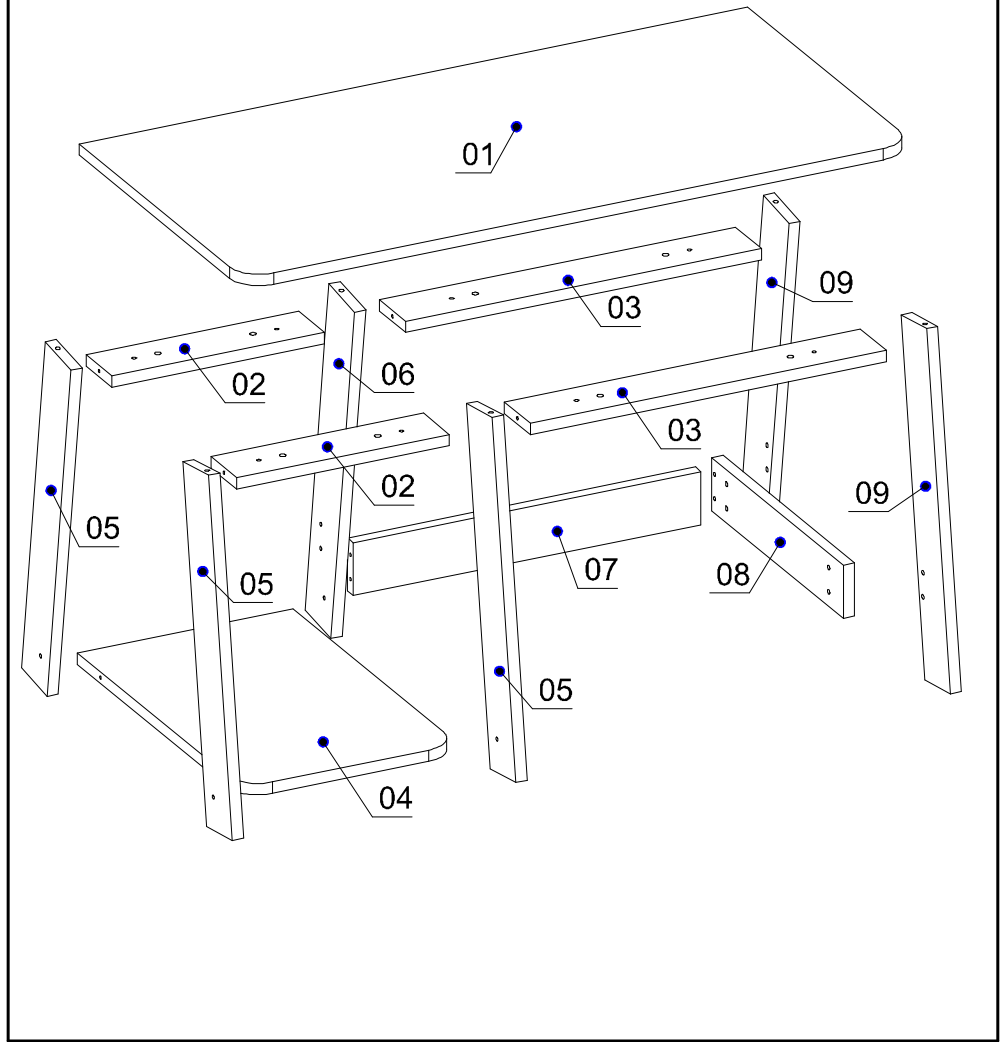

YOU WILL NEED / VOCÊ VAI PRECISAR DE / USTED NECESITARÁ

Tools not supplied / Ferramentas não fornecidas / Herramientas no incluidas

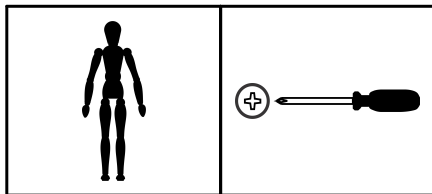

1 Person
1 Pessoa
1 Persona

Screwdriver Phillips
Chave Phillips
Destornillador cruz









The separation of the accessories before you start the assembly will facilitate the same. In case of doubt on the size of the screws and bolts, use the ruler to bottom of page 3.

A separação dos acessórios antes de iniciar a montagem facilitará a mesma. Em caso de dúvida no tamanho dos parafusos e cavilhas, utilize a régua ao final da página 3.

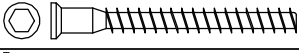
La separación de los accesorios antes de comenzar el armado facilitará el mismo. En caso de duda sobre el tamaño de los tornillos y taquetes, utilice la regla al pie de página 3.

IDENTIFICATION OF ACCESSORIES IDENTIFICAÇÃO DOS ACESSÓRIOS/ IDENTIFICACIÓN DE ACCESORIOS

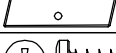
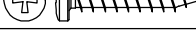
E1A		Union flanged head screw / Pf. união flangeado / Tornillo unión flangeado	4,0x10 mm	4
E1B		Union flanged head screw / Pf. união flangeado / Tornillo unión flangeado	30 mm	4
G		Structural screw / Parafuso estrutural / Tornillo estructural	5,0x50 mm	14
H		Allen key / Chave allen / Liave allen	3 mm	1
I		Structural screw cover/Tampa parafuso estrutural/Tapa tornillo estructural	-	10
N7		Wooden dowel / Cavilha / Taquete	8x20 mm	8
Q17		Inclined foot / Ponteira inclinada / Pie inclinado	-	12
R19		Pan head screw / Parafuso panela / Tornillo de pan	4,0x25 mm	32



PRE-ASSEMBLE
PRÉ-MONTAGEM / PRE ARMADO

01



ATTENTION for pin position
ATENÇÃO para posição do pino
ATENCIÓN para la posición del pasador

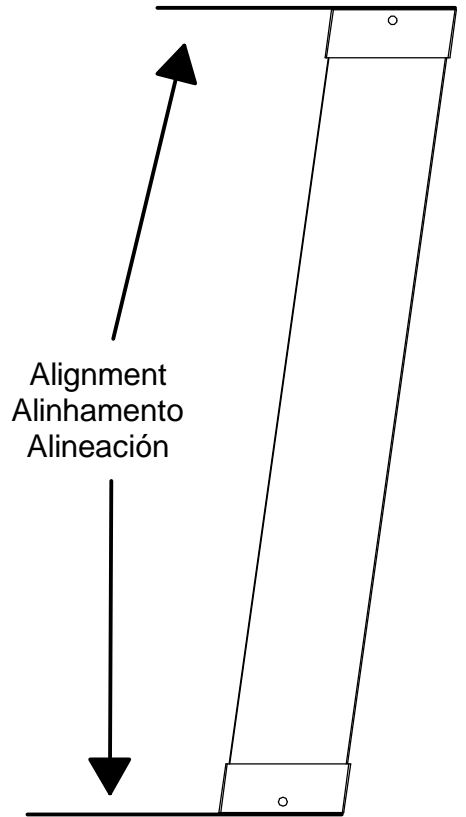
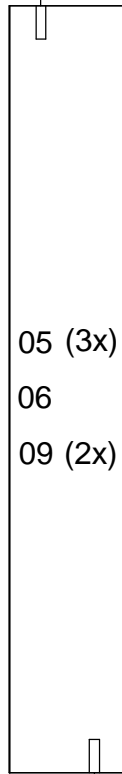
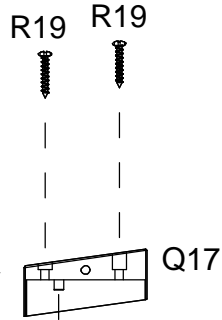
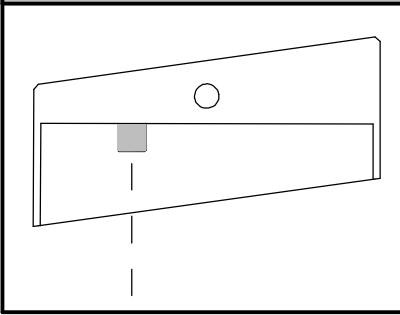

ATTENTION for pin position
ATENÇÃO para posição do pino
ATENCIÓN para la posición del pasador

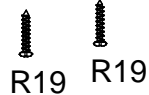
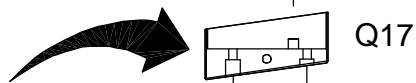
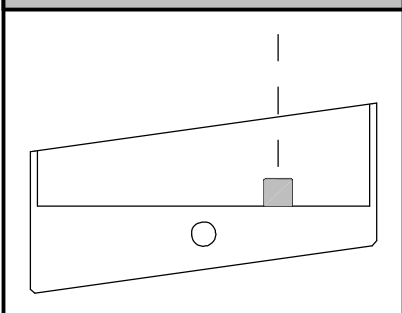

ASSEMBLY
MONTAGEM / ARMADO

02

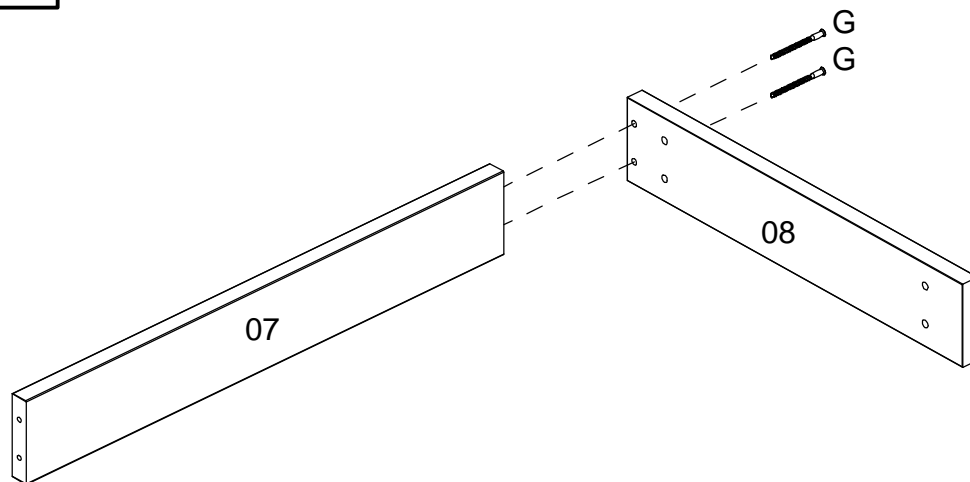
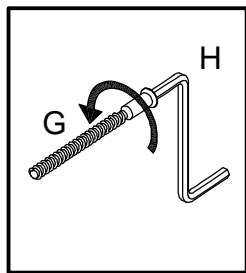

03

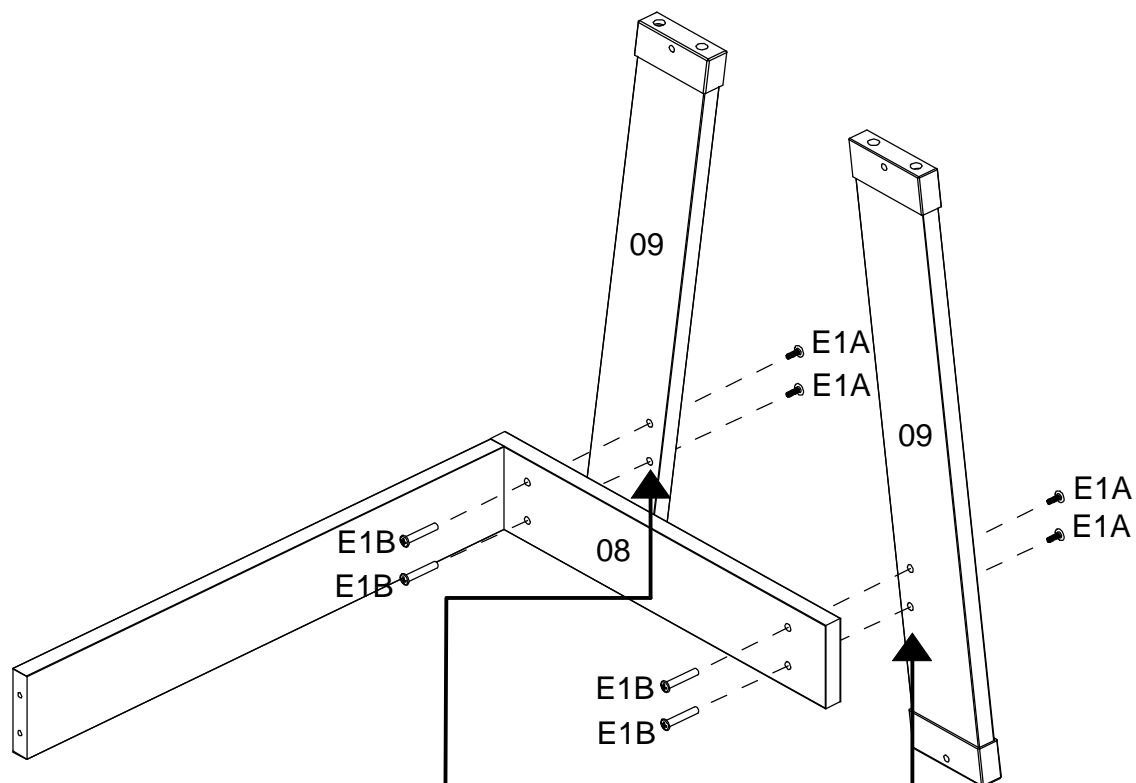

ATTENTION for the hole position.
ATENÇÃO para a posição da furação.
ATENCIÓN para la posición del agujero.

04

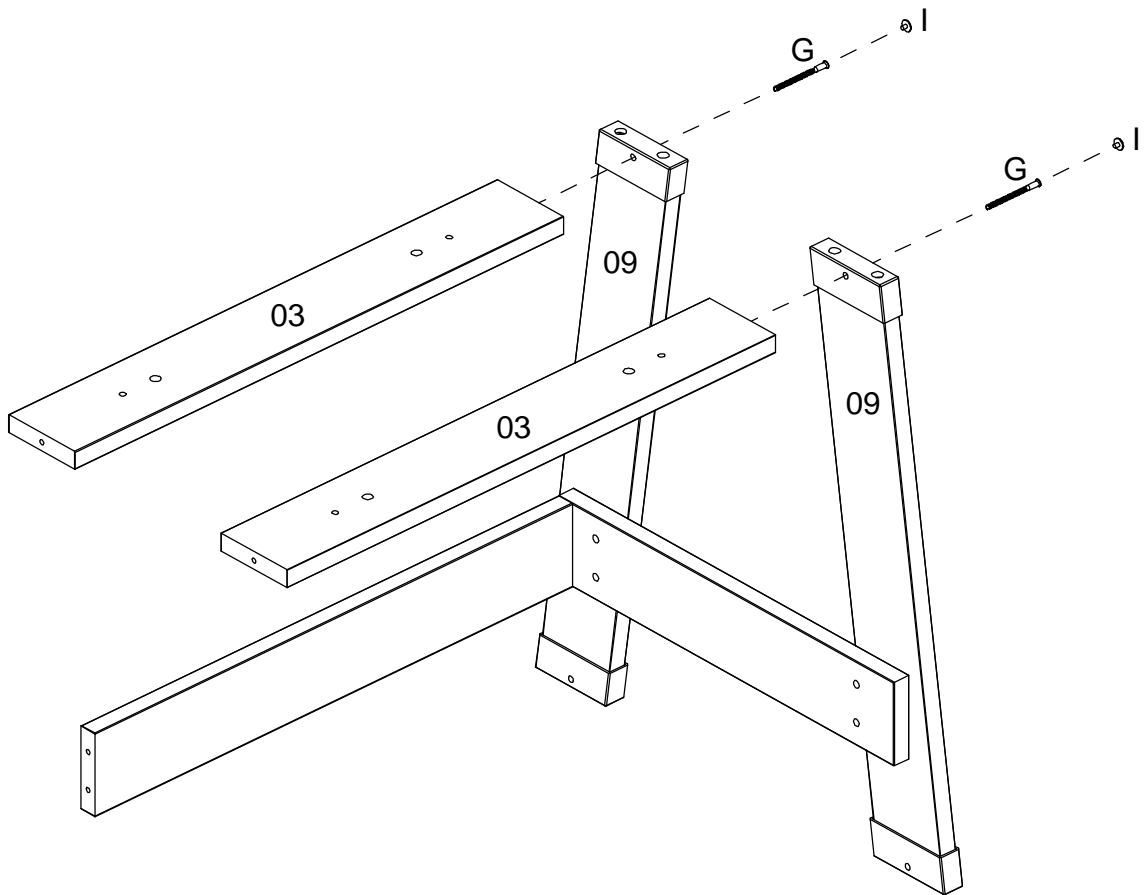

05

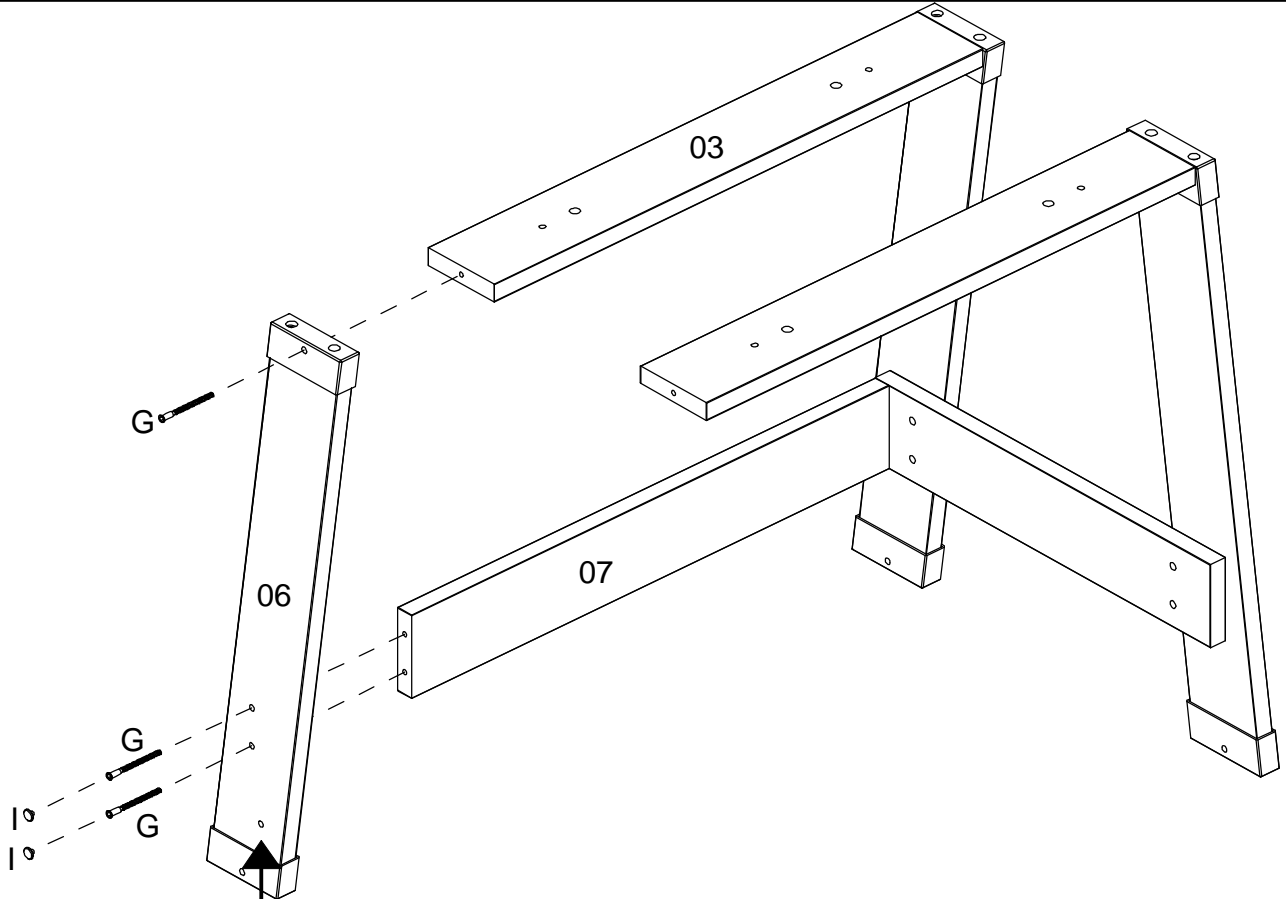

ATTENTION for the hole position.
ATENÇÃO para a posição da furação.
ATENCIÓN para la posición del agujero.

06

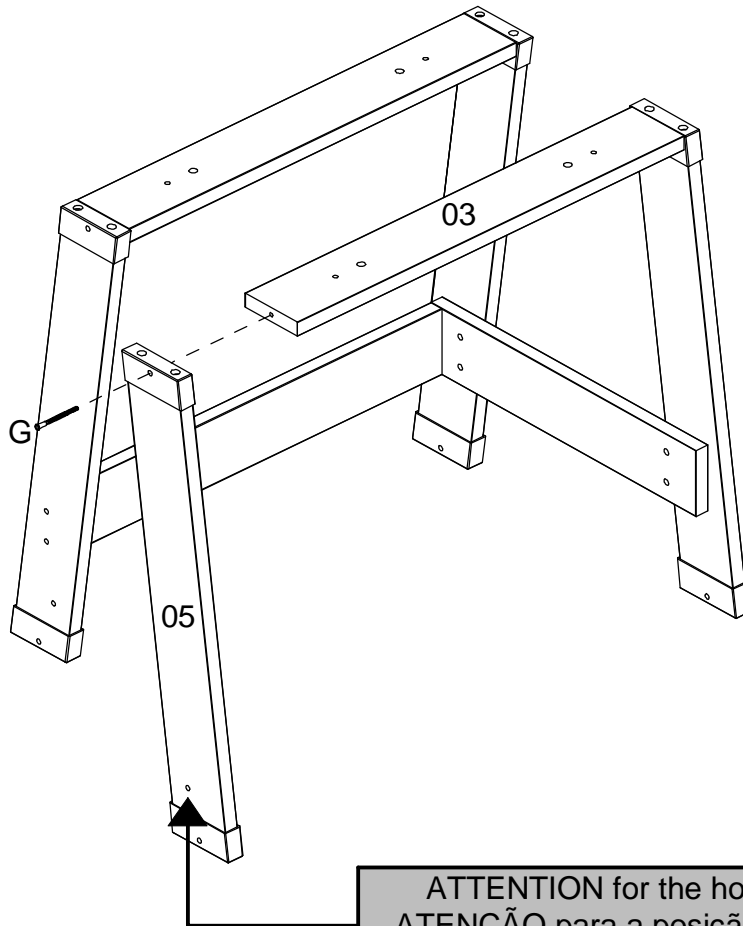

ATTENTION for the hole position.
ATENÇÃO para a posição da furação.
ATENCIÓN para la posición del agujero.

07

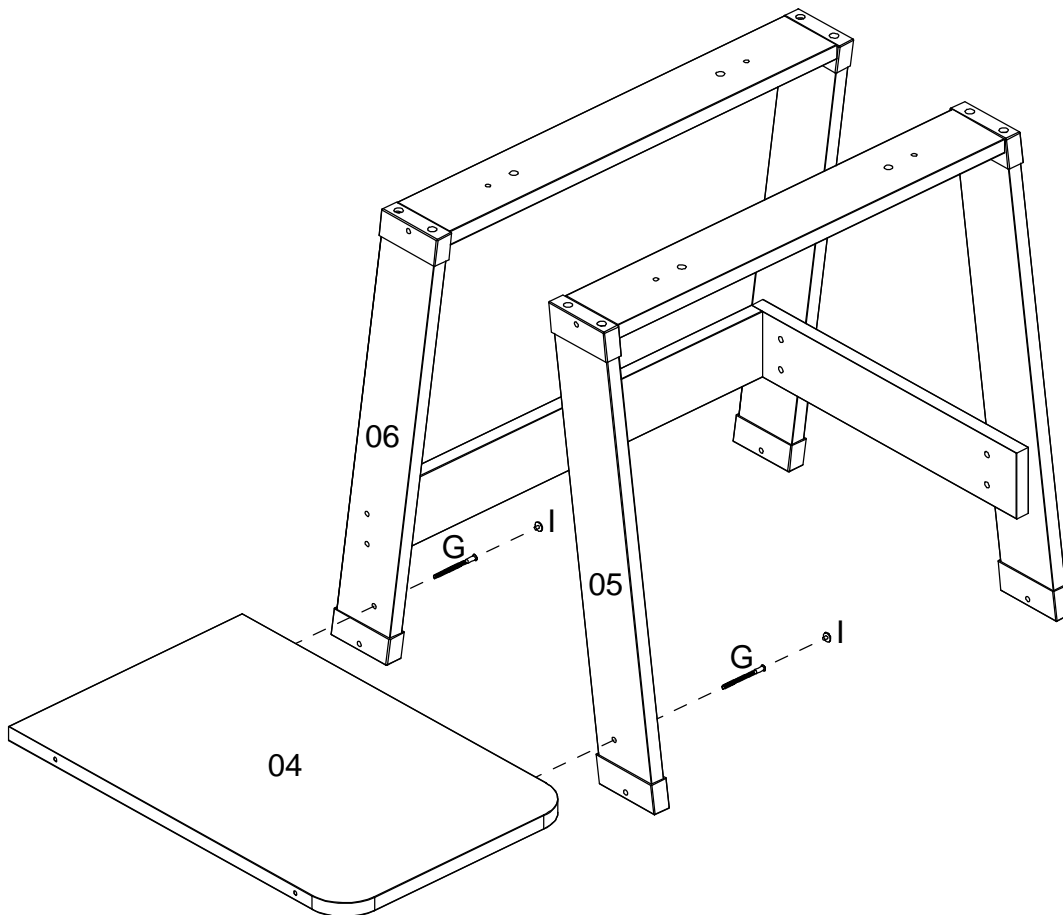

08

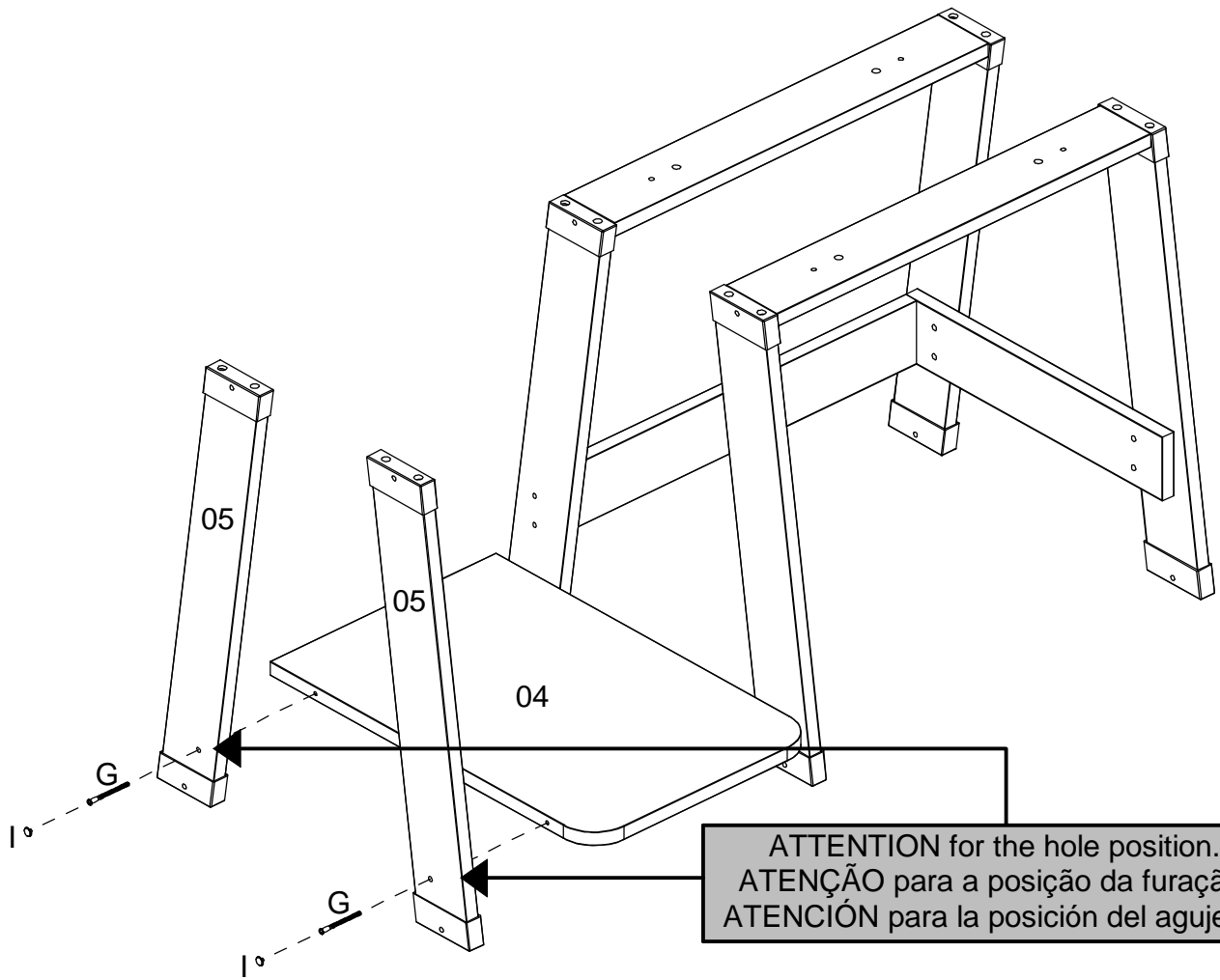

09

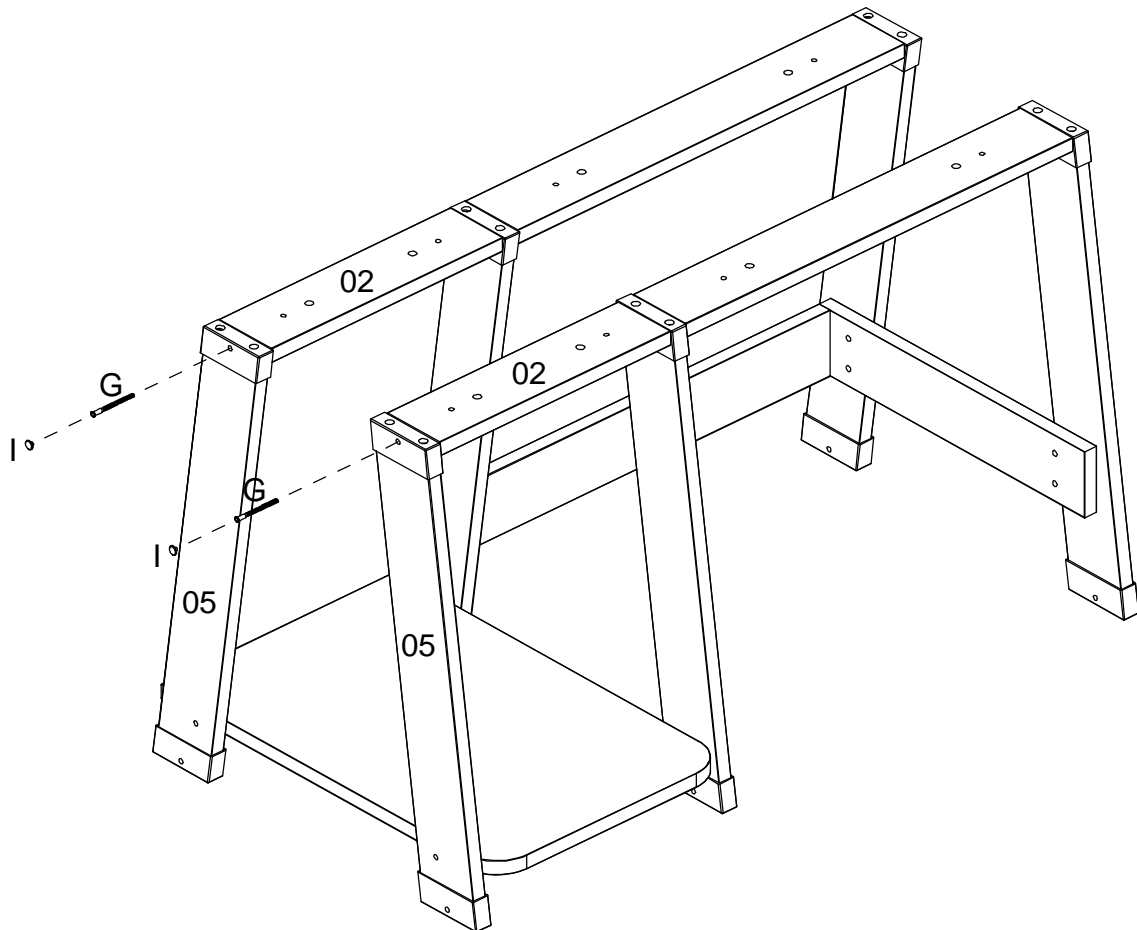

10

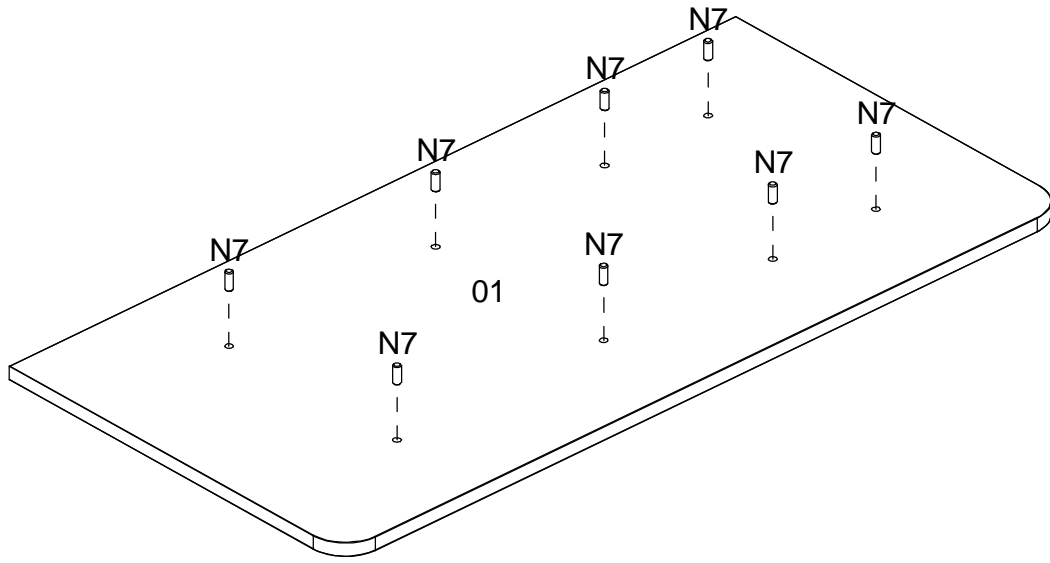

11

