

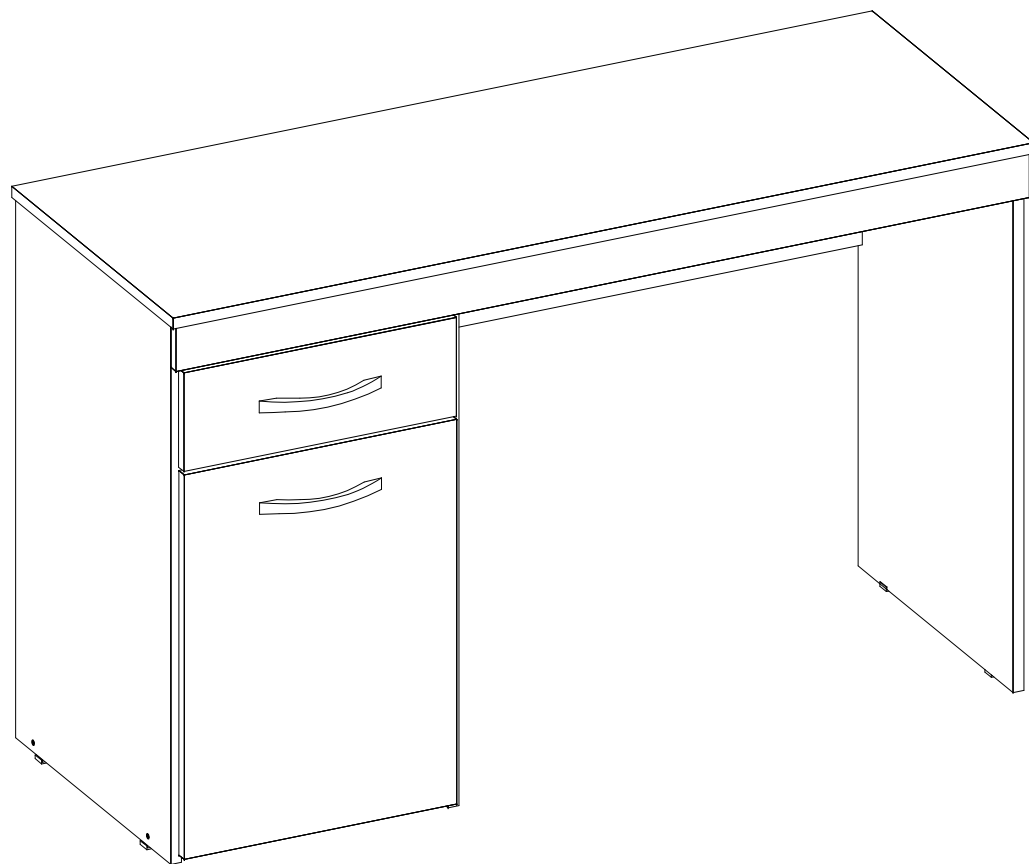

DEMÓBILE



29100 ESCRIVANINHA 01 PORTA VITORIA

29100 WHRITING DESK 01 DOOR VITORIA

29100 ESCRITORIO 01 PUERTA VITORIA

29100

**ESCRIVANINHA 01 PORTA VITORIA
WHIRTING DESK 01 DOOR VITORIA
ESCRITORIO 01 PUERTA VITORIA**

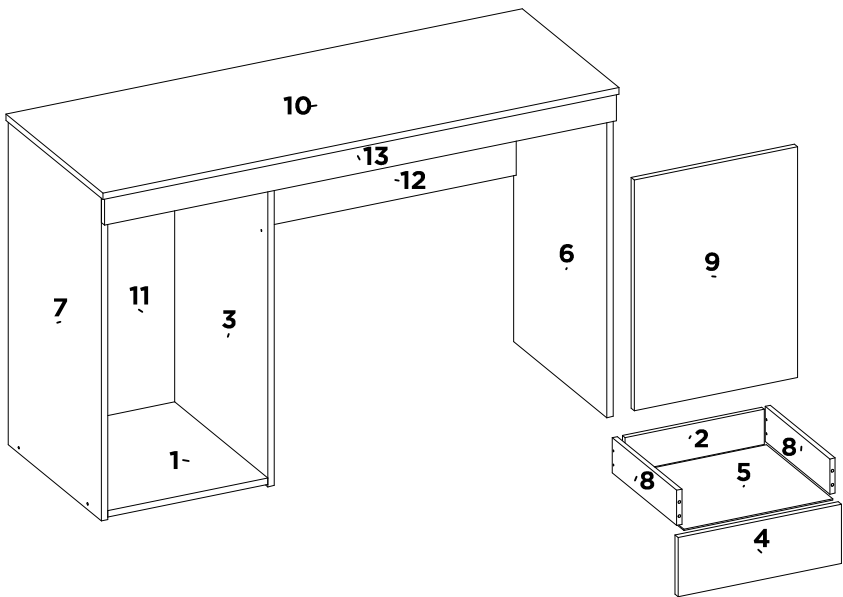

SEQ.	CODIGO	REF_01	REF_02	REF_03	REF_04	REF_05	REF_06	DESCRICAO	DESCRIPTION_EN	DESCRIPCION_ES	DIMENSÕES_MM	QTD
1	03124	03	113	-	-	-	-	BASE	BASE	BASE	433 X 372 X 15	1
2	06111	03	113	-	-	-	-	CONTRA FUNDO	DRAWER BACK	CONTRA FONDO	324 X 80 X 12	1
3	08244	03	111	-	-	-	-	DIVISAO ESQUERDA	LEFT DIVISION	DIVISION IZQUIERDA	740 X 433 X 15	1
4	09150	03	111	-	-	-	-	FRENTE DE GAVETA	DRAWER FRONT	FRENTE DEL CAJON	380 X 135 X 15	1
5	10093	03	113	-	-	-	-	FUNDO GAVETA	DRAWER BASE	FONDO DEL CAJON	346 X 308 X 3	1
6	11324	03	111	-	-	-	-	LATERAL DIREITA	RIGHT SIDE PANEL	LATERAL DERECHA	740 X 433 X 15	1
7	11325	03	111	-	-	-	-	LATERAL ESQUERDA	LEFT SIDE PANEL	LATERAL IZQUIERDA	740 X 433 X 15	1
8	12016	03	113	-	-	-	-	LATERAL DE GAVETA	DRAWER SIDE	LATERAL DEL CAJON	300 X 80 X 12	2
9	14249	03	111	-	-	-	-	PORTA	DOOR	PUERTA	526 X 380 X 15	1
10	19197	03	111	-	-	-	-	TAMPO	TOP	TAPA	1200 X 450 X 15	1
11	20339	03	113	-	-	-	-	TRASEIRO	BACK PANEL	TRASERO	743 X 398 X 3	1
12	27045	03	111	-	-	-	-	PAINEL TRASEIRO	REAR PANEL	PANEL TRASERO	773 X 296 X 12	1
13	29070	03	111	-	-	-	-	VISTA	VIEW	VISTA	1190 X 60 X 15	1

DEMÓBILE Indústria de Móveis Ltda.
Rua : Jurutau, 1350 - Pq. Industrial II.
Cep.: 96703-070
Arapongas - PR - Brasil
demobile@demobile.com.br

CERTIFICADO 90 DIAS GARANTIA

- Avisos**
1. Ler atentamente as instruções do manual antes de iniciar a montagem do móvel.
 2. A montagem deverá ser feita em superfície limpa e plana, aconselhamos forrar o chão com a embalagem do produto, para não danificar.
 3. Os parafusos devem ser apertados periodicamente.
 4. Evitar batidas e contato com objetos cortantes.
 5. O peso máximo de carga informado refere-se a objetos distribuídos de maneira uniforme sobre toda área de contato da peça.

Limpeza e Conservação
Efetuar a limpeza somente com pano macio limpo e seco.
Não Utilizar produtos abrasivos ou químicos.

Garantia
1.O fabricante responsabiliza-se apenas pelas peças do produto.
2.A montagem incorreta acarretará na perda da garantia e das assistências, desta forma o produto deverá ser montado por profissional qualificado.
3.Não estão cobertos pela garantia problemas que tenham origem na utilização inadequada do produto ou na exposição do mesmo a intempéries como: infiltrações, infestação de pragas em geral, aparecimento de mofo e outros, decorrentes do ambiente de instalação.

Assistência Técnica: Em caso de peças em assistência técnica é necessário que as mesmas sejam solicitadas junto a loja ou site no qual a compra do produto foi realizada.

- Warnings**
1. Read the manual instructions carefully before starting to assemble the furniture.
 2. The assembly must be done in clean and flat surface, we advise to put the product packaging on the floor, not to damage it during the assembling.
 3. The screws must be tightened periodically.
 4. Avoid hitting and contacting sharp objects.
 5. The payload informed refers to the objects distributed all over the piece contact area.

Cleaning and conservation
Clean the product just with a soft, cleaned and dry cloth.
Do not use abrasive or chemicals products.

- Warranty**
- 1.The manufacturer is only responsible for product parts.
 2. Incorrect assembling will make you lost the guarantee and assistance, in this way the product must be assembled by qualified professional.
 3. It is Not covered by the warranty problems caused by an inappropriate use of the product or product exposure even in bad weather, such as: infiltrations, pest infestation in general, appearance of mold and others, caused by the installation environment.

Technical Assistance: Damaged pieces! Ask on the stores you bought it.

- Advertencias**
1. Lee atentamente las instrucciones del manual antes de empezar a armar los muebles.
 2. El montaje debe hacerse en superficie limpia y plana, utilice el empaque del Producto para cubrir el piso.
 3. Los tornillos deben ser apretados periodicamente
 4. Evite golpear y chocar objetos punzantes
 5. El peso máximo de carga tiene relación a los objetos distribuidos sobre toda el área de contacto de la pieza.

Limpeza y conservación
Limpiar solo con un trapo suave, limpio y seco
No utilice productos abrasivos o productos químicos

- Garantía**
- 1.El fabricante solo es responsable a las partes del producto.
 2. Armar incorrectamente supone la pérdida de garantía y repuestos, de esta manera el producto debe ser ensamblado por profesional calificado
 - 3.No es garantizado problemas derivados del uso inapropiado del producto, o exposición del producto al mal tiempo, como: infiltraciones, infestación de plagas en general, aparición de moho y otros.

Asistencia técnica: en caso de piezas rotas es necesario que sea solicitadas las mismas a la tienda o sitio web donde se compró el producto.



**COMPLETE MANUAL
MANUAL COMPLETO**

Acessórios/Accories/Accessories/Acessórios

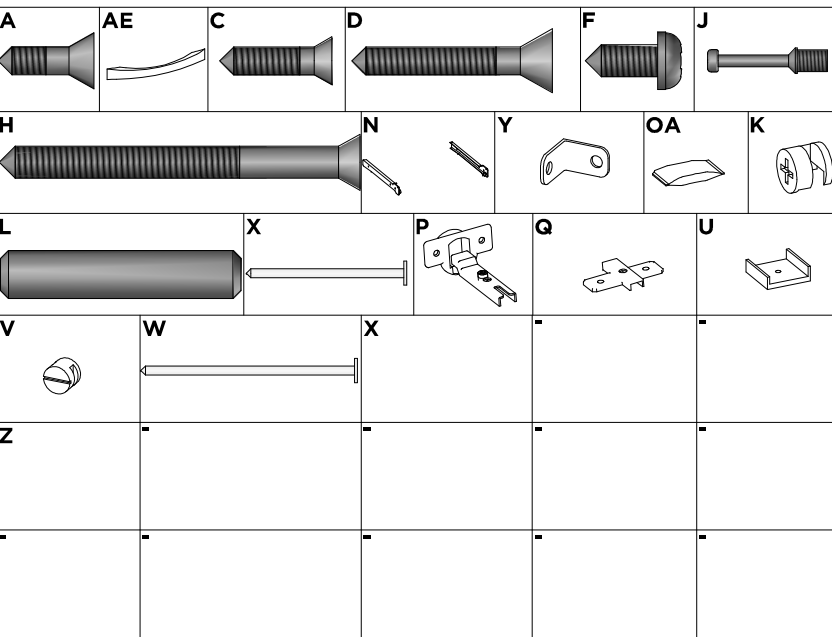

LISTA DE ACESSÓRIOS / LIST OF ACCESSORIES / LISTA DE ACCESORIOS

SEQ.	CODIGO.	DESCRIÇÃO	DESCRIPTION_EN	DESCRIPCION_ES	QTD.
A	9905002	PARAFUSO 3.5 X 12 MM CHATA PHILIPS	PHILIPS FLAT HEAD SCREW	TORNILLO CHATA PHILIPS	18
AE	9904021	PUXADOR ALPHA F 128 MM PRATA	HANDLE	TIRADOR	2
C	9905046	PARAFUSO 3.5 X 14 MM CHATA PHILIPS	PHILIPS FLAT HEAD SCREW	TORNILLO CHATA PHILIPS	6
D	9905018	PARAFUSO 3.5 X 25 MM CHATA PHILIPS	PHILIPS FLAT HEAD SCREW	TORNILLO CHATA PHILIPS	8
F	9905007	PARAFUSO 4 X 12 MM PANELA PHILIPS	PANHEAD SCREW	TORNILHO CABEZERA DE OLHA	8
H	9905045	PARAFUSO 4 X 45 MM CHATA PHILIPS	PHILIPS FLAT HEAD SCREW	TORNILLO CHATA PHILIPS	8
J	9920029	PINO MINIFIX 12 MM	MINIFIX PIN	PINO MINIFIX	4
K	9920009	CASTANHA MINIFIX 12 MM	MINIFIX CHESTNUT	LOS SIMPSON	4
L	9920011	CAVILHAS 6 X 30 MM	WOODEN PEG	CLAVIA DE MADERA	14
N	9913009	CORREDICA 300 MM METAL LIGHT	METAL SLIDE	RIEL METALICO	1
OA	9912006	SACHET DE COLA 10 GRAMAS	GLUE	COLA	1
P	9920020	DOBRADICA ALTA 26 MM ESTAMPADA	HINGE	BISAGRA	2
Q	9920005	CALCO DOBRADICA 5 MM	CHOCK	CALCE	2
U	9924002	MINI SAPATA 15 MM	MINI SHOE	MINI ZAPATA	6
V	9920030	PORCA CILINDRICA 9 X 12 MM	CYLINDRICAL NUT	TUERCA CILINDRICA	8
W	9906001	PREGO 12X12 MM	NAIL	CLAVO	6
X	9906002	PREGO 9X9 MM	NAIL	CLAVO	25
Y	9920006	CANTONEIRA METALICA 16 MM	METAL ANGLE BRACKET	ESQUINERAS METALICAS	6

01

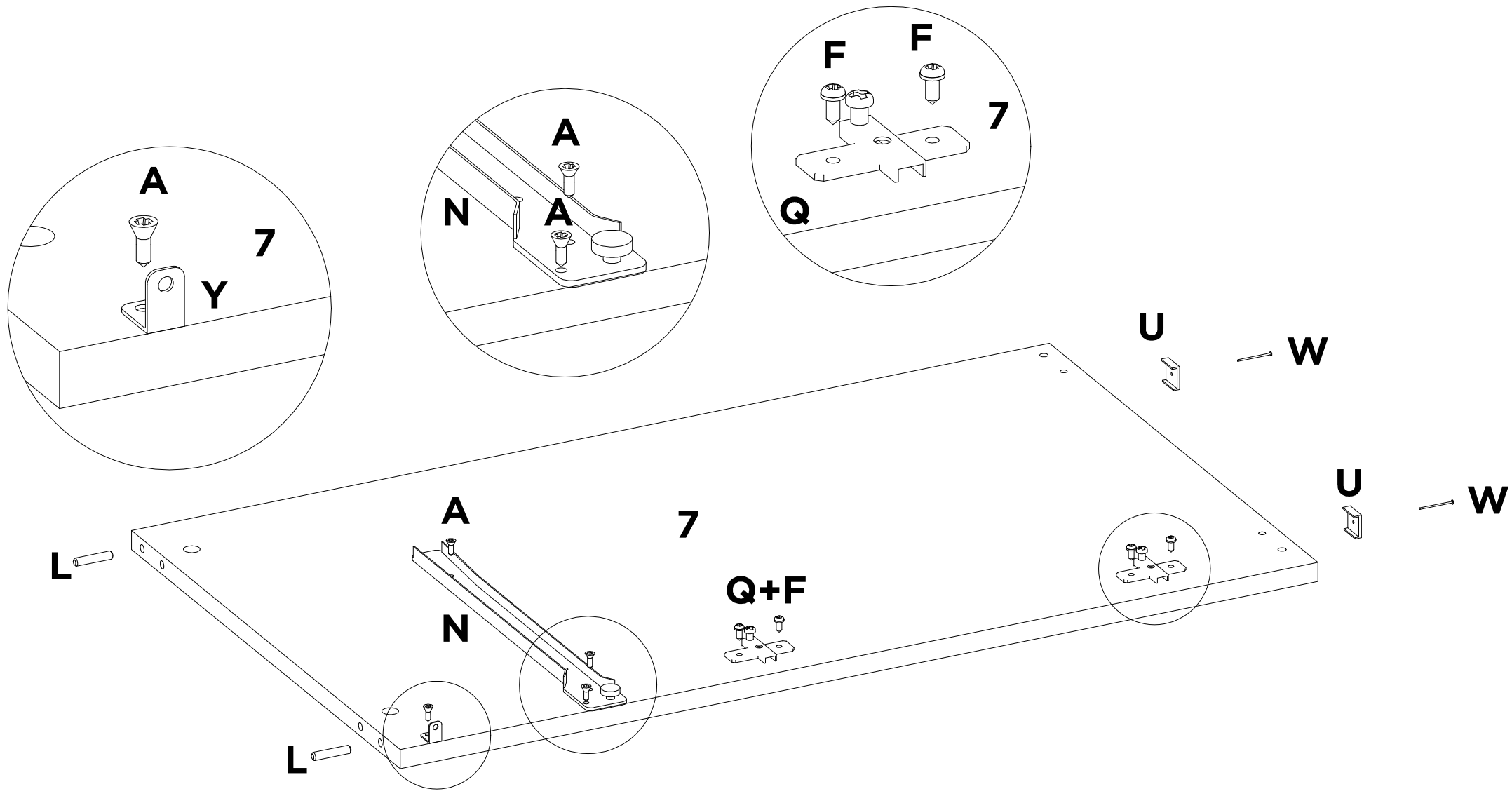

L	Y	A	F	Q	U	W	-
X2	X1	X4	X4	X2	X2	X2	-

02

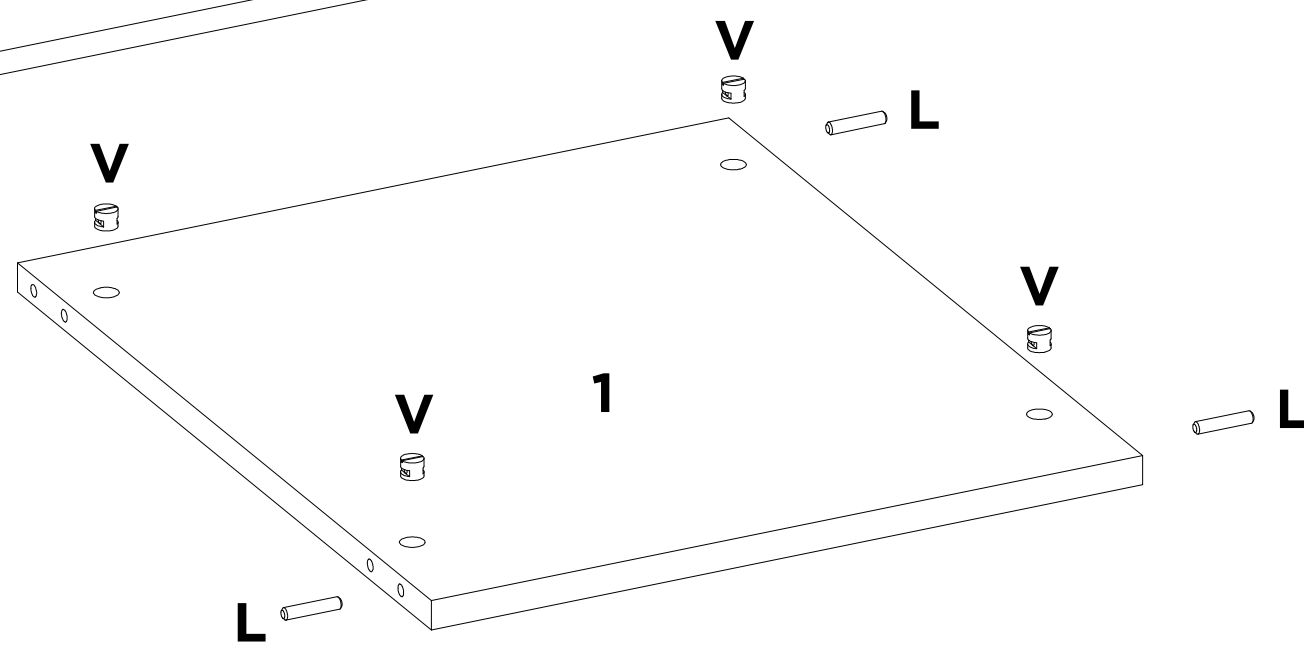
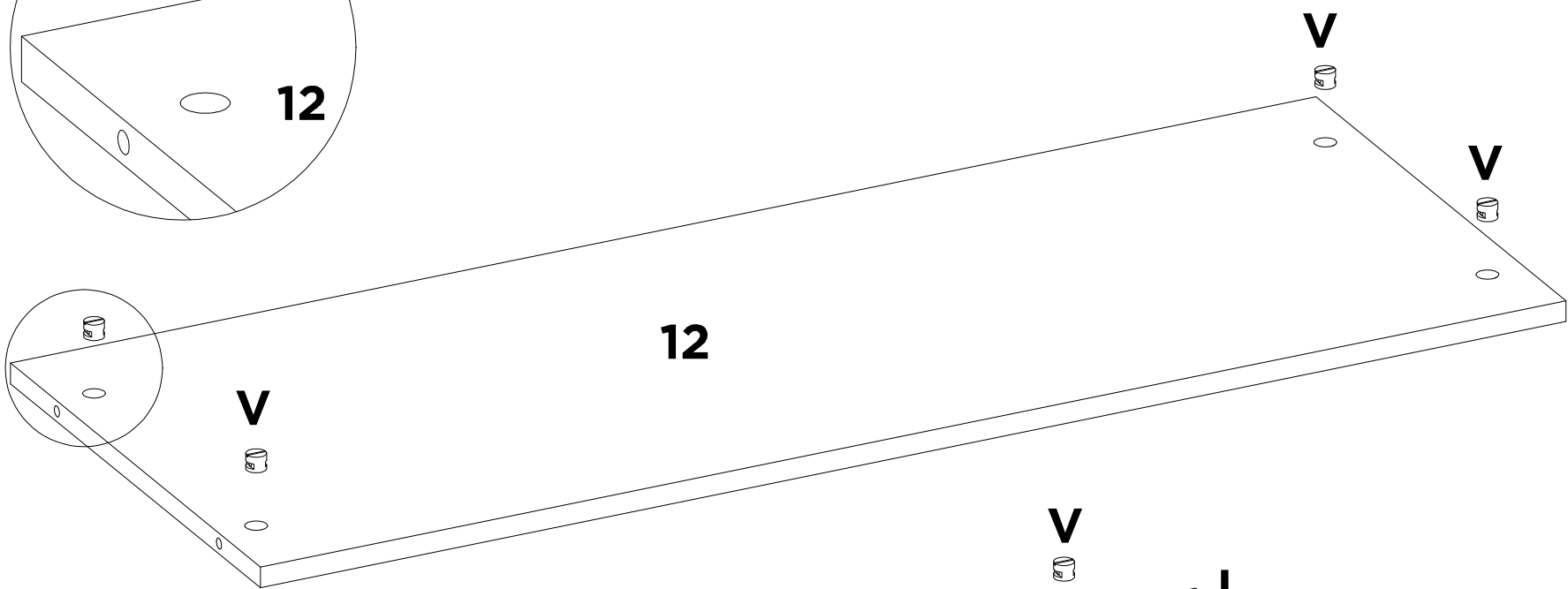
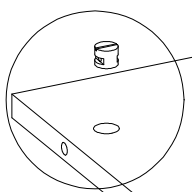
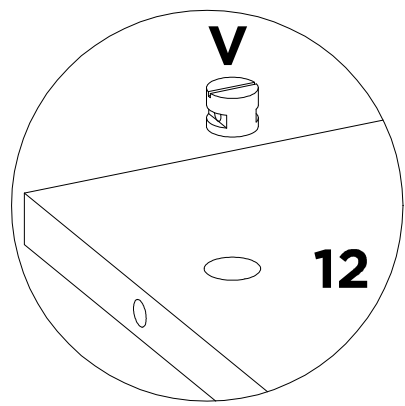

V X8

L X4

- -

- -

- -

- -

- -

- -

03

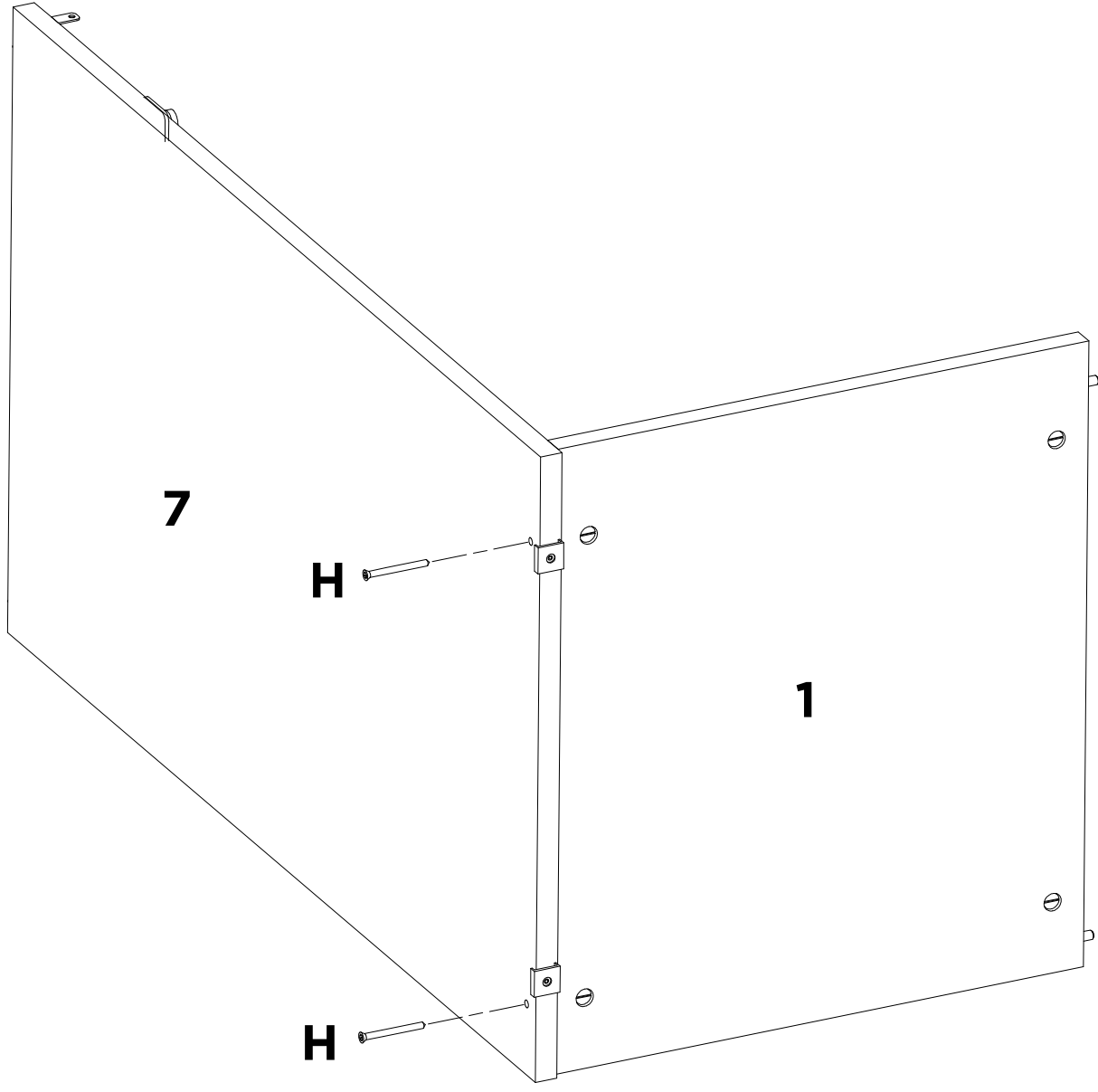

H
X2

-	-	-	-	-	-	-	-
---	---	---	---	---	---	---	---

04

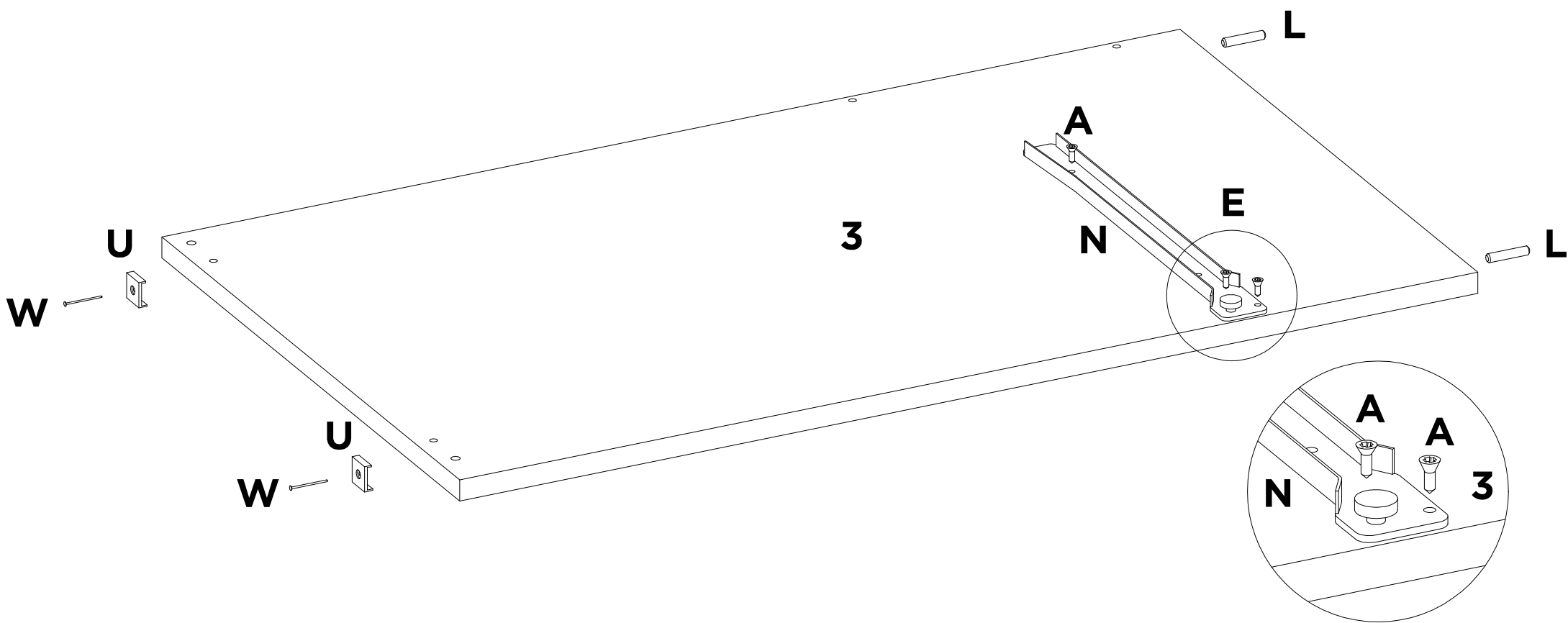

L	N	A	U	W	-	-	-
X2	X1	X3	X2	X2	-	-	-

05

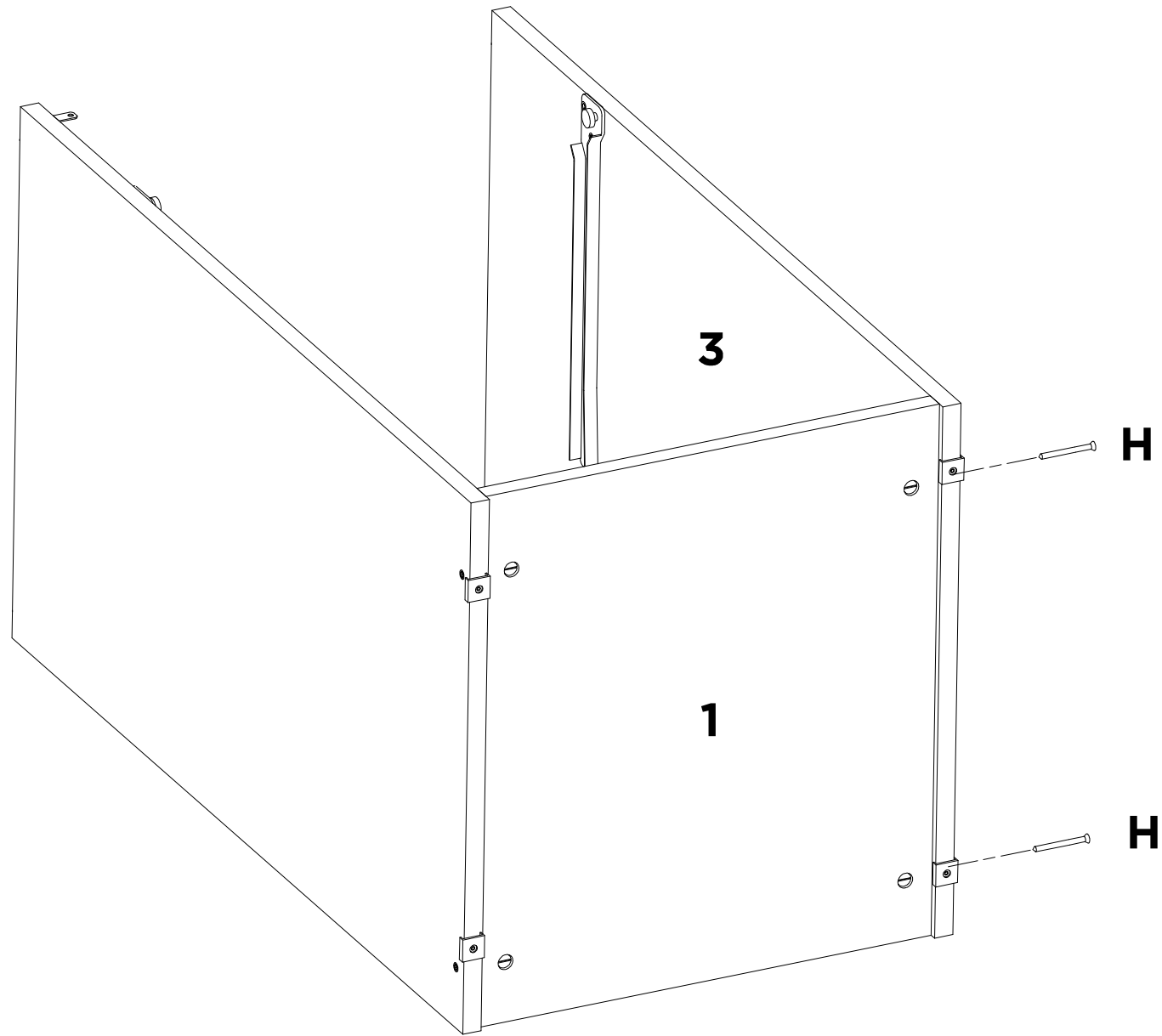

H

X2

-

-

-

-

-

-

-

-

-

-

-

-

-

-

06

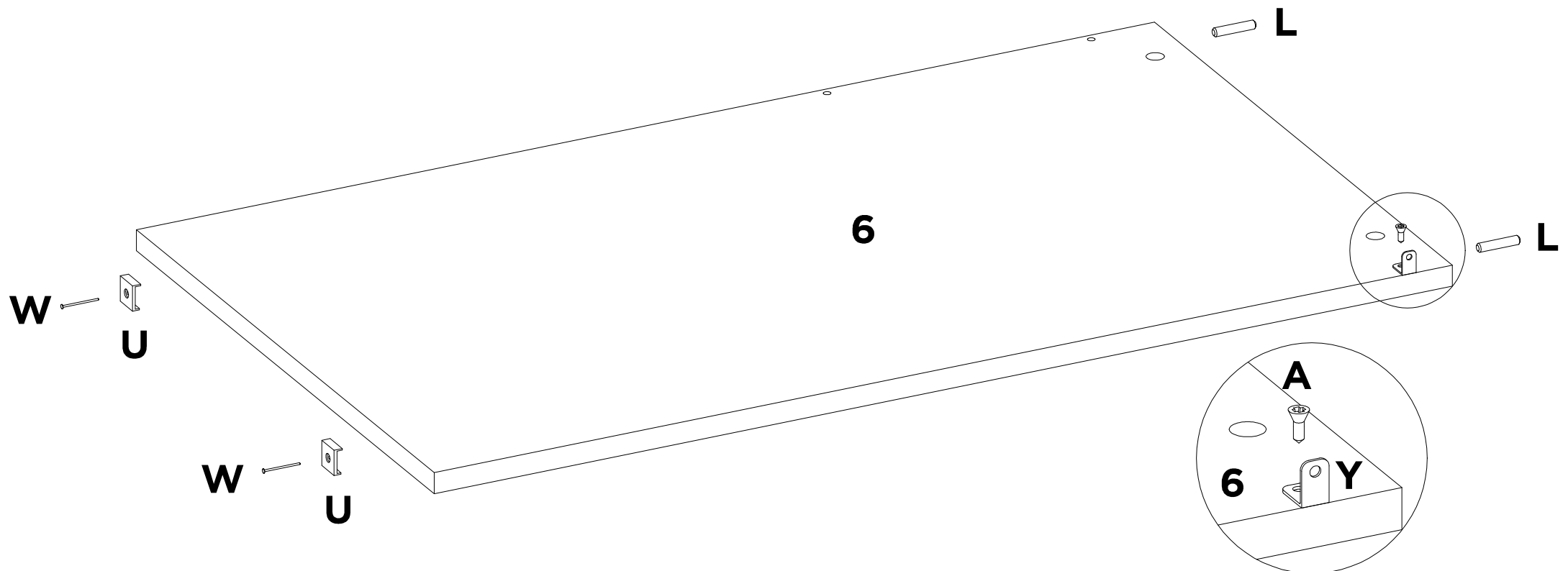

W X2	U X2	L X2	A X1	Y X1	- -	- -	- -
----------------	----------------	----------------	----------------	----------------	--------	--------	--------

07

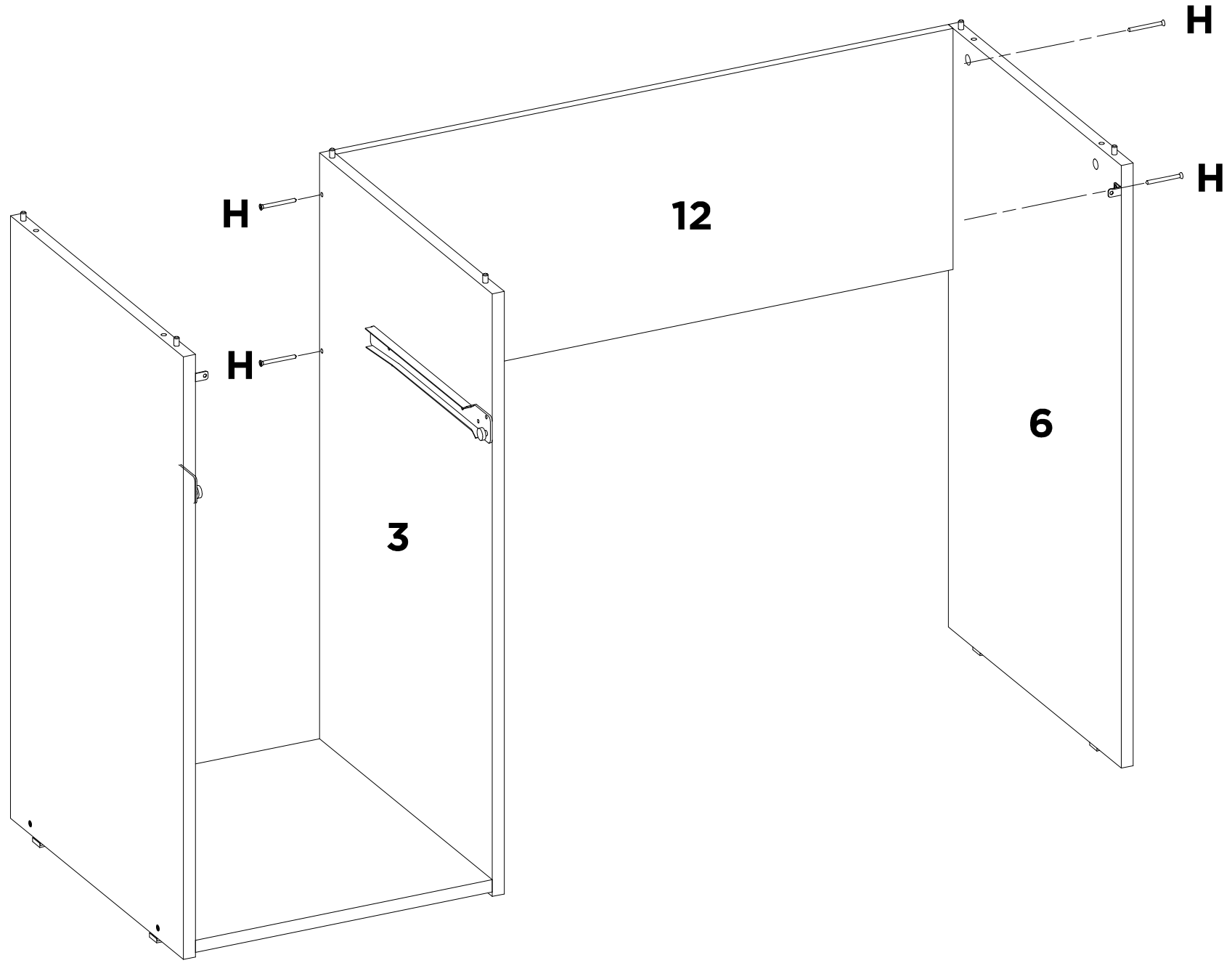

H	-	-	-	-	-	-	-
X4	-	-	-	-	-	-	-

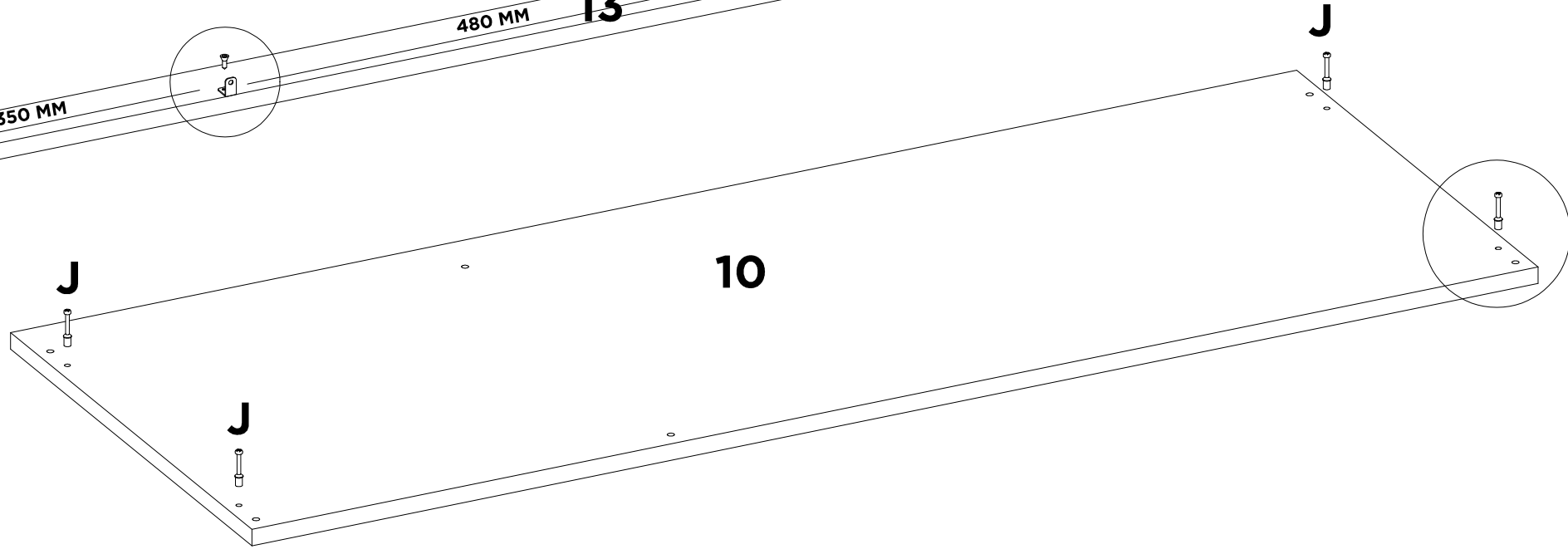
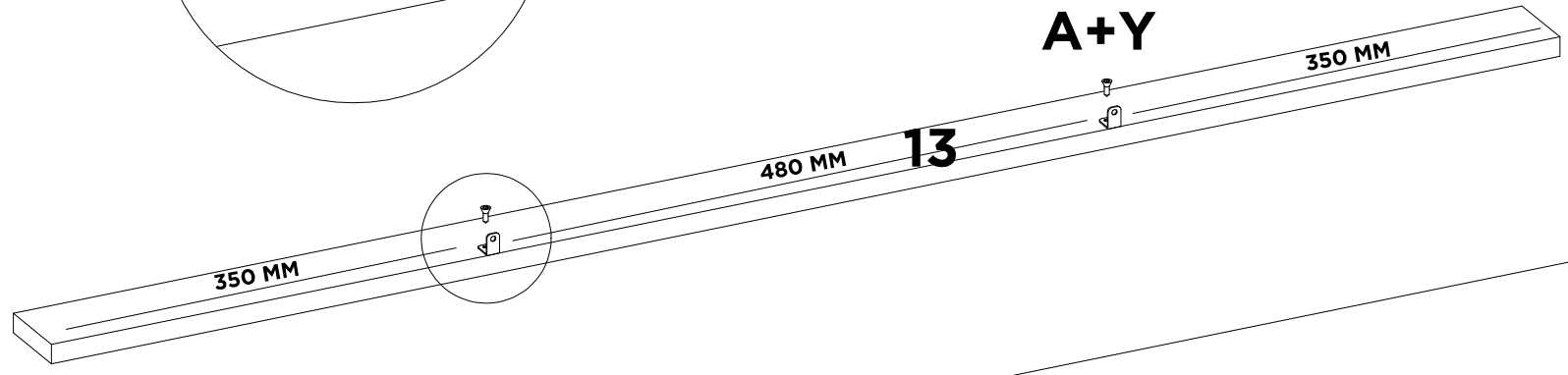
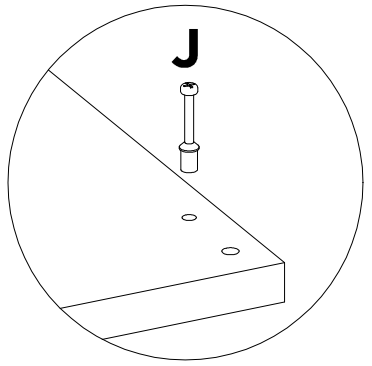
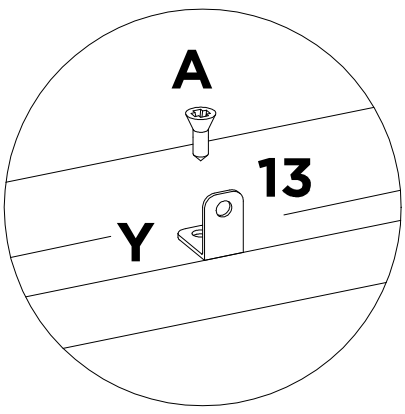

J	X4	Y	X2	A	X2	-	-	-	-	-	-
---	----	---	----	---	----	---	---	---	---	---	---

09

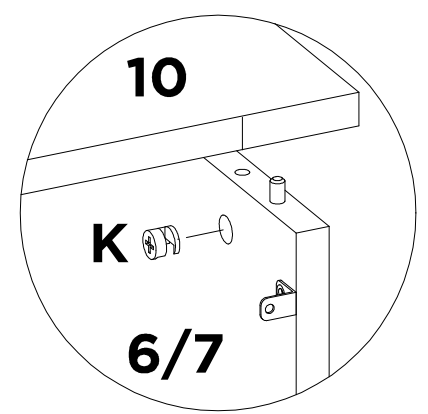
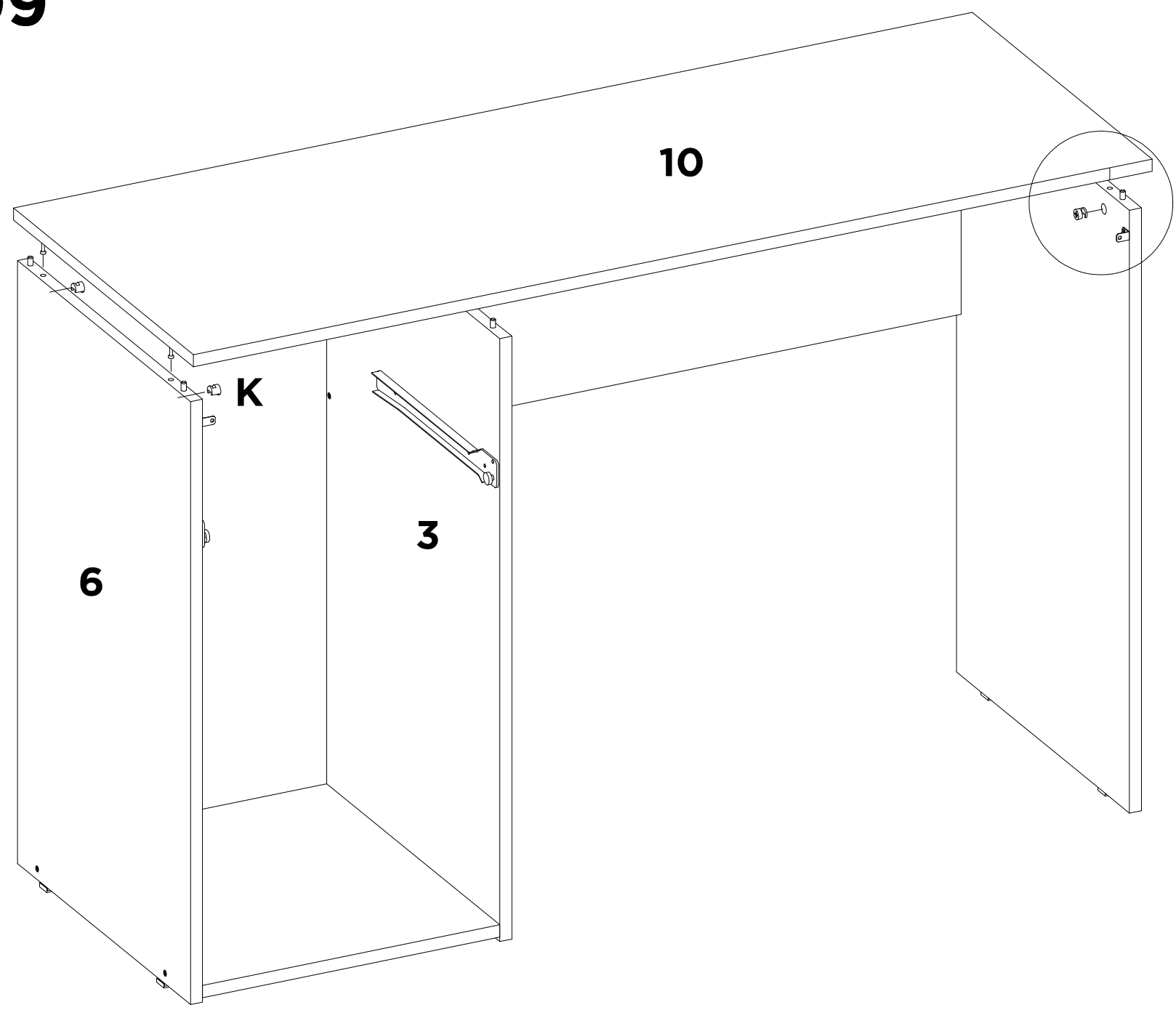

K	-	-	-	-	-	-	-
X4	-	-	-	-	-	-	-

10

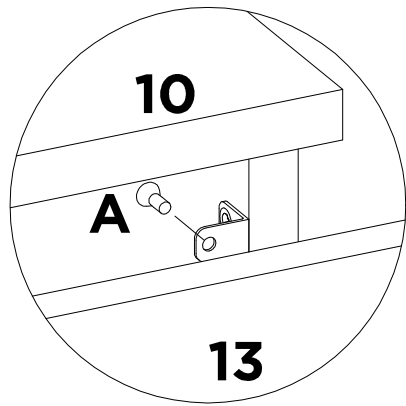
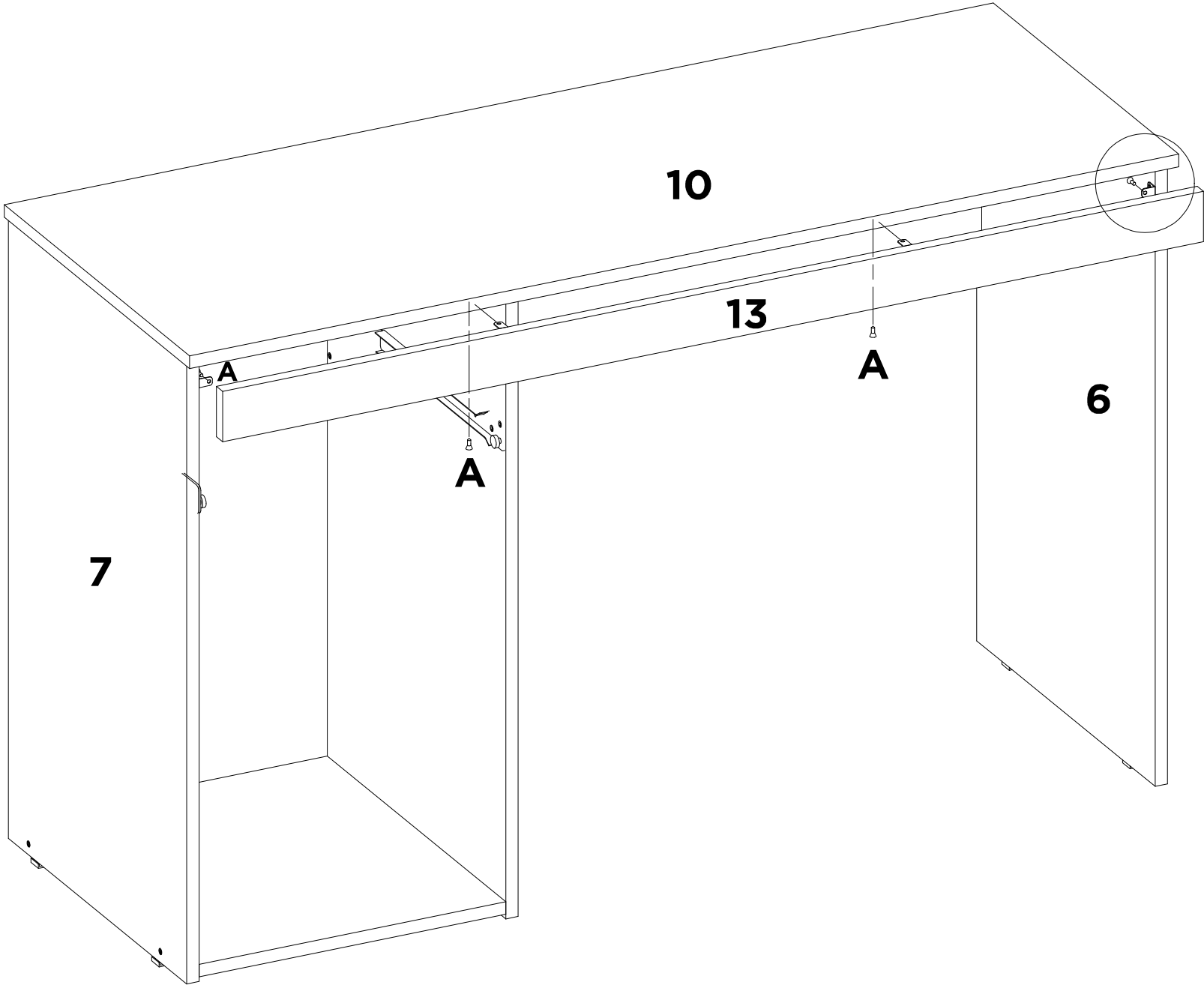

A	-	-	-	-	-	-	-
X4	-	-	-	-	-	-	-

11

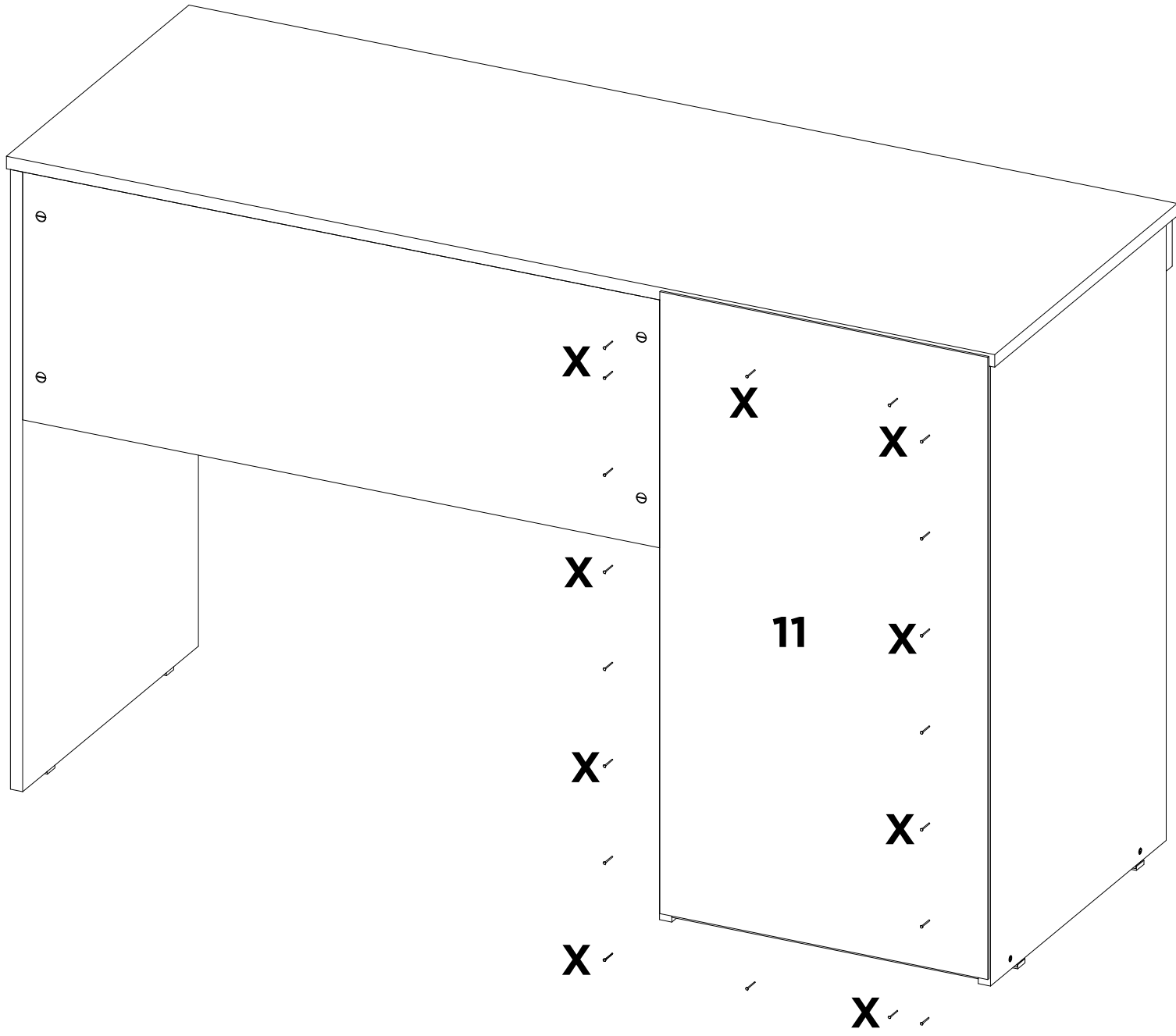

X
X25

-

-

-

-

-

-

-

12

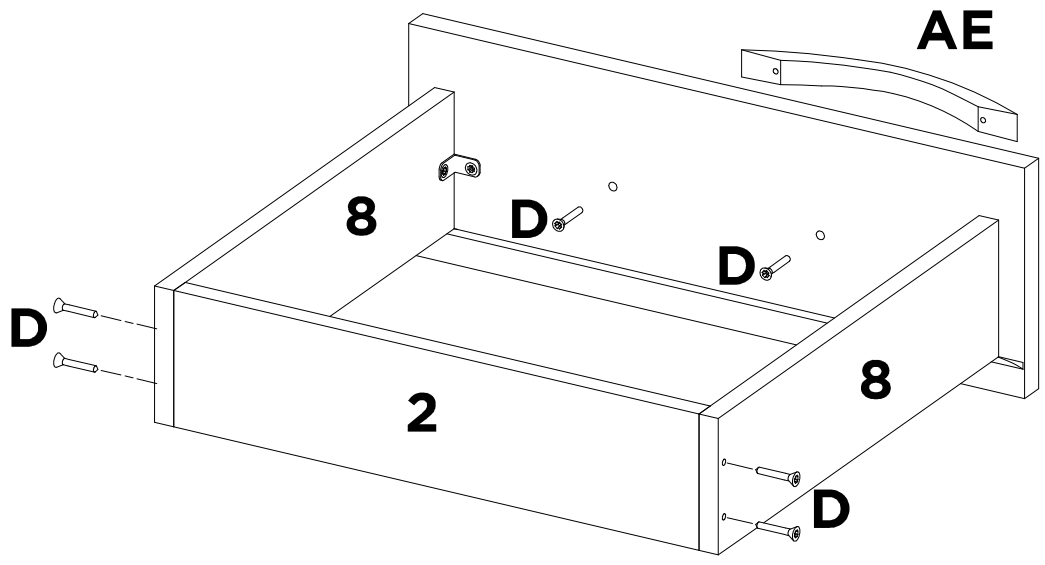
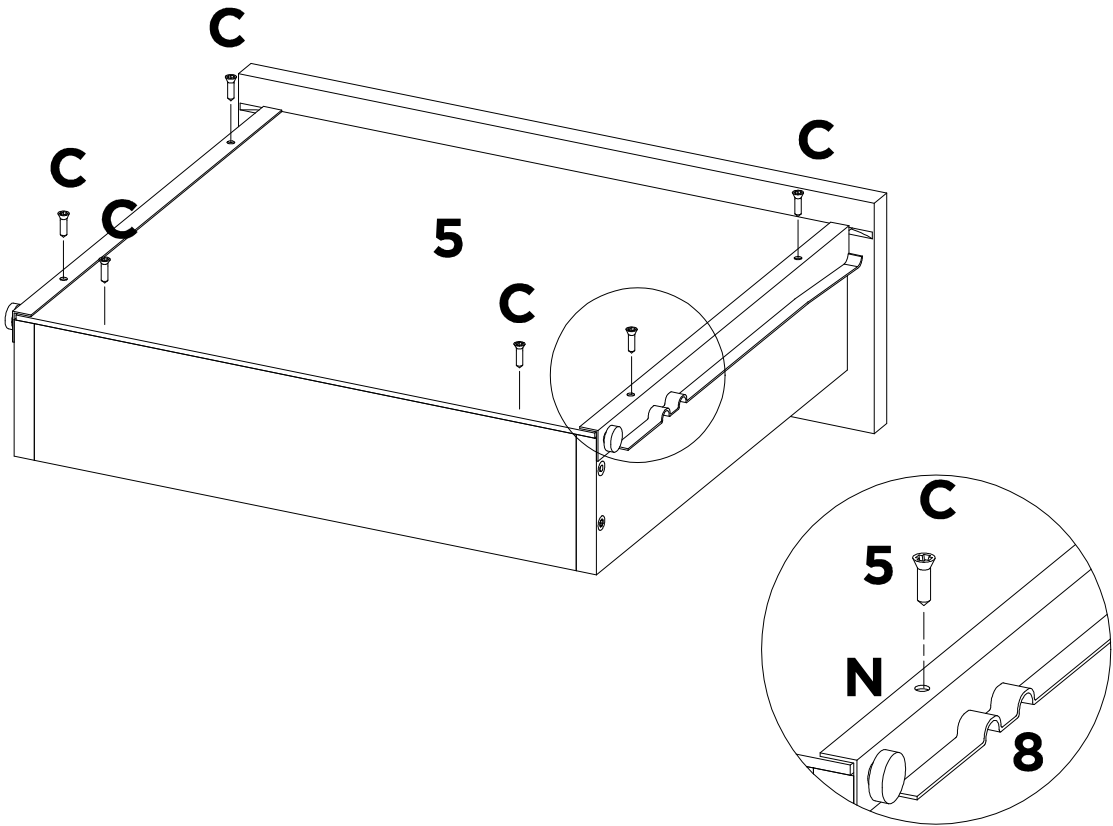
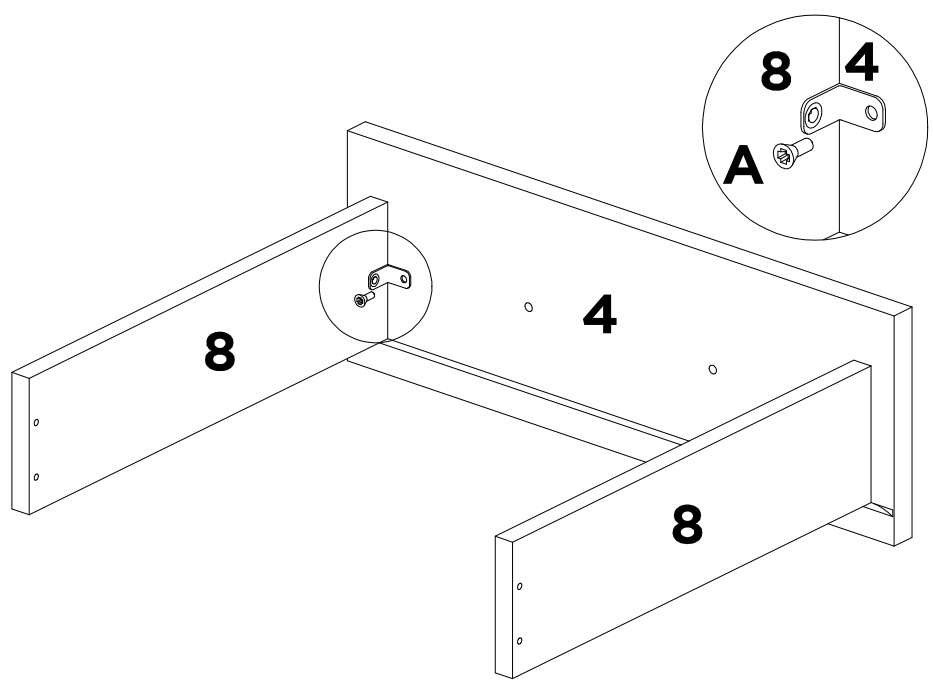
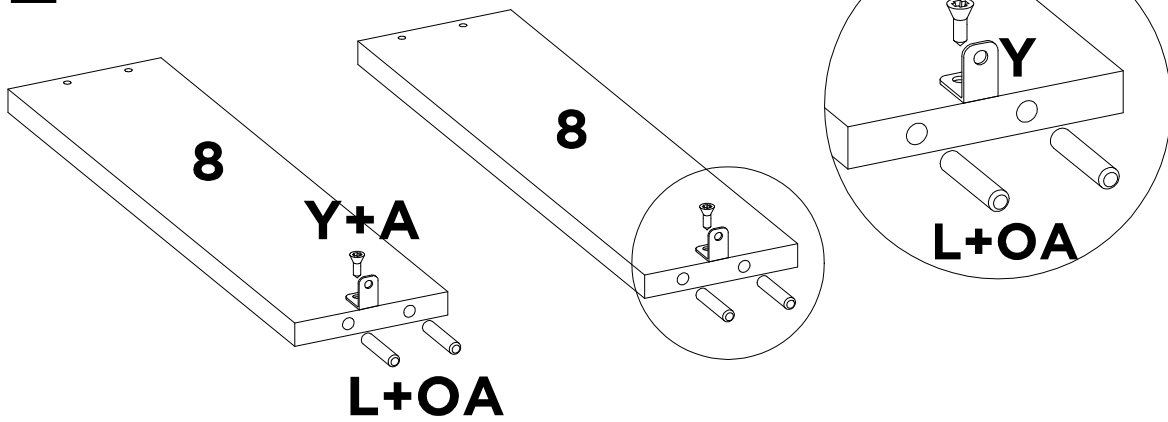

Y X2	A X4	AE X1	D X6	C X6	N X1	L X4	OA X1
-----------------------	-----------------------	------------------------	-----------------------	-----------------------	-----------------------	-----------------------	------------------------

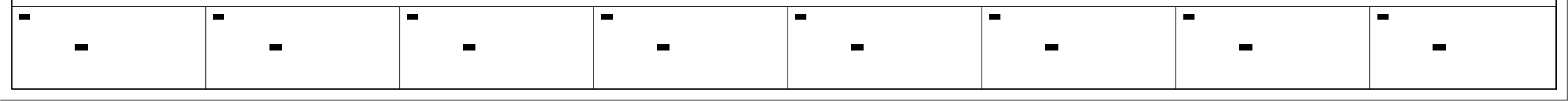
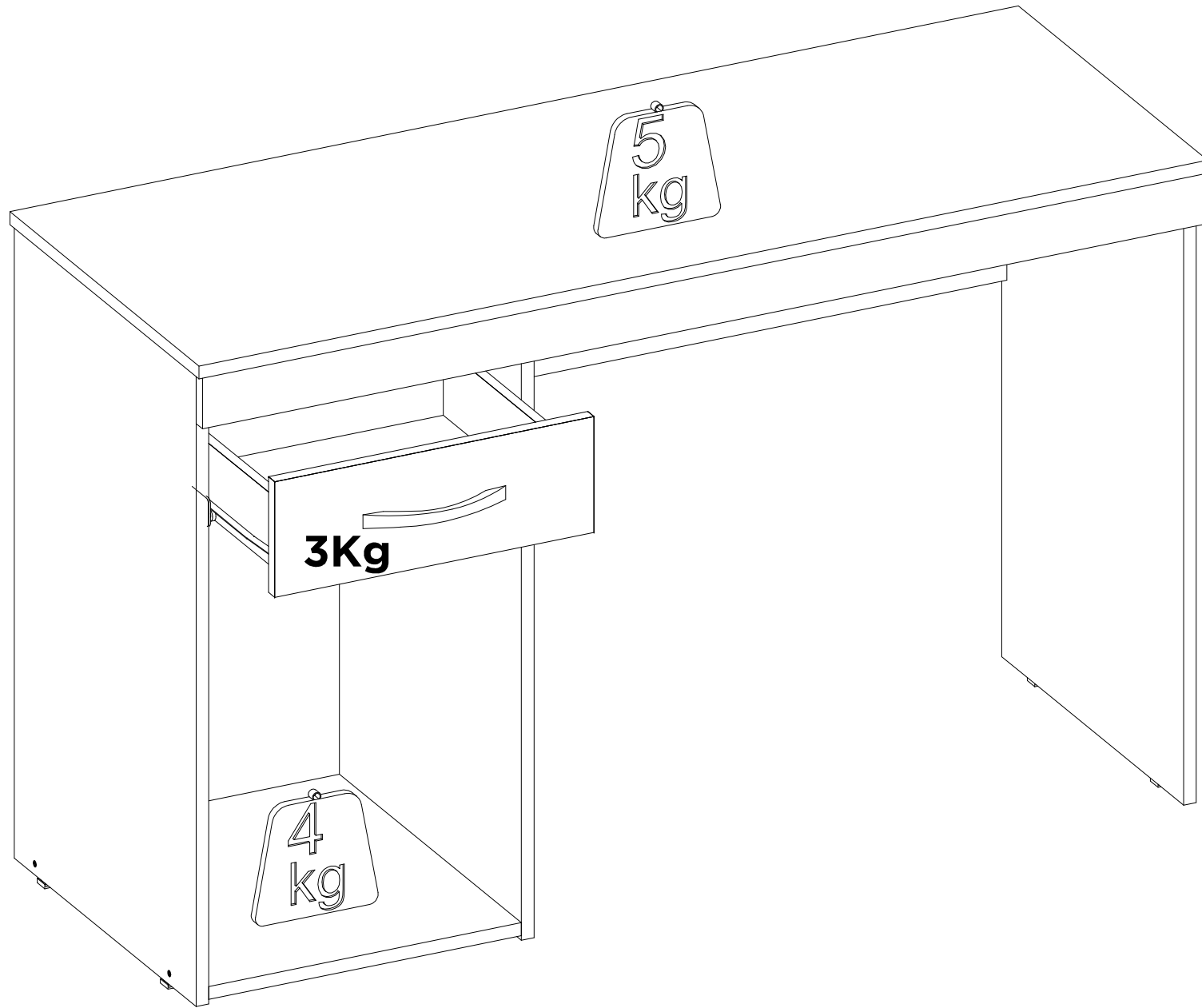

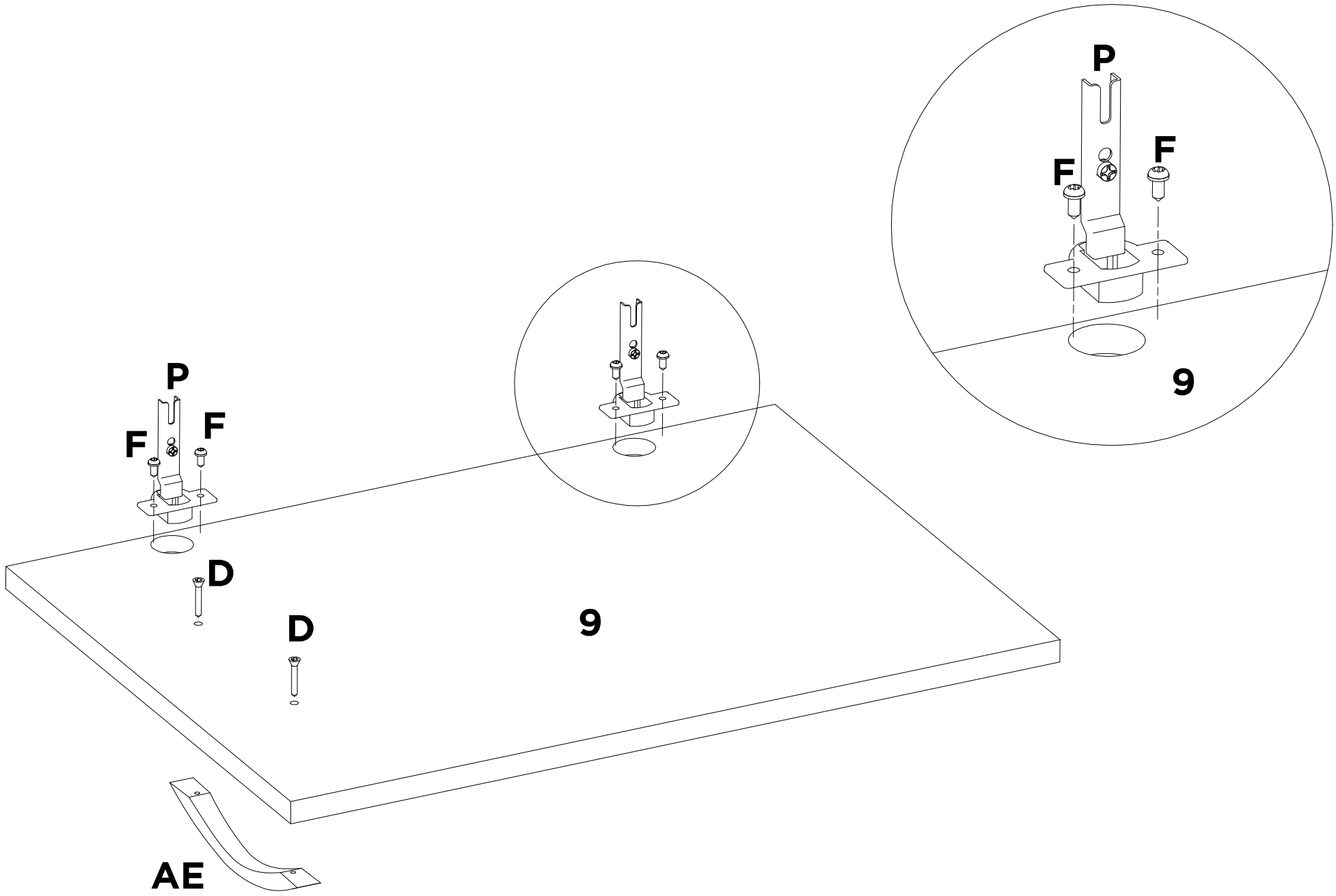

P	D	AE	F	-	-	-	-
X2	X2	X1	X4	-	-	-	-

