

ASSEMBLY INSTRUCTIONS MANUAL DE MONTAGEM / INSTRUCCIONES DE ARMADO

SPACE ONE GAMER TABLE AND OFFICE
MESA GAMER ESCRITORIO SPACE ONE
MESA GAMER Y OFICINA SPACE ONE

Reference
Referència
Referencia

220418

Revised
Revisão
Revisión

00



ENGLISH
PORTUGUÊS
ESPAÑOL

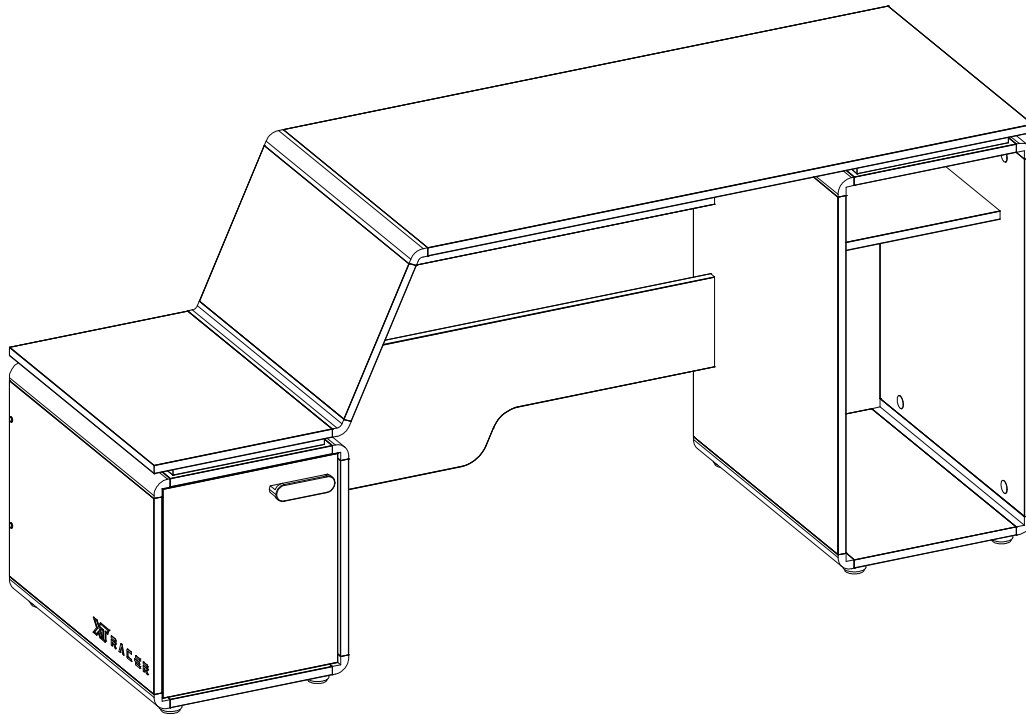

MAXIMUM RECOMMENDED WEIGHT
BEING THIS EVENLY DISTRIBUTED.

PESO MÁXIMO RECOMENDADO SENDO
ESTE DISTRIBUÍDO UNIFORMEMENTE.

PESO MÁXIMO RECOMENDADO SIENDO
ESTE UNIFORMEMENTE DISTRIBUIDO.

	LB	KG
–		
C	6	3
F	22	10
H	44	20

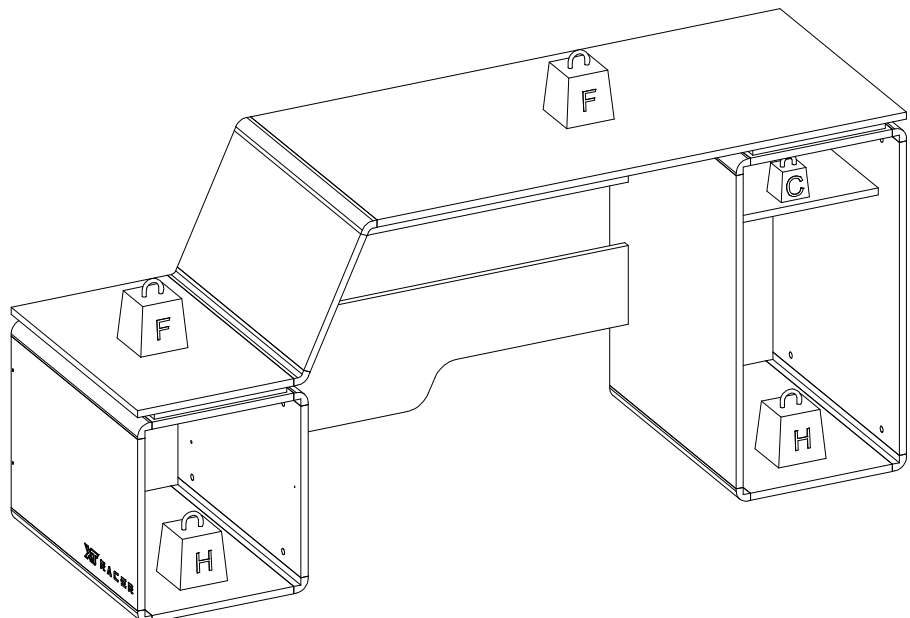

Nº	Measures_Inches	Medidas_cm	Qty./Qtd.
01	44 x 21 1/8 x 5/8	111.9 x 53.5 x 1.5	1
02	13 x 21 1/8 x 5/8	33.0 x 53.5 x 1.5	1
03	11 1/4 x 21 1/8 x 5/8	28.5 x 53.5 x 1.5	1
05	11 x 20 1/4 x 5/8	28.0 x 51.5 x 1.5	2
06	13 x 17 1/2 x 5/8	33.0 x 44.5 x 1.5	1
07	11 3/4 x 21 1/8 x 5/8	30.0 x 53.5 x 1.5	2
08	11 3/4 x 21 1/8 x 5/8	30.0 x 53.5 x 1.5	2
09	14 x 21 1/8 x 5/8	35.5 x 53.5 x 1.5	1
10	14 x 21 1/8 x 5/8	35.5 x 53.5 x 1.5	1
11	25 1/2 x 21 1/8 x 5/8	64.8 x 53.5 x 1.5	1
12	25 1/2 x 21 1/8 x 5/8	64.8 x 53.5 x 1.5	1
13	13 x 15 1/8 x 5/8	33.0 x 38.5 x 1.5	1
14	35 5/8 x 9 7/8 x 5/8	90.5 x 25.0 x 1.5	1
15	13 x 2 3/4 x 5/8	33.0 x 7.0 x 1.5	1
16	14 7/8 x 12 3/4 x 5/8	37.9 x 32.4 x 1.5	1
17	34 7/8 x 6 1/8 x 5/8	88.6 x 15.5 x 1.5	1
60	21 1/8 x 1 1/8 x 1 1/8	53.5 x 3.0 x 3.0	8
61	21 1/8 x 1 3/8 x 1 1/8	53.5 x 3.5 x 2.8	2

PARTS IDENTIFICATION IDENTIFICAÇÃO DAS PEÇAS / IDENTIFICACIÓN DE LAS PIEZAS

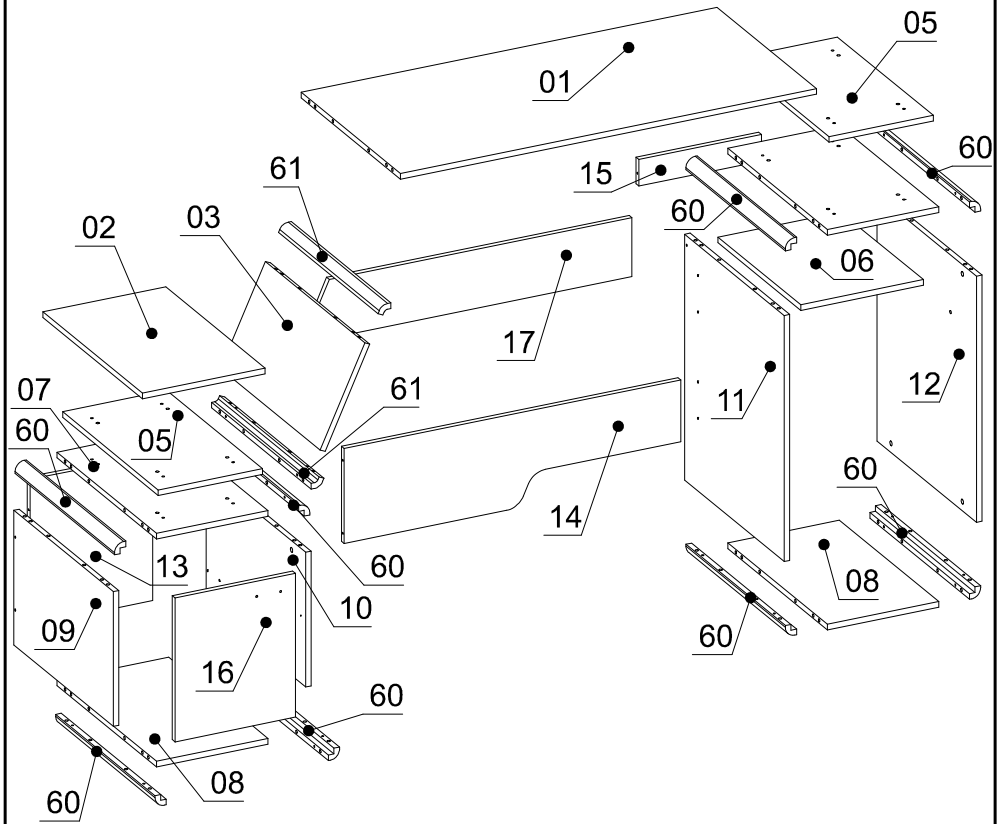

YOU WILL NEED / VOCÊ VAI PRECISAR DE / USTED NECESITARÁ

Tools not supplied / Ferramentas não fornecidas / Herramientas no incluidas

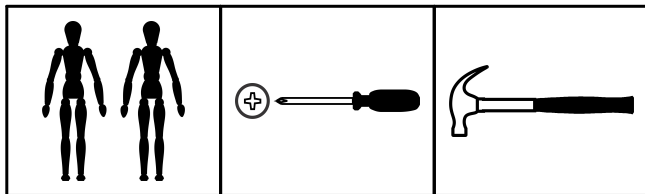

2 People
2 Pessoas
2 Personas

Screwdriver Phillips
Chave Phillips
Destornillador cruz

Hammer
Martelo
Martillo











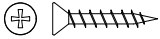





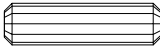

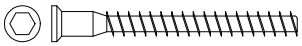
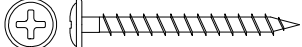
The separation of the accessories before you start the assembly will facilitate the same. In case of doubt on the size of the screws and bolts, use the ruler to bottom of page 3.

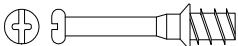
A separação dos acessórios antes de iniciar a montagem facilitará a mesma. Em caso de dúvida no tamanho dos parafusos e cavilhas, utilize a régua ao final da página 3.

La separación de los accesorios antes de comenzar el armado facilitará el mismo. En caso de duda sobre el tamaño de los tornillos y taquetes, utilice la regla al pie de página 3.

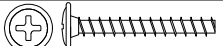
IDENTIFICATION OF ACCESSORIES IDENTIFICAÇÃO DOS ACESSÓRIOS/ IDENTIFICACIÓN DE ACCESORIOS

A1		Glue / Cola / Pegamento	13 g	2
A8		Flat head screw / Parafuso chato / Tornillo de cabeza plana	3,5x20 mm	8
A26		Handle / Puxador Asti / Tirador	64mm	1
B5		Metalic angle plates / Cantoneira de metal / Suporte de metal	46 mm	2
B8		Shelf bracket / Suporte de prateleira / Suporte de repisa	10x15 mm	1
C15		Wooden dowel / Cavilha / Taquete	8x40 mm	8
D5		Hinge shim / Calço dobradiça / Bisagra de calce	-	2
D6		Metal hinge super hight / Dobradiça super alta / Bisagra alta	26 mm	2
E		Wooden dowel / Cavilha / Taquete	8x30 mm	80
E3		Shelf bracket / Suporte de prateleira / Suporte de repisa	8x7 mm	4
G		Structural screw / Parafuso estrutural / Tornillo estructural	5,0x50 mm	12
G3		Flanged head screw / Parafuso flangeado / Tornillo de cabeza flangeada	5,0x40 mm	8
H		Allen key / Chave allen / Liave allen	3 mm	1
I		Structural screw cover/Tampa parafuso estrutural/Tapa tornillo estructural	-	12
J		Simple minifix screw / Haste minifix simples / Tornillo minifix simple	-	40
L		Drum lock / Tambor minifix / Tambor minifix	12 mm	40
L4		Plastic foot / Sapata / Pie plástico	38x17 mm	8
M		Bore patch adhesive / Tapa furo adesivo / Tapones adhesivo	-	20
S		Pan head screw / Parafuso panela / Tornillo de pan	3,5x14 mm	19
T		Flanged head screw / Parafuso flangeado / Tornillo de cabeza flangeada	3,5x25 mm	2
Y18		Zamac bracket / Cantoneira zamac / Suporte de zamac	13x13 mm	1



03

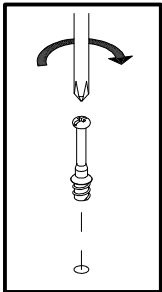
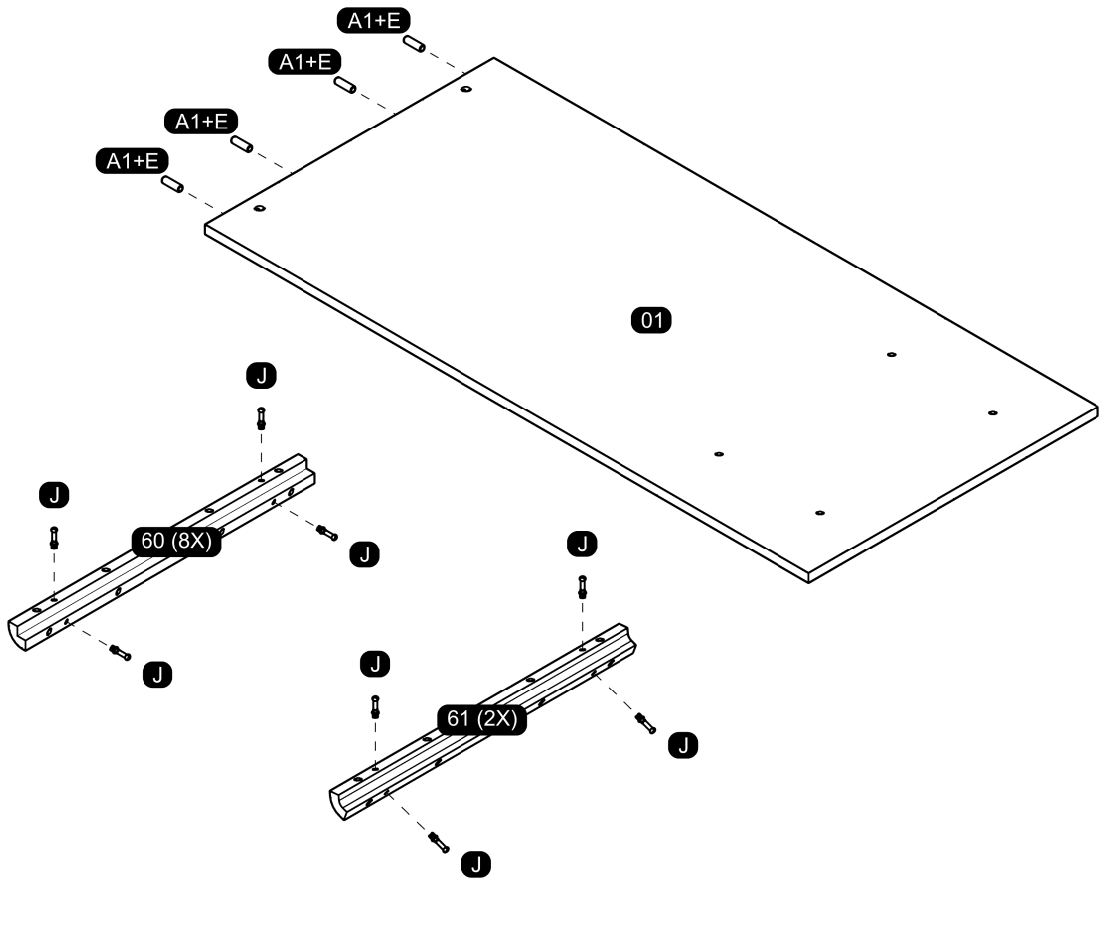
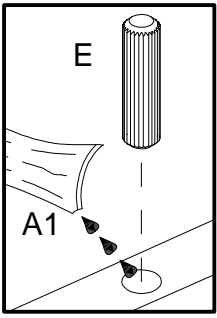

04

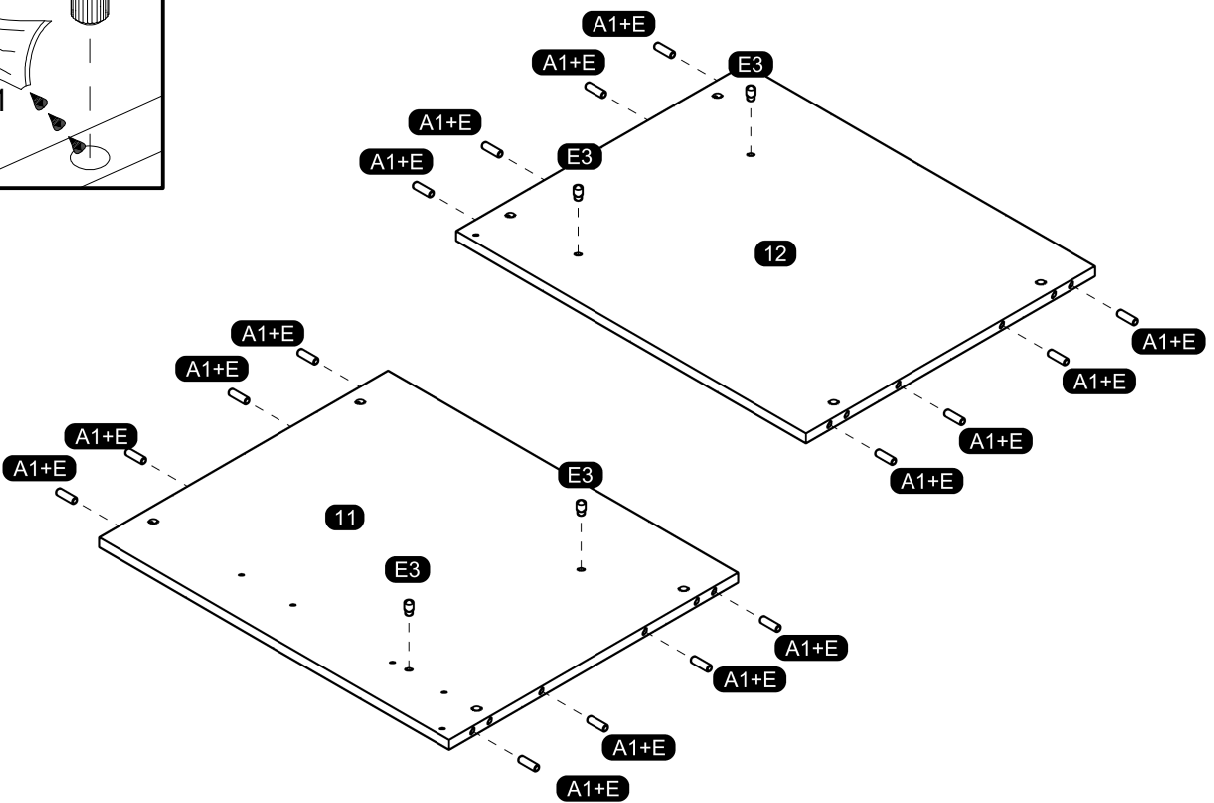
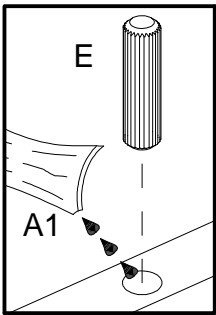

05

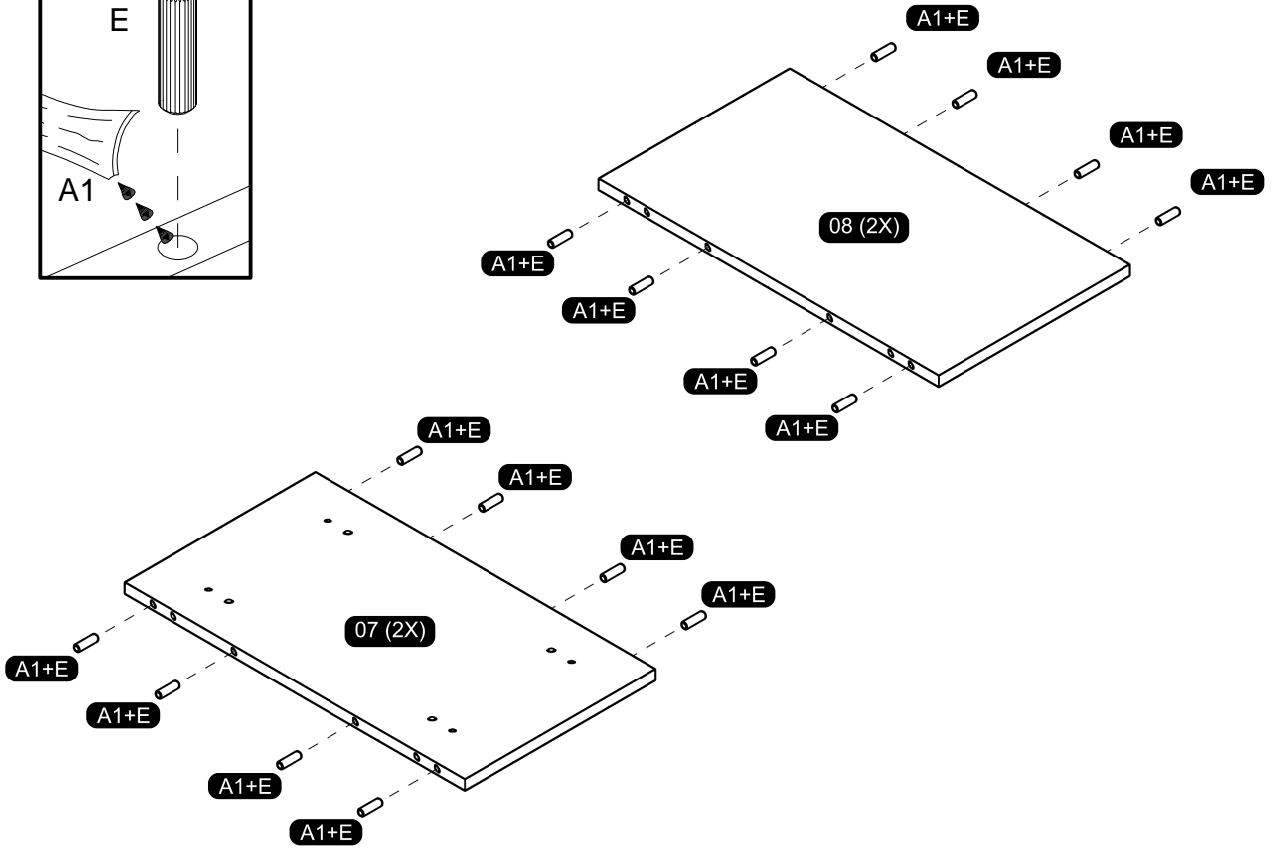
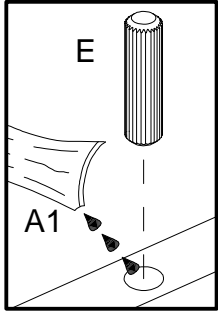

06

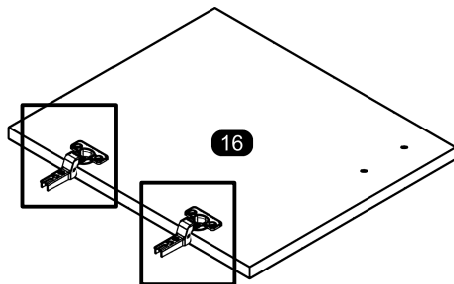
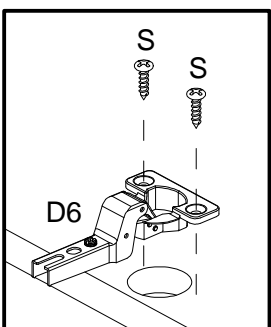
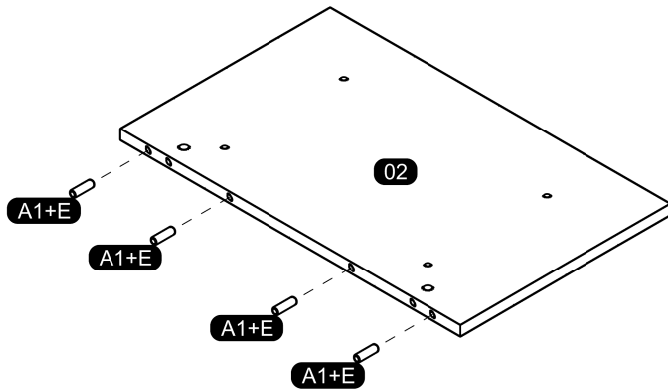
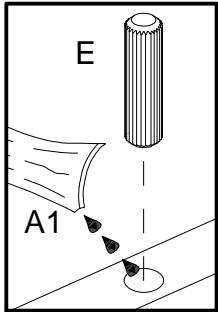

ASSEMBLY
MONTAGEM / ARMADO

07

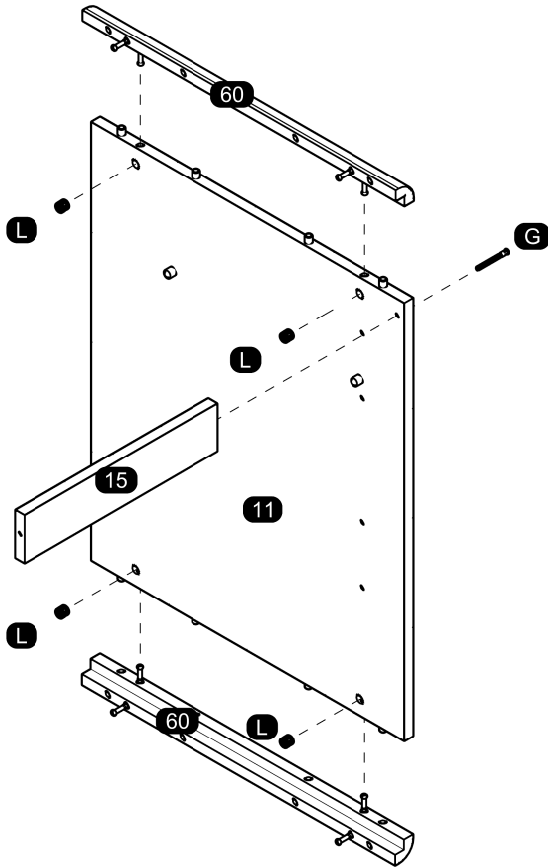
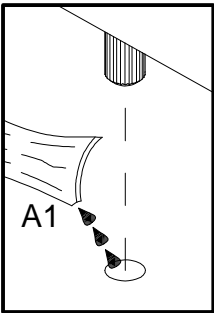
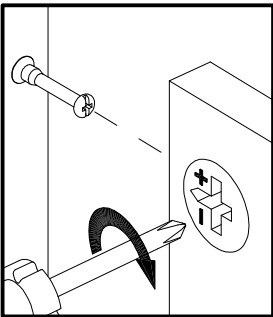

08

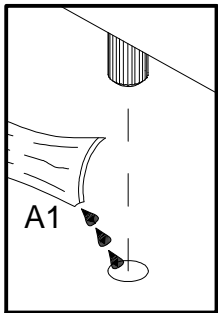
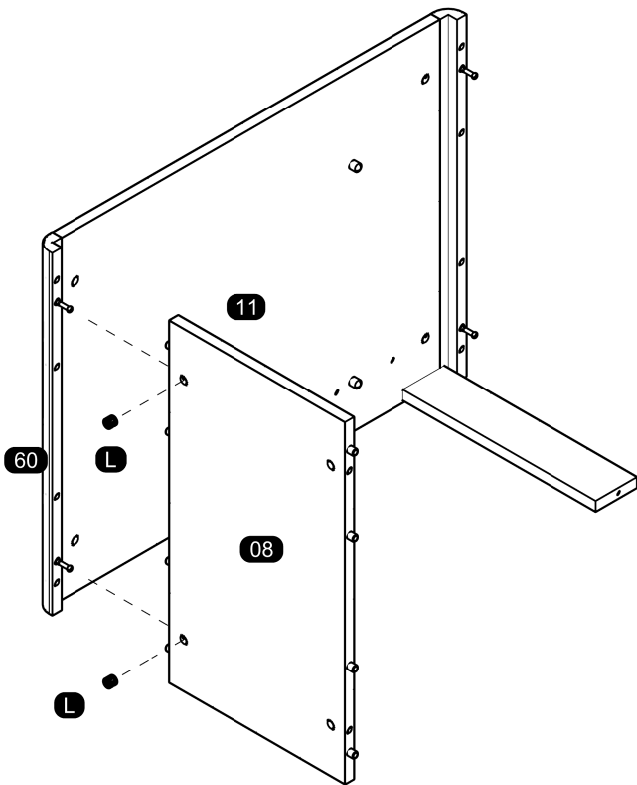

09

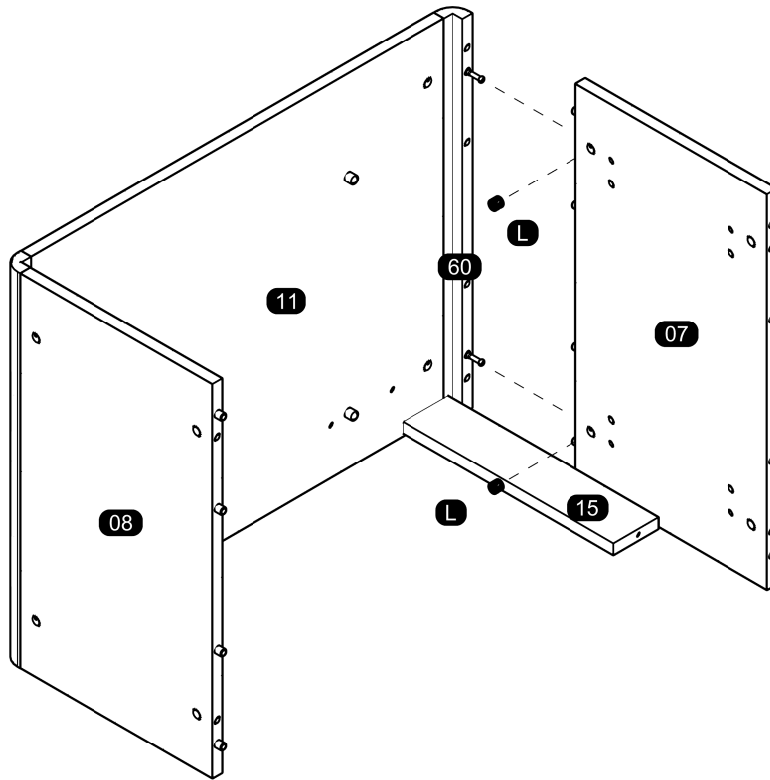
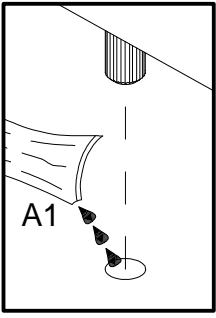

10

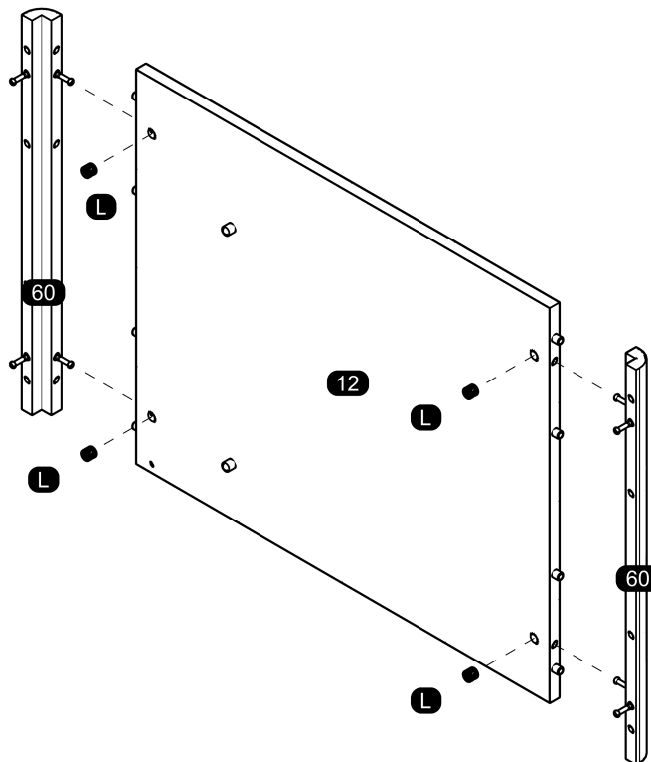
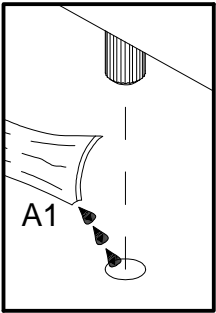

11

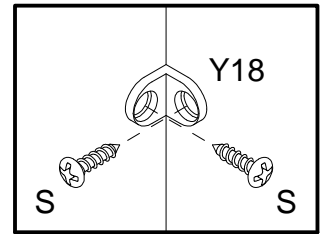
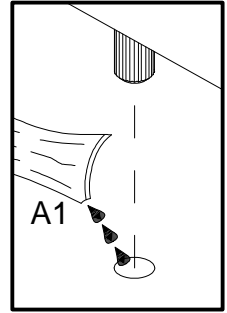
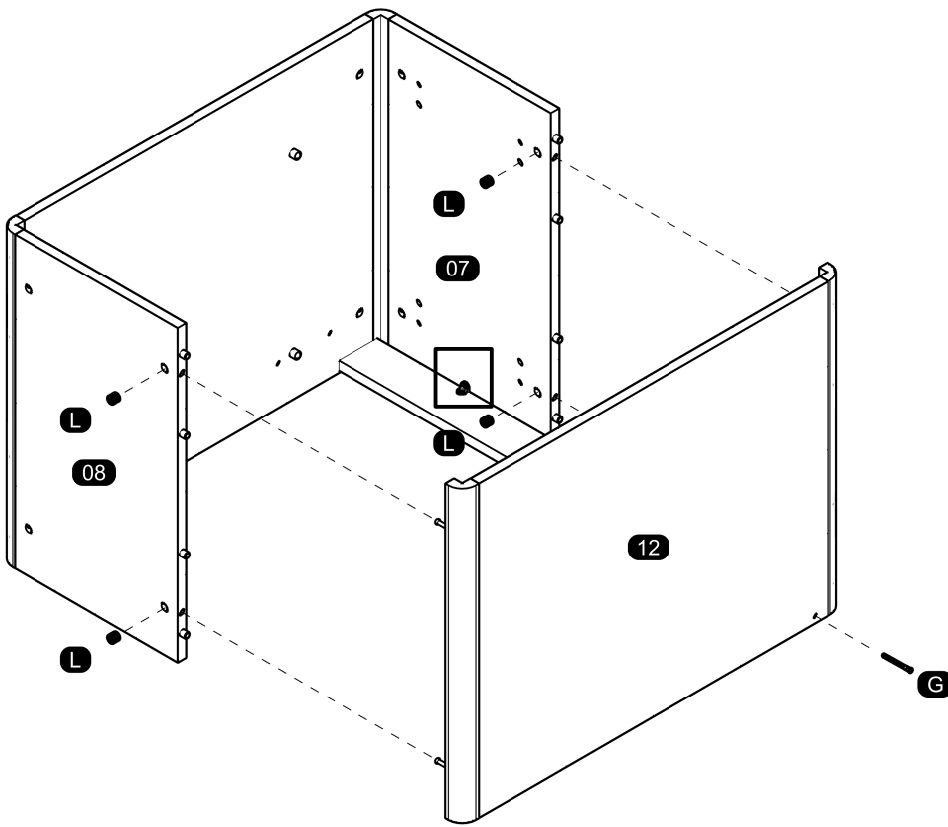

12

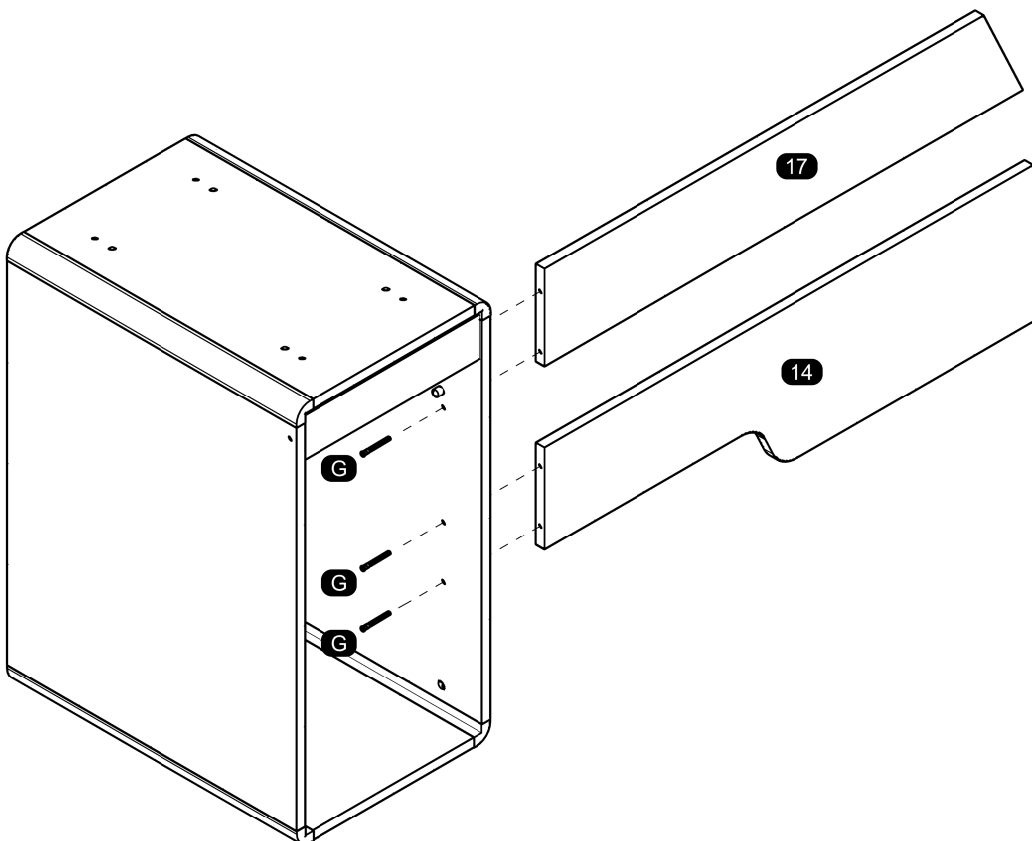

13

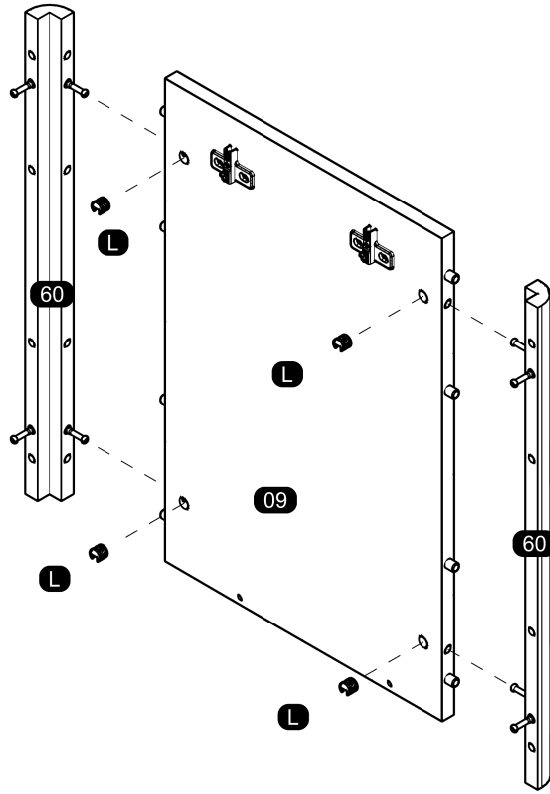
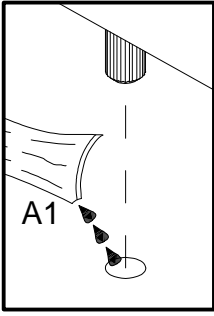

14

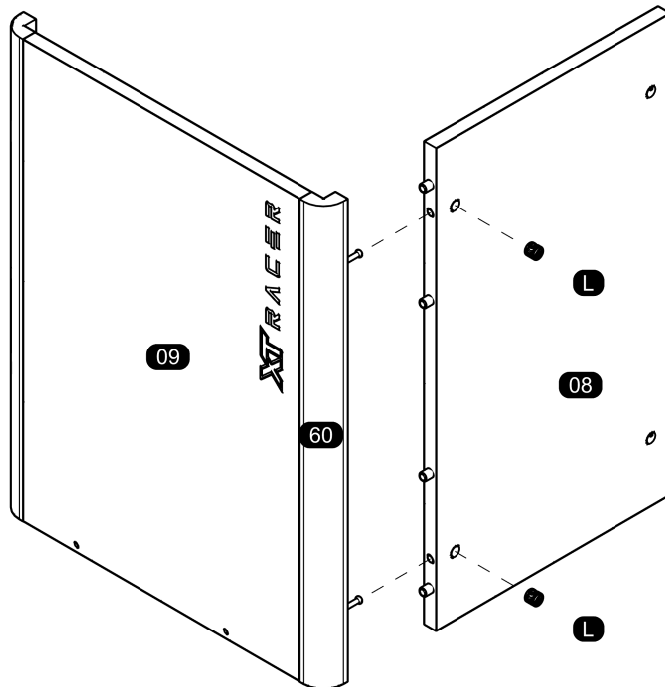
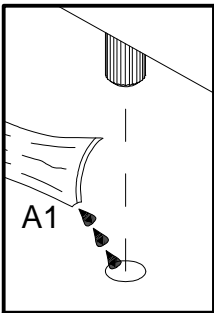

15

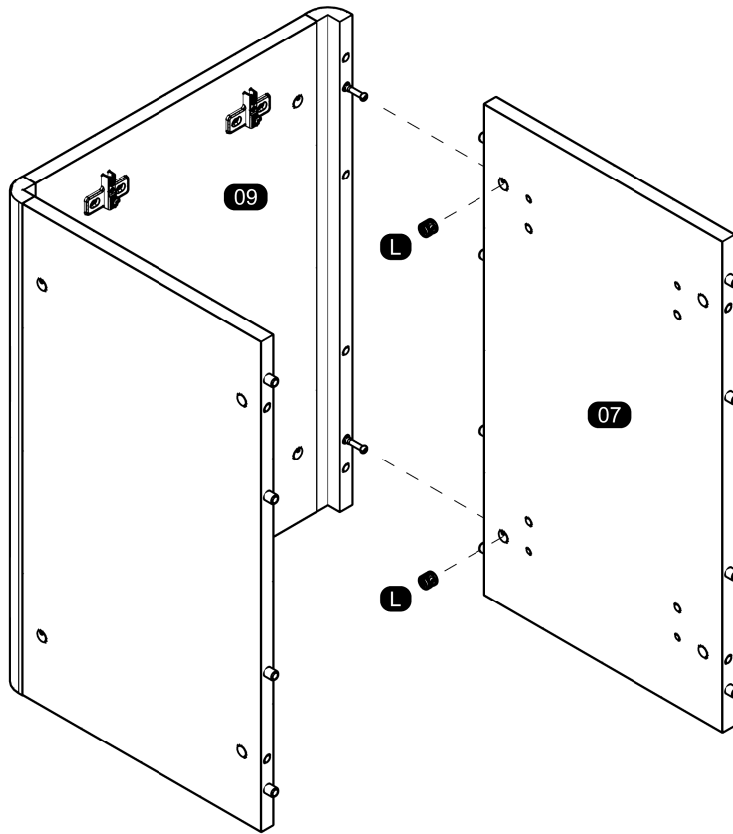
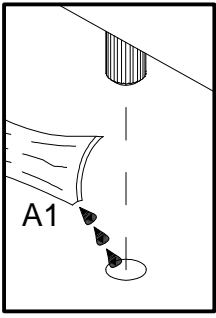

16

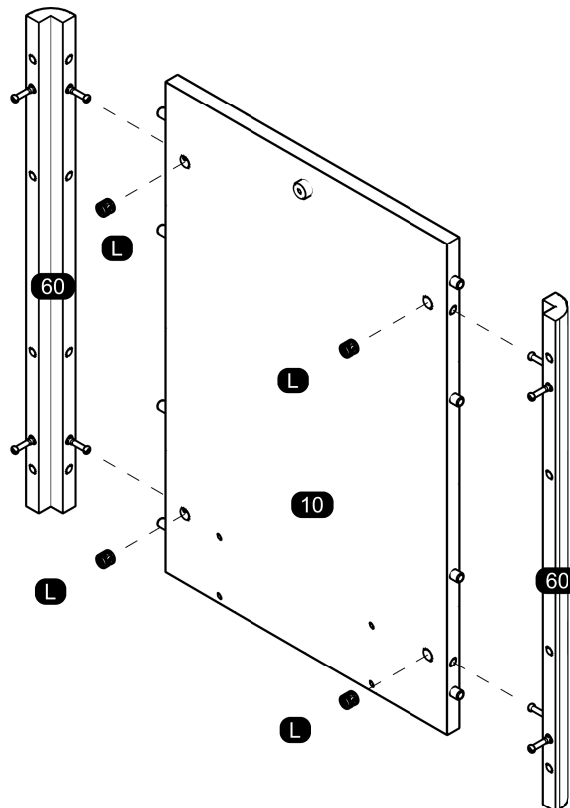
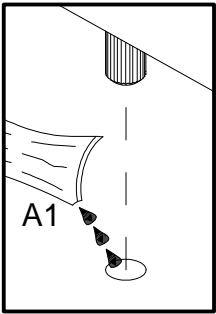

17

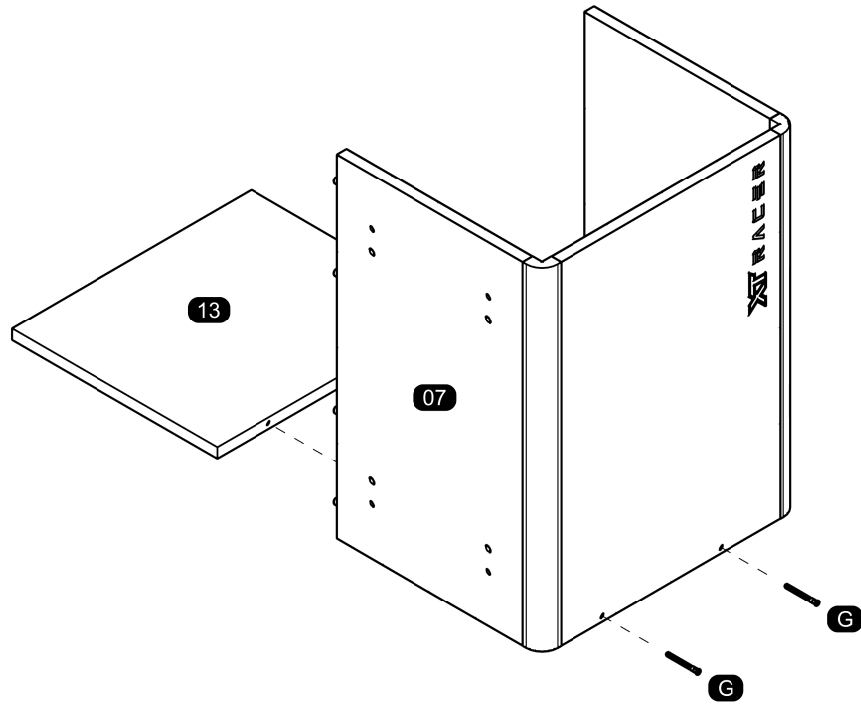

18

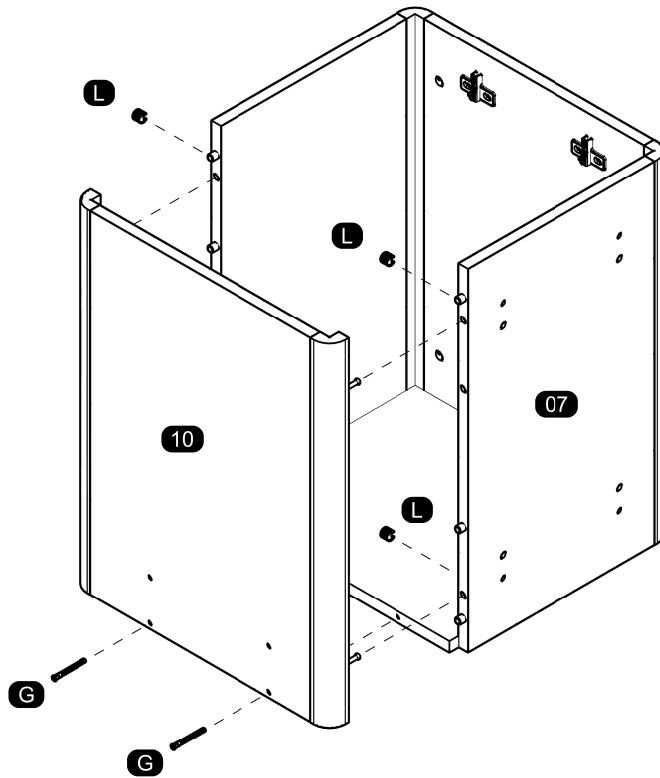
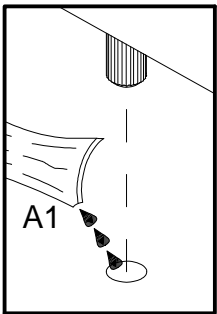

19

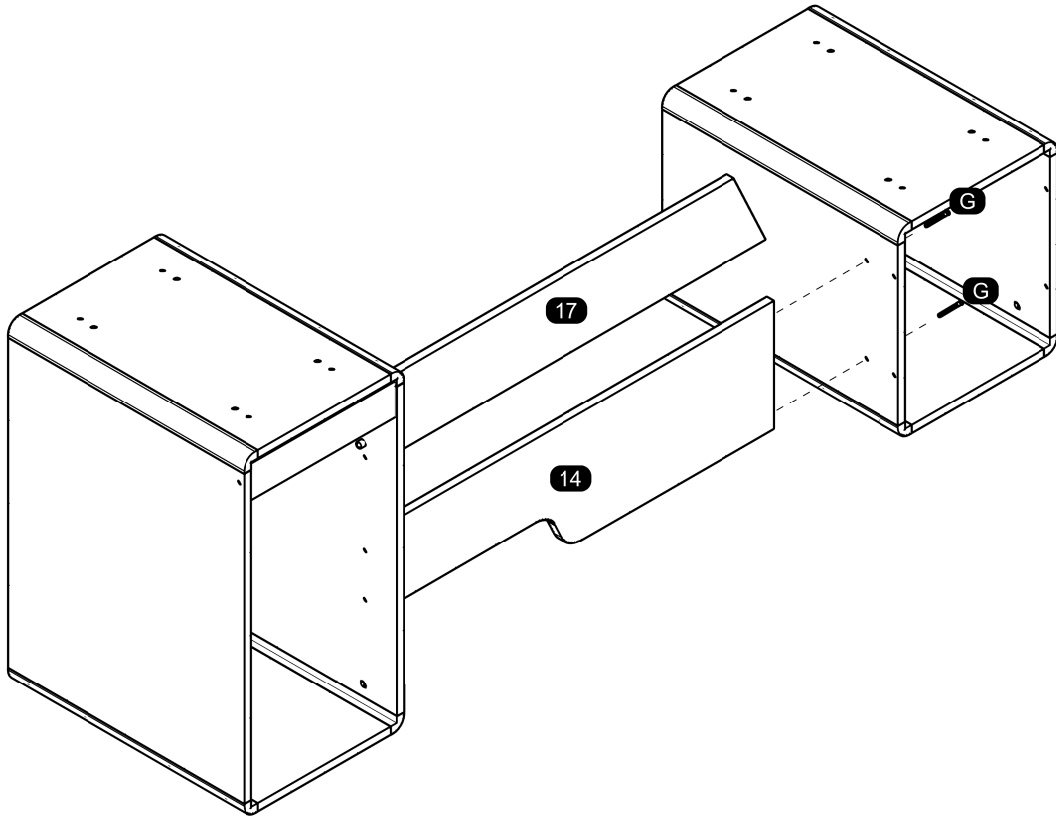

20

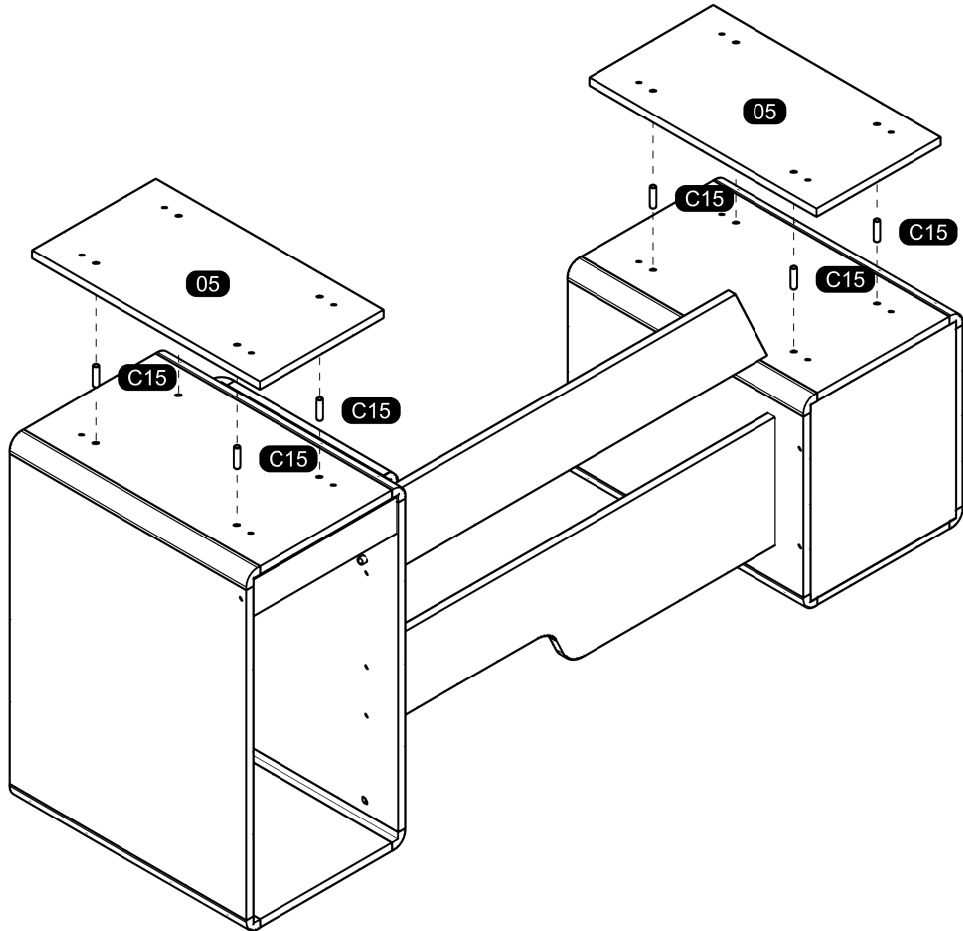

21

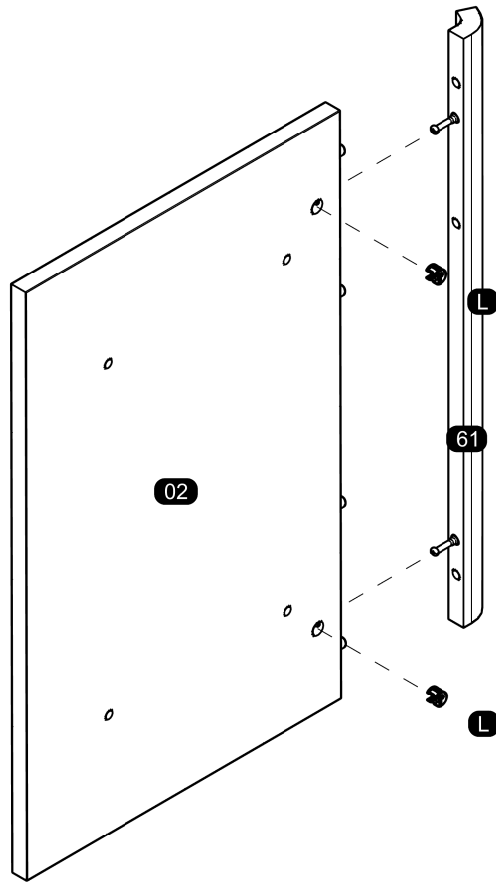
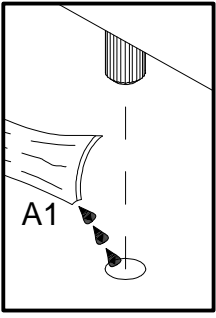

22

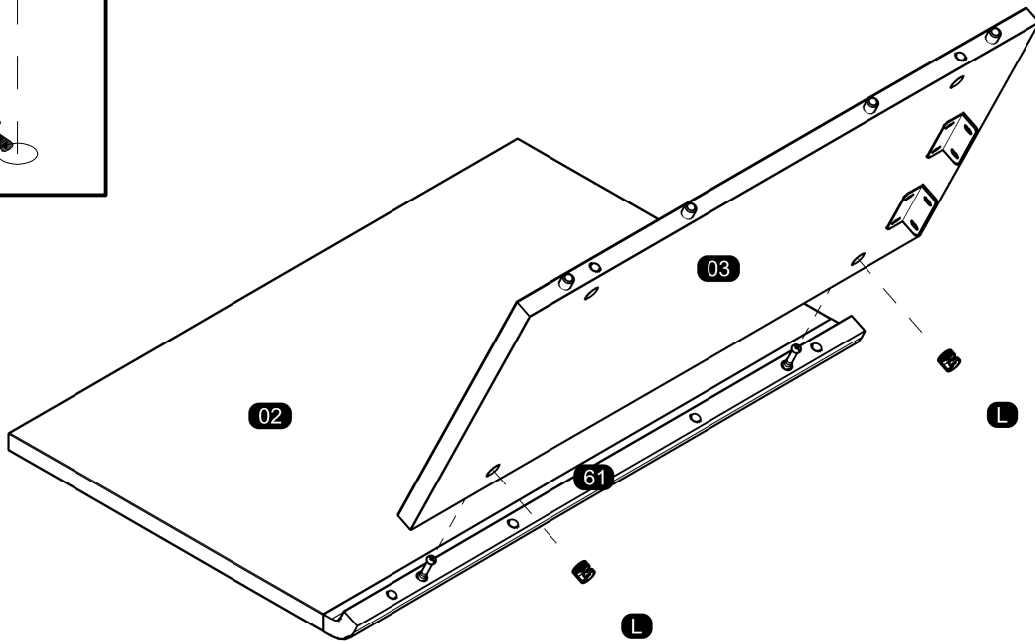
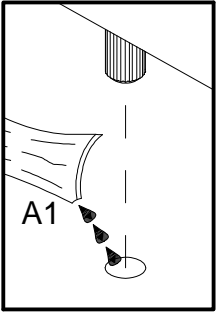

23

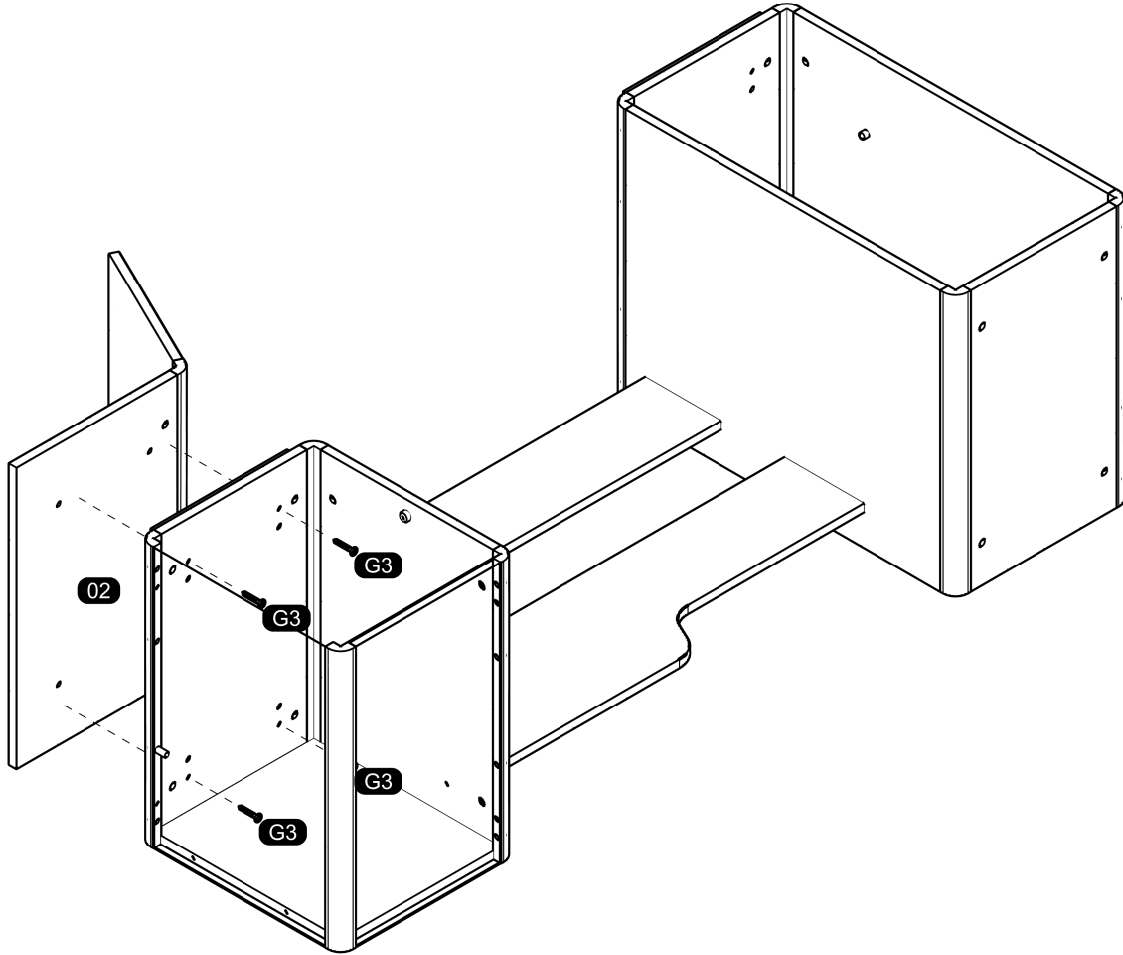

24

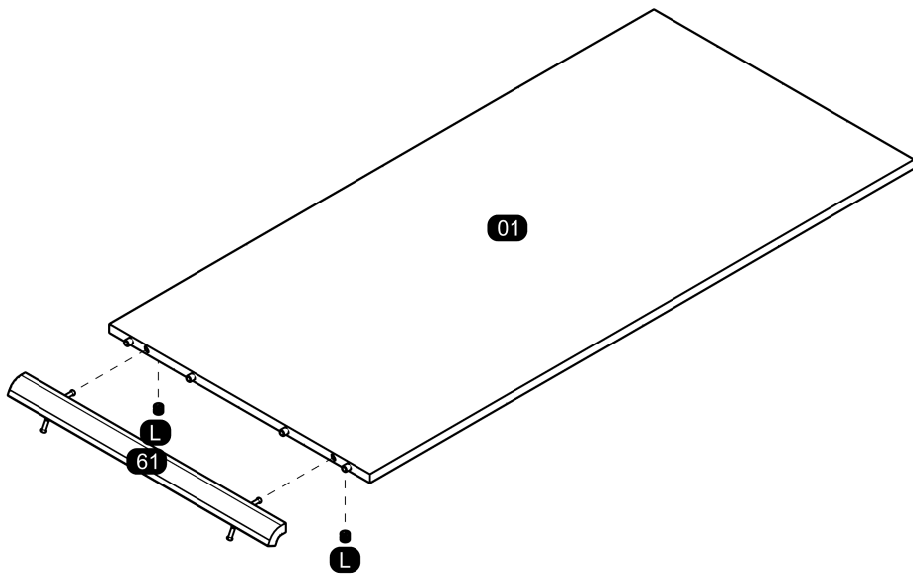

25

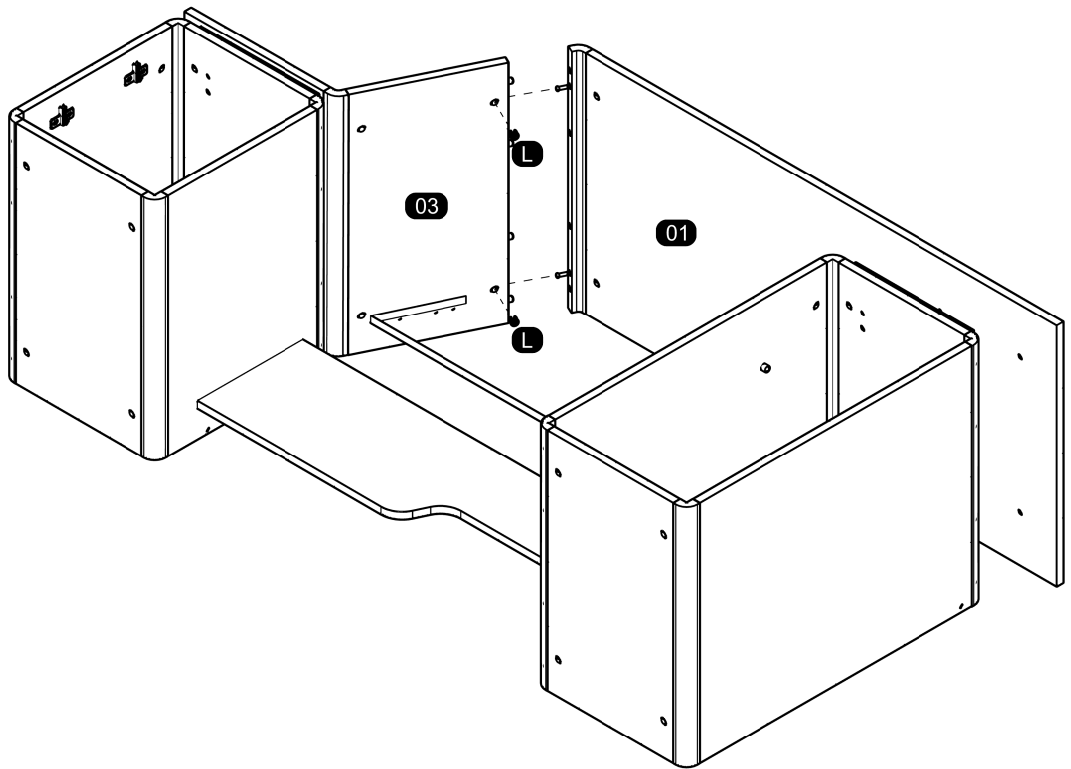
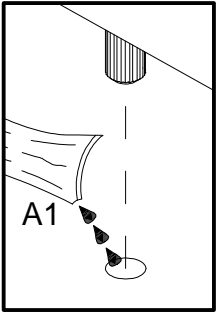

26

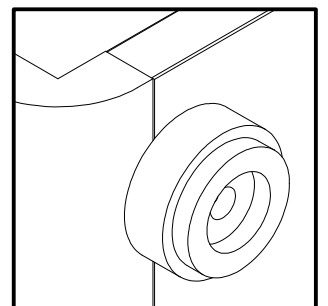
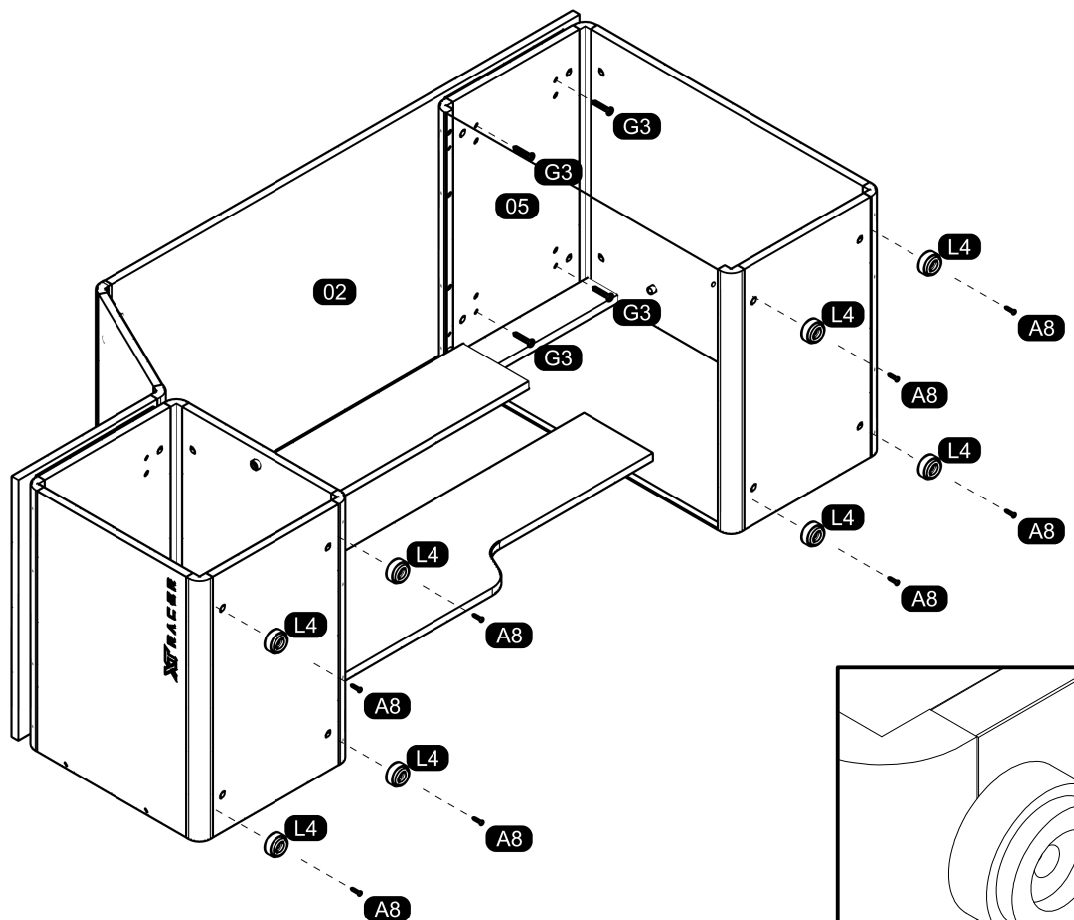

27

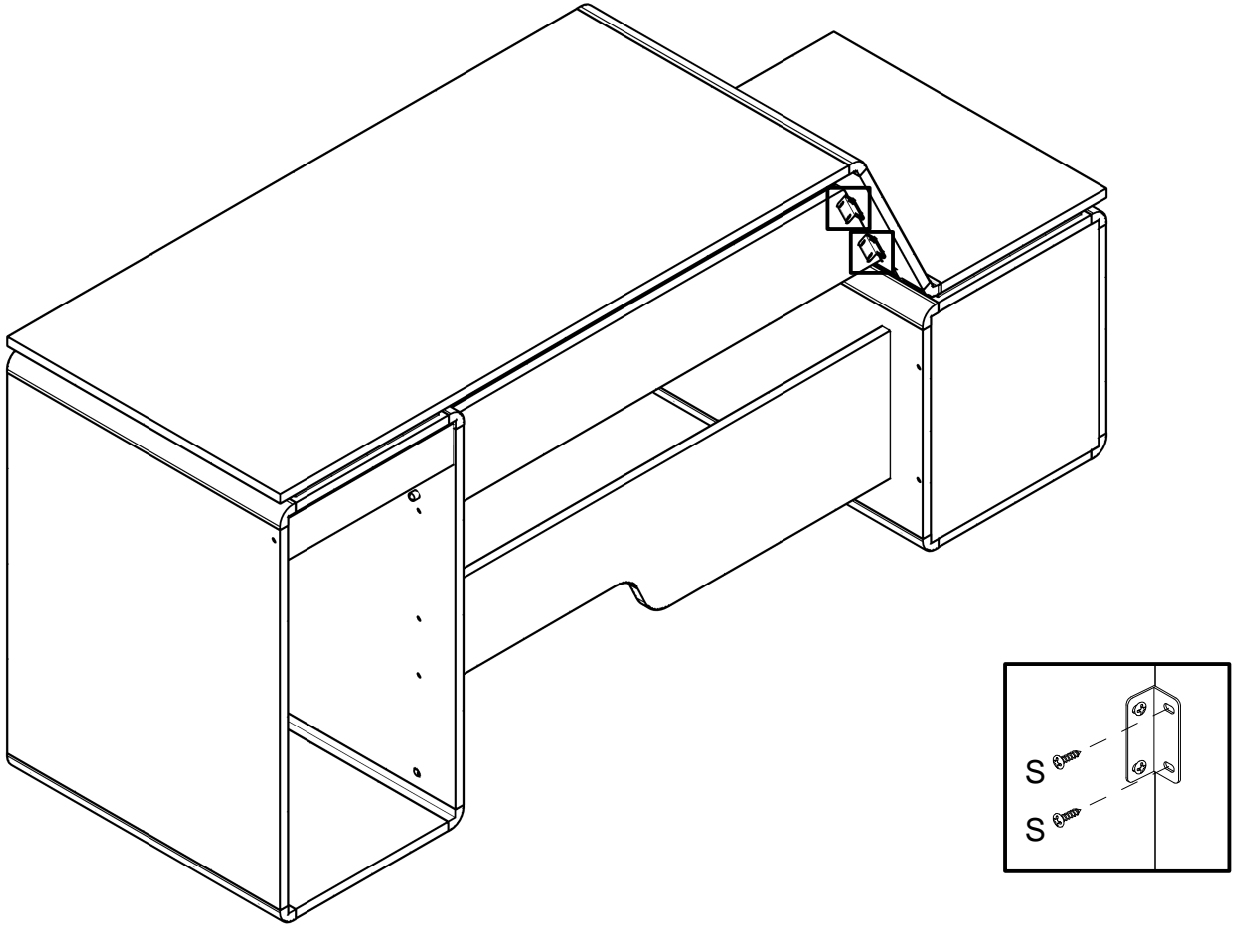

28

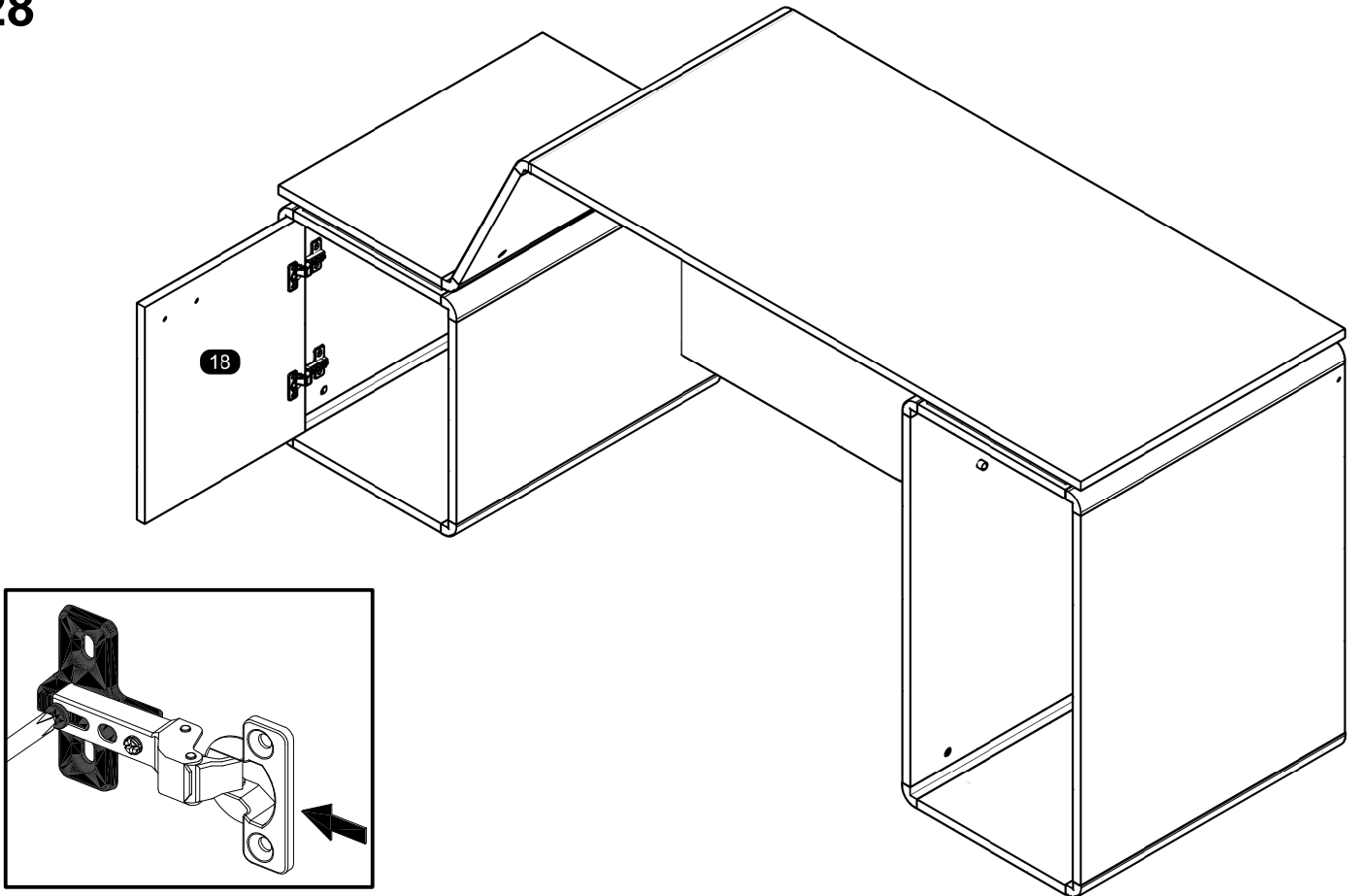

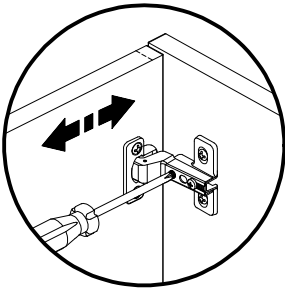
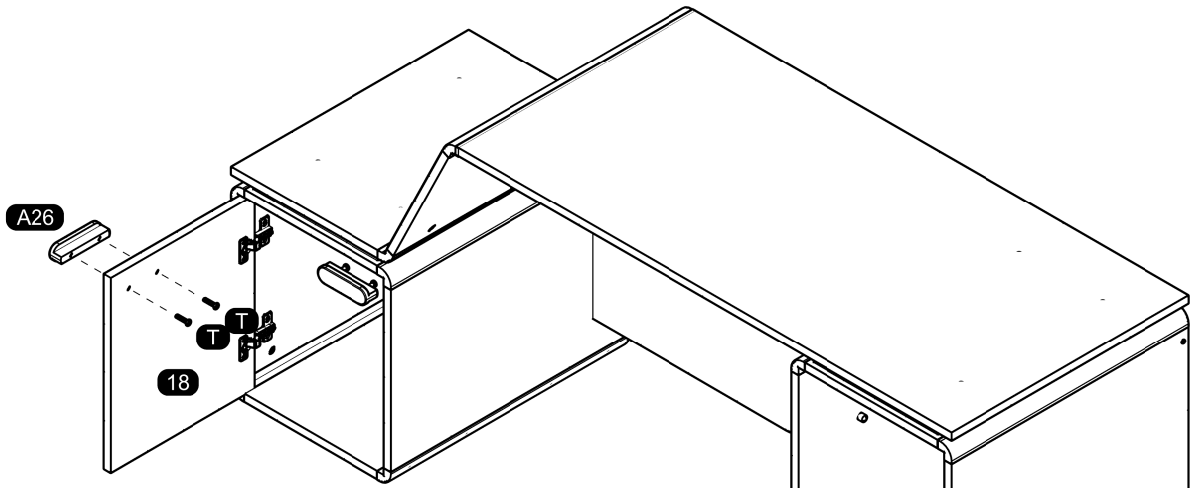

Horizontal Adjustment
Regulagem Horizontal
Ajuste Horizontal

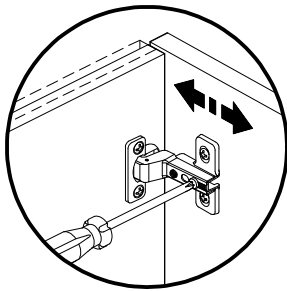

Depth Adjustment
Regulagem Profundidade
Ajuste Profundidade

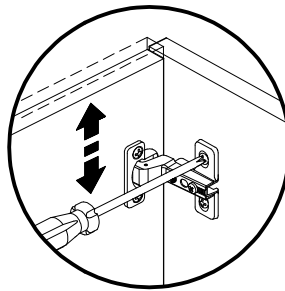

Vertical Adjustment
Regulagem Vertical
Ajuste Vertical

At the end of the assembly, insert the screw cover / hole plugs in the apparent holes.
Ao final da montagem, insira a(s) tampa(s) de parafuso / tapa furos nos furos que ficarem aparentes.
Al final del conjunto, coloque la tapa tornillo / tapón plástico en los agujeros que se hagan evidentes.

