

MANUAL DE MONTAGEM

ASSEMBLY INSTRUCTIONS / INSTRUCCIONES DE ARMADO

MESA FÊNIX/BALIZA - 3 GAVETAS
 FÊNIX office table - 3 drawers
 Escritorio FÊNIX - 3 cajones

Código **1184/1238** | Revisão 06

Português
 English
 Español

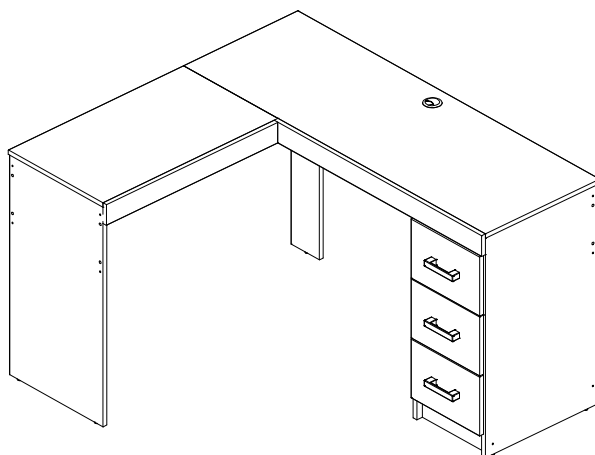
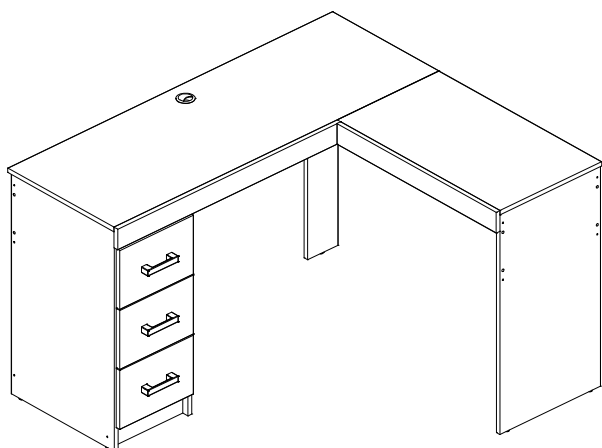

NOTAS: ESSE PRODUTO PODE SER MONTADO COM AS GAVETAS PARA A SUA DIREITA OU ESQUERDA.
NOTES: THIS PRODUCT CAN BE ASSEMBLED WITH DRAWERS TO RIGHT OR LEFT.
NOTAS: ESTE PRODUCTO SE PUEDE ARMAR CON LOS CAJONES A LA DERECHA O IZQUIERDA.

VOCÊ VAI PRECISAR DE / YOU WILL NEED / USTED NECESITARÁ

Ferramentas não fornecidas / Tools not supplied / Herramientas no incluidas

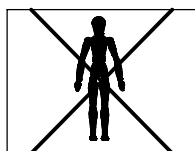

1 Pessoa
 1 Person
 1 Persona

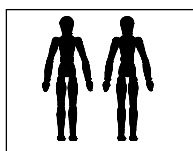

2 Pessoas
 2 People
 2 Personas

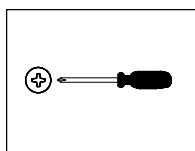

Chave Phillips
 Screwdriver Phillips
 Destornillador cruz

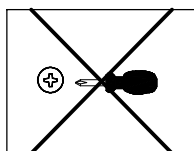

Chave Phillips Menor
 Small screwdriver Phillips
 Destornillador cruz menor

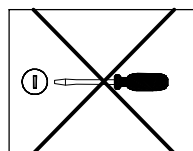

Chave fenda
 Screwdriver slotted
 Destornillador plano

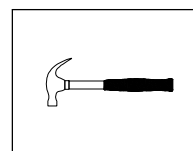

Martelo
 Hammer
 Martillo

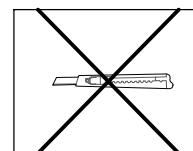

Estilete
 Stylet
 Estilete



Furadeira
 Drill machine
 Taladro

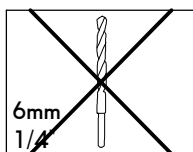

Broca
 Drill bit
 Taladro

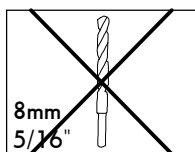

Broca
 Drill bit
 Taladro

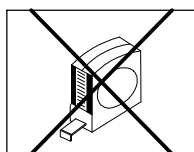



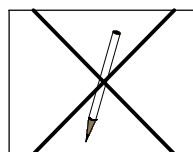











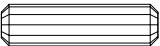

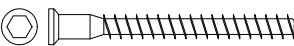

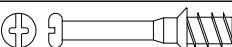

Trena
 Measuring tape
 Cinta de medición

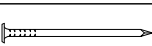
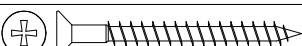
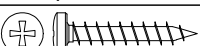
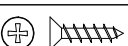

Lápis
 Pencil
 Lápiz

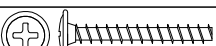
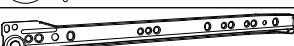
NOTAS: A separação dos acessórios antes de iniciar a montagem facilitará a mesma. Em caso de dúvida no tamanho dos parafusos e cavilhas, utilize a régua ao final da página 2.
NOTES: The separation of the accessories before you start the assembly will facilitate the same. In case of doubt on the size of the screws and bolts, use the ruler to bottom of page 2.
NOTAS: La separación de los accesorios antes de comenzar el armado facilitará el mismo. En caso de duda sobre el tamaño de los tornillos y taquetes, utilice la regla al pie de página 2.

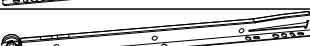
IDENTIFICAÇÃO DOS ACESSÓRIOS/ IDENTIFICATION OF ACCESSORIES/ IDENTIFICACIÓN DE ACCESORIOS

A1		Cola / Glue / Pegamento	13 g	1
A2		Sapata redonda / Small plastic foot / Pie plástico	14 mm	7
A4		Cantoneira de metal / Metallic bracket / Suporte de metal	22x22 mm	3
B5		Cantoneira de metal / Metallic angle plates / Suporte de metal	46 mm	3
B6		Junção de tampos / Junction of tops / Unión de tapas	40x40 mm	2
E		Cavilha / Wooden dowel / Taquete	8x30 mm	38
F		Cavilha / Wooden dowel / Taquete	8x50 mm	1
G		Parafuso estrutural / Structural screw / Tornillo estructural	5,0x50 mm	10
H		Chave allen / Allen key / Liave allen	3 mm	1
H9		Tapa furo plástico / Plastic hole plugs / Tapones plásticos	5 mm	5
I		Tampa parafuso estrutural / Structural screw cover / Tapa tornillo estructural	-	8
J		Haste minifix simples / Simple minifix screw / Tornillo minifix simple	-	15
K3		Puxador Lusa / Handle / Tirador	96 mm	3
K4		Suporte fixação vistas / Fixing bracket of frames / Soporte de fijación molduras	-	3
L		Tambor minifix / Drum lock / Tambor minifix	12 mm	15
M		Tapa furo adesivo / Bore patch adhesive / Tapones adhesivo	-	7
N		Prego / Nail / Clavo	10 x10	7
O		Parafuso chato / Flat head screw / Tornillo de cabeza plana	4,5x45 mm	6
P		Parafuso panela / Pan head screw / Tornillo de pan	4,5x25 mm	2
P5		Parafuso chato especial / Flat head screw / Tornillo de cabeza plana	3,5x14 mm	24
P6		Passa fios / Pass wires / Pasar cables	46 mm	1
S		Parafuso panela / Pan head screw / Tornillo de pan	3,5x14 mm	32
T		Parafuso flangeado / Flanged head screw / Tornillo de cabeza flangeada	3,5x25 mm	6
VA		Corrediça lateral esquerda / Metallic slide the left field / Corredera lateral izquierda	350 mm	3
VB		Corrediça lateral direita / Metallic slide the right field / Corredera lateral derecha	350 mm	3
VC		Corrediça gaveta esquerda / Drawer slide left / Corredera izquierda cajón	350 mm	3
VD		Corrediça gaveta direita / Drawer slide right / Corredera derecha cajón	350 mm	3
Z		Tapa furo plástico / Plastic hole plugs / Tapones plásticos	8 mm	8



IDENTIFICAÇÃO DAS PEÇAS / PARTS IDENTIFICATION/ IDENTIFICACIÓN DE LAS PIEZAS

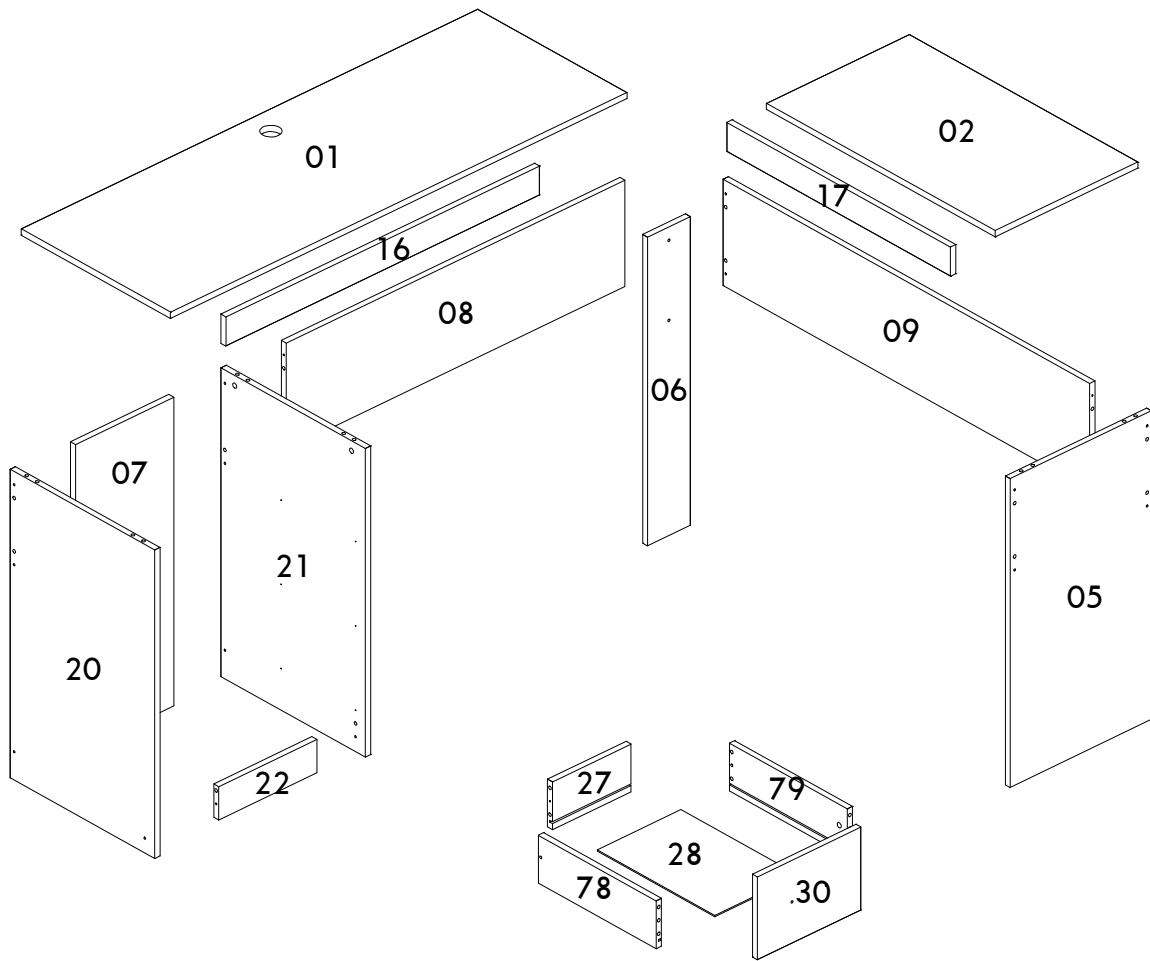

Número / Number / Número	Medidas / Measures / Medidas		Qtd. / Qty. / Qtd.
	cm	inches	
01	127,8 x 45 x 1,5	50" 3/8 x 17" 3/4 x 5/8	1
02	68,9 x 40 x 1,5	27" 1/8 x 15" 3/4 x 5/8	1
05	74 x 39,6 x 1,5	29" 1/8 x 15" 5/8 x 5/8	1
06	74 x 12 x 1,5	29" 1/8 x 4" 3/4 x 5/8	1
07	74 x 27,5 x 1,5	29" 1/8 x 10" 7/8 x 5/8	1
08	94,8 x 25,5 x 1,5	37" 3/8 x 10" x 5/8	1
09	110,5 x 25,5 x 1,5	43" 1/2 x 10" x 5/8	1
16	87,8 x 7 x 1,5	34" 5/8 x 2" 3/4 x 5/8	1
17	67,4 x 7 x 1,5	26" 1/2 x 2" 3/4 x 5/8	1
20	74 x 43,6 x 1,5	29" 1/8 x 17" 1/8 x 5/8	1
21	74 x 43,6 x 1,5	29" 1/8 x 17" 1/8 x 5/8	1
22	27,5 x 8 x 1,5	10" 7/8 x 3" 1/8 x 5/8	1
27	22 x 11,5 x 1,5	8" 5/8 x 4" 1/2 x 5/8	3
28	23,4 x 35,4 x 0,3	9" 1/4 x 13" 7/8 x 1/8	3
30	29 x 19,9 x 1,5	11" 3/8 x 7" 3/4 x 5/8	3
78	35,5 x 11,5 x 1,5	14" x 4" 1/2 x 5/8	3
79	35,5 x 11,5 x 1,5	14" x 4" 1/2 x 5/8	3

01

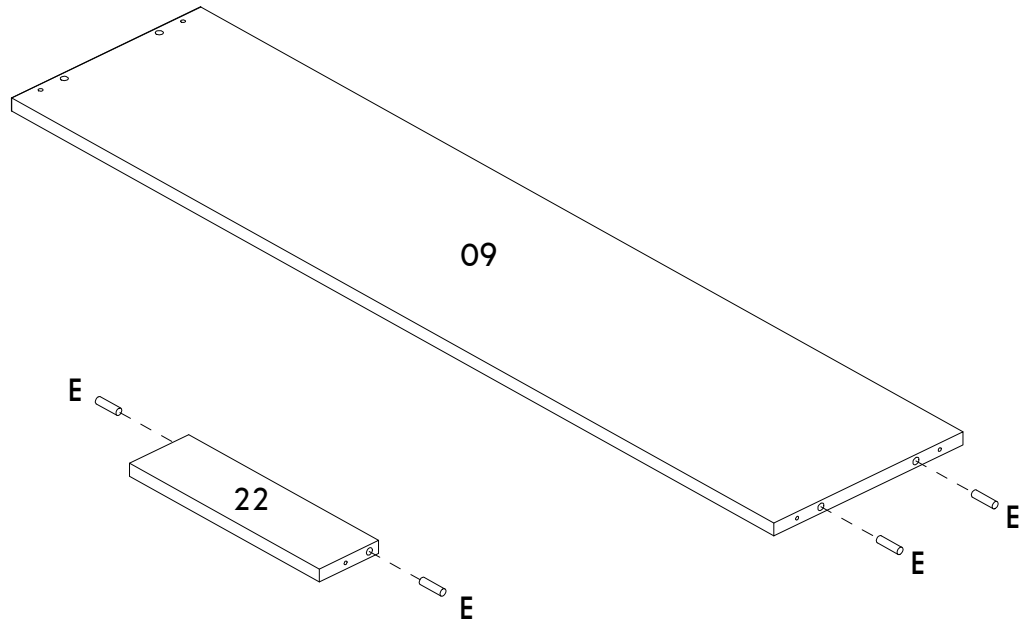
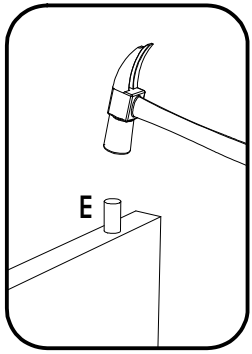

02

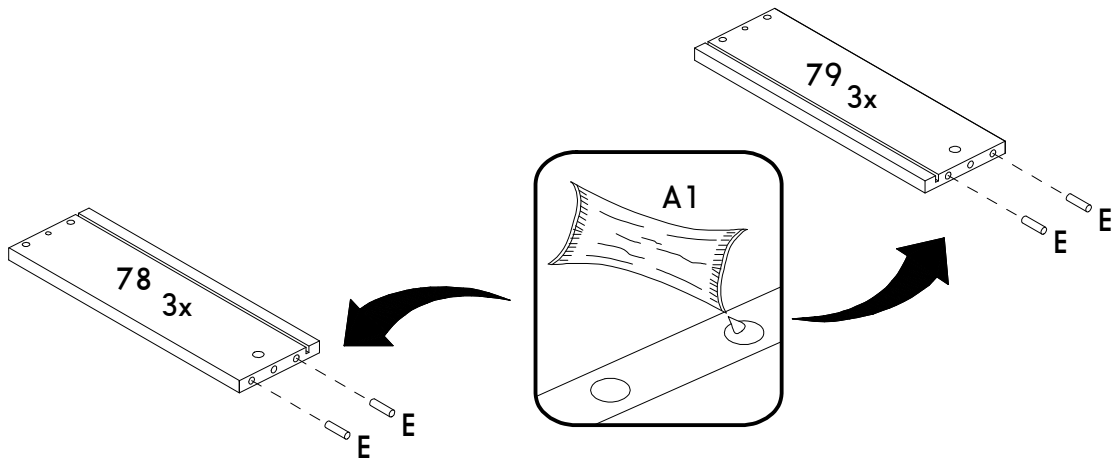

03

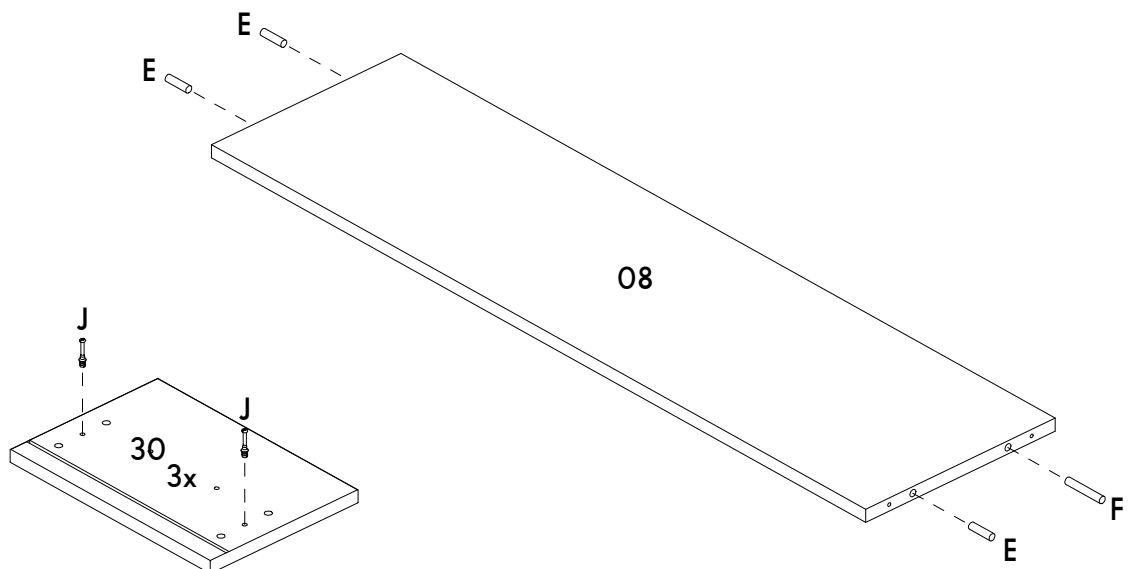
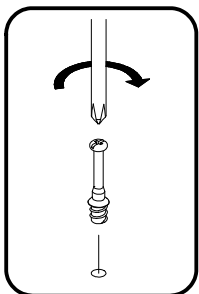

04

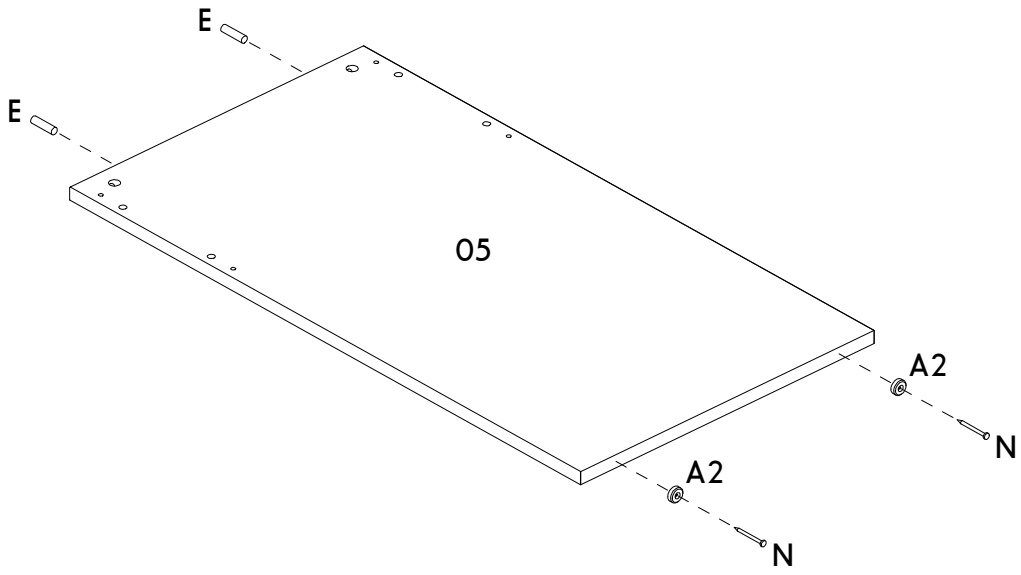

05

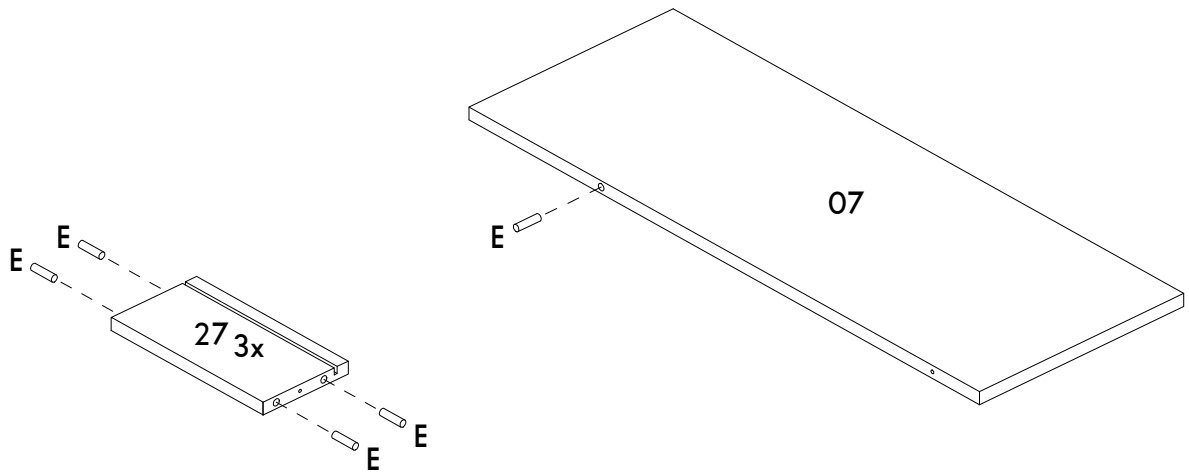

06

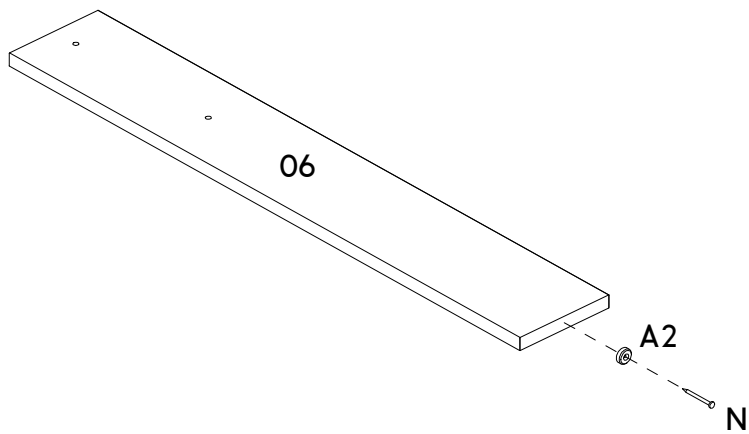

07

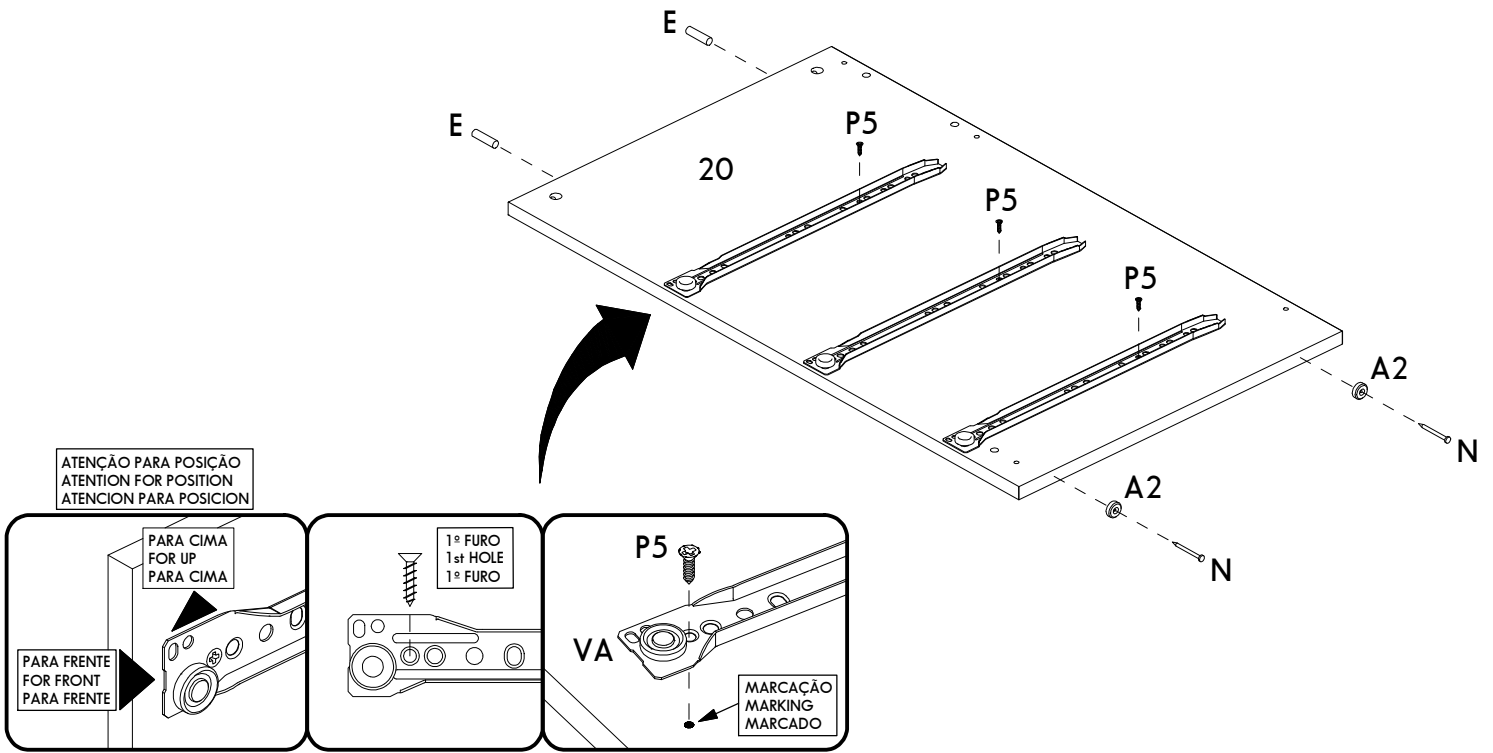

08

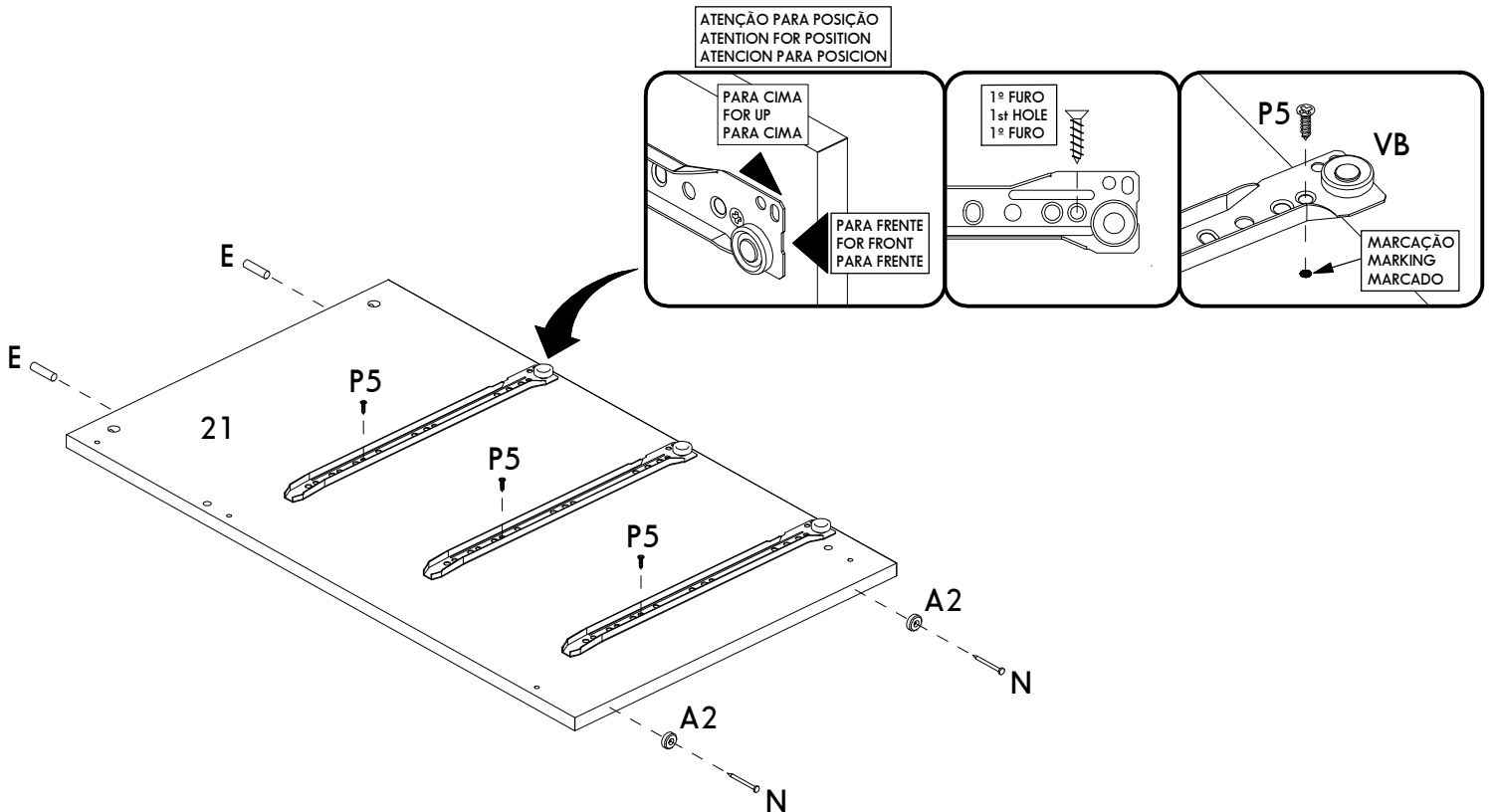

09

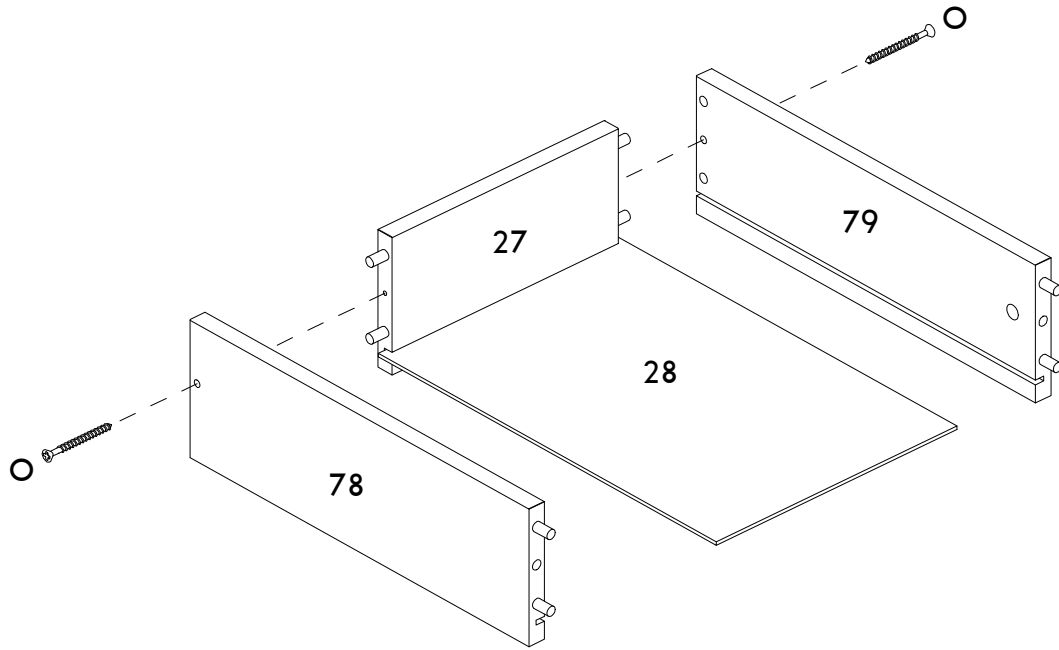

10

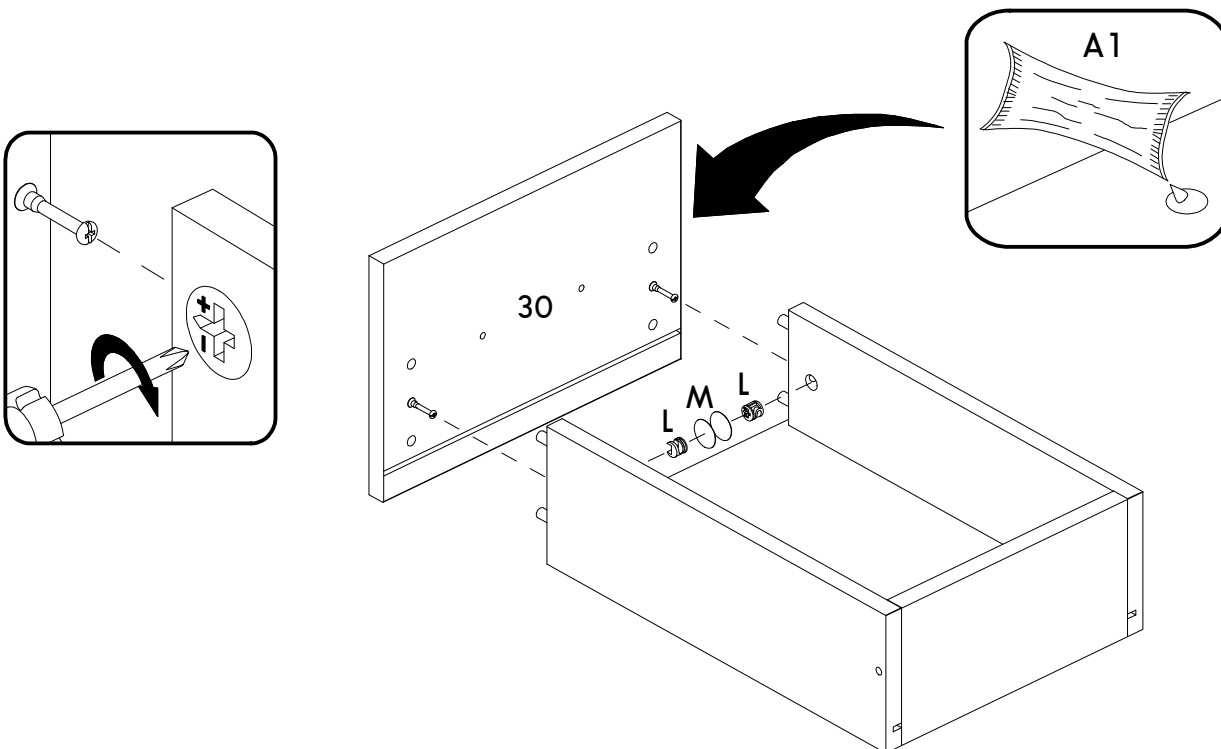

11

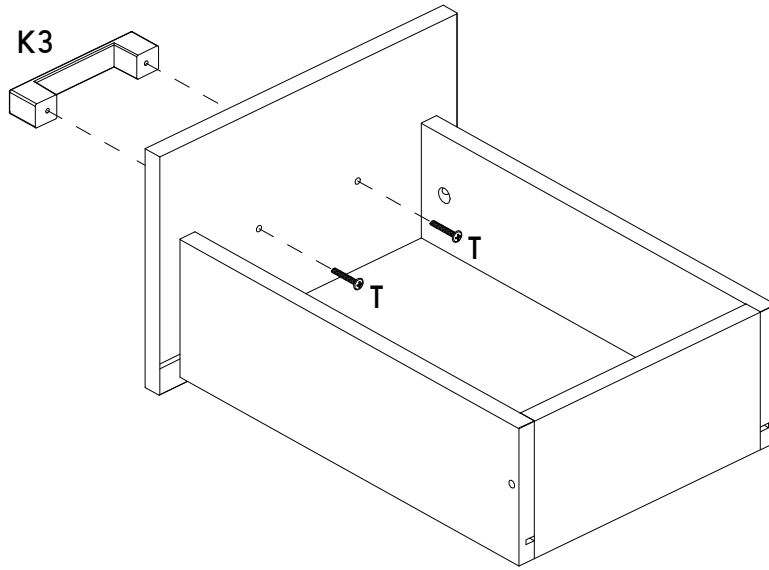

12

LADO INFERIOR DA GAVETA
THE UNDERSIDE OF THE DRAWER
PARTE INFERIOR DEL CAJÓN

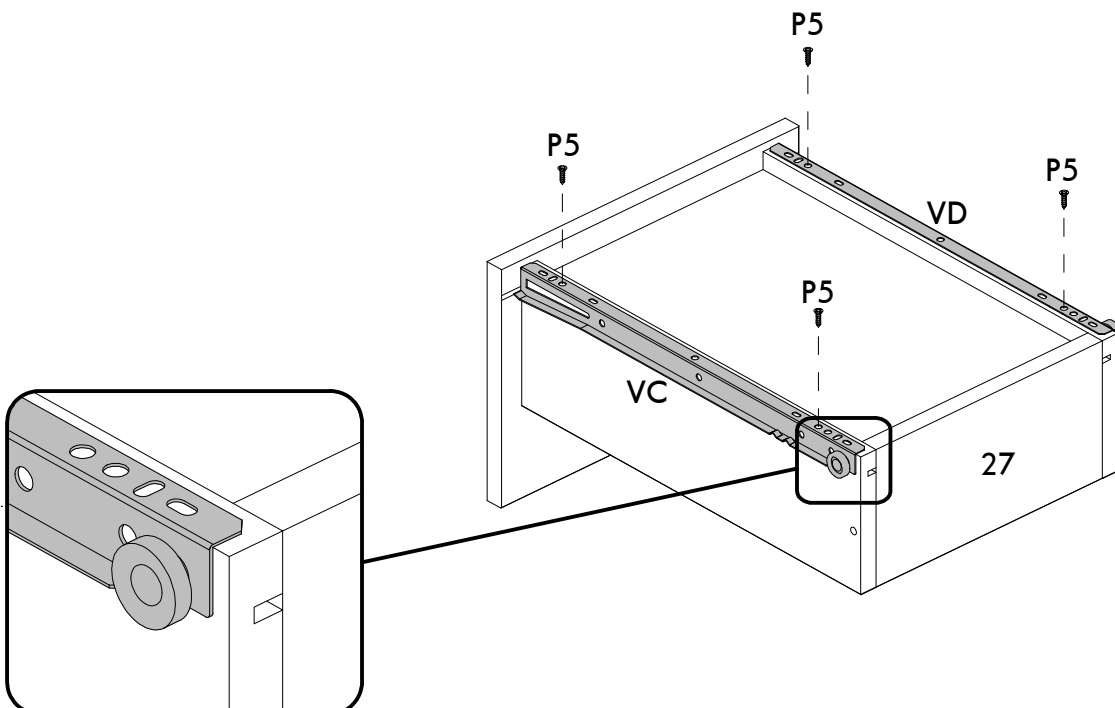

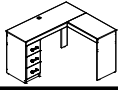

13

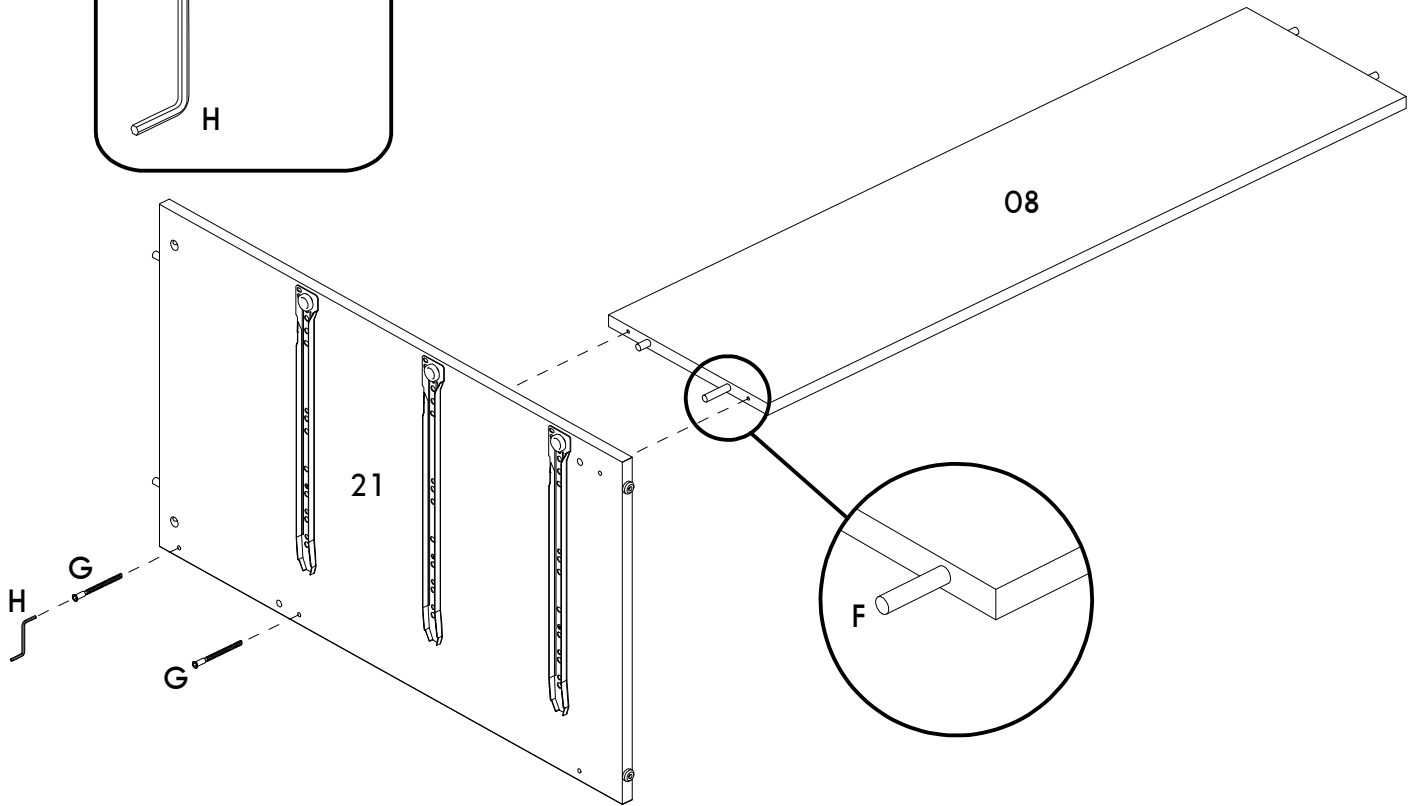
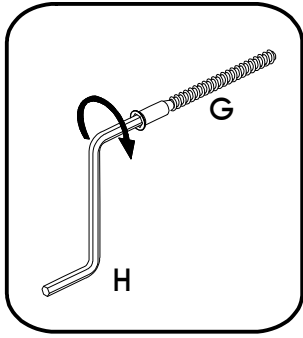

14

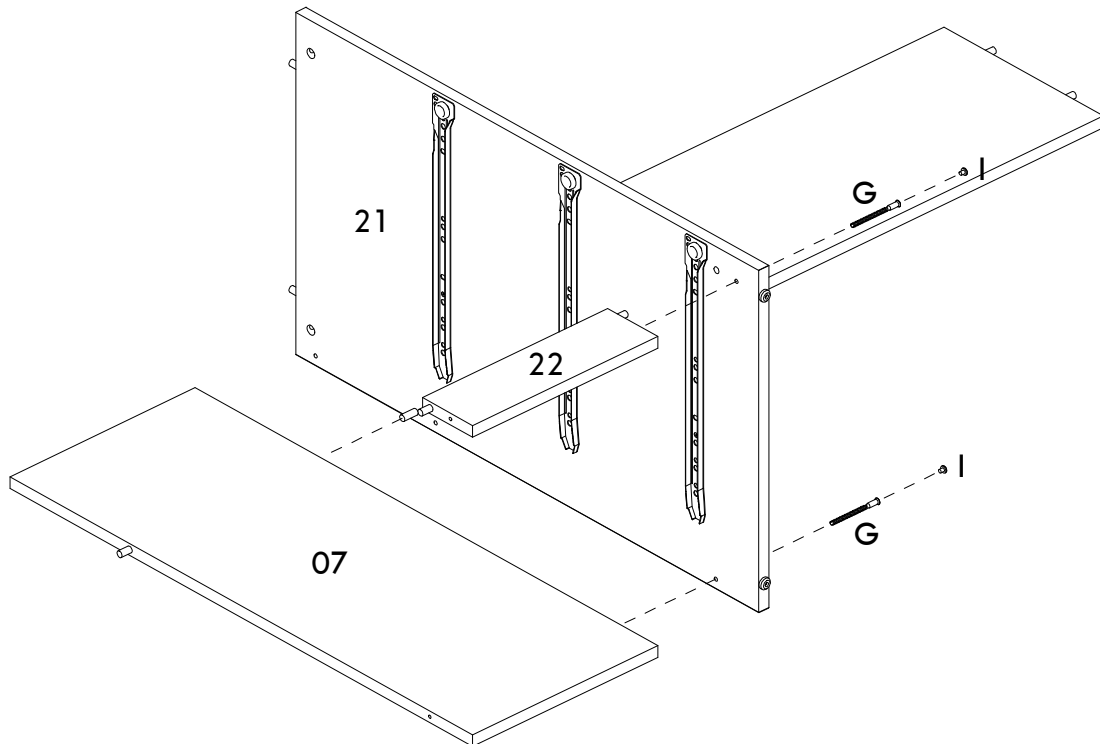

15

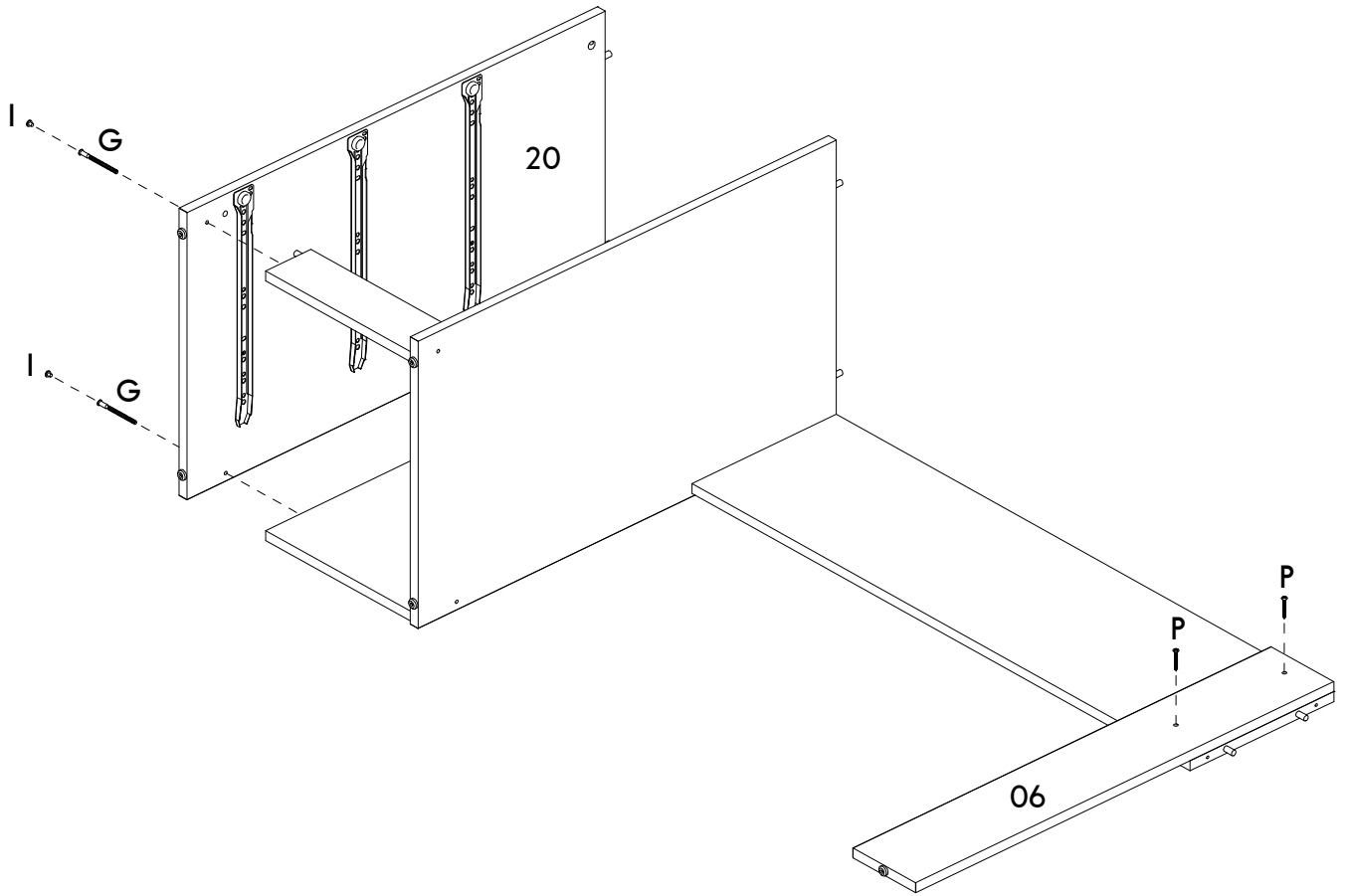

16

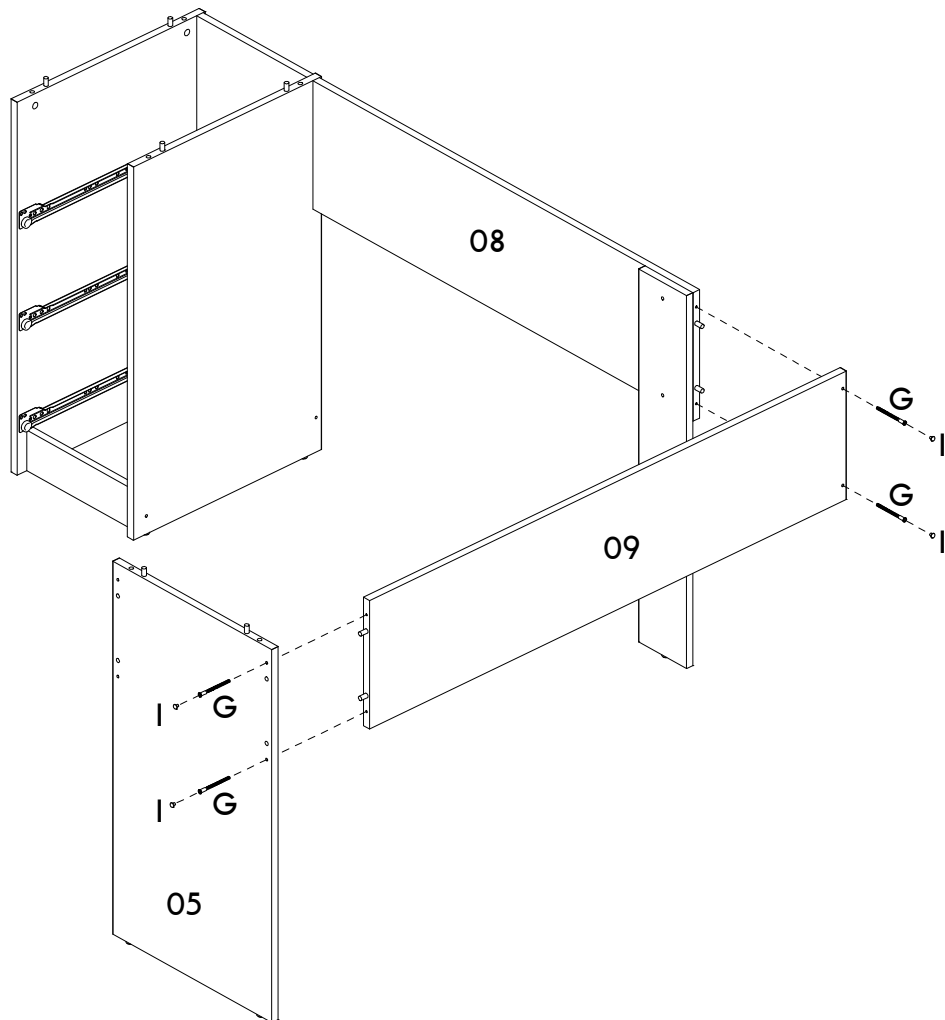

17

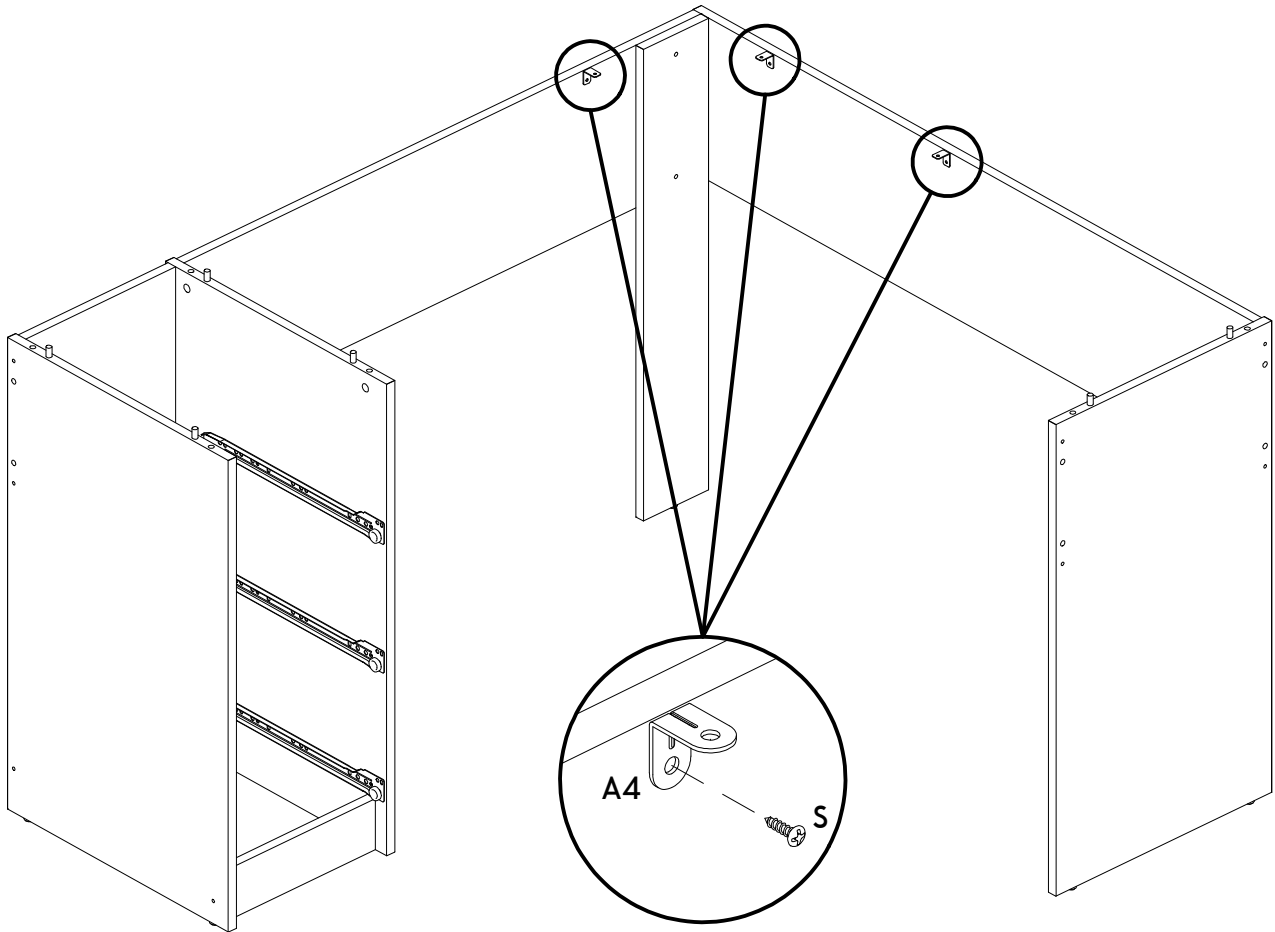

18

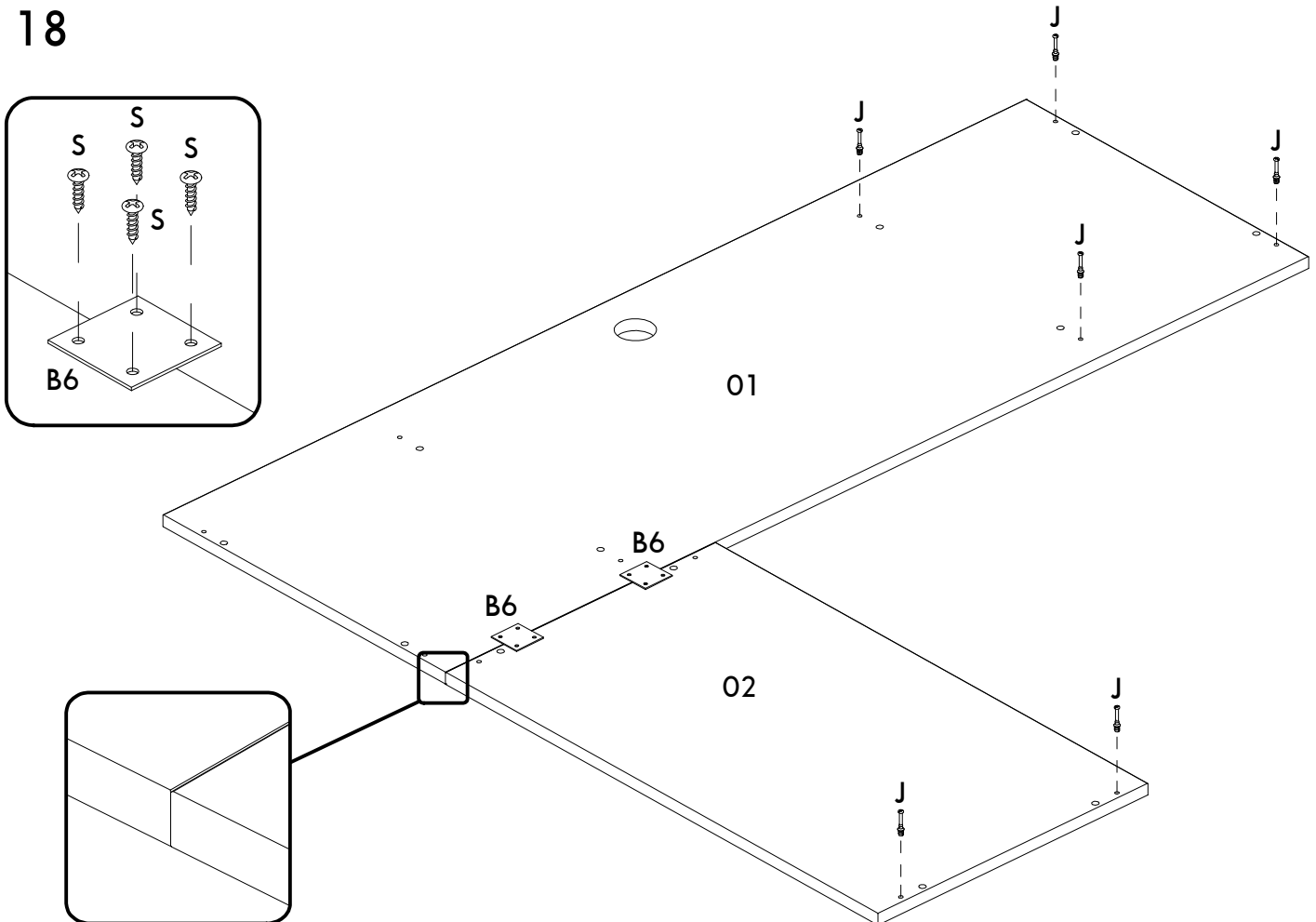

19

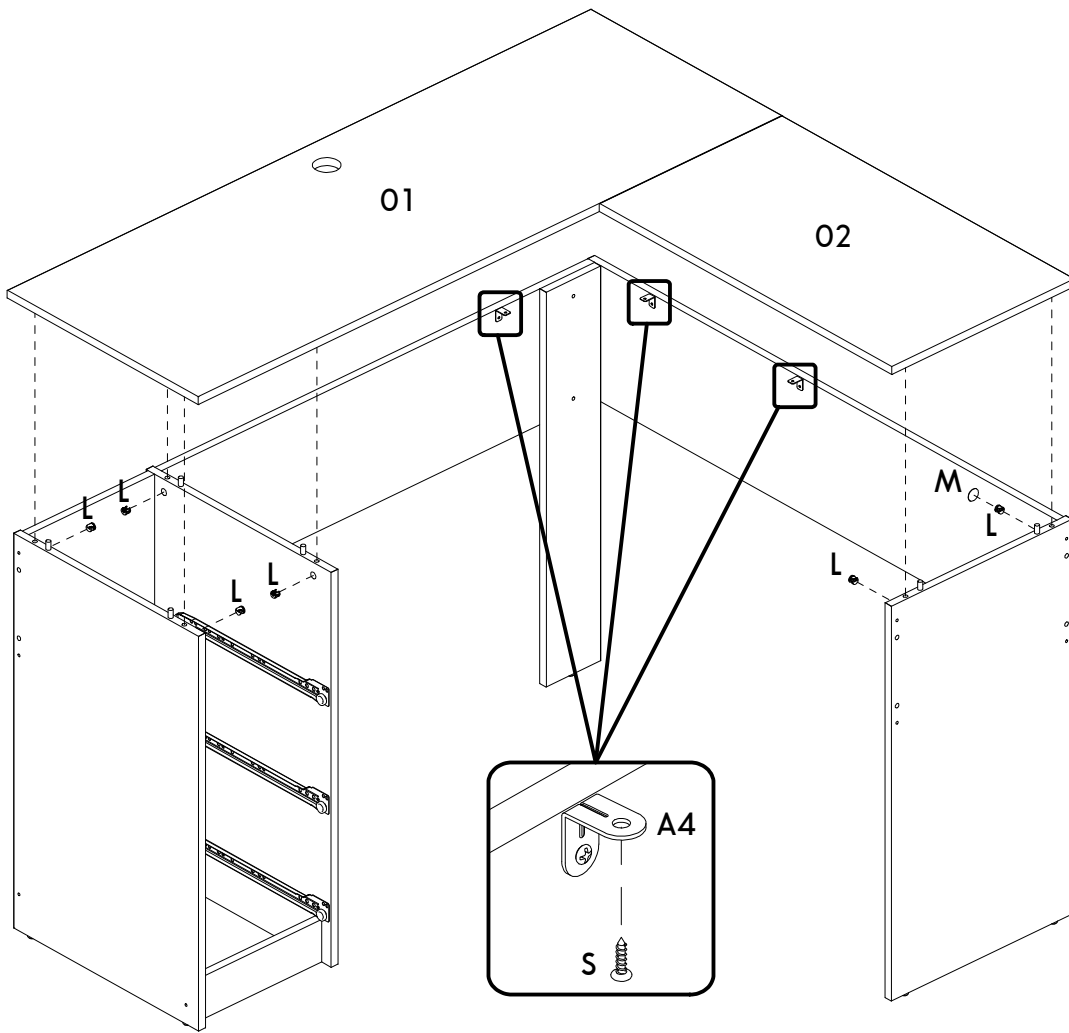

20

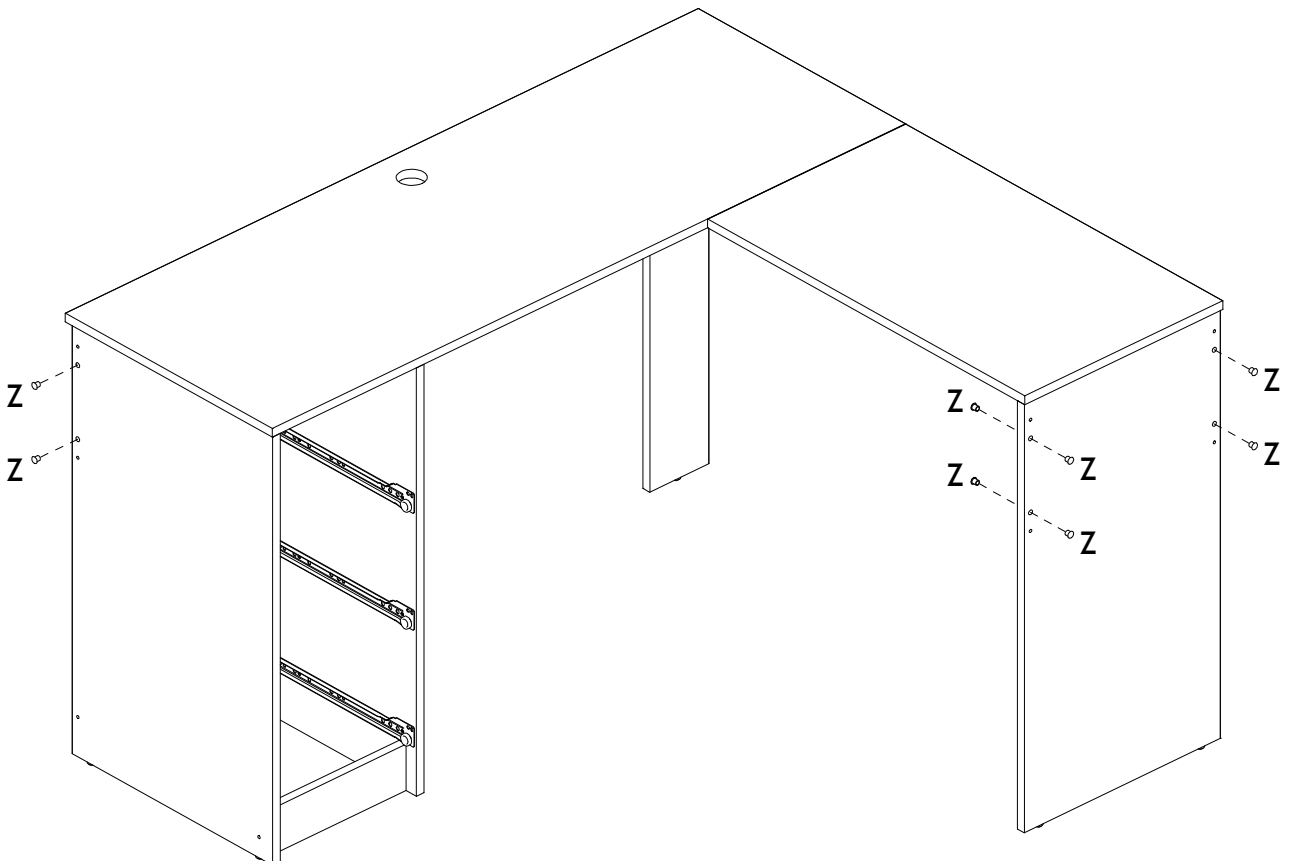

21

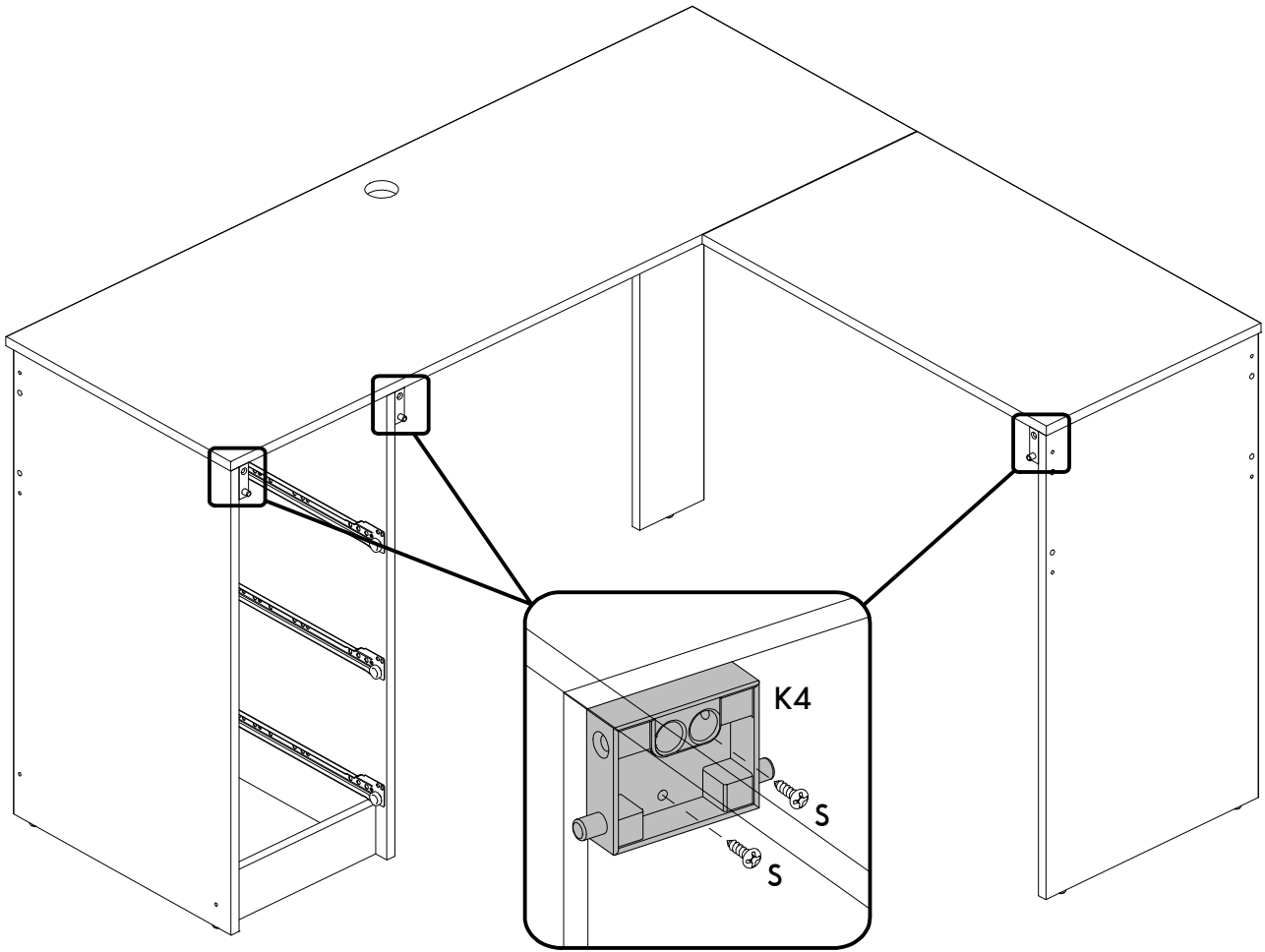

22

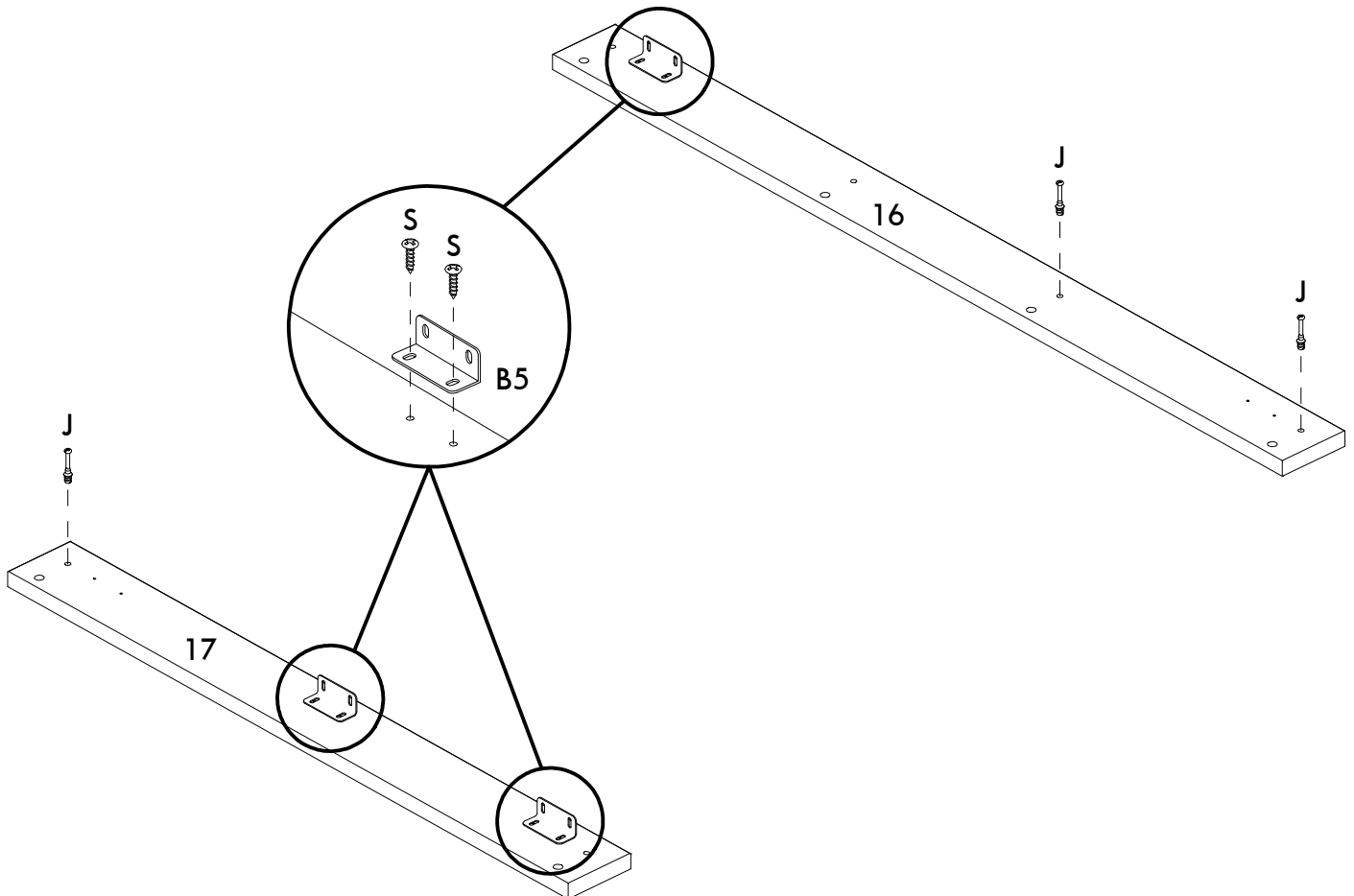

23

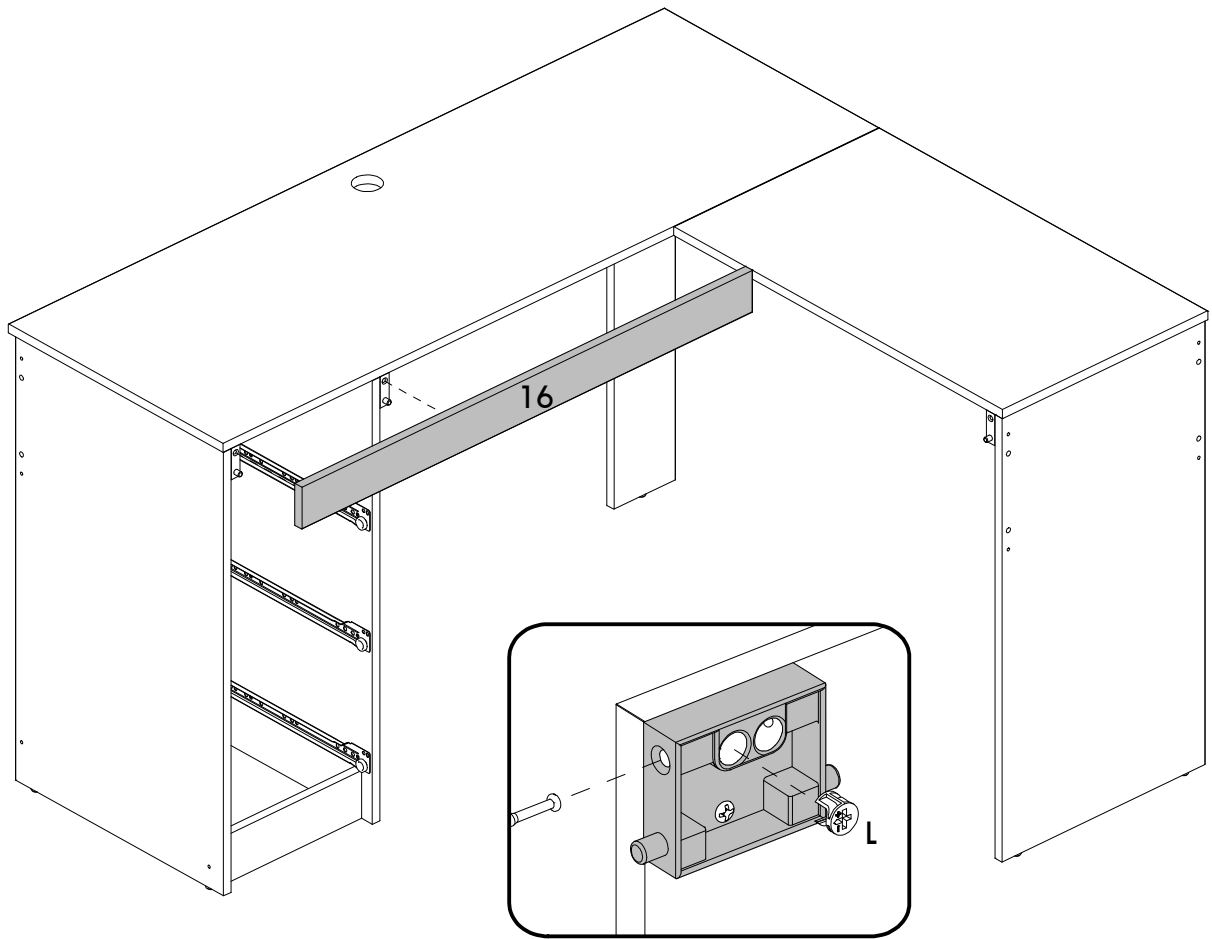

24

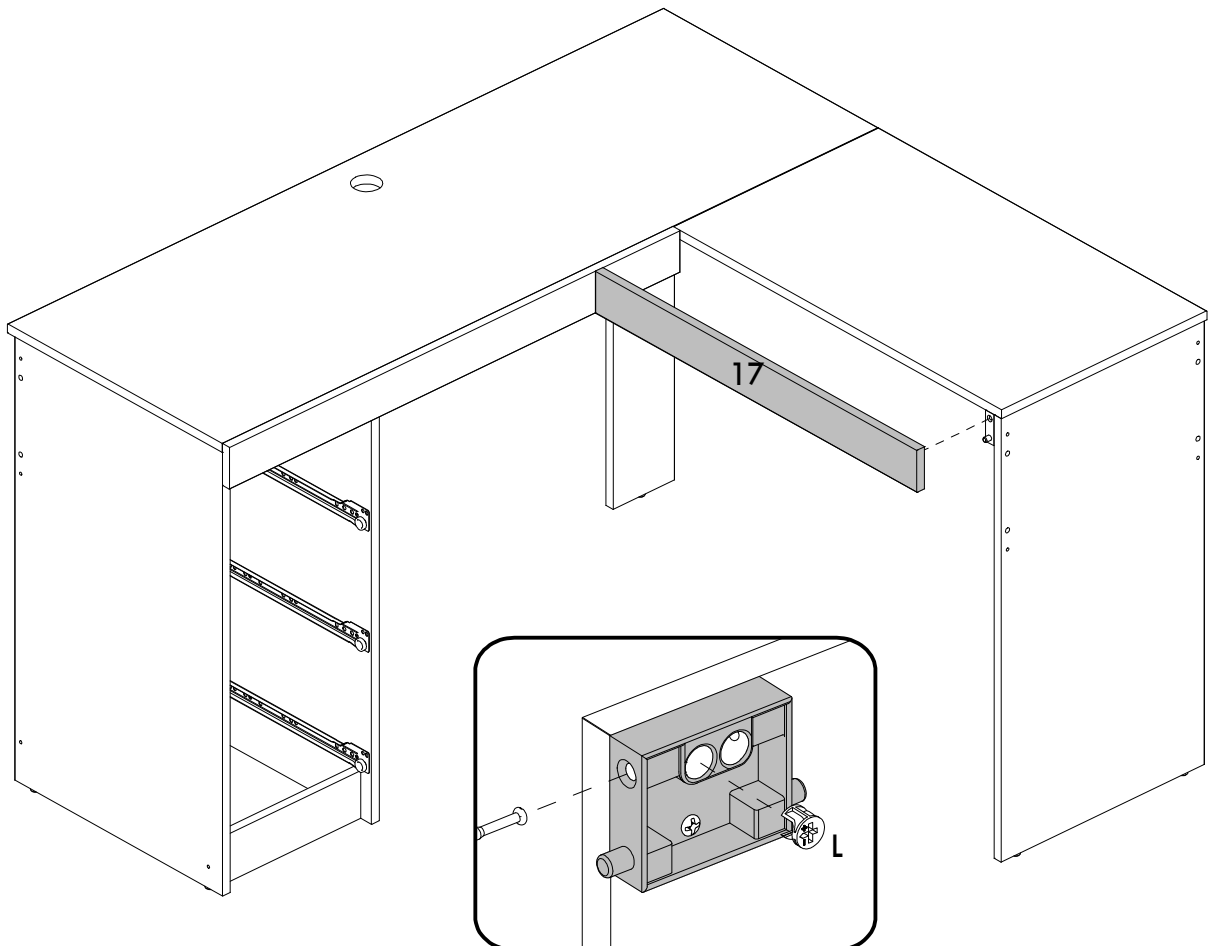

25

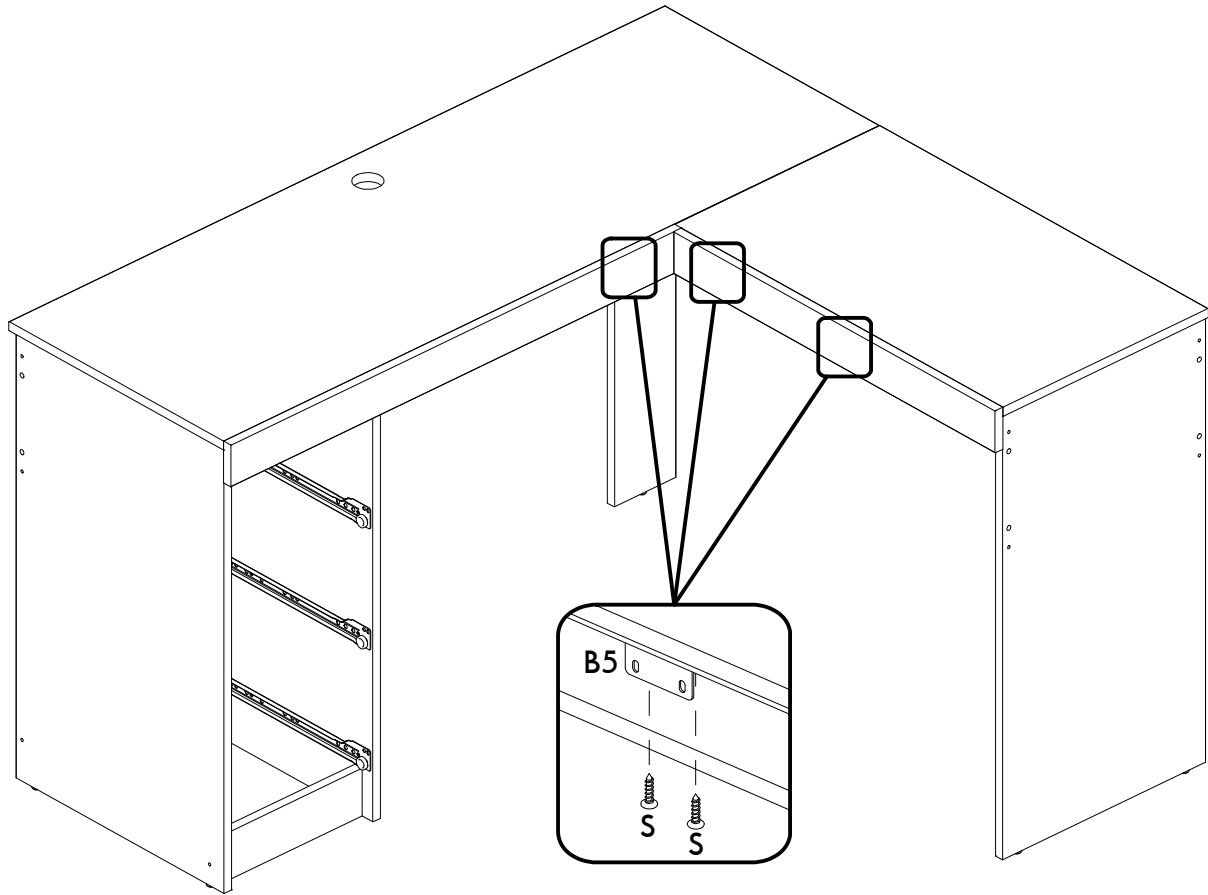

26

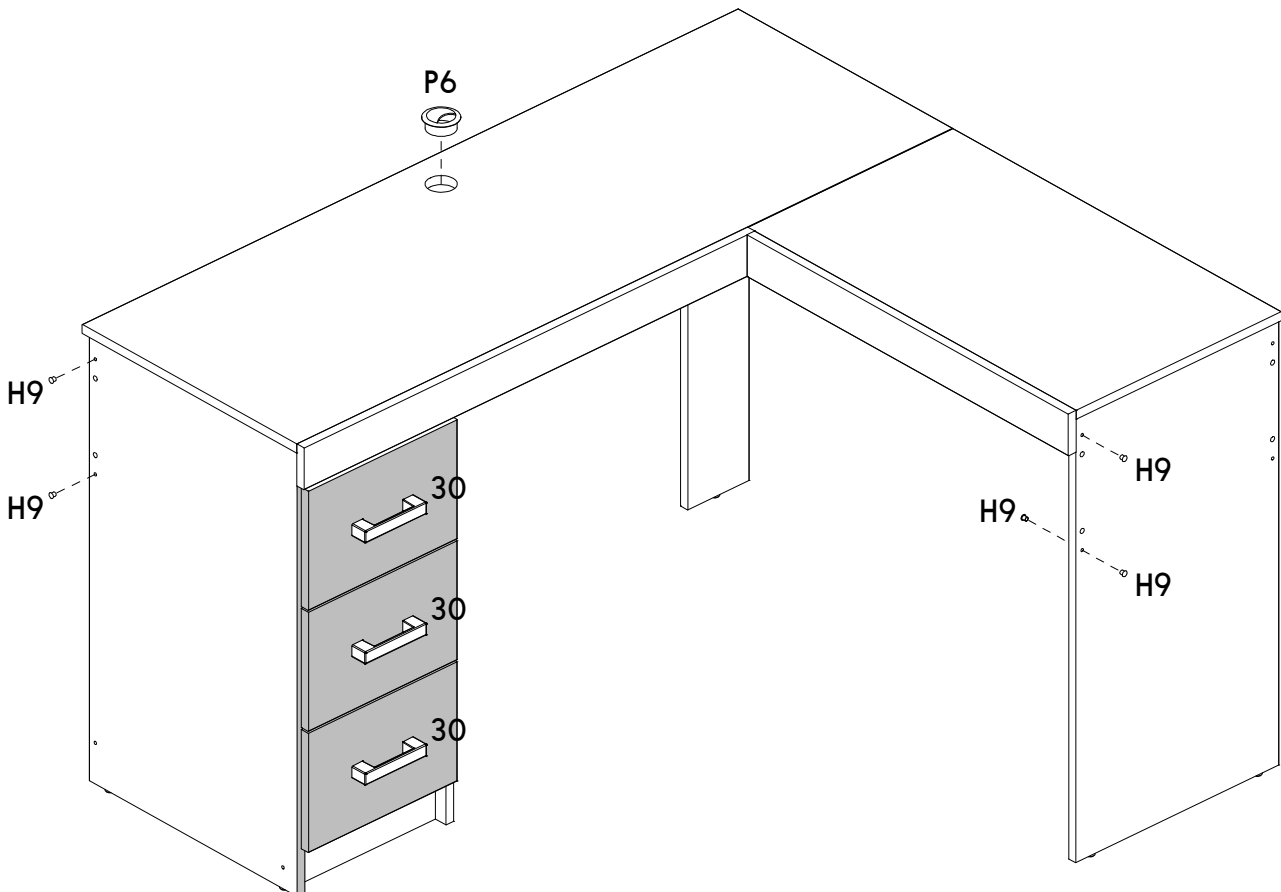

13

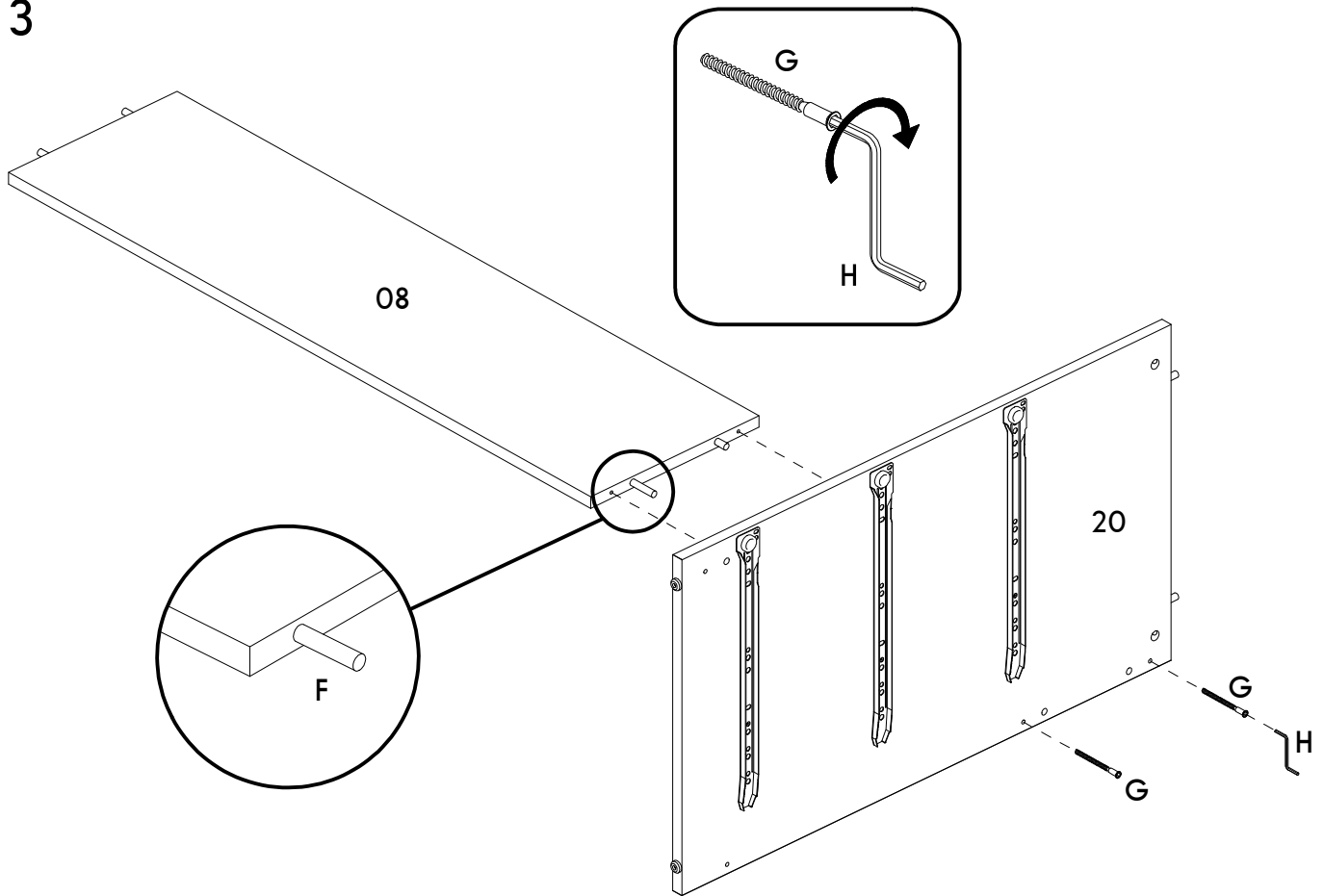

14

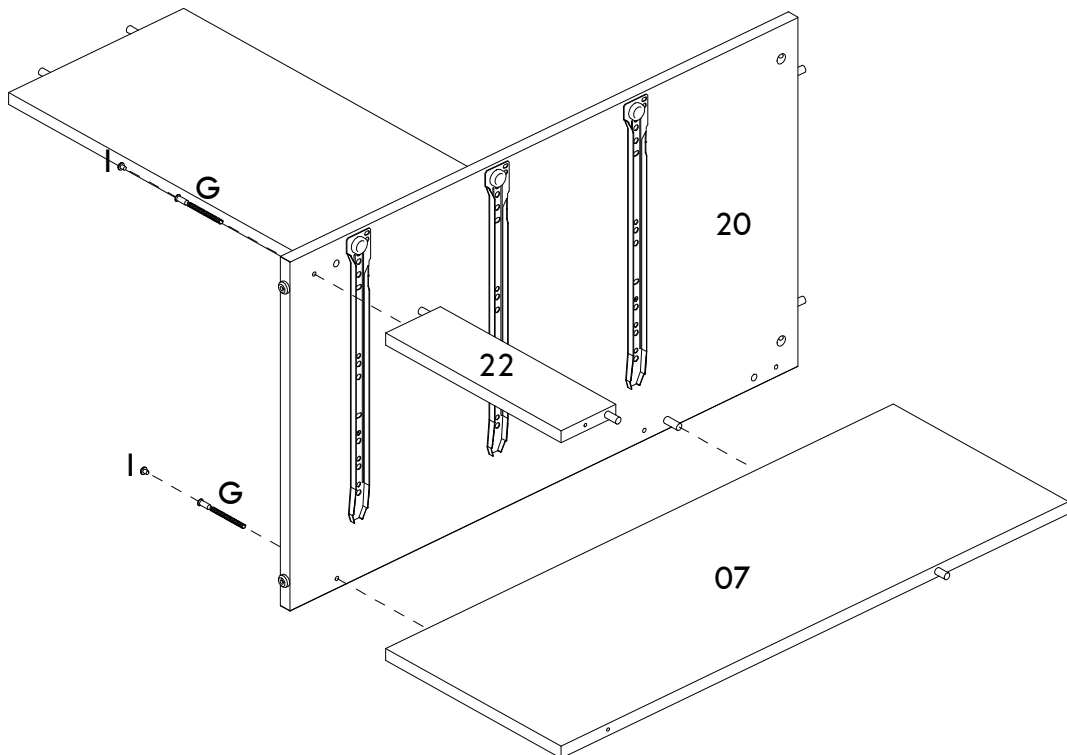

15

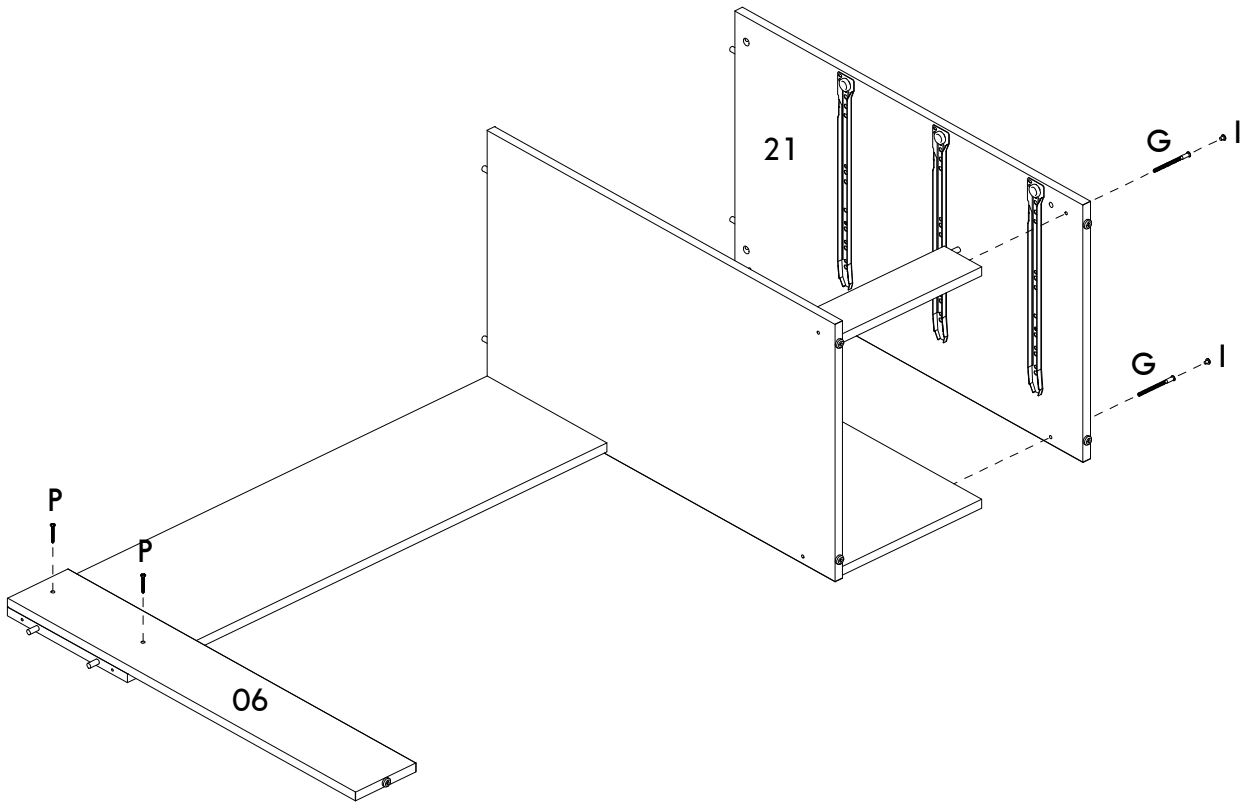

16

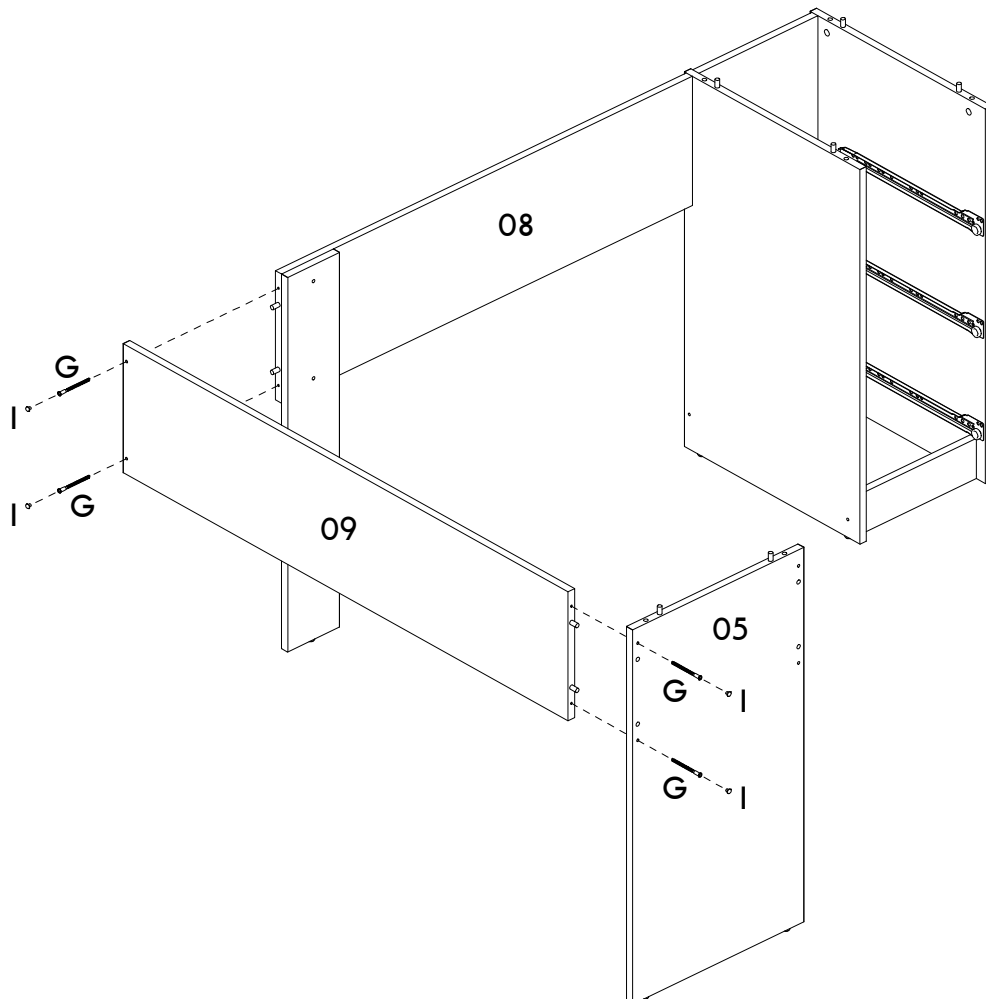

17

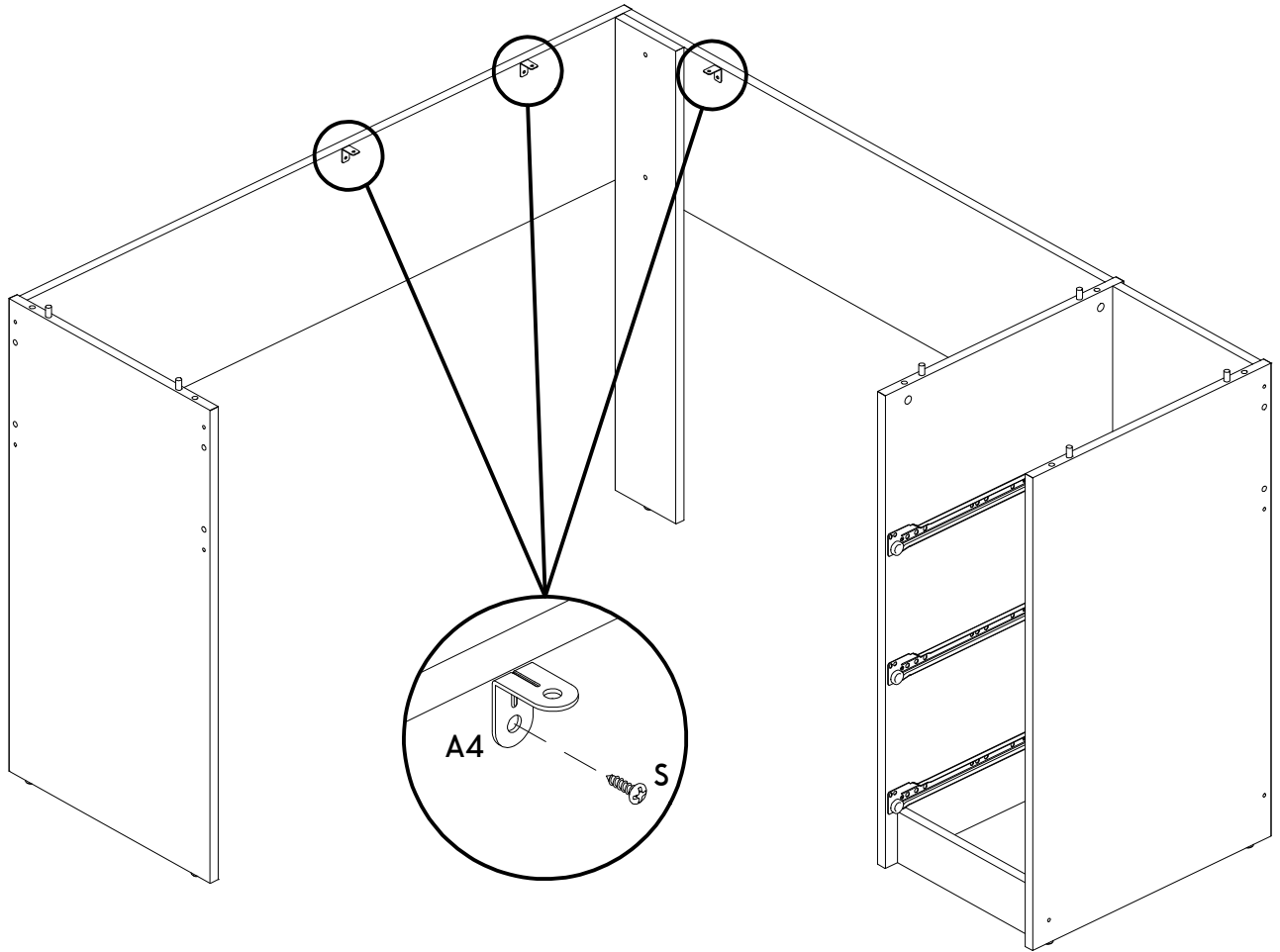

18

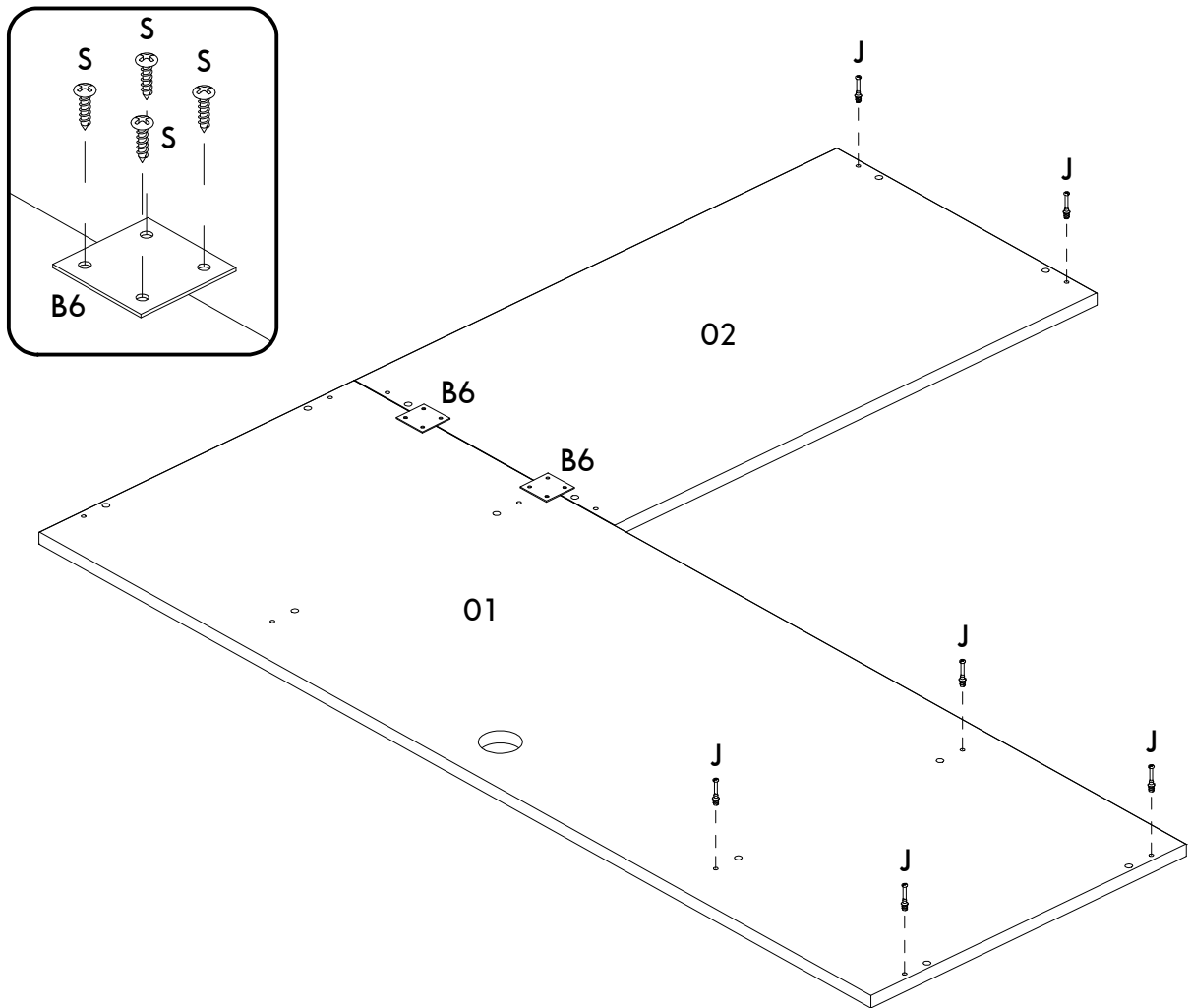

19

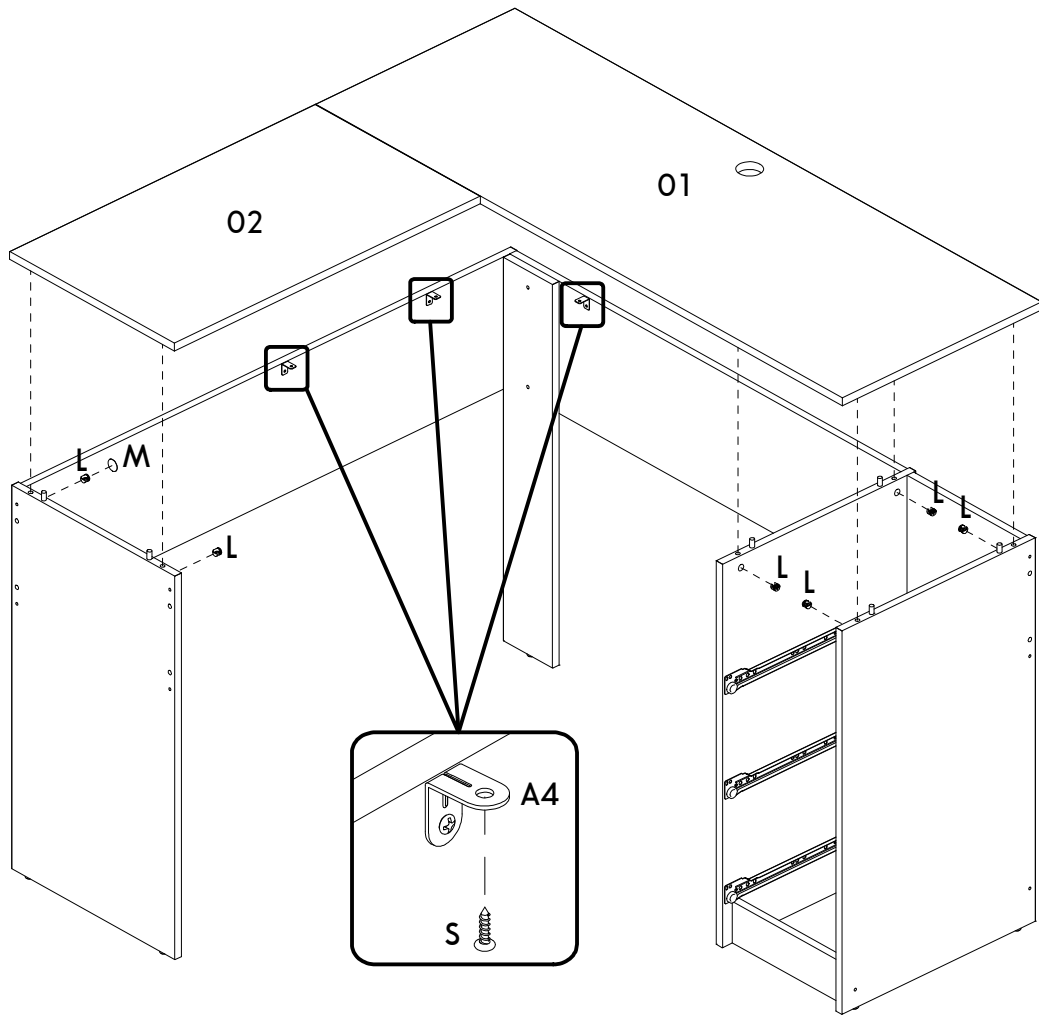

20

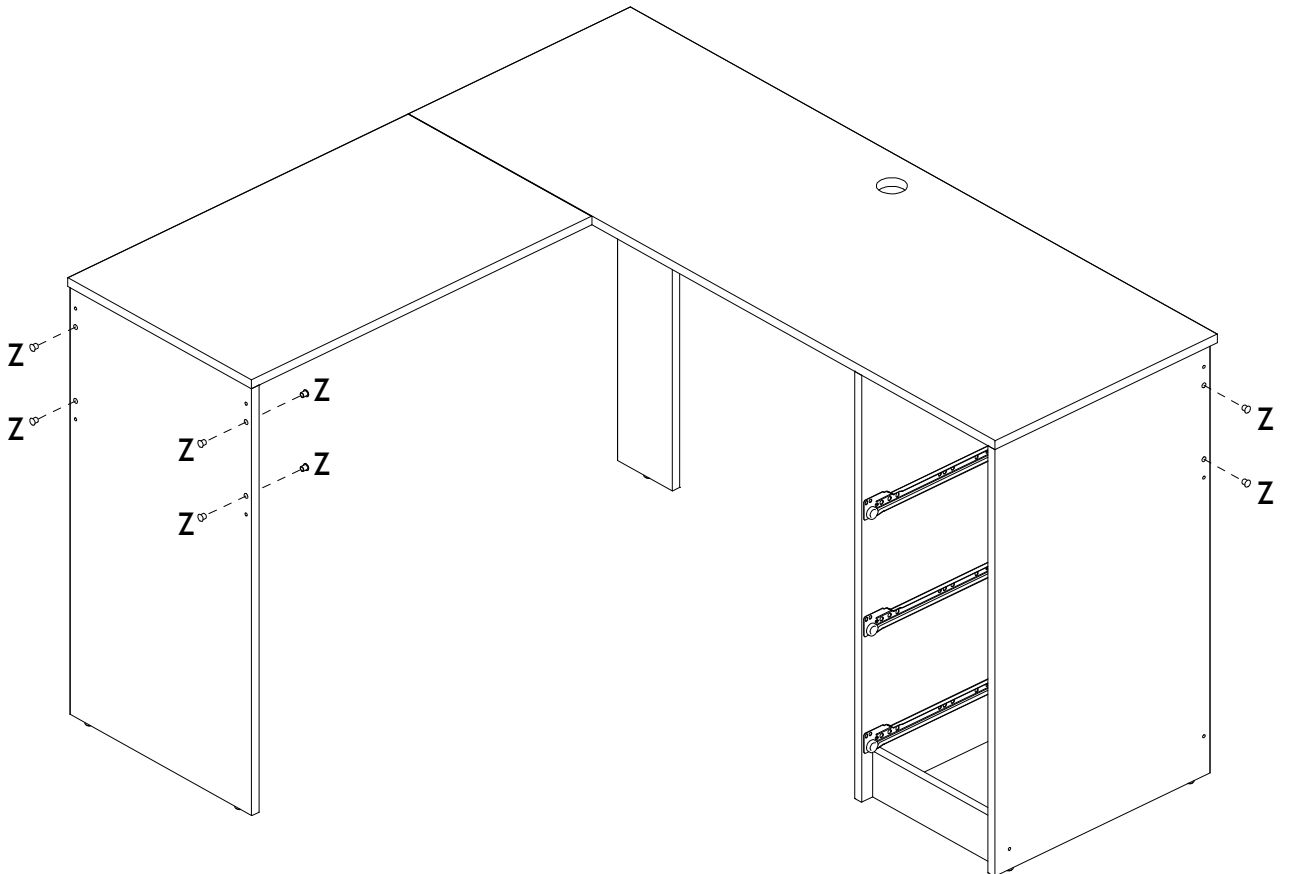

21

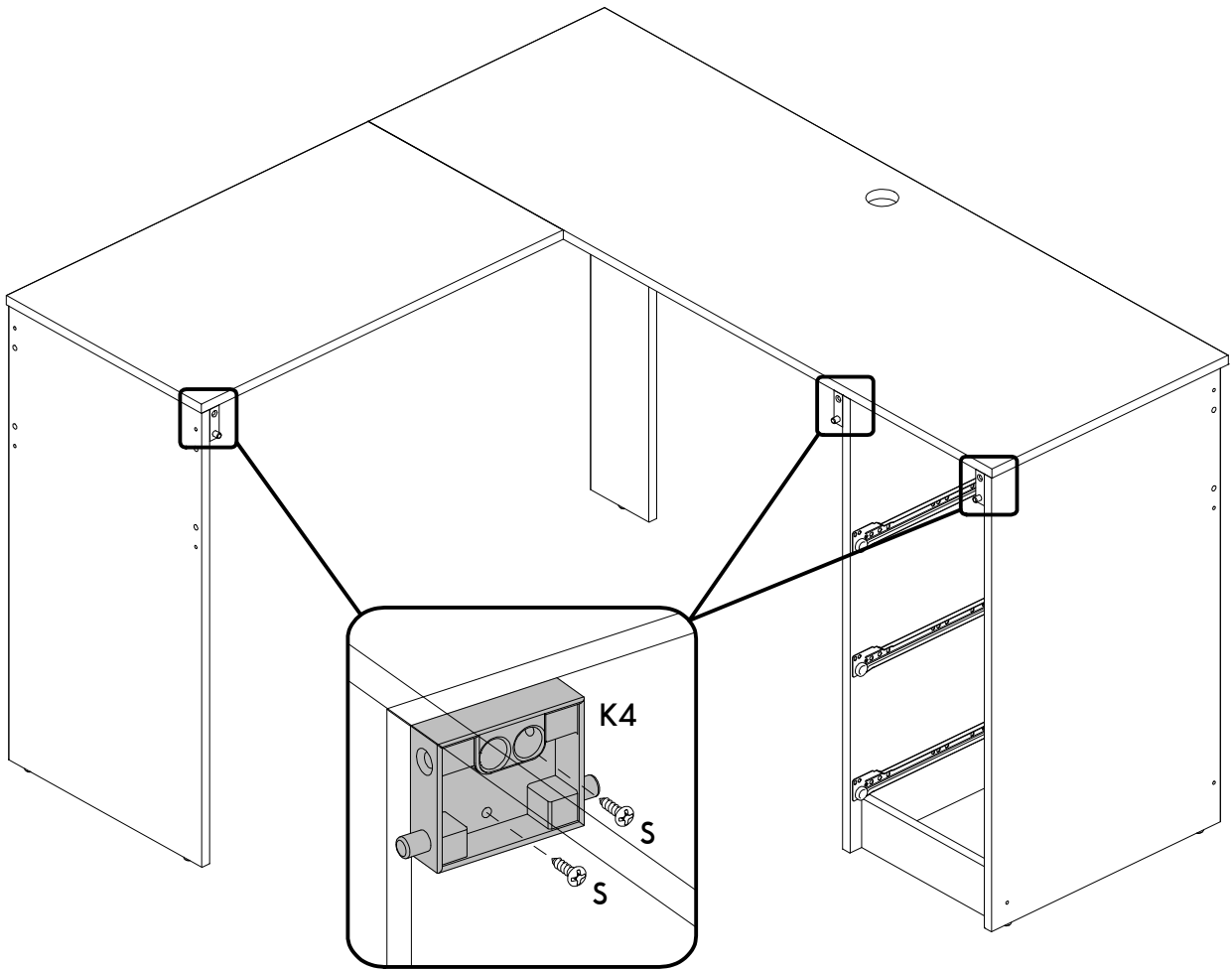

22

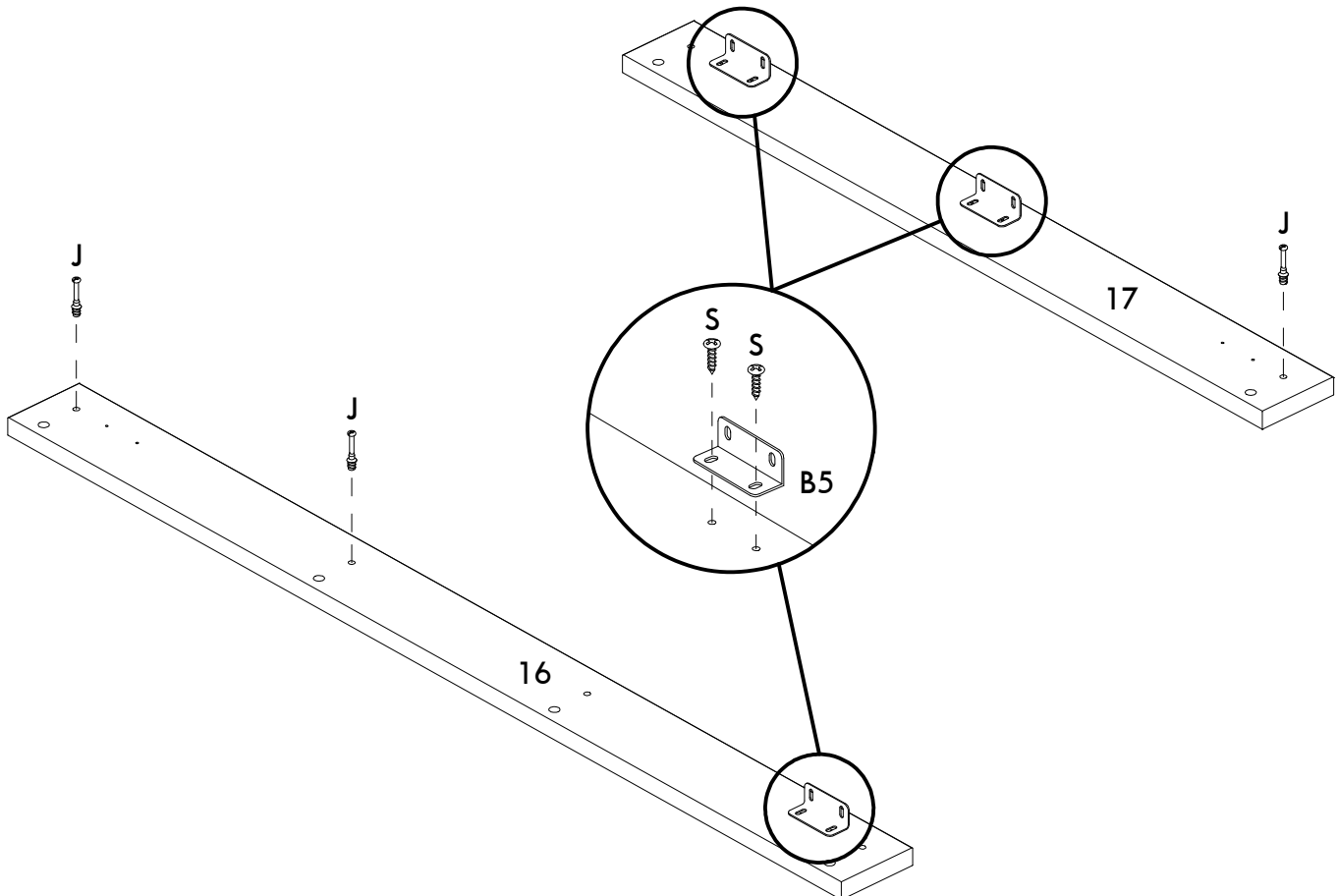

23

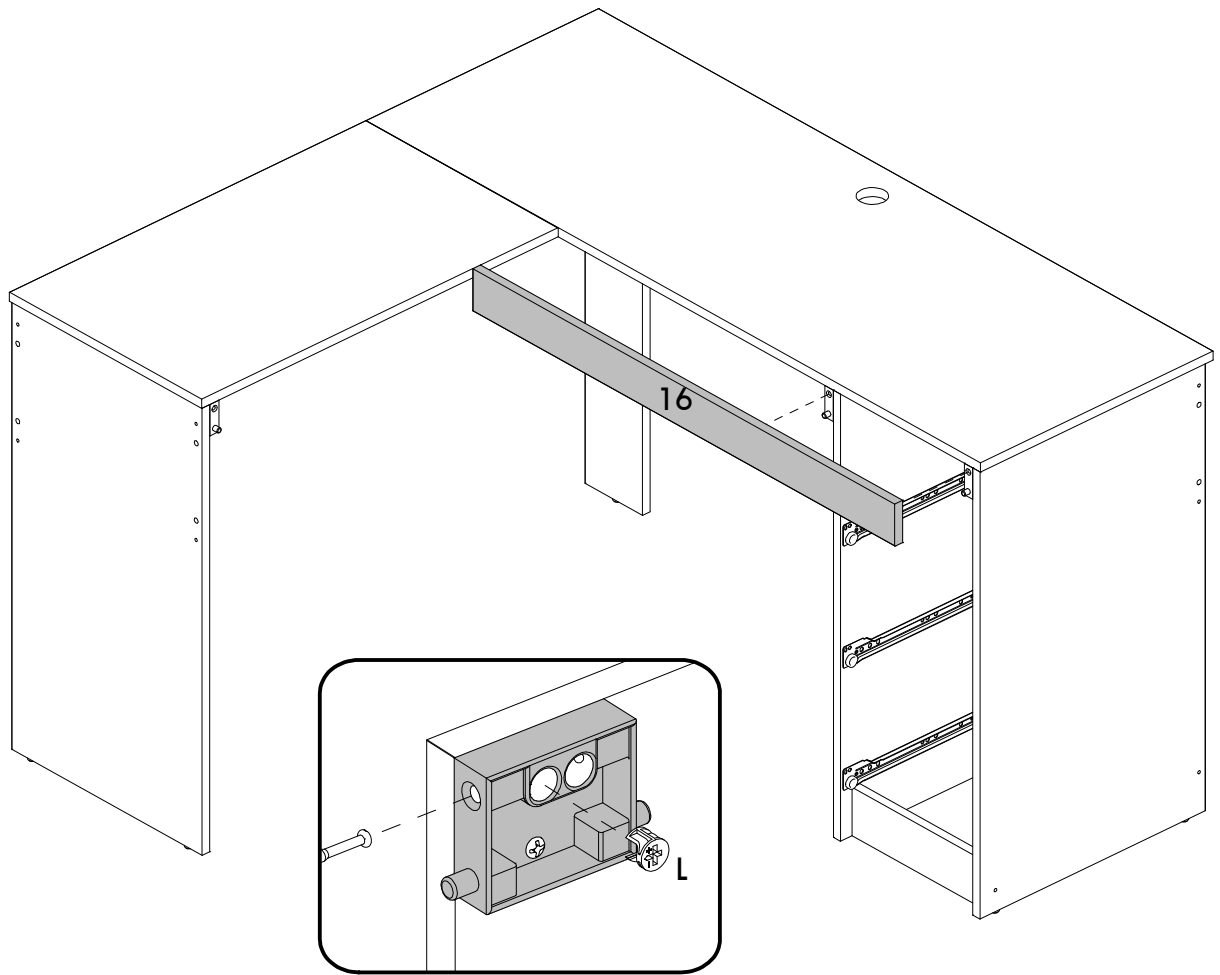

24

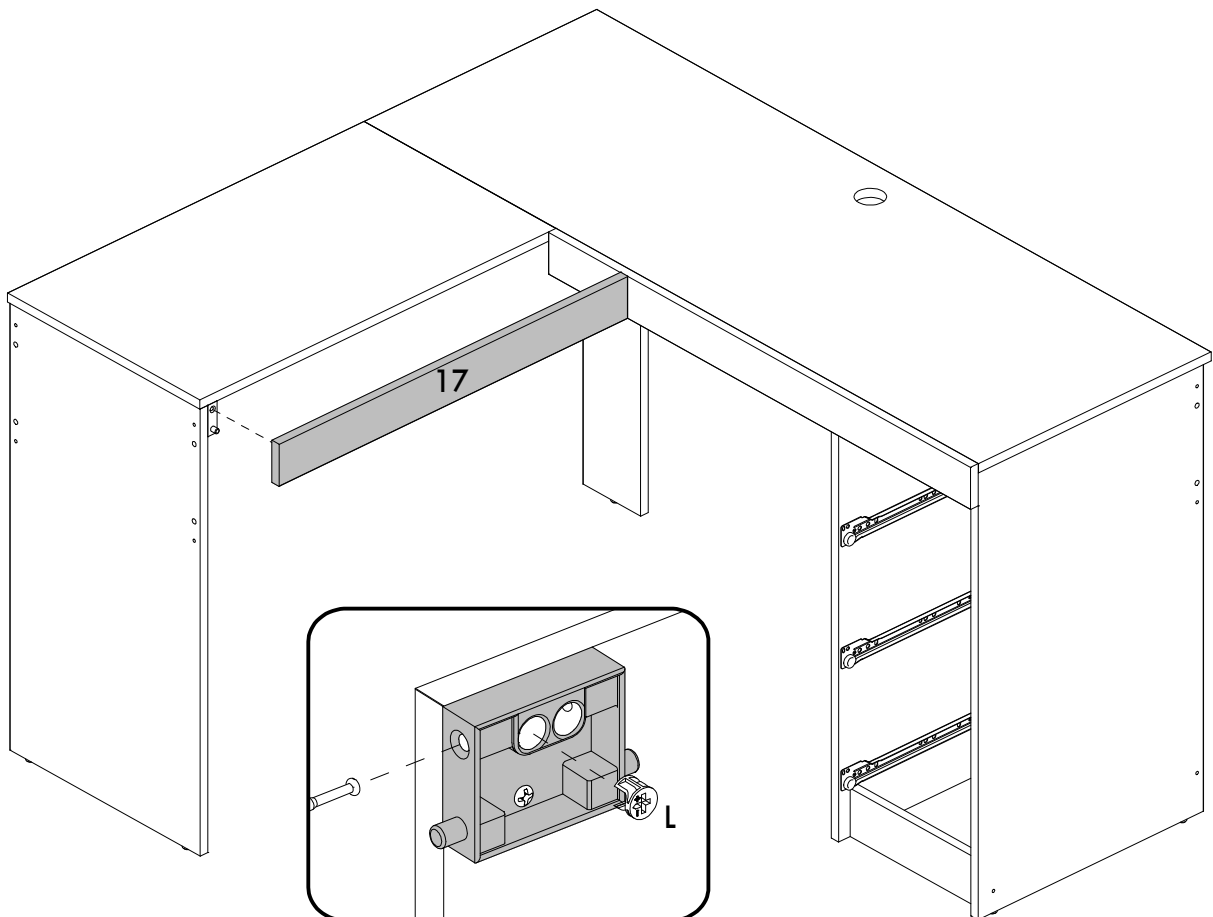

25

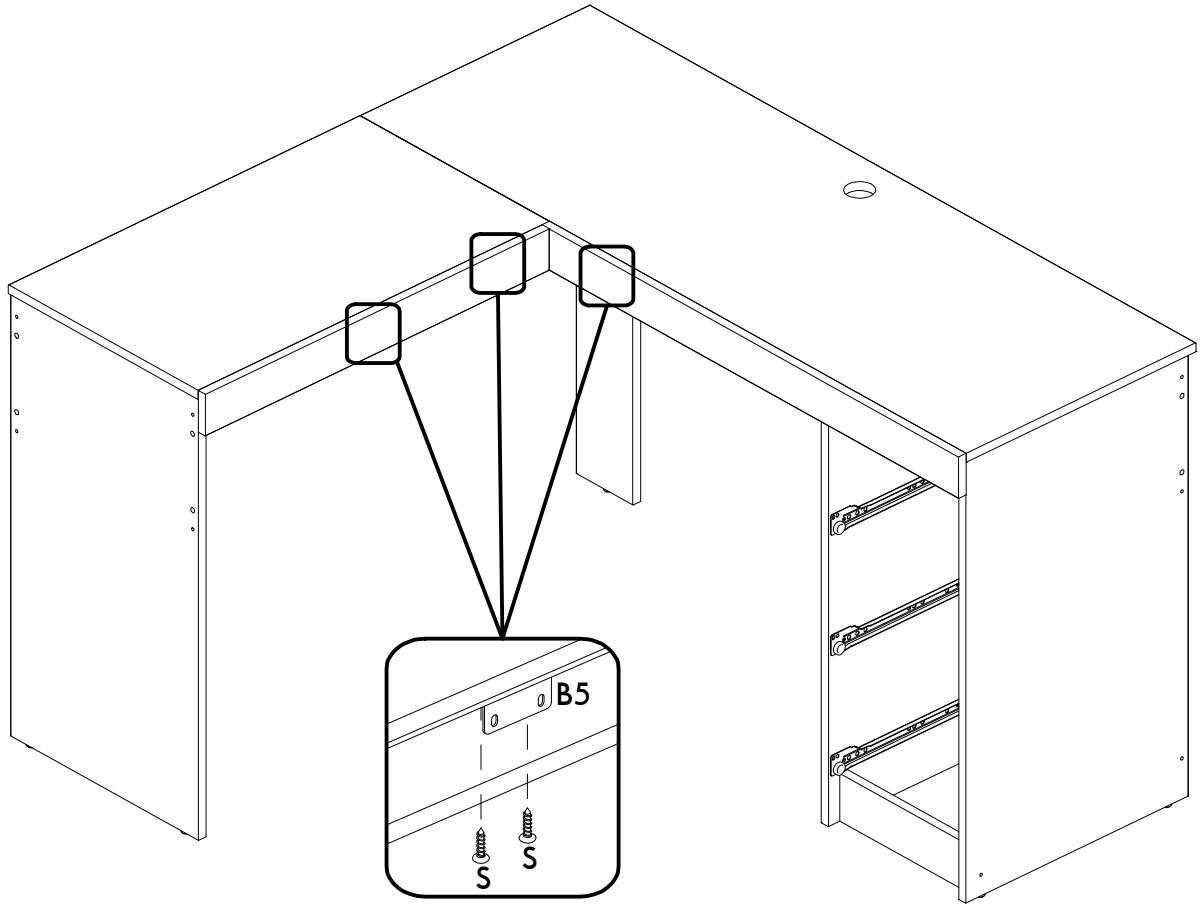

26

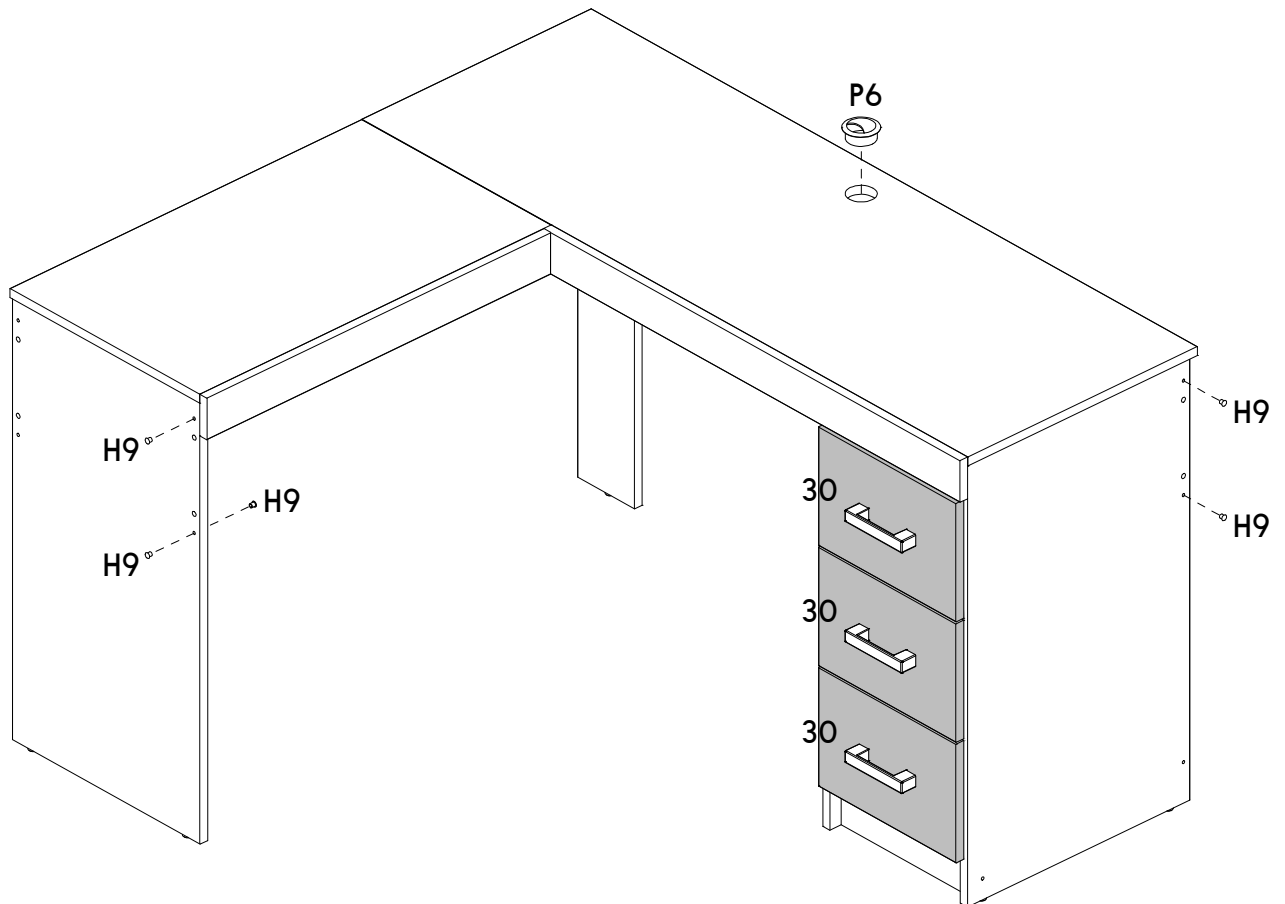

PESO MÁXIMO RECOMENDADO SENDO ESTE DISTRIBUÍDO UNIFORMEMENTE
MAXIMUM RECOMMENDED WEIGHT BEING THIS EVENLY DISTRIBUTED / PESO MÁXIMO RECOMENDADO SIENDO ESTE UNIFORMEMENTE DISTRIBUIDO

	KG	LB
A	20	44
B	10	22
C	4	9

