



**JCM**  
movelaria

# Mesa lara lara Desk Escritoriolara



Indicamos que a montagem dos produtos seja realizada com parafusadeira eléctrica e por um montador profissional.  
**We recommend that the product assembly be performed with a cordless screwdriver and by a professional furniture assembler.**  
*Se recomienda que el montaje de los productos sea realizado con un destornillador eléctrico y por un montador de muebles profesional.*

**AVISO:** Não nos comprometemos pelo mal-uso, montagem e fixação do produto à parede. Portanto, não somos responsáveis por danos e quedas do produto, eletrônicos e pertences neles contidos. É importante o uso de brocas e ferramentas compatíveis na montagem.  
**ATTENTION:** We are not responsible for misuse, assembly and wall fixation. Therefore, we are not responsible for damages and falls caused to the product, electronics and belongings therein. It is important to use suitable drills and tools for the assembly.  
**ATENCIÓN:** No nos responsabilizamos del mal uso, montaje y fijación del producto a la pared. Por lo tanto, no somos responsables de daños y caídas del producto, electrónicos y objetos que contiene. Es importante el uso de taladros y herramientas compatibles con el montaje.

Dica: Para evitar possíveis avarias, use a embalagem do produto como apoio durante a montagem.

**Tip: To avoid damages, use the product packaging as base during the assembly.**









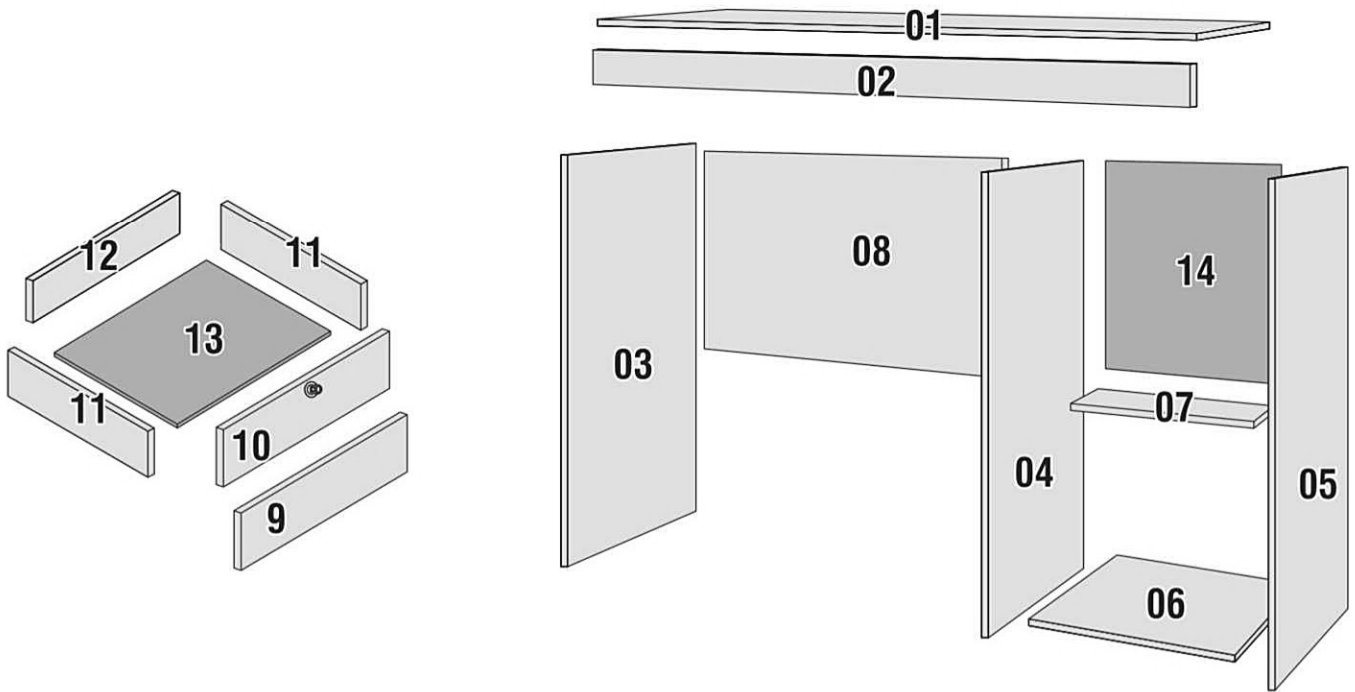





*Pista: Para evitar daños, use el envase del producto como apoyo durante el montaje.*

## RELAÇÃO DE FERRAGENS | HARDWARE LIST | LISTADO DE HERRAJES

CANTONEIRA 4 FUROS	(A)	4-HOLE ANGLE BRACKET	(A)	ÁNGULO REFUERZO 4 AGUJEROS	(A)		04
CAVILHA 6x30	(B)	6x30 DOWEL	(B)	CLAVIJA 6x30	(B)		12
KIT FECHADURA	(C)	LOCK	(C)	CERRADURA	(C)		01
PARAFUSO 3,5x14	(D)	3.5x14 SCREW	(D)	TORNILLO 3,5x14	(D)		38
PARAFUSO 3,5x14 FLANGEADO	(E)	3.5x14 FLANGE SCREW	(E)	TORNILLO FLANGEADO 3,5x14	(E)		10
PARAFUSO 3,5x30 FLANGEADO	(F)	3.5x30 FLANGE SCREW	(F)	TORNILLO FLANGEADO 3,5x30	(F)		04
PARAFUSO CORREDIÇA 6x8	(G)	6x8 SCREW	(G)	TORNILLO 6x8	(G)		08
PARAFUSO 5x40	(H)	5x40 SCREW	(H)	TORNILLO 5x40	(H)		16
PARAFUSO MINIFIX	(I)	MINIFIX BOLT	(I)	PERNO MINIFIX	(I)		06
PREGO 8x8	(J)	8x8 NAIL	(J)	CLAVO 8x8	(J)		30
PUXADOR	(K)	HANDLE	(K)	TIRADOR	(K)		02
SAPATA DESLIZANTE	(L)	SLIDING FOOT	(L)	PATA DESLIZANTE	(L)		06
SUPORTE ANGULAR	(M)	CORNER CONNECTOR	(M)	SOPORTE ANGULAR	(M)		05
TAMBOR MINIFIX	(N)	MINIFIX NUT	(N)	TUERCA MINIFIX	(N)		06

RELAÇÃO DE PEÇAS | PARTS LIST | LISTADO DE PARTES



	<b>01</b> Tampo Top Tapa	1Pc		<b>08</b> Painel Traseiro Back Panel panel trasero	1Pc
	<b>02</b> Vista Superior Top Frame Moldura Superior	1Pc		<b>9</b> Frente Gaveta Drawer Front Frente Cajón	1Pc
	<b>03</b> Lateral Esquerda Left Panel Lateral Izquierdo	1Pc		<b>10</b> Frente Gaveta com Furo Drawer Front With Hole Frente Cajón com Hueco	1Pc
	<b>04</b> Divisão Division División	1Pc		<b>11</b> Lateral Gaveta Drawer Side Lateral Cajón	4Pcs
	<b>05</b> Lateral Direita Right Panel Lateral Derecho	1Pc		<b>12</b> Traeiro Gaveta Drawer Back Trasero Cajón	2Pcs
	<b>06</b> Prateleira Inferior Bottom Shelf Estante Inferior	1Pc		<b>13</b> Fundo Gaveta Drawer Bottom Fondo Cajón	2Pcs
	<b>07</b> Prateleira Central Middle Shelf Estante Central	1Pc		<b>14</b> Costas Back Trasera	1Pc

Passo 01 PARAFUSE A PEÇA 2 NA PEÇA 1 COM SUPORTE ANGULAR(M) E PARAFUSO 3,5x14 FLANGEADO(E).

Step 01 SCREW PART 2 INTO PART 1 WITH CORNER CONNECTOR (M) AND 3.5x14 FLANGE SCREW (E).

Paso 01 ATORNILLE LA PARTE 2 A LA PARTE 1 CON SOPORTE ANGULAR (M) Y TORNILLO FLANGEADO 3,5x14 (E).

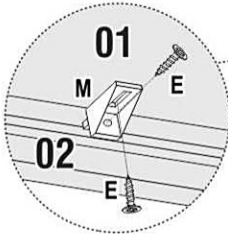
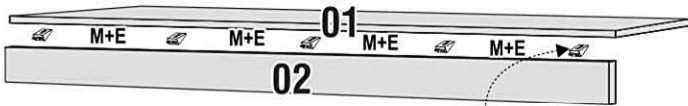

E = 5 

M = 5 

VISTA FRONTAL  
FRONT VIEW  
VISTA FRONTAL

Passo 02 ENCAIXE E FIXE AS LATERAIS 3 E 5 NA PEÇA 1 COM MINIFIX (I+N) COLOCANDO AS SAPATAS DESLIZANTES(L+D) NAS MESMAS.

Step 02 FASTEN SIDE PANELS 3 AND 5 TO PART 1 WITH MINIFIX (I+N) AND SCREW THE FEET (L+D).

Paso 02 ENCAJE LOS LATERALES 3 Y 5 EN LA PARTE 1 CON MINIFIX (I+N) Y ATORNILLE LAS PATAS (L+D).

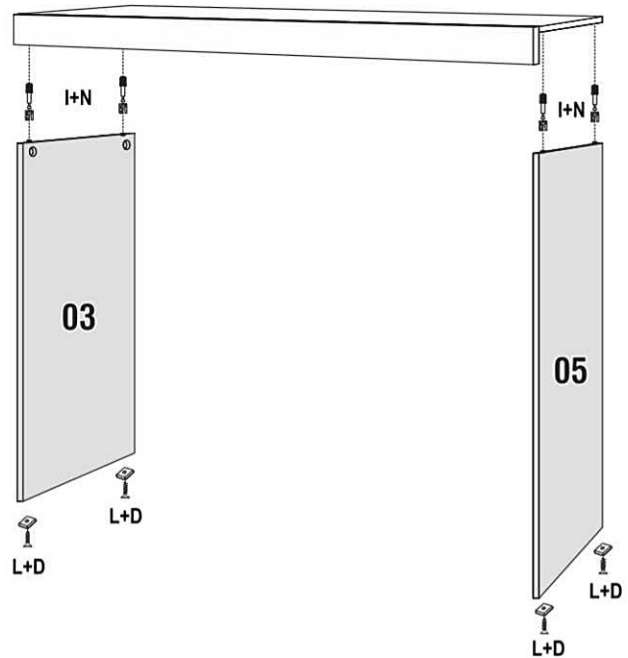

D = 4 

L = 4 

I = 4 

N = 4 



VISTA FRONTAL  
FRONT VIEW  
VISTA FRONTAL

Passo 03 ENCAIXE E FIXE A DIVISÃO 4 NA PEÇA 1 COM MINIFIX (I+N), JÁ COLOCANDO AS SAPATAS (L+D) E AS CORREDIÇAS COM PARAFUSOS 6x8 (G).

Step 03 FASTEN THE DIVISION 4 TO PART 1 WITH MINIFIX (I+N), SCREW THE FEET (L+D) AND THE SLIDES WITH 6x8 SCREW (G).

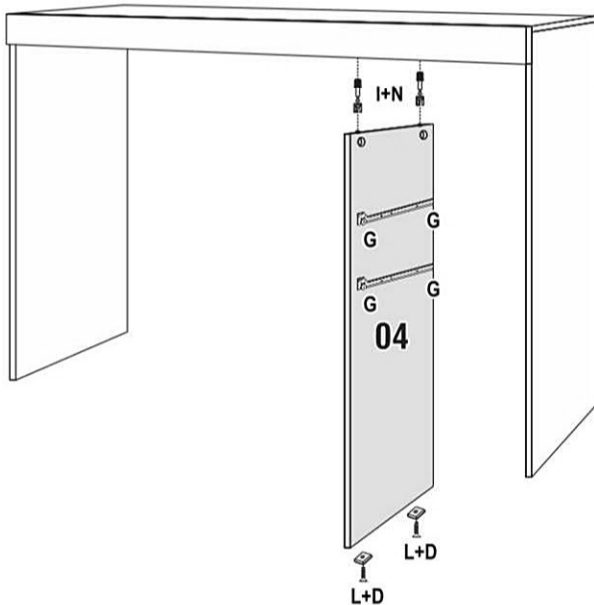
Paso 03 ENCAJE LA DIVISION 4 A LA PARTE 1 CON MINIFIX (I+N). ATORNILLE LAS PATAS (L+D) Y LAS CORREDERAS CON TORNILLO 6x8 (G).



D = 2  L = 2  G = 4 

I = 2  N = 2 

VISTA FRONTAL  
FRONT VIEW  
VISTA FRONTAL

Passo 04 PARAFUSE A PEÇA 8 NAS PEÇAS 3 E 4 COM PARAFUSO PARAF. 5x40 (H).

Step 04 SCREW PART 8 INTO PARTS 3 AND 4 WITH 5x40 SCREW (H).

Paso 04 ATORNILLE LA PARTE 8 A LAS PARTES 3 Y 4 CON TORNILLO 5x40 (H).

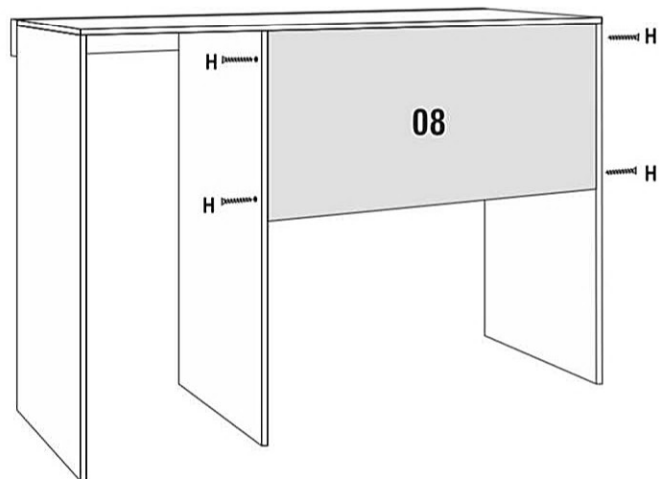

H = 4 

VISTA TRASEIRA  
BACK VIEW  
VISTA TRASERA

Passo 05 PARAFUSE AS PEÇAS 6 E 7 NAS PEÇAS 4 E 5 COM PARAFUSO 5x40(H).  
 Step 05 SCREW PARTS 6 AND 7 INTO PARTS 4 AND 5 WITH 5x40 SCREW (H).  
 Paso 05 ATORNILLE LAS PARTES 6 Y 7 A LAS PARTES 4 Y 5 CON TORNILLO 5x40 (H).

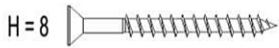
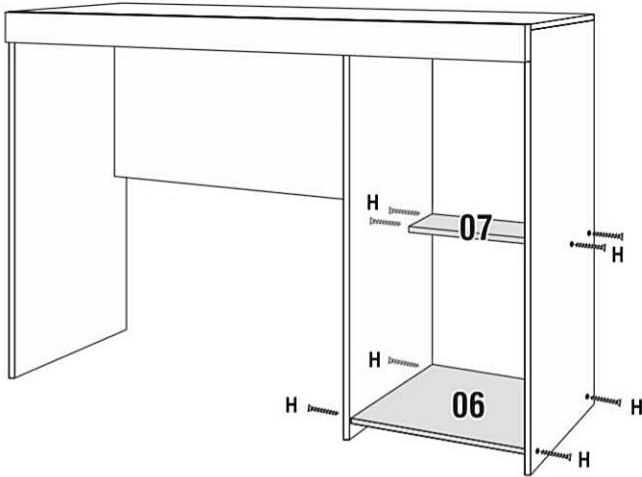

VISTA FRONTAL  
 FRONT VIEW  
 VISTA FRONTAL

Passo 06 PREGUE AS COSTAS COM PREGO 8x8 (J) CONFORME DESENHOS A BAIXO.  
 Step 06 FASTEN THE BACK WITH 8x8 NAIL (J) ACCORDING TO THE PICTURE.  
 Paso 06 FIJE LA TRASERA CON CLAVO 8x8 (J) SEGÚN EL DISEÑO ABAJO.

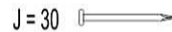
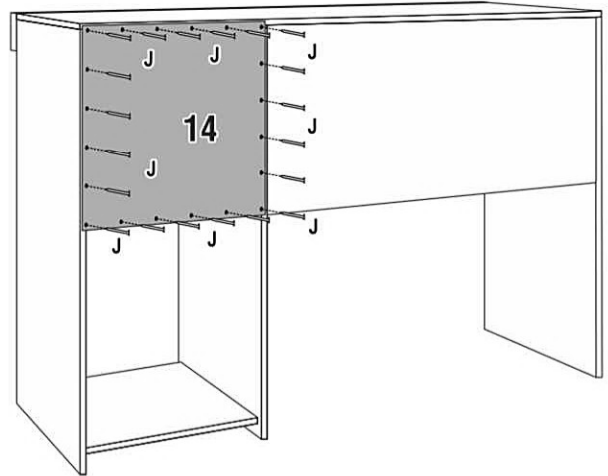

VISTA TRASEIRA  
 BACK VIEW  
 VISTA TRASERA

Passo 07 MONTE AS GAVETAS COM SUAS RESPECTIVAS FERRAGENS.  
 Step 07 ASSEMBLE THE DRAWERS WITH THEIR HARDWARE.  
 Paso 07 MONTE LOS CAJONES CON SUS HERRAJES.

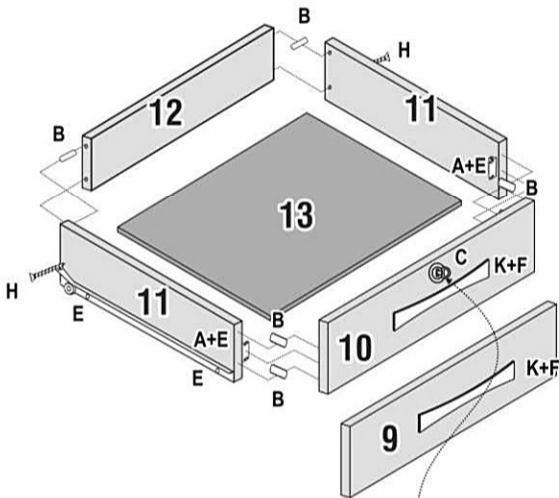

- A=4
- B=12
- C=1
- D=24
- F=4
- H=4
- K=2

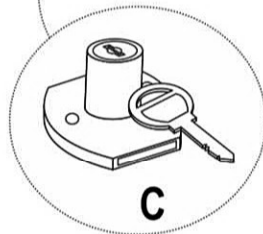

VISTA FRONTAL  
 FRONT VIEW  
 VISTA FRONTAL

Passo 08 COLOQUE AS GAVETAS NA MESA JÁ MONTADA.  
 Step 08 INSERT THE DRAWERS ALREADY ASSEMBLED.  
 Paso 08 PONGA LOS CAJONES YA MONTADOS.

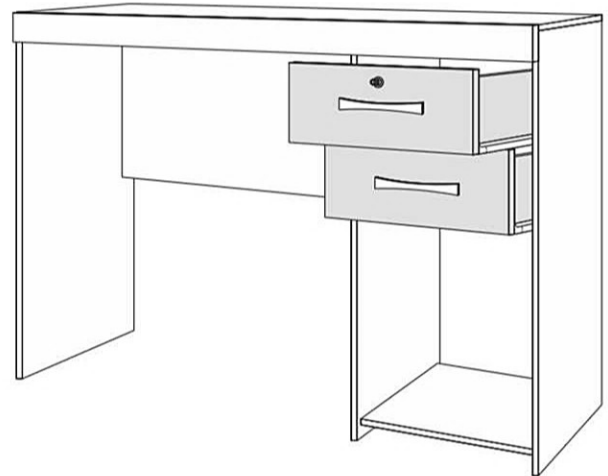

VISTA FRONTAL  
 FRONT VIEW  
 VISTA FRONTAL