

Escrevaninha Next

Escritorio Next

Next Desk

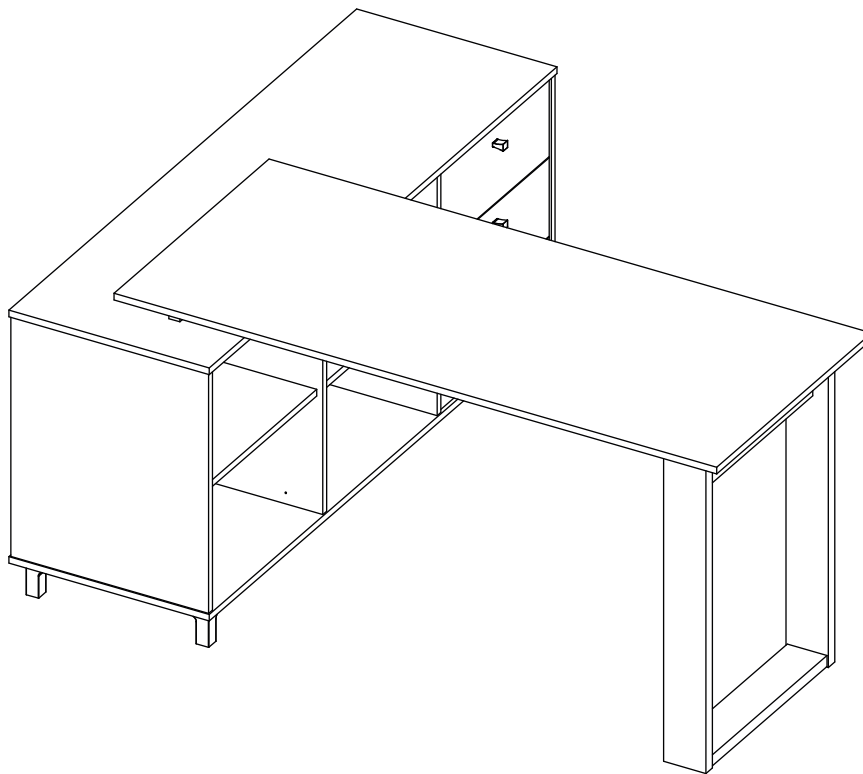
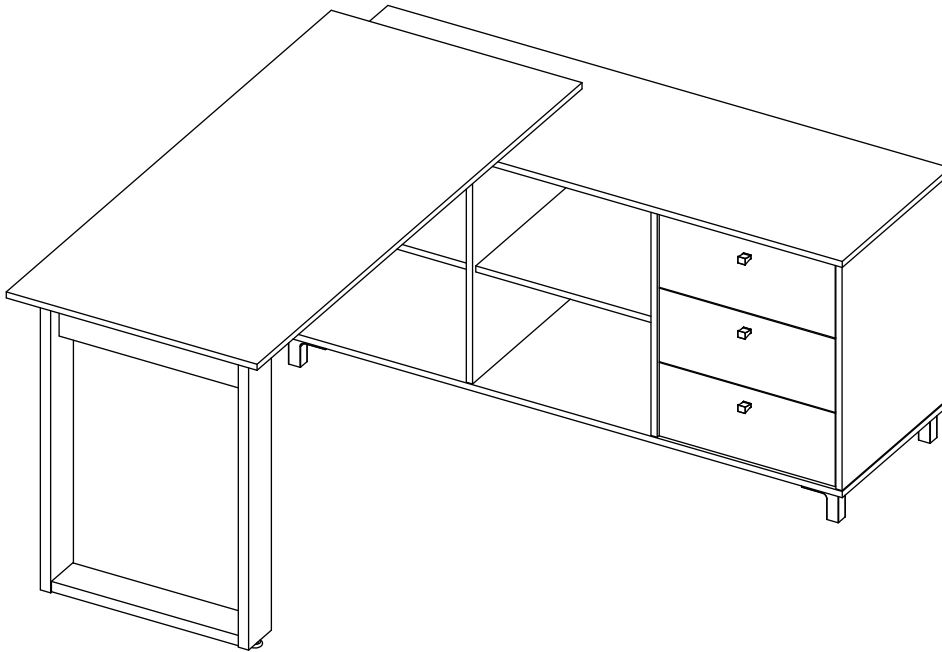

ARTANY[®]
Arte em Home Office

Conheça outros produtos da nossa empresa no site: www.artany.com.br

Conozca otros productos en el sitio: www.artany.com.br

Know another products in: www.artany.com.br

- Siga atentamente todas as instruções de montagem;
- Monte seu produto no local ou próximo de onde será colocado. Movimentações do produto já montado, podem avariá-lo;
- Faça a montagem em uma superfície limpa e plana. Aconselhamos usar a própria embalagem de papelão para forrar o chão;
- Verifique se as quantidades de peças e acessórios estão de acordo com o manual de montagem;
- Compare atentamente os furos de cada peça com a ilustração do manual;
- Utilize as ferramentas indicadas. Só utilize parafusadeira se tiver conhecimento e habilidade. O uso inapropriado pode danificar peças e/ou acessórios;
- Se o produto necessitar fixação na parede, tenha cuidado para não atingir fios e canos ao furar a parede.

Obs: Caso necessite solicitar peças de reposição, por favor, utilize os códigos dos mesmos.

- Siga con atención todas las instrucciones de armado.
- Arme su mueble en un lugar cerca donde será instalado. Mover el producto ya montado puede perjudicarlo.
- Haga el montaje en una superficie limpia y plana. Aconsejamos usar el propio embalaje de cartón para forrar el suelo.
- Asegúrese de que las cantidades de piezas y accesorios coincidan con el manual de montaje.
- Compare cuidadosamente los agujeros de cada pieza con la ilustración del manual.
- Utilice las herramientas indicadas. Sólo utilice atornillador automático si tiene conocimiento y habilidad. El uso inapropiado puede dañar piezas y/o accesorios.
- Si el producto necesita fijación en la pared, tenga cuidado de no alcanzar cables y tuberías al perforar la pared.

OBS: Si necesita solicitar piezas y / o accesorios de repuesto, por favor, utilice los códigos de los mismos.

- Follow carefully the assembly instructions.
- Assemble your furniture in a place near where it will be installed. Moving the assembled product can harm it.
- Make the assembly on a clean and flat surface. We recommend using the cardboard box to cover the floor.
- Make sure the quantities of parts and accessories match the assembly manual.
- Carefully compare the holes in each piece with the illustration in the manual.
- Use the indicated tools. Only use an automatic screwdriver if you have knowledge and skill. Improper use can damage parts and/or accessories.
- If the product needs fixing on the wall, be careful and don't reach cables and pipes when drilling the wall.

NOTE: If you need to request spare parts and/or accessories, please use the codes according of this instruction manual.

CONSERVAÇÃO E LIMPEZA

MANTENIMIENTO Y LIMPIEZA / MAINTENANCE AND CLEANING

Não expor o produto ao sol, altas temperaturas e umidade, mantendo-o em local seco e arejado. Para a limpeza, utilizar um pano seco e macio. Não é necessário o uso de materiais abrasivos ou álcool.

No exponga el producto al sol, altas temperaturas y la humedad. Mantener en local seco y ventilado. Para limpiar, utilice un paño suave y seco. No es necesario el uso de materiales abrasivos o alcohol.

Do not expose the product to sunlight, high temperatures and humidity. Keep it in a dry and ventilated place. To clean it, use a soft and dry cloth. It is not necessary to use abrasive materials or alcohol.

Garantia

Este certificado de Garantia é uma vantagem adicional oferecida ao consumidor, porém para que o mesmo tenha validade é imprescindível que seja apresentada a NOTA FISCAL de compra do produto e o número do lote (ver etiqueta).

Com este produto, a **Artany** tem como objetivo atender plenamente o proprietário-consumidor, proporcionando a garantia na forma aqui estabelecida, pelo período de 03 meses a partir da data da nota fiscal de compra. A **Artany** restringe a sua responsabilidade à substituição gratuita das peças defeituosas, em caso de defeitos ou avarias devidamente constatados como sendo de fabricação, durante a vigência desta garantia.

A **Artany** declara a garantia nula e sem efeito se o produto for alterado, adulterado, molhado ou consertado e ainda pela prática de montagem inadequada. Também será considerada nula em casos de força maior, como aqueles causados por agentes da Natureza (chuvas, incêndios, excesso de umidade...).

Para exercer seus direitos de comprador é importante que antes de montar seu produto você leia com atenção as instruções de cada passo do manual de montagem que acompanha o móvel.

Caso o produto não esteja em conformidade, entre em contato com a loja onde efetuou a compra ou com o nosso Serviço de Atendimento ao Cliente através do fone (41) 3556-1500 ou do e-mail assistencia@artany.com.br, e faça sua reclamação, apontando os defeitos técnicos observados, que teremos o maior prazer em atendê-lo. Para agilizar o seu atendimento, tenha sempre em mãos o manual de montagem com os respectivos números das peças defeituosas conforme descritas no manual.

FERRAMENTAS **NÃO** FORNECIDAS, MAS NECESSÁRIAS
PARA A MONTAGEM DO PRODUTO

HERRAMIENTAS **NO** SUMINISTRADAS, PERO NECESARIAS PARA EL MONTAJE DEL PRODUCTO
TOOLS **NOT** SUPPLIED, BUT NECESSARY FOR THE ASSEMBLY

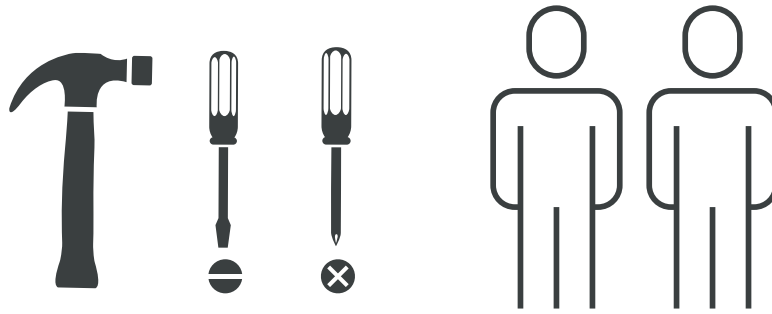

LISTA DE MATERIAIS
LISTA DE MATERIALES
HARDWARE LIST

A		Cavilha Tarugo Dowel Ø6x30mm	36x	I	I ₁		Puxador Tirador Handle 24x18x16mm	3x
B		Minifix Minifix Minifix Ø7x32mm	40x		I ₂		Parafuso Tornillo Screw	
C		Tambor Tambor Minifix Cam Ø15x12mm	40x	J Corrediça Guia / Slider 350mm	J ₁		Esquerda Izquierda Left	3x
D		Tapa furo adesivo Adhesivo Hole Cover Ø18mm	36x		J ₂		Esquerda Izquierda Left	
E		Parafuso / Tornillo / Screw Ø3,5x40mm CP	9x		J ₃		Direita Derecha Right	
F		Parafuso / Tornillo / Screw Ø4,0x30mm CP	5x		J ₄		Direita Derecha Right	
G		Parafuso / Tornillo / Screw Ø4,0x16mm CP	10x	K		Bucha sapata Buje pata Foot bushing	2x	
H		Parafuso / Tornillo / Screw Ø3,5x12mm CC	30x	L		Sapata Pata Foot	2x	
				M		Sapata Quadrada Pata Cuadrada Square Foot	5x	

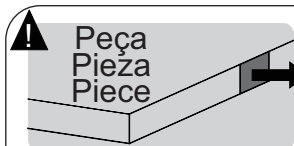

Cor da borda
Color del borde
Edge color

Azul (Lateral dir.)
Vermelho (Lateral esq.)
Preto (Divisão dir.)
Verde (Divisão esq.)

Azul (Lateral derecho)
Rojo (Lateral izquierda)
Negro (División derecha)
Verde (División izquierda)

Blue (Right side)
Red (Left side)
Black (Right partition)
Green (Left partition)

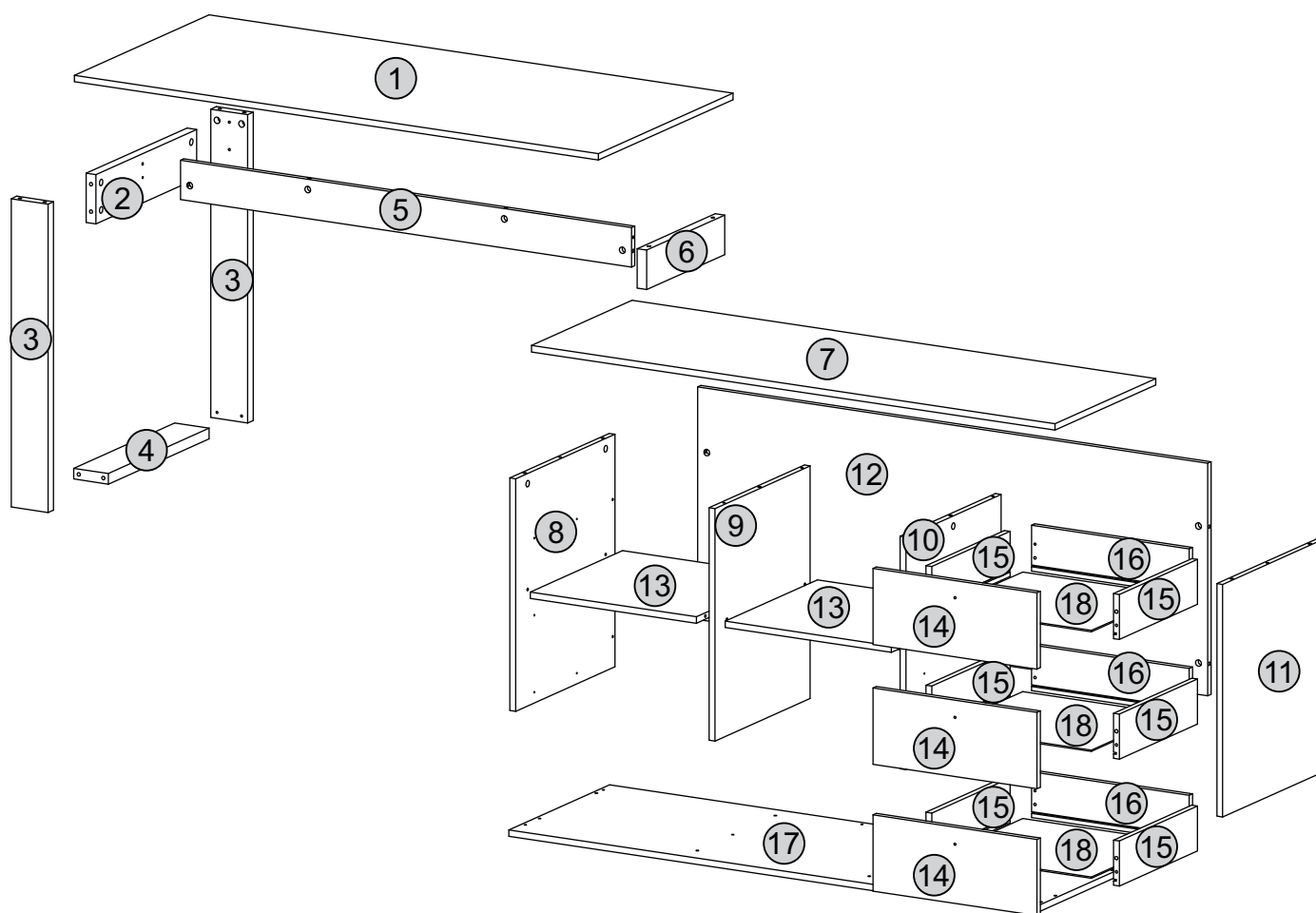

Descrição	Descripción	Description	Qty
1-Tampo (1365x608x15mm)	1-Top	1-Top	1
2-Travessa superior (455x115x25mm)	2-Travesaño superior	2-Upper crosspiece	1
3-Lateral pé (720x96x25mm)	3-Pie lateral	3-Side foot	2
4-Travessa inferior (455x90x25mm)	4-Travesaño inferior	4-Bottom crosspiece	1
5-Travessa (1175x92x15mm)	5-Travesaño	5-Crosspiece	1
6-Travessa balcão (352x92x25mm)	6-Travesaño balcón	6-Cabinet crosspiece	1
7-Tampo balcão (1364x454x15mm)	7-Top balcón	7-Cabinet top	1
8-Lateral esquerda (543x448x15mm)	8-Lado izquierdo	8-Left side	1
9-Divisão esquerda (543x430x15mm)	9-División izquierda	9-Left division	1
10-Divisão direita (543x430x15mm)	10-División derecha	10-Right division	1
11-Lateral direita (543x448x15mm)	11-Lado derecho	11-Right side	1
12-Traseira (1329x543x15mm)	12-Trasero	12-Back	1
13-Prateleira (433x416x15mm)	13-Anaqueil	13-Shelf	2
14-Frente gaveta (427x178x15mm)	14-Frontal cajón	14-Drawer front	3
15-Lateral gaveta (353x105x15mm)	15-Lado cajón	15-Drawer side	6
16-Traseira gaveta (408x107x15mm)	16-Trasero del Cajón	16-Drawer back	3
17-Base (1364x454x15mm)	17-Base	17-Base	1
18-Fundo gaveta (364x389x3mm)	18-Fundo del Cajón	18-Drawer bottom	3

1 **Você pode montar sua Escrivaninha Next do jeito que mais se adequar ao seu ambiente!**
Puede montar tu Escritorio Next de la forma que mejor se adapte a su entorno!
You can assemble your Next Desk in the way that best suits your environment!

2 **As gavetas podem ser montadas:**
Los cajones se pueden montar:
The drawers can be assembled:

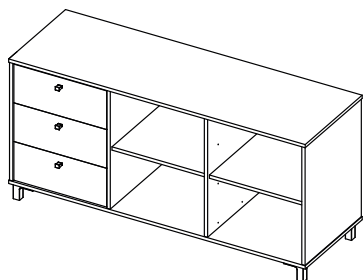

No lado esquerdo
En el lado izquierdo
On the left side

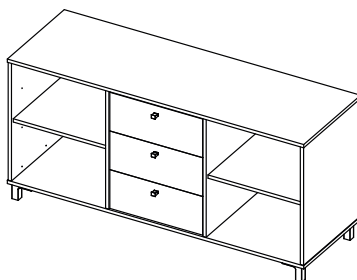

No meio
En el centro
In the middle

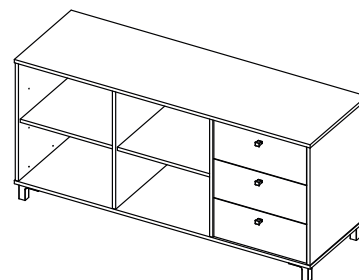

No lado direito
En el lado derecho
On the right side

3 **Já a mesa, pode ser montada:**
La mesa, se puede montar:
The table, on the other hand, can be assembled:

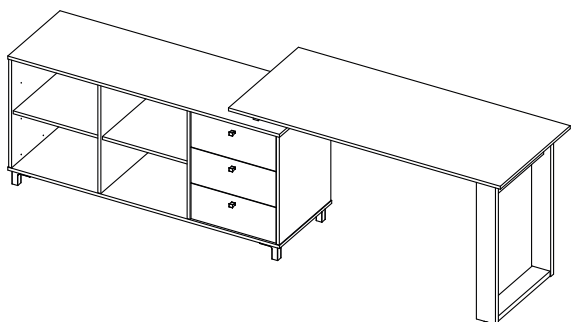

Reta com o balcão à esquerda
Recto con el balcón a la izquierda
Straight with the cabinet on the left

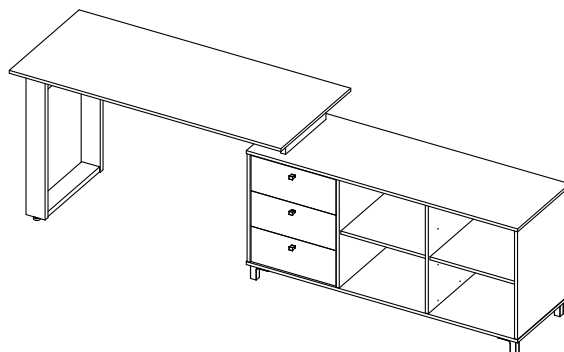

Reta com o balcão à direita
Recto con el balcón a la derecha
Straight with the cabinet on the right

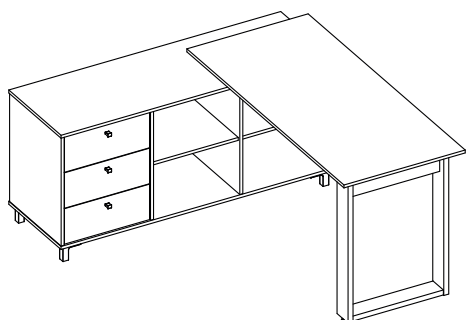

Em "L" com o balcão à esquerda
En forma de L con el balcón a la izquierda
L-shaped with the cabinet on the left

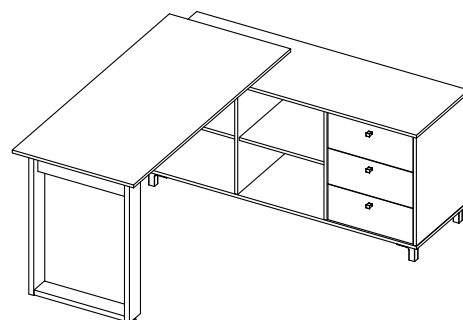

Em "L" com o balcão à direita
En forma de L con el balcón a la derecha
L-shaped with the cabinet on the right

4

Isso gera diversas possibilidades para que seu ambiente fique com o móvel perfeito para ele, pois você merece o melhor!
Esto genera varias posibilidades para que tu entorno tenga el mobiliario perfecto para él, ¡porque te mereces lo mejor!
This allows several possibilities for your ambience to have the perfect furniture for it, because you deserve the best!



Escolha a opção de montagem e, quando indicado, siga atentamente a montagem do símbolo correspondente.

Elija la opción de montaje y, cuando se indique, siga cuidadosamente el montaje del símbolo correspondiente.

Choose the assembly option and, when indicated, carefully follow the assembly of the corresponding symbol.

1

Linear esquerda

Lineal izquierda

Left linear

1A

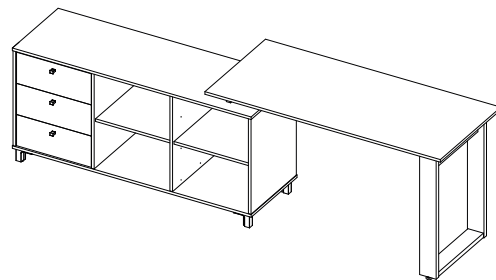

1B

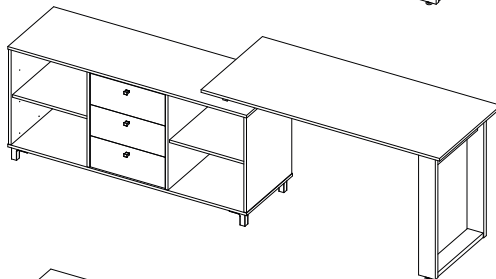

1C

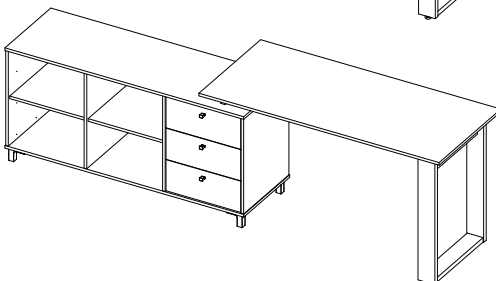

2

Linear direita

Lineal derecha

Right linear

2A

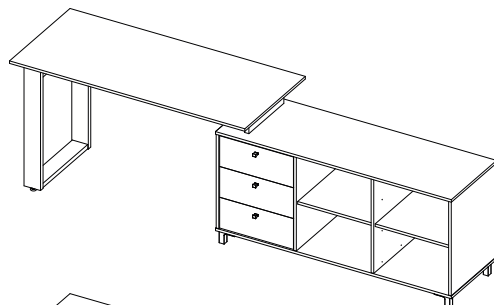

2B

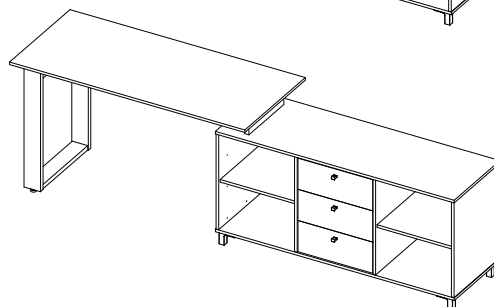

2C

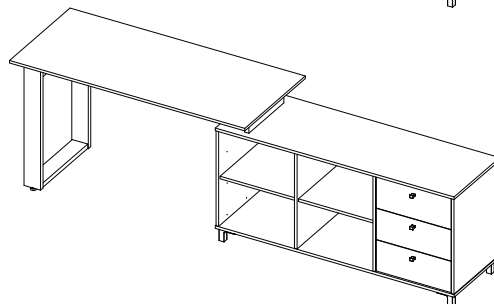



Escolha a opção de montagem e, quando indicado, siga atentamente a montagem do símbolo correspondente.

Elija la opción de montaje y, cuando se indique, siga cuidadosamente el montaje del símbolo correspondiente.

Choose the assembly option and, when indicated, carefully follow the assembly of the corresponding symbol.

3 **Lado esquerdo**
Lado izquierdo
Left side

3A

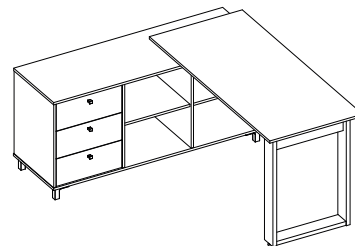

3B

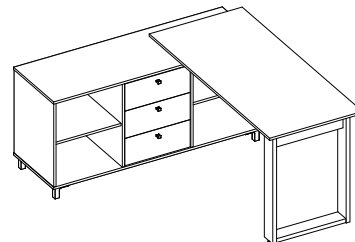

3C

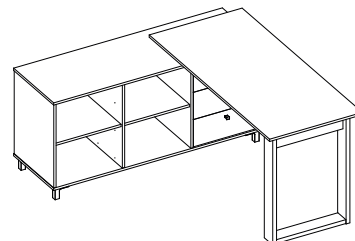

4 **Lado direito**
Lado derecho
Right side

4A

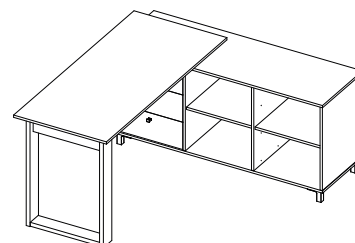

4B

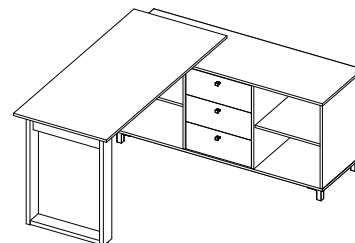

4C

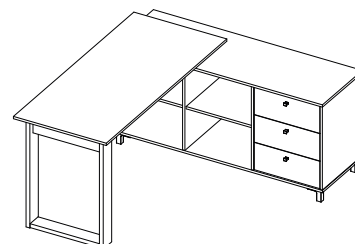

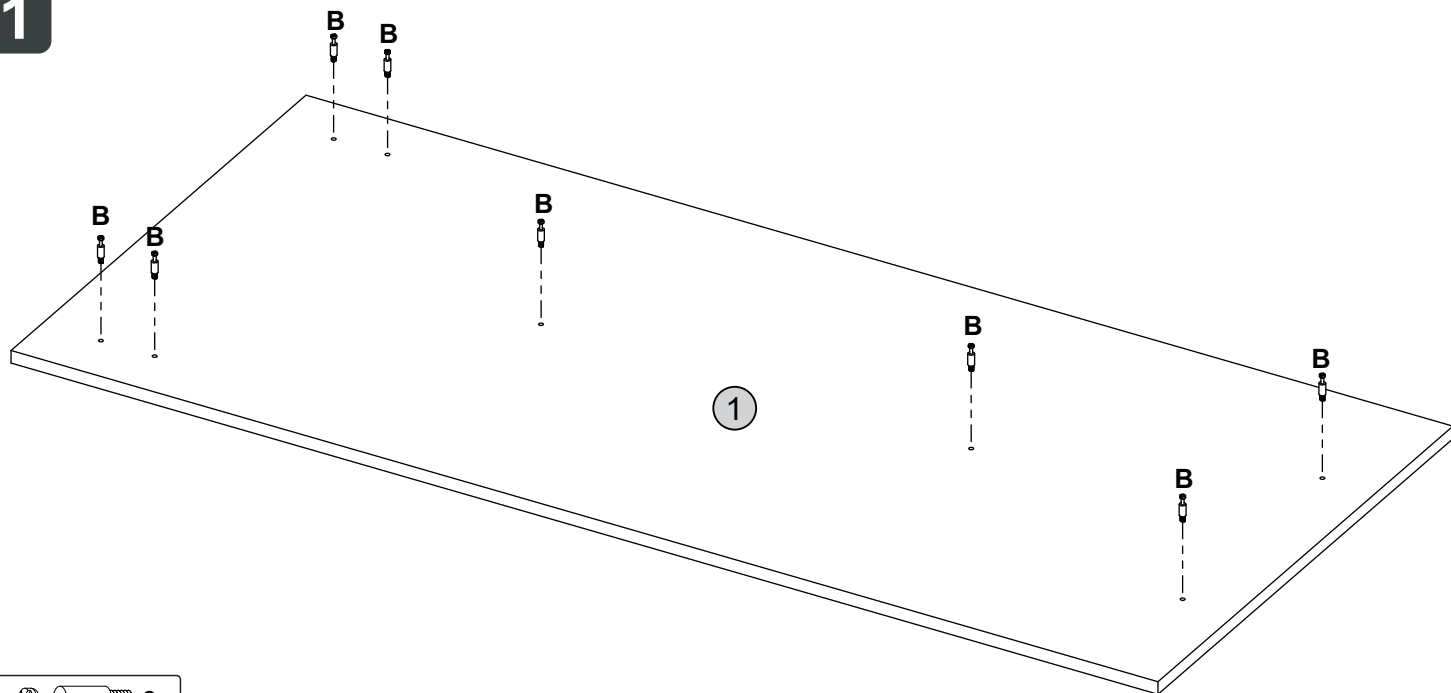

1

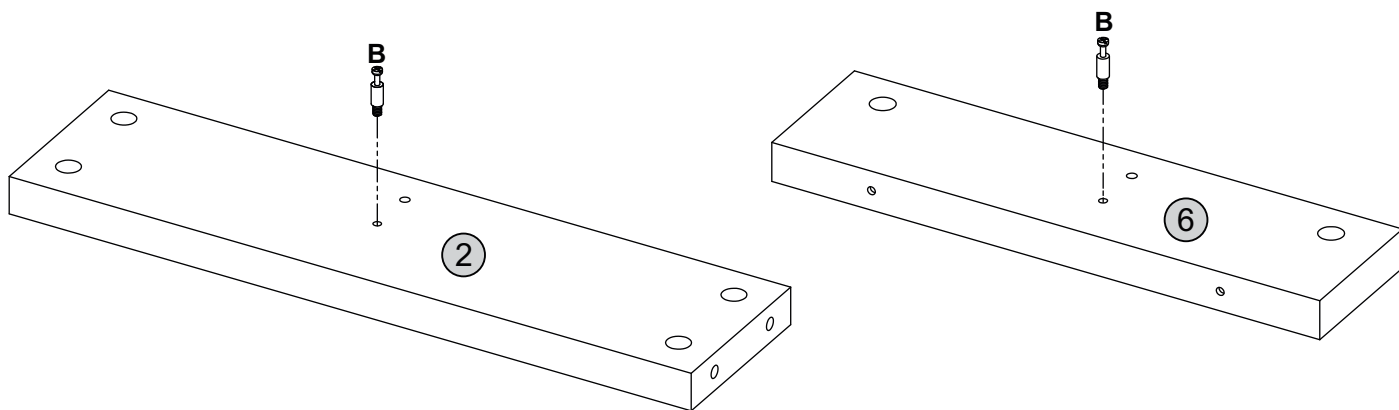

B  8x

2



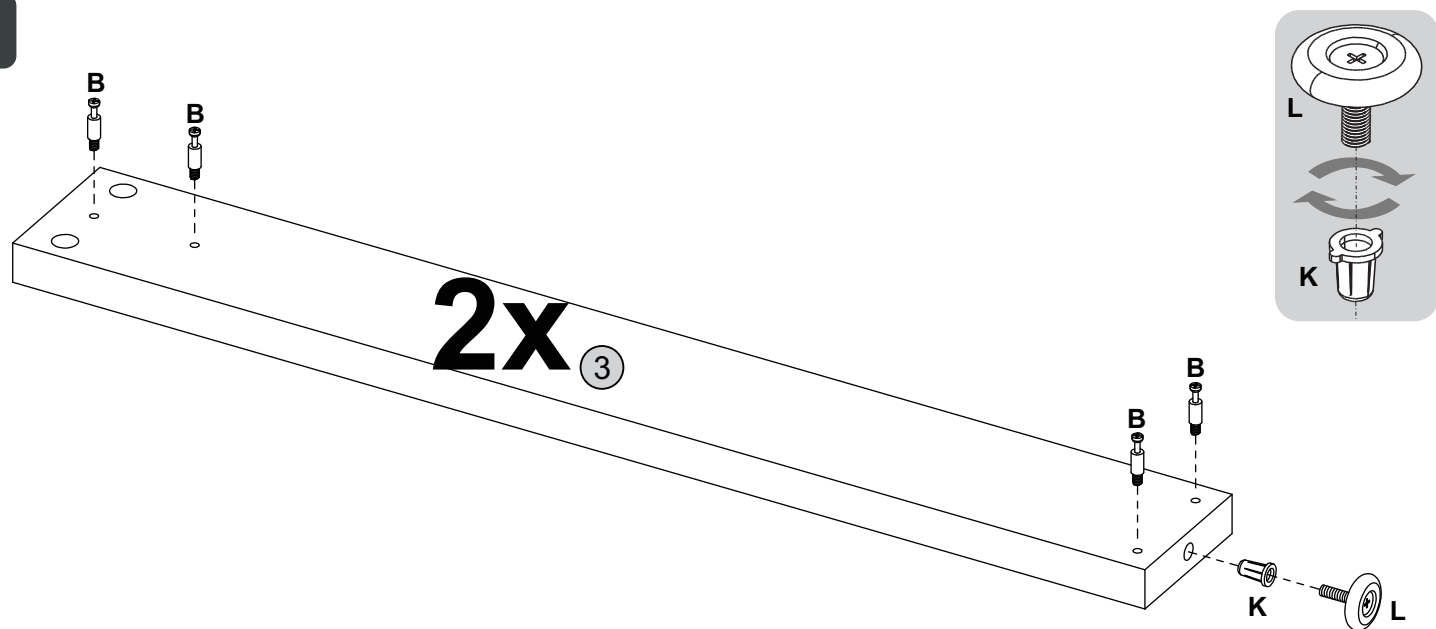

B  2x

3





B  8x

K  2x

L  2x

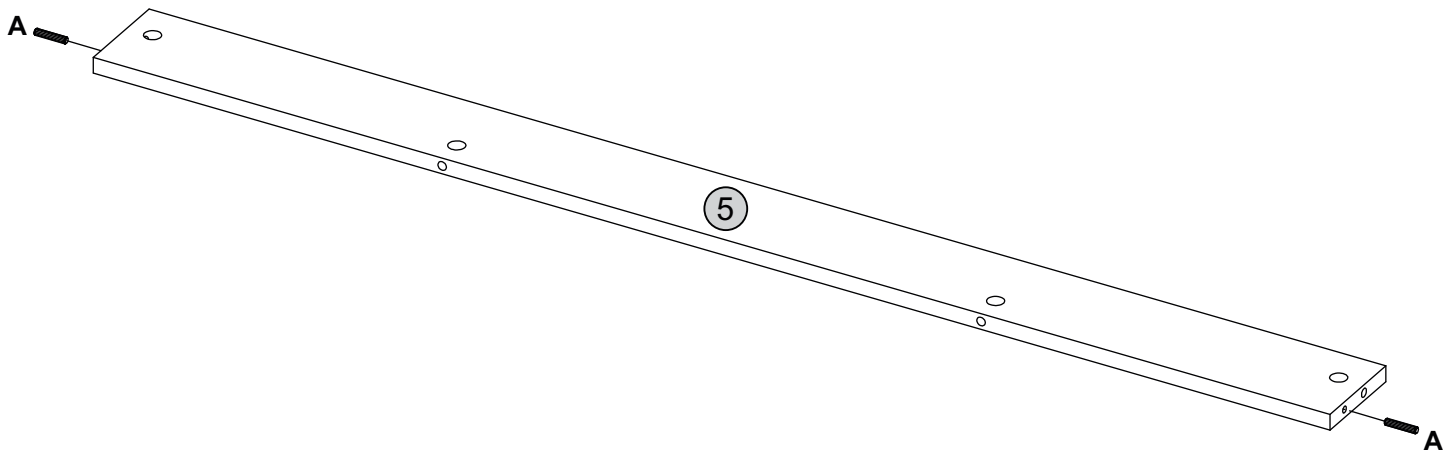
4



A  2x

5

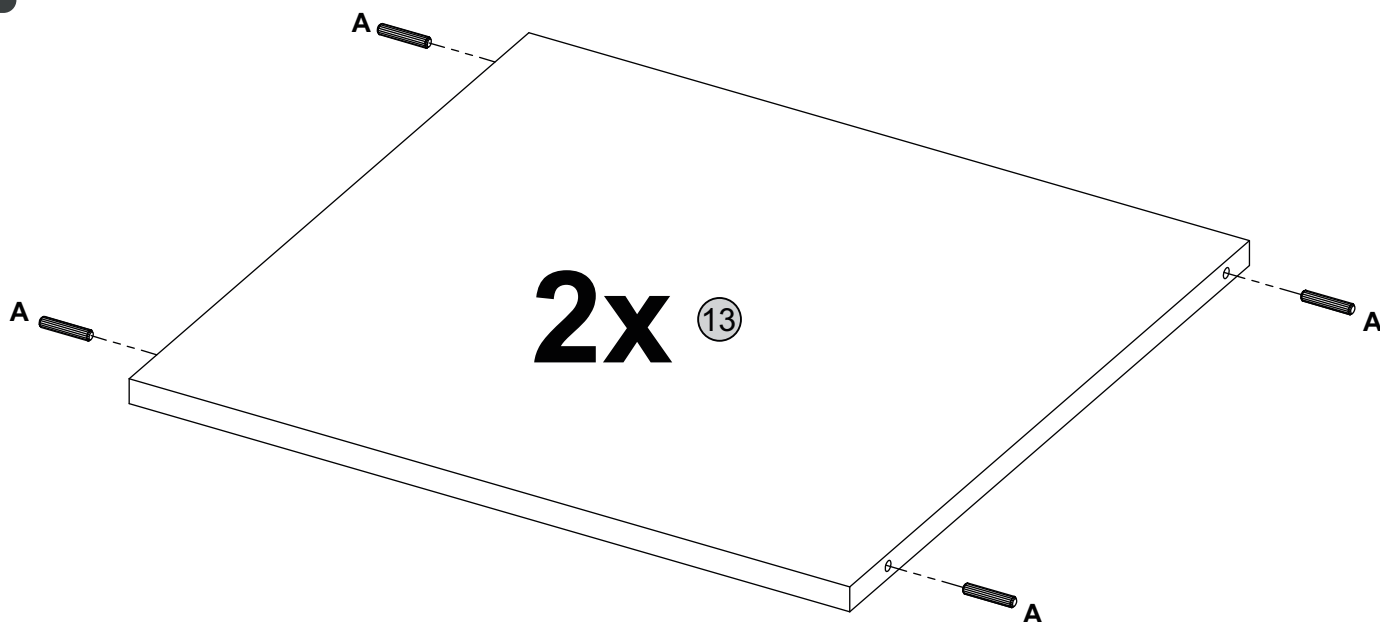

A  8x

6

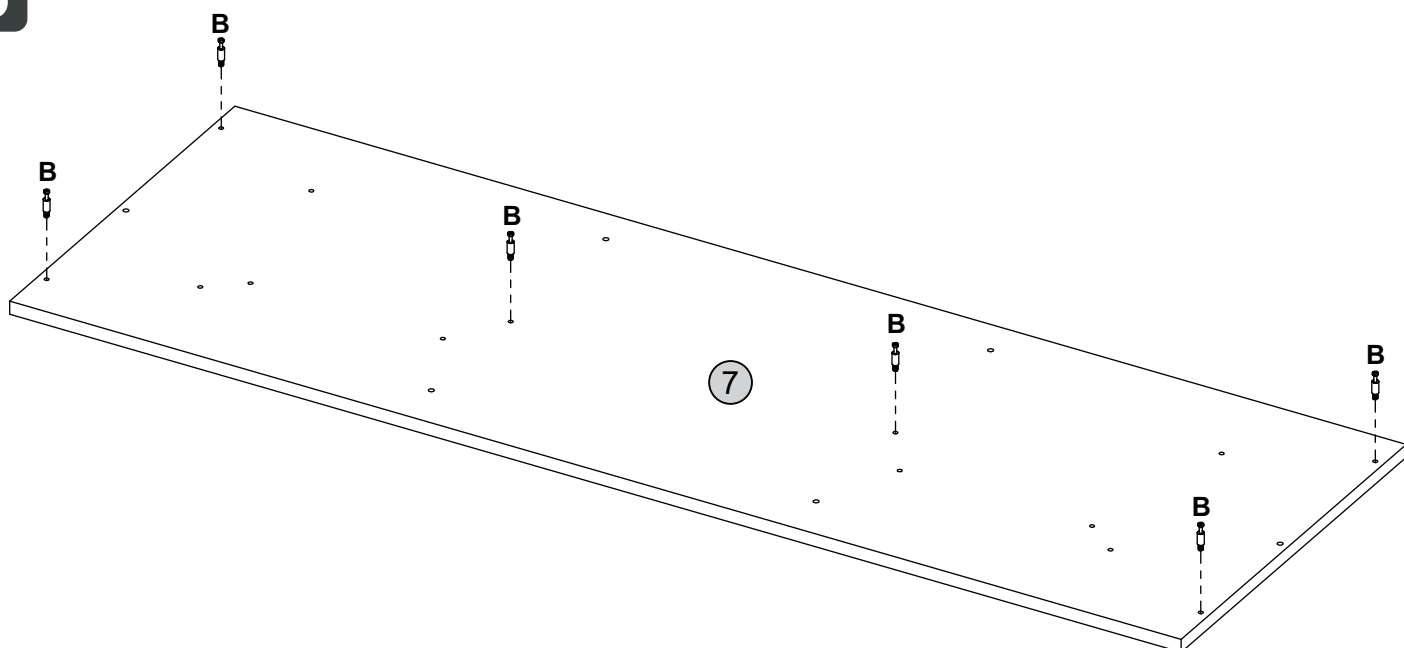

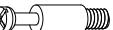
B  6x

7

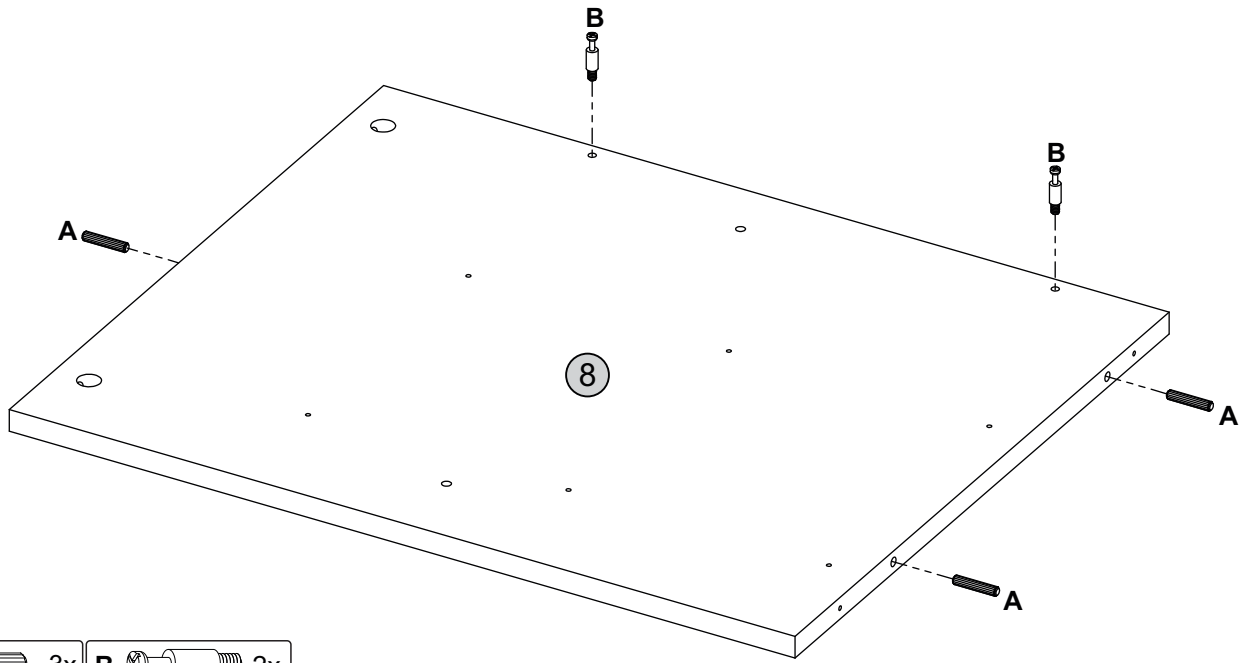

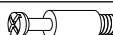
- A  3x
- B  2x

8

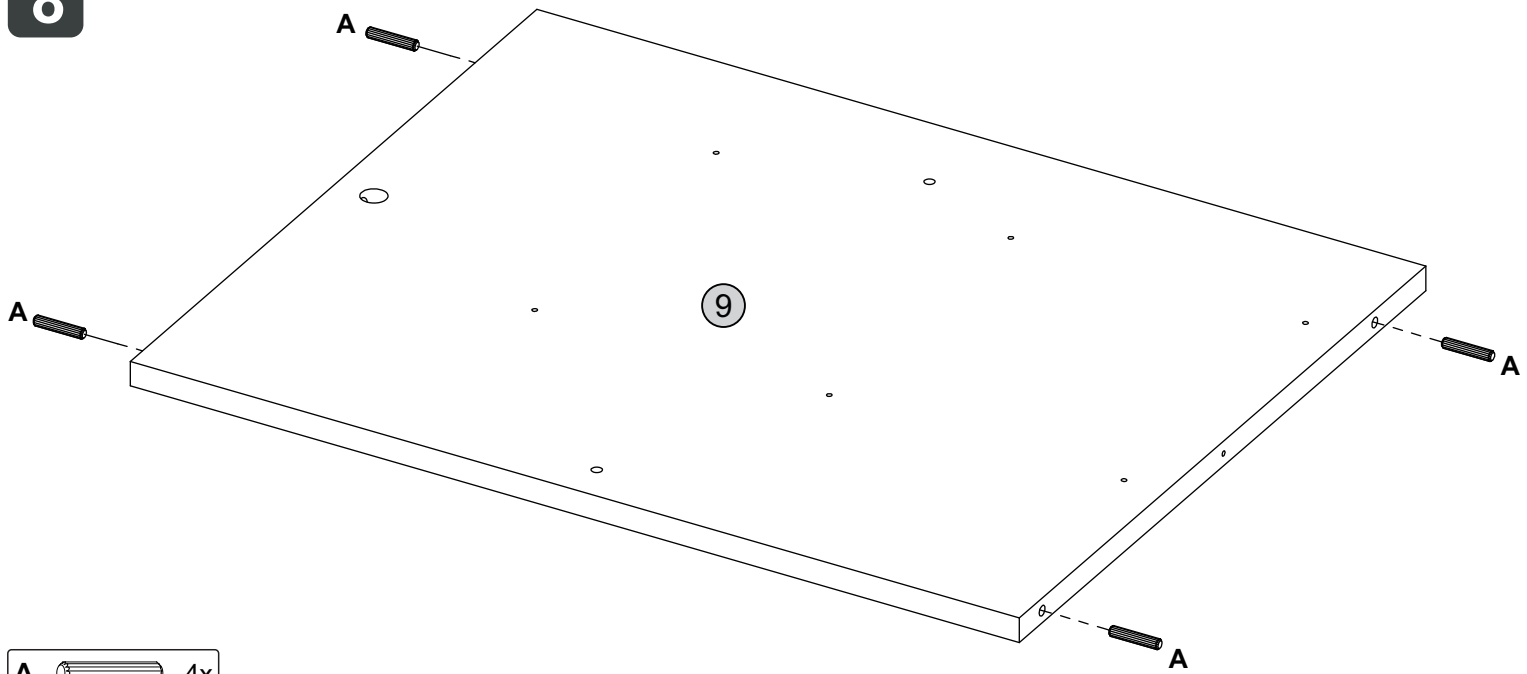

- A  4x

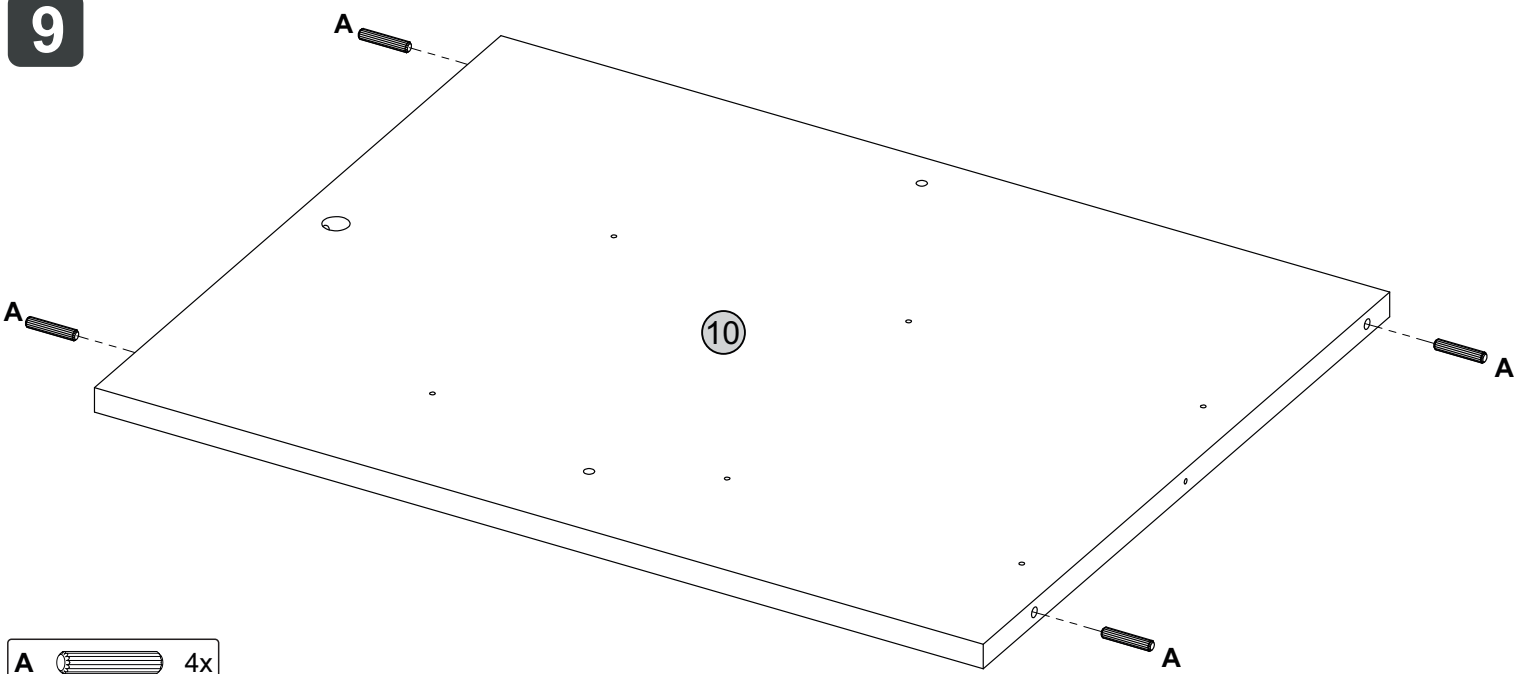

9



- A  4x

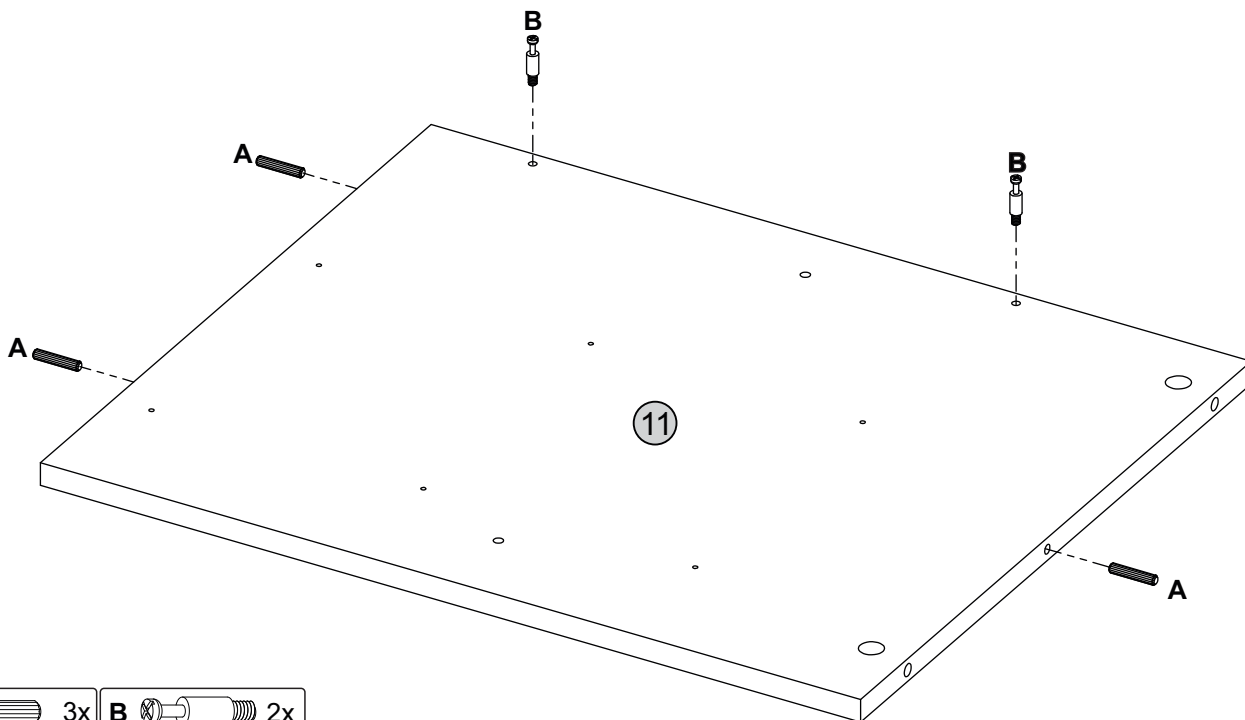

10

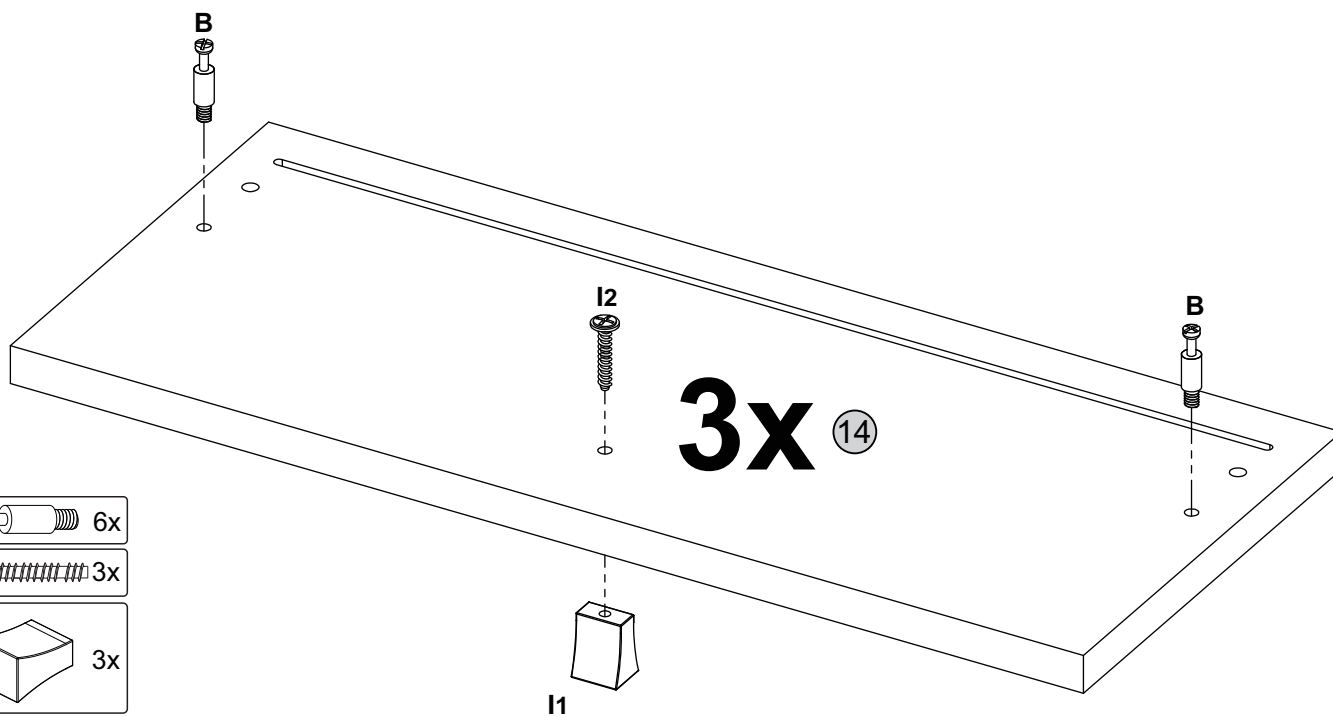

- A  3x
- B  2x

11

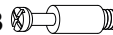
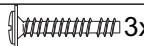

- B  6x
- I2  3x
- I1  3x

12

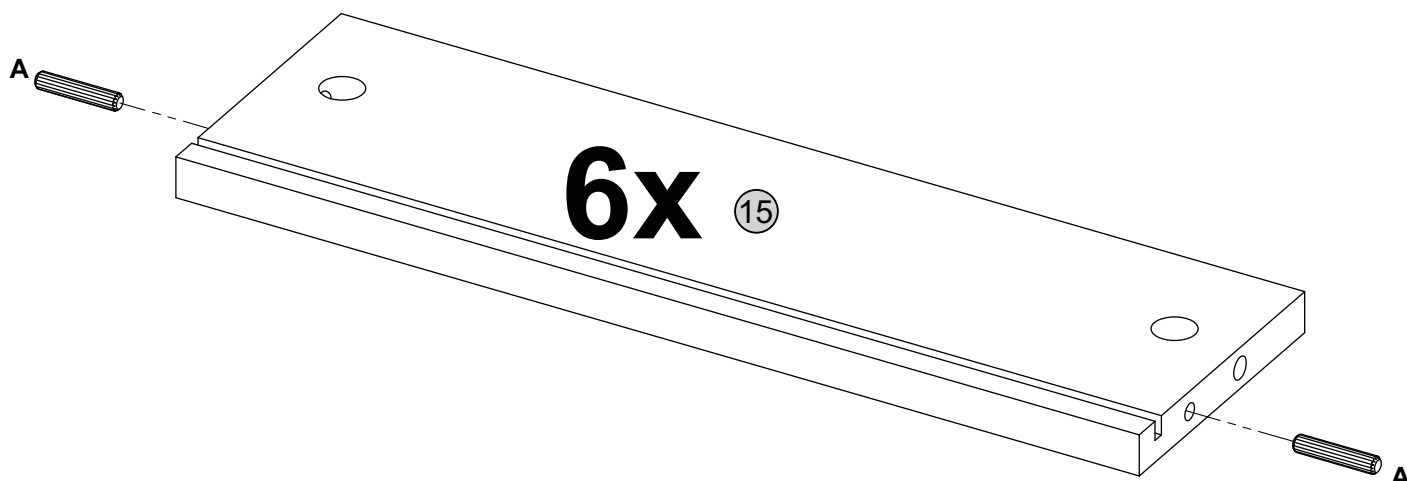

- A  12x

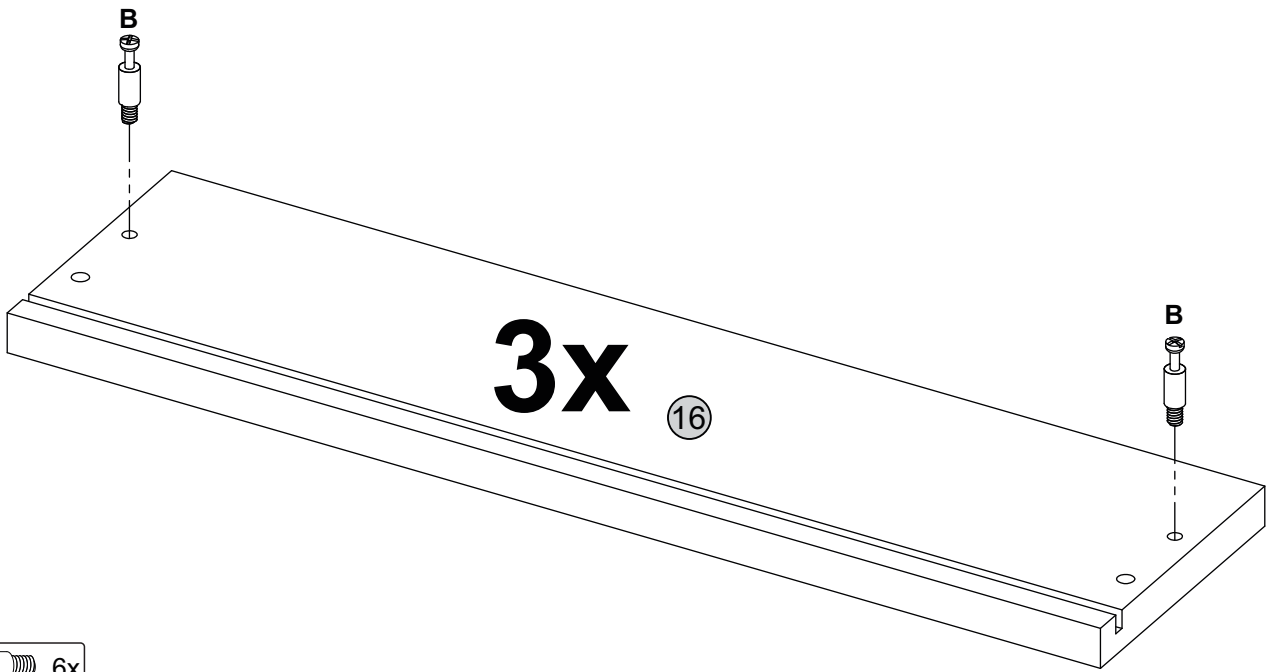

13

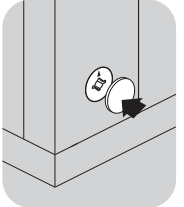
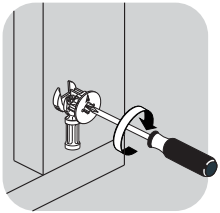
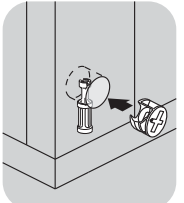
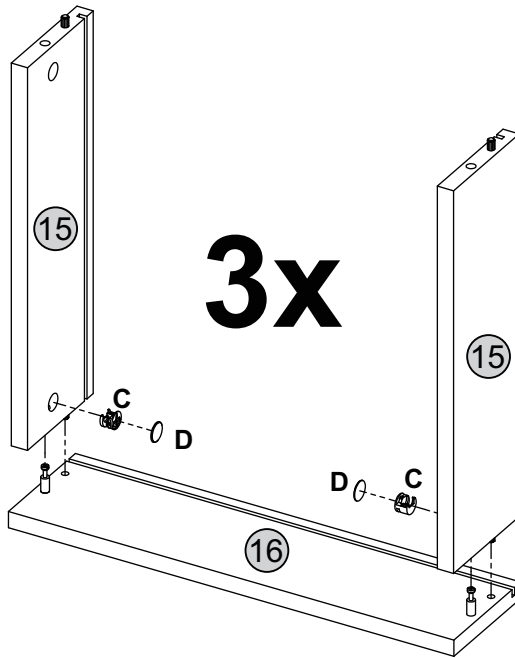

B  6x

14



C  6x D  6x

15

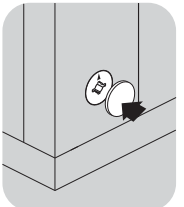
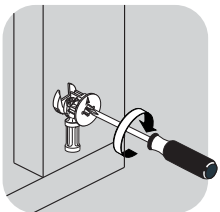
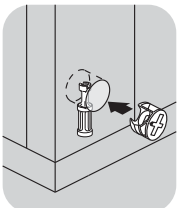
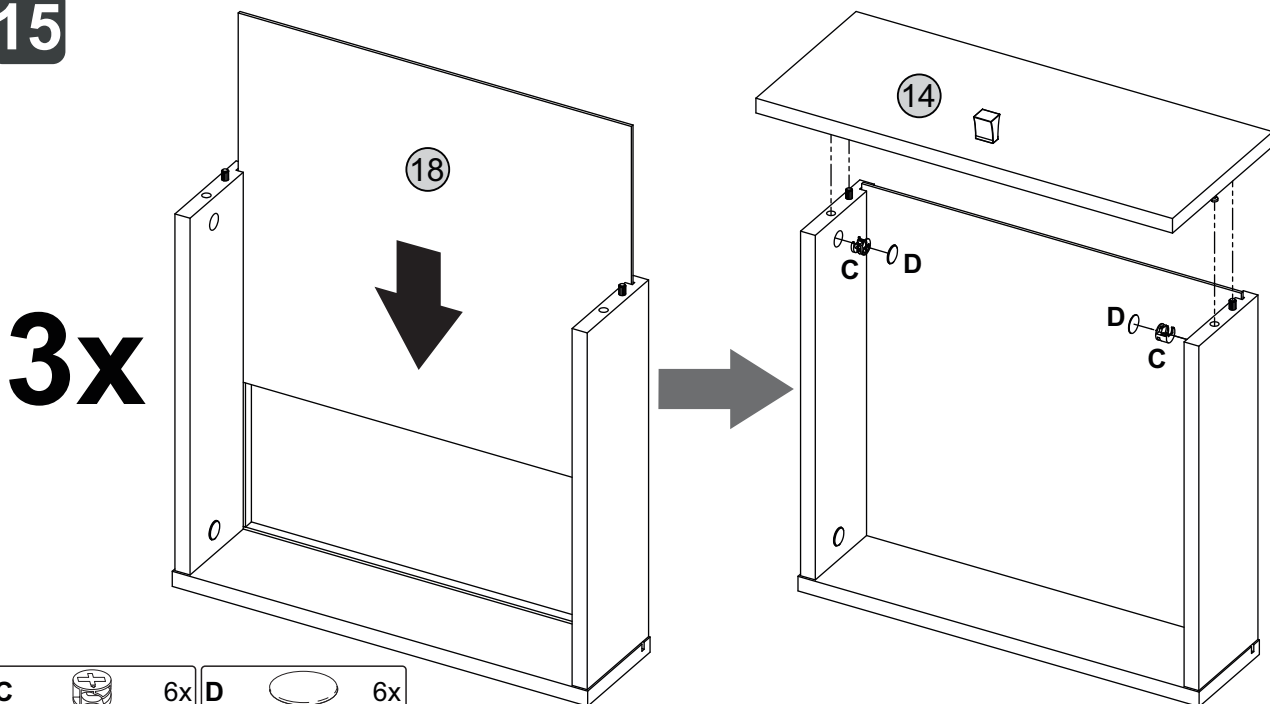

C  6x D  6x

16

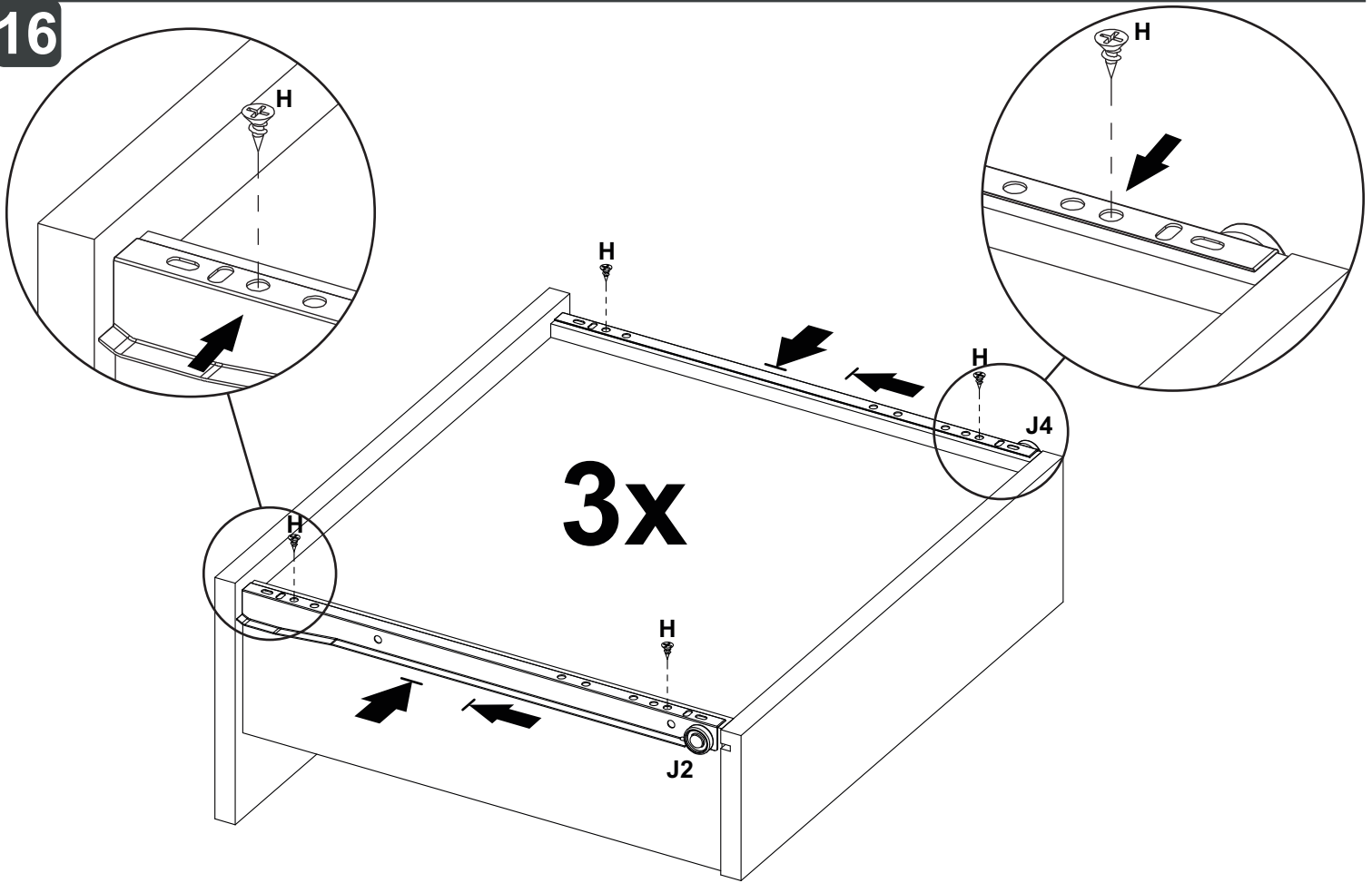

J2  3x
Esquerda / Izquierda / Left

J4  3x
Direita / Derecha / Right

H  12x
Ø3,5x12mm

~~G  Ø4,0x16mm~~

17

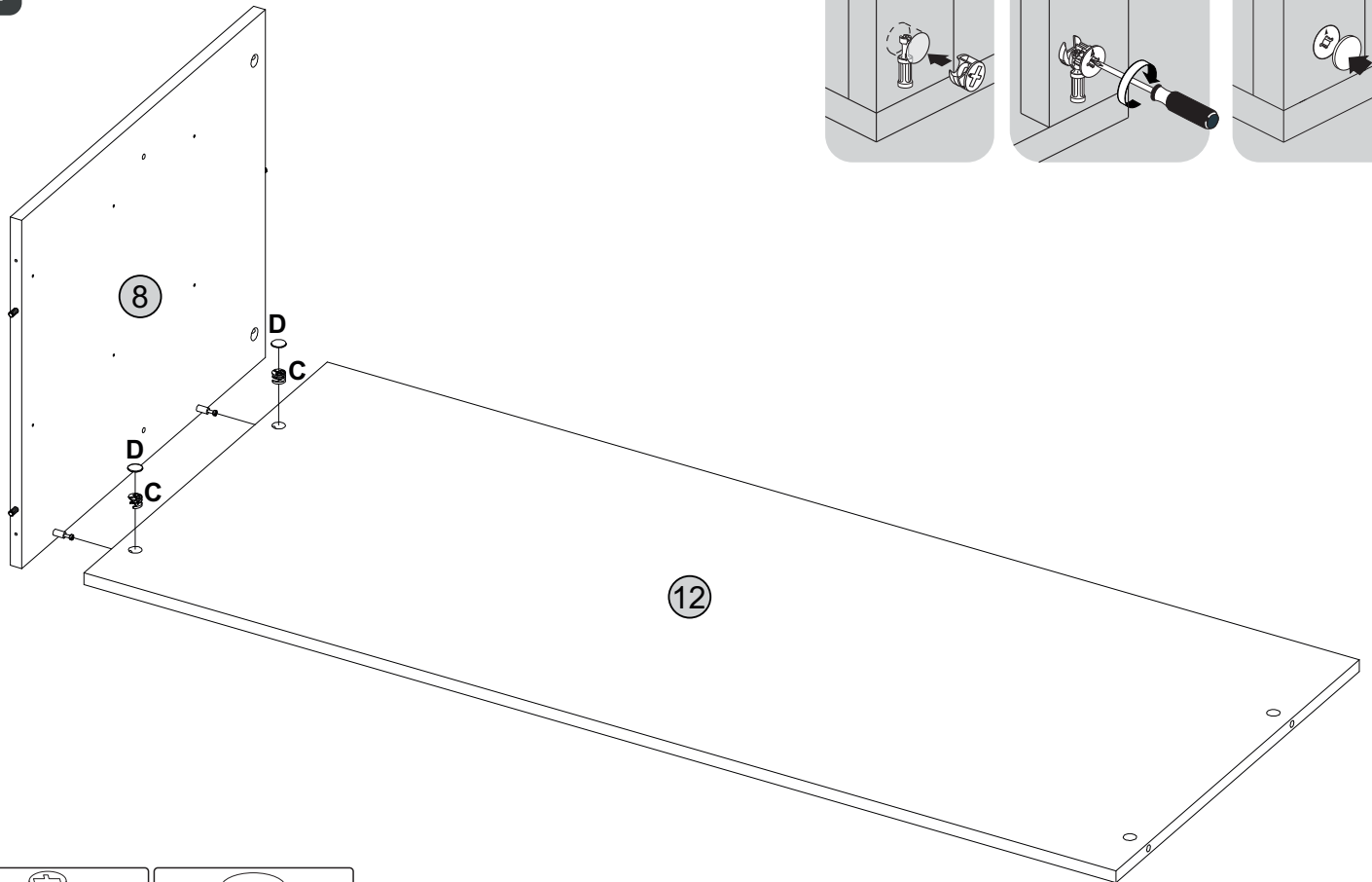

C  2x

D  2x

- 1A
- 2A
- 3A
- 4A

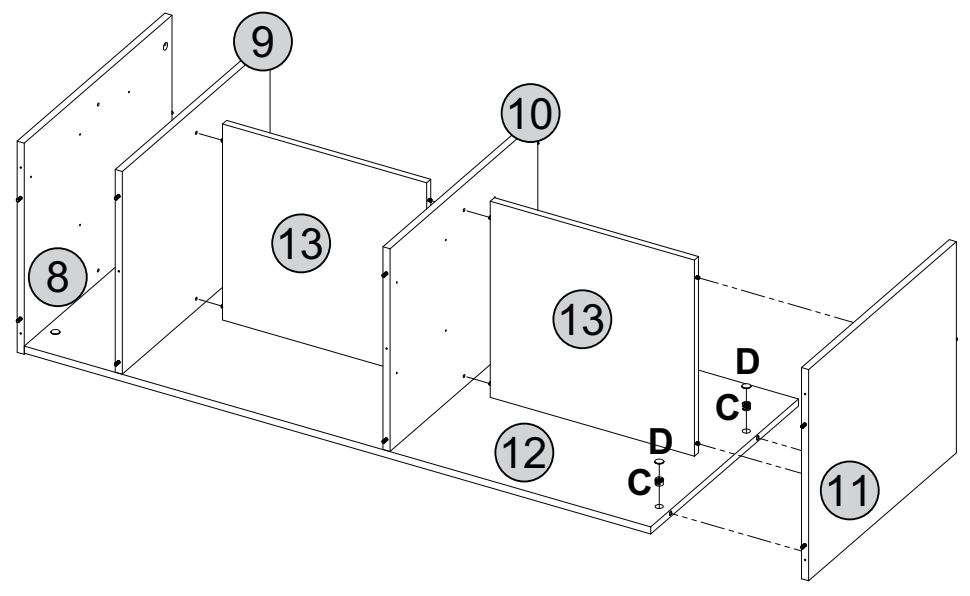
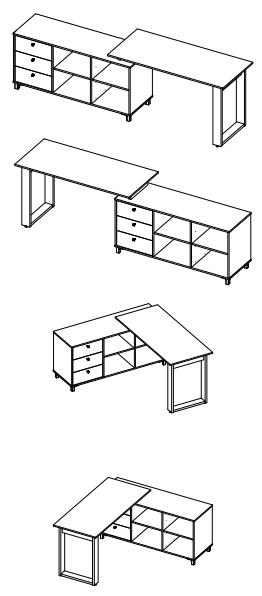

- 1B
- 2B
- 3B
- 4B

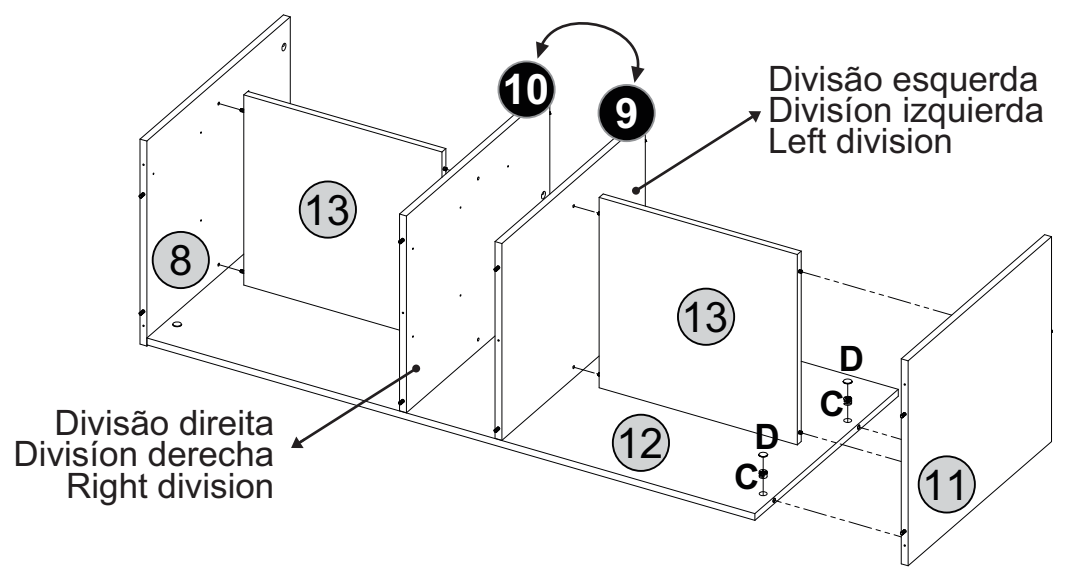
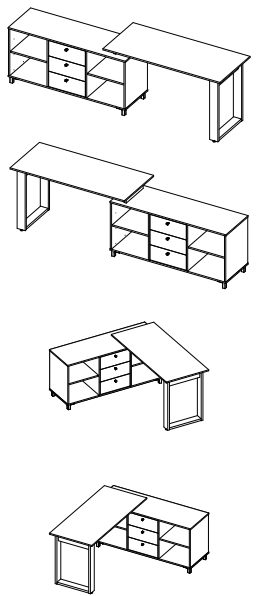

- 1C
- 2C
- 3C
- 4C

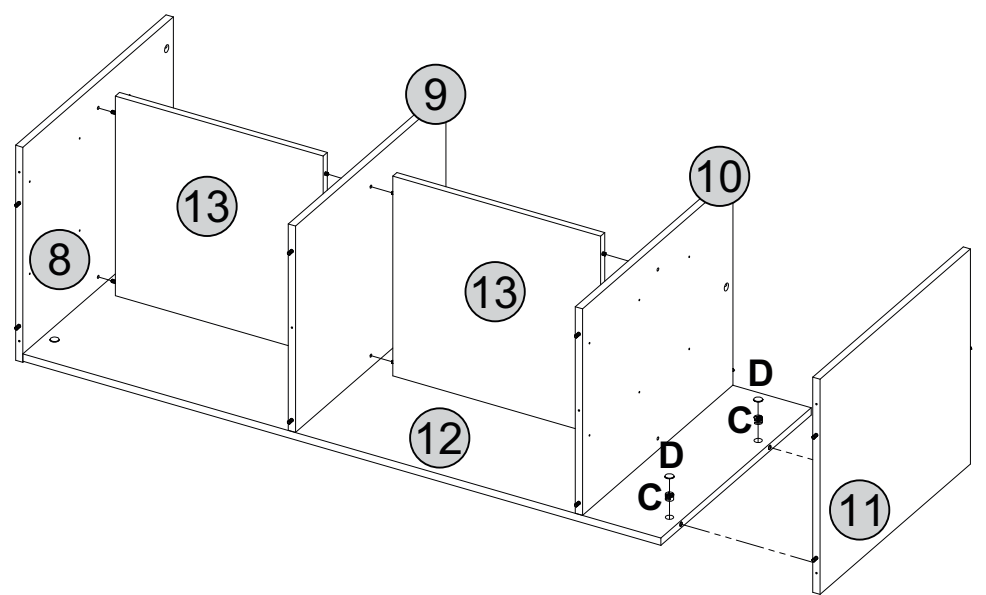
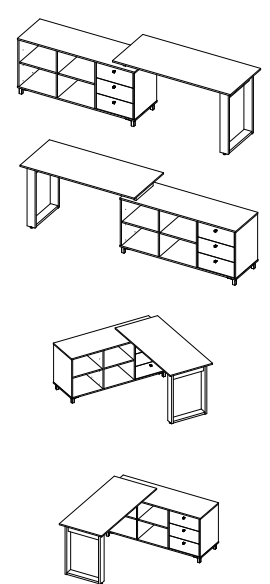

19

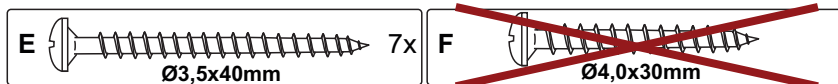
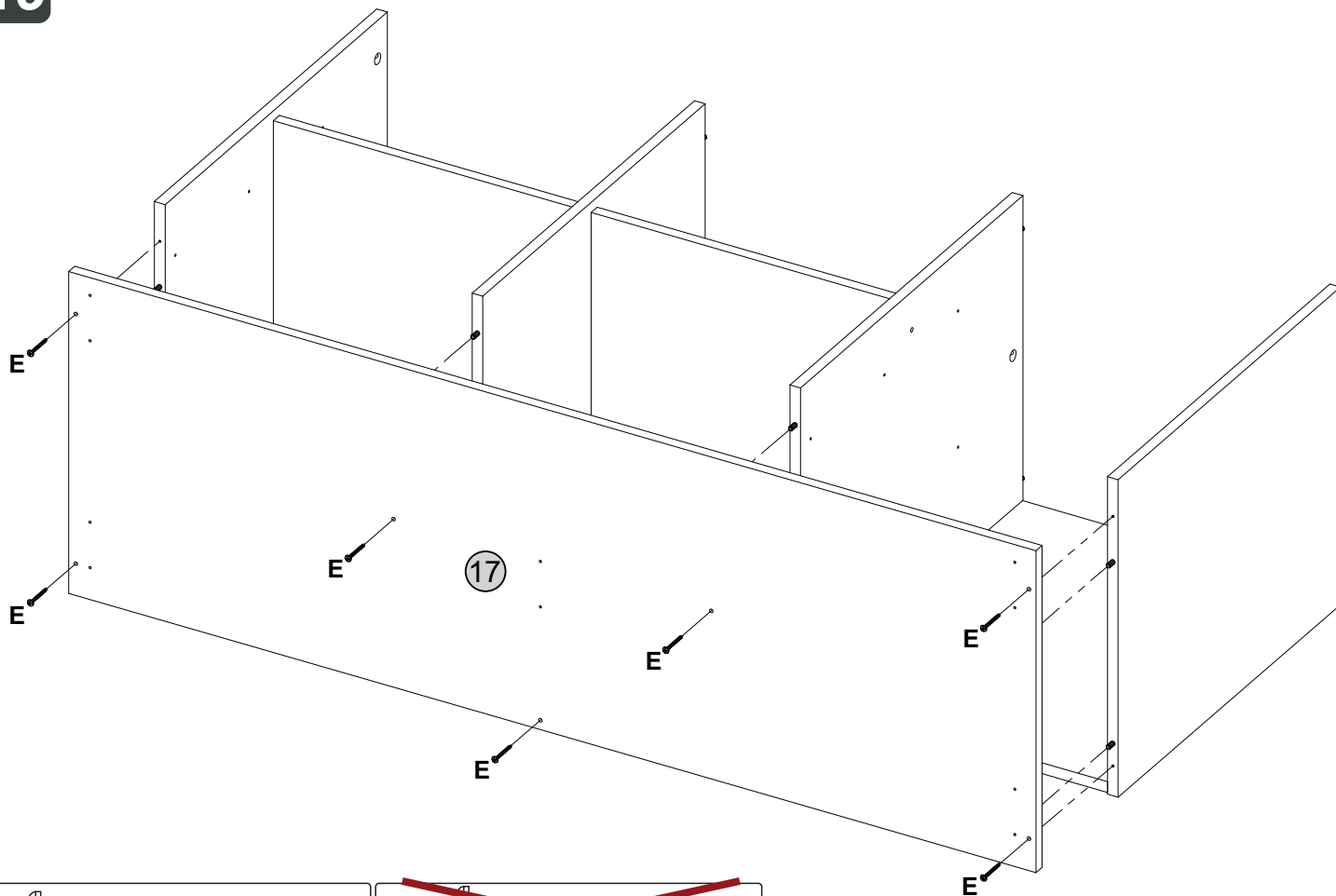

20

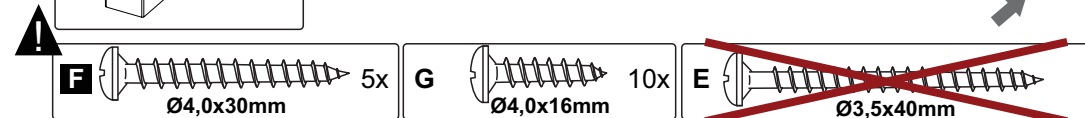
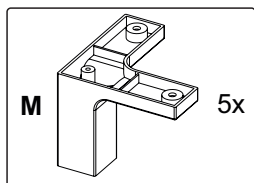
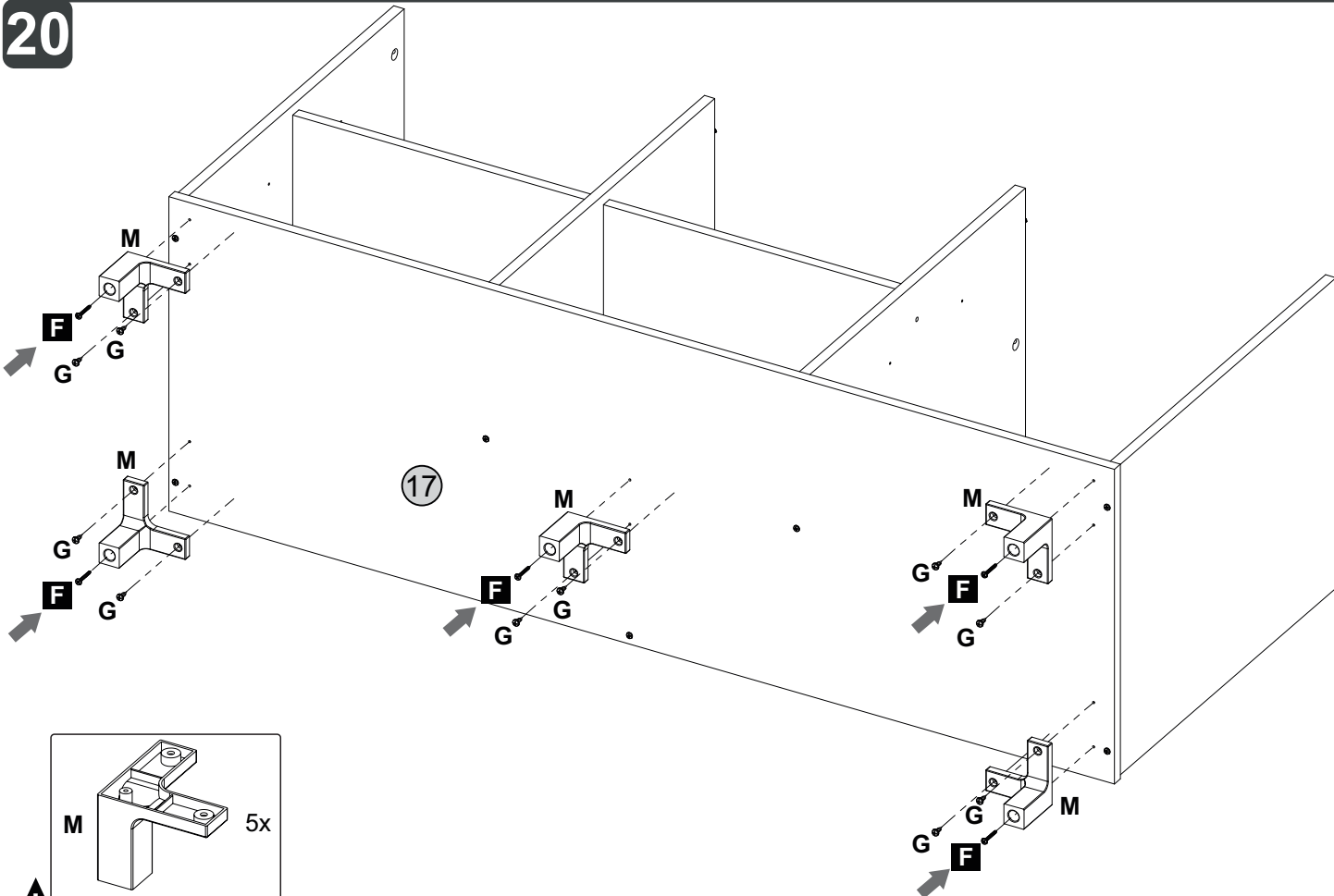

1A

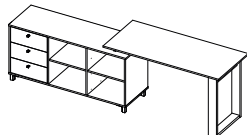

1B

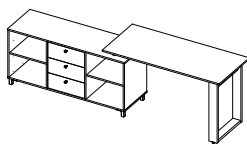

1C

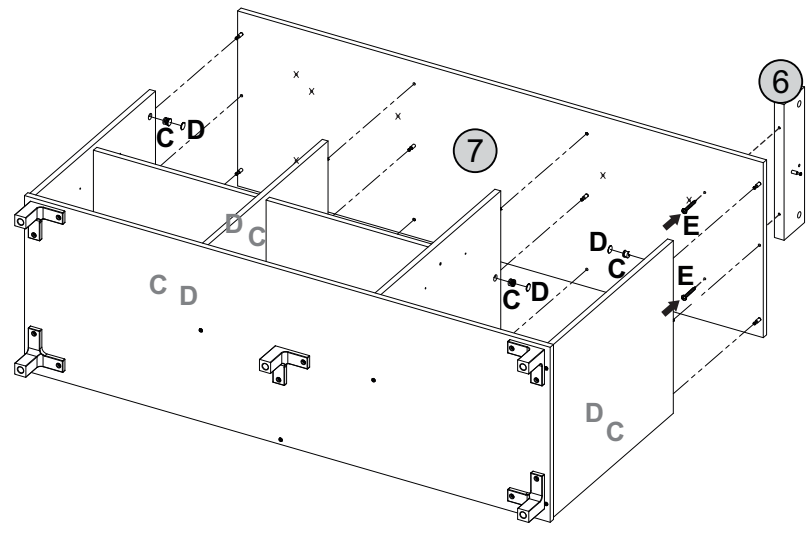
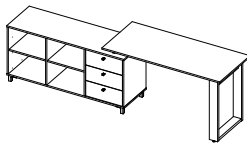

2A

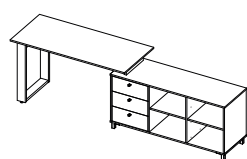

2B

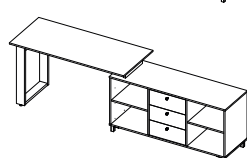

2C

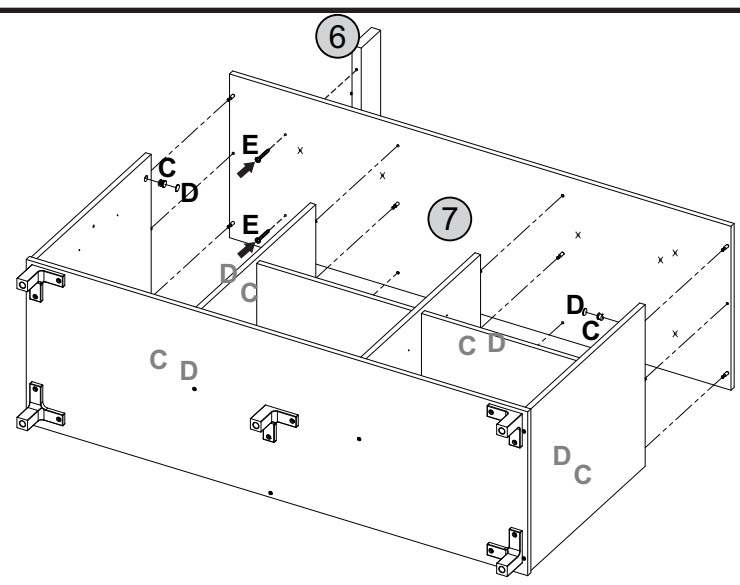
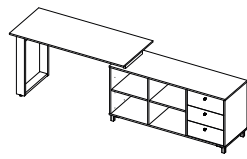

3A

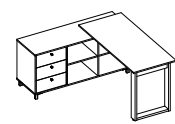

3B

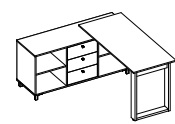

3C

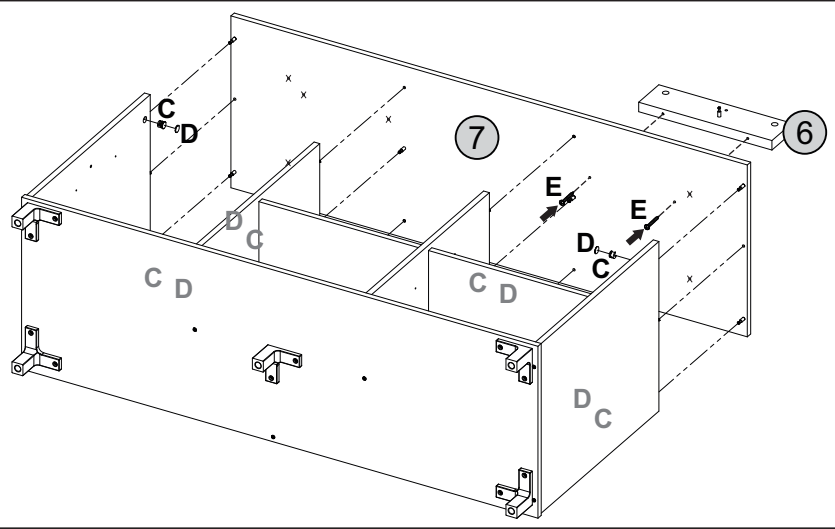
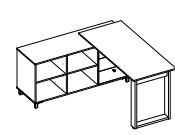

4A

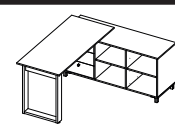

4B

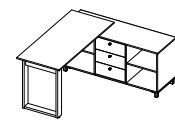

4C

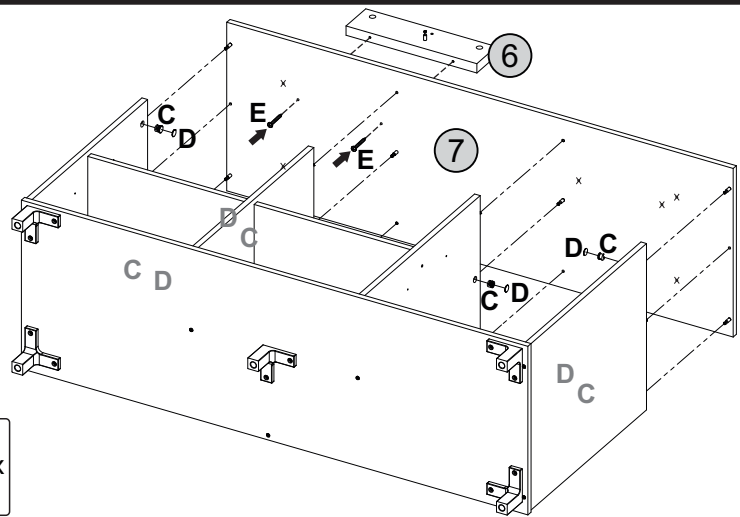
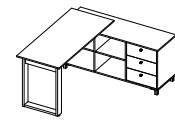

C		6x	2x Ø3,5x40mm
D		6x	

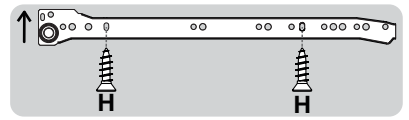

1A

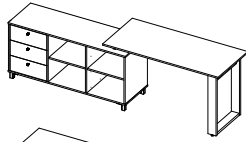

2A

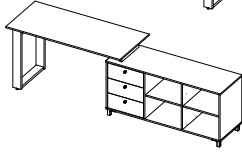

3A

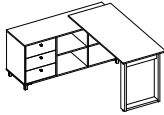

4A

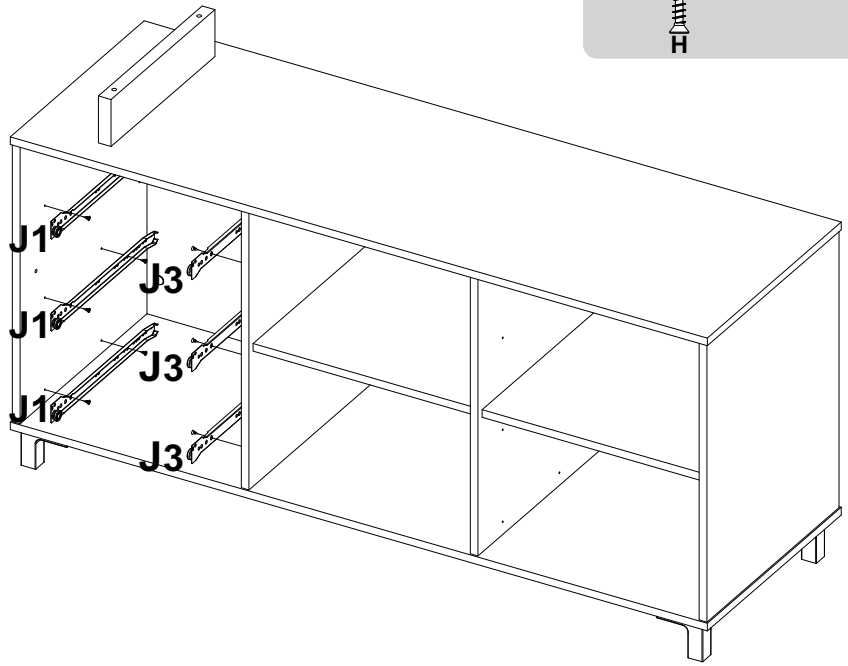
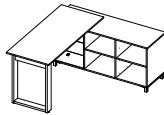

1B

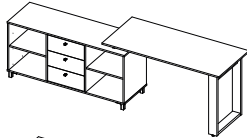

2B

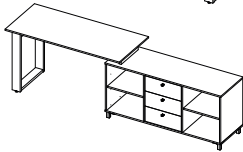

3B

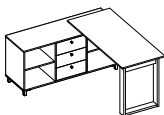

4B

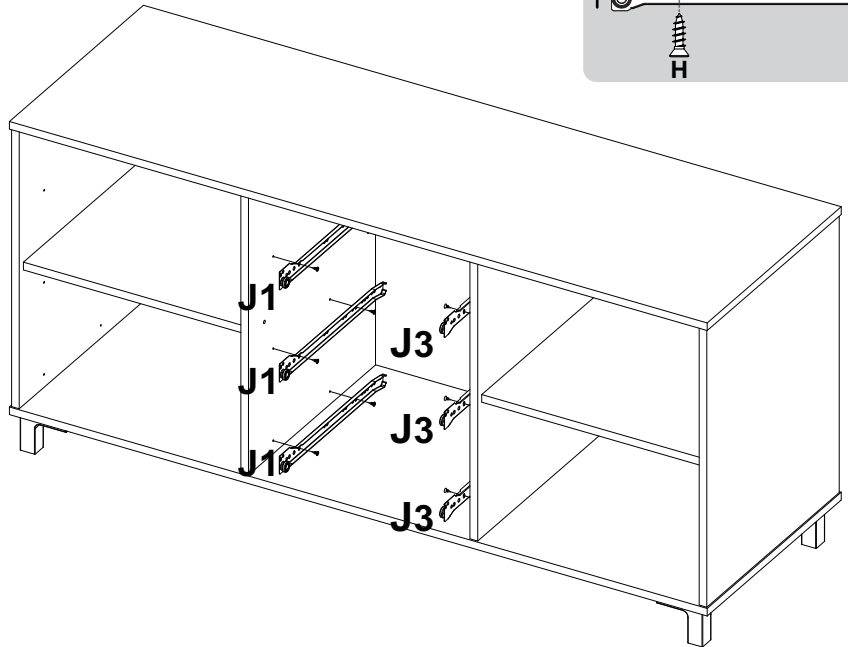
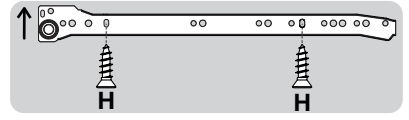
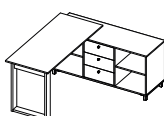

1C

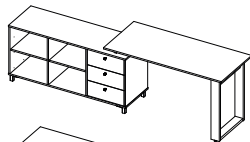

2C

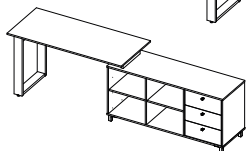

3C

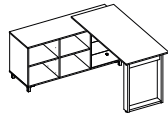

4C

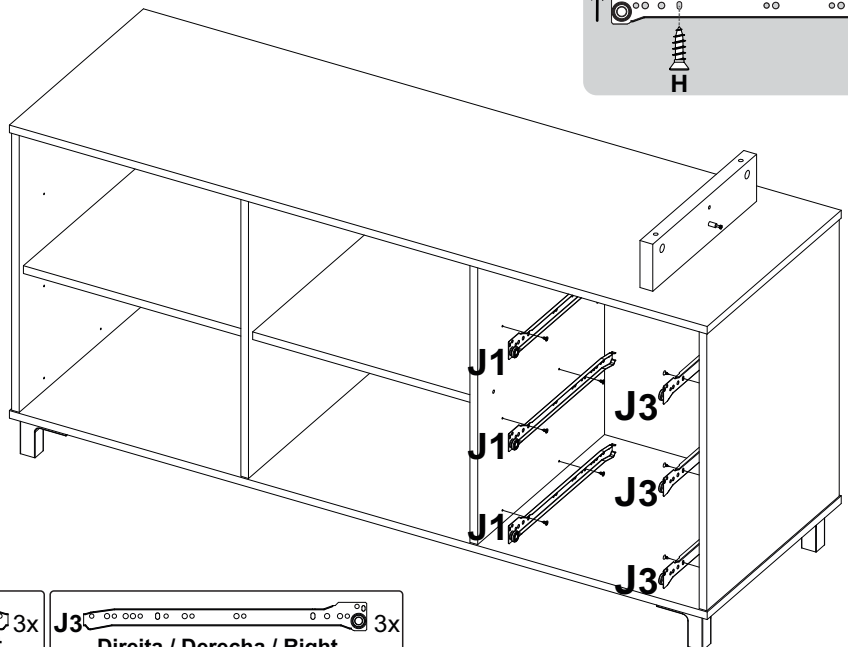
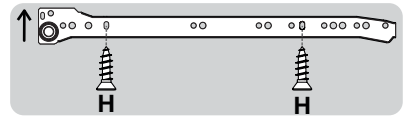
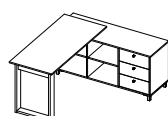

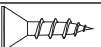
H  12x $\varnothing 3.5 \times 12 \text{mm}$

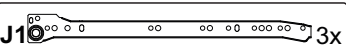
J1  3x
Esquerda / Izquierda / Left

J3  3x
Direita / Derecha / Right

23

ATENÇÃO

ATENCIÓN / ATTENTION

Ajustar a gaveta e colocar os parafusos

Ajustar el cajón y poner los tornillos
Adjust the drawer and put the screws

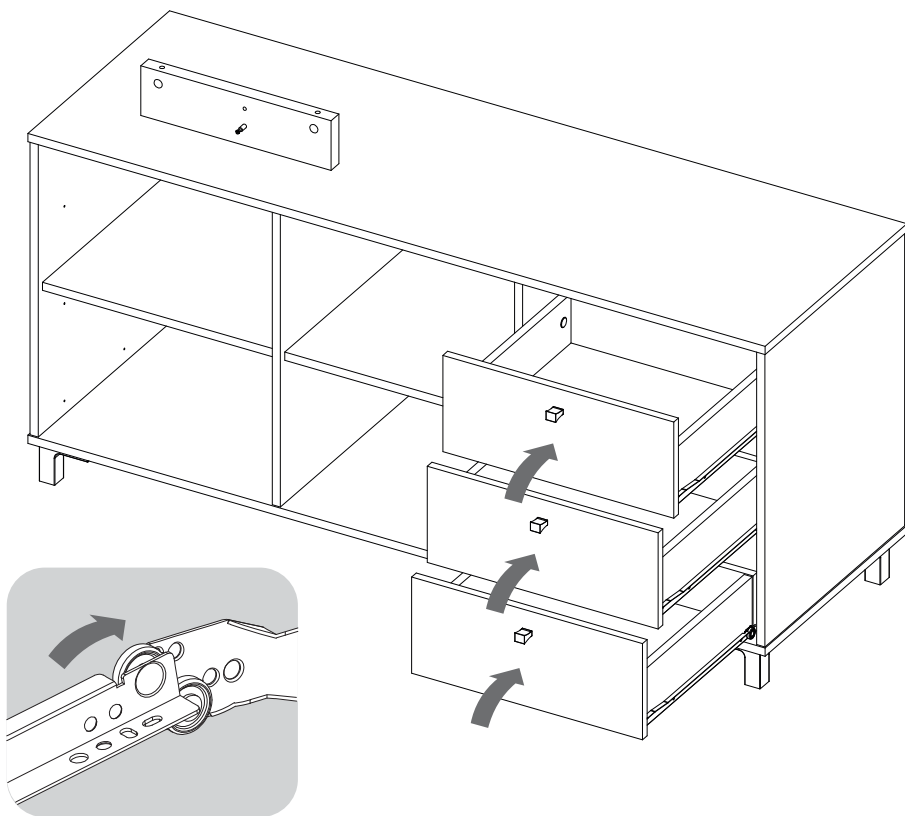
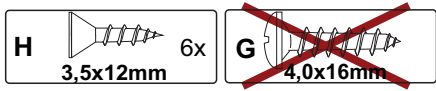
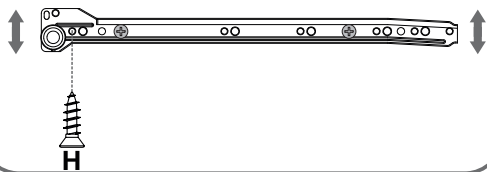

24

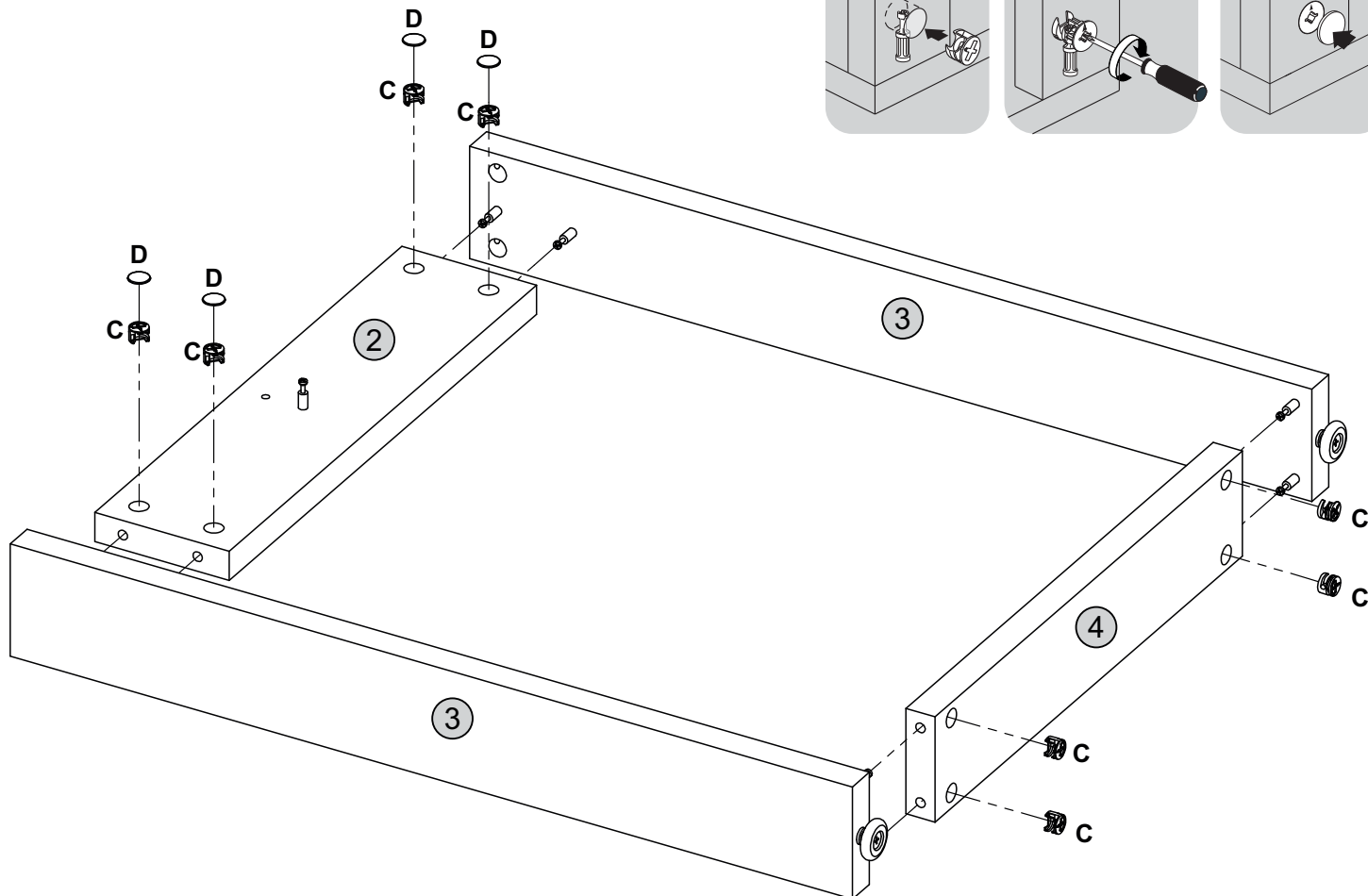

Manuseie com cuidado.
Manéjese con cuidado.
Handle with care.

- 1A
- 1B
- 1C

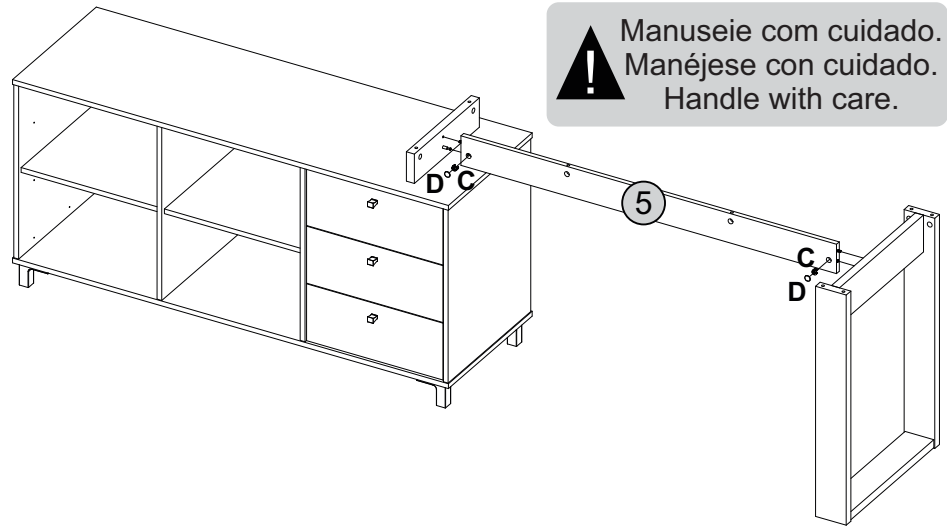
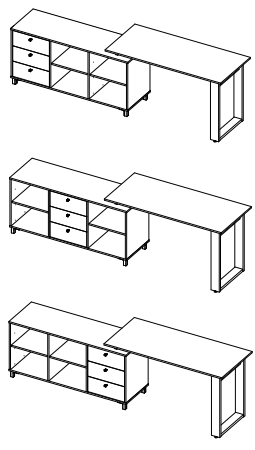

- 2A
- 2B
- 2C

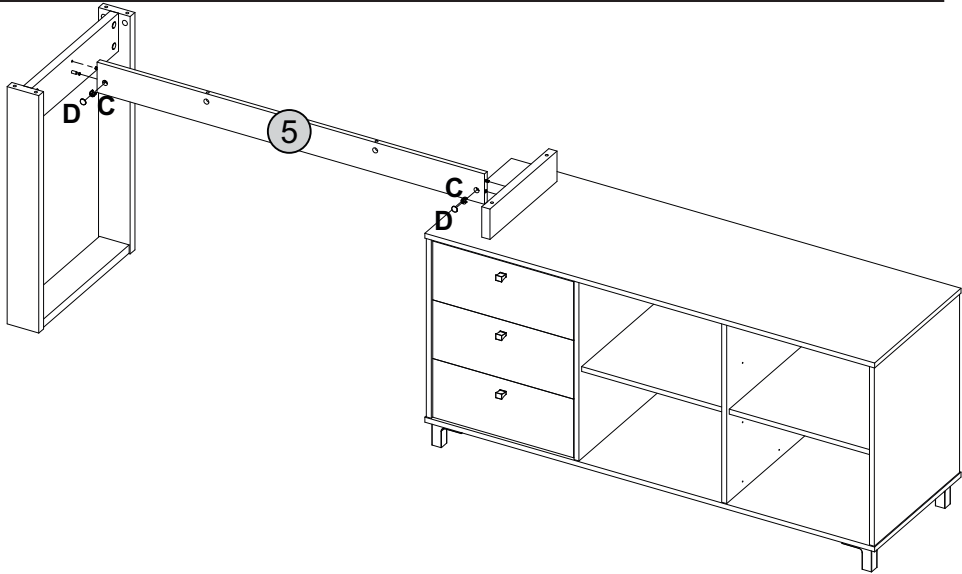
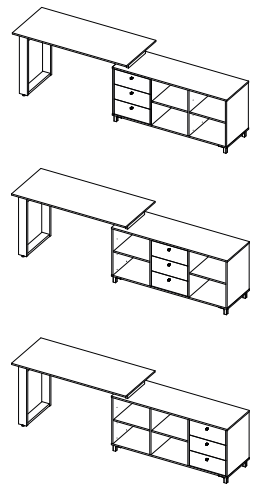

- 3A
- 3B
- 3C

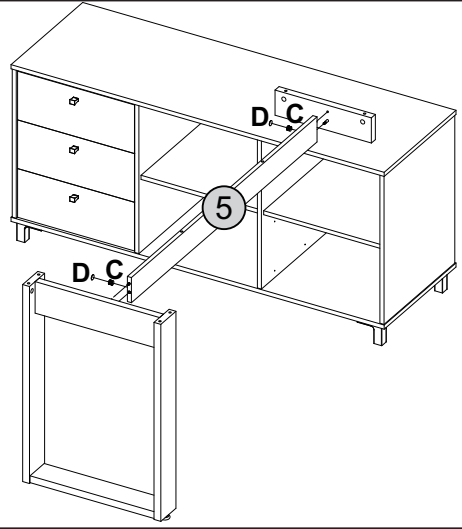
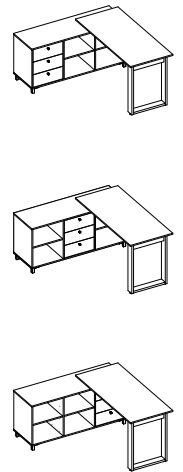

- 4A
- 4B
- 4C

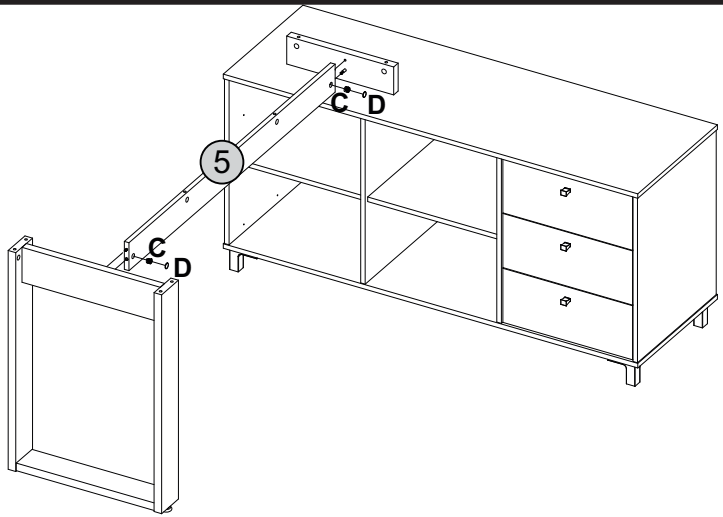
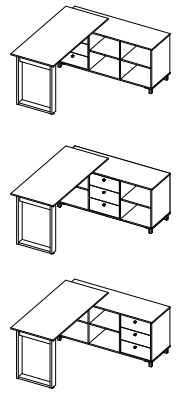

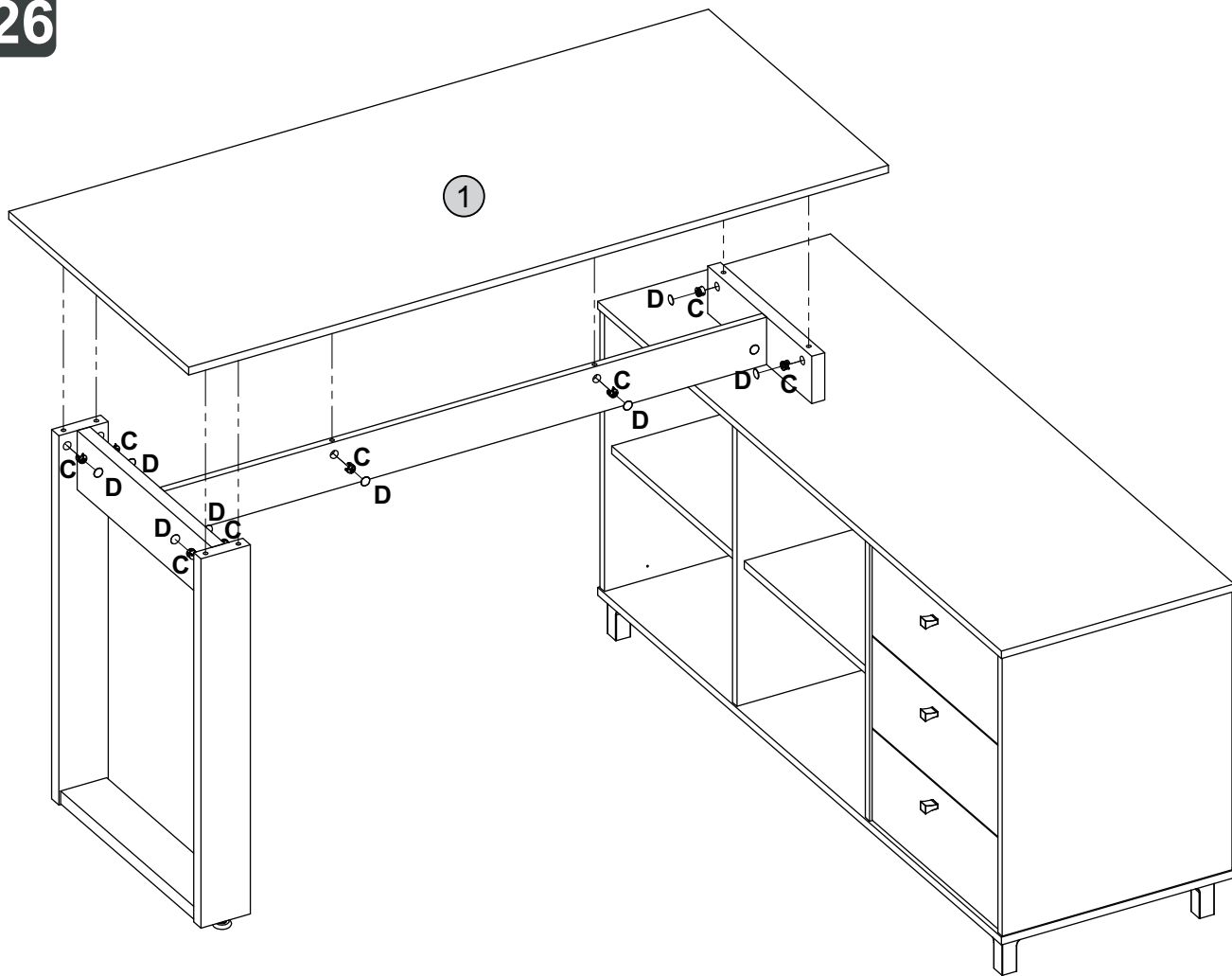

- C  8x
- D  8x

