

**HENN**Ind. e Com. de Móveis Henn  
Mondai - SC - Brasil

☎ +55 49 3674.3500

📷 @moveishenn  
www.henn.com.br**INSTRUÇÕES DE MONTAGEM**INSTRUCCIONES DE MONTAJE  
ASSEMBLY INSTRUCTIONS

Aéreo Nicho 200mm Connect | Niche Aérea 200mm Connect | Aerial Niche 200mm Connect

## Referência/Cor

c C82-23 Duna



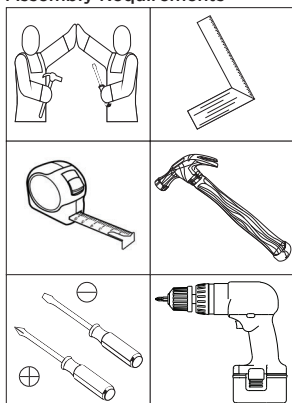
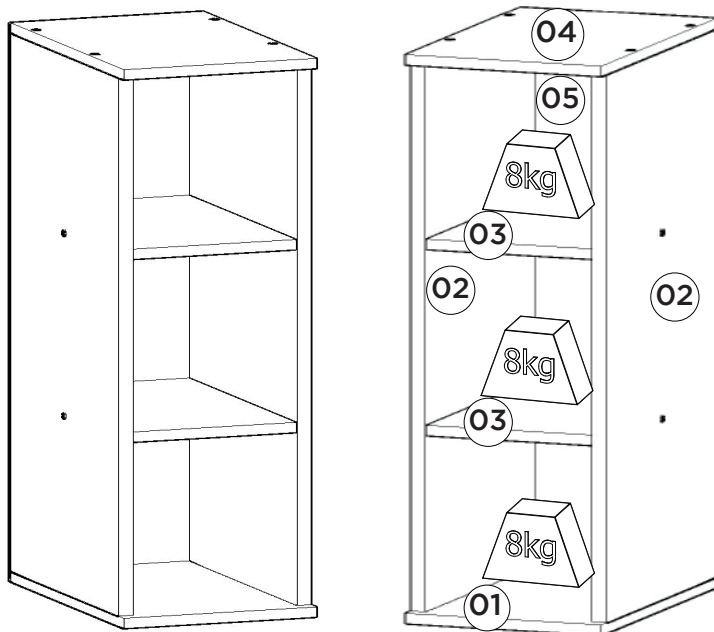



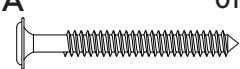

c C82-42 Fendi

Requisitos para montagem  
Requisitos para la montaje  
Assembly RequirementsImagens meramente ilustrativas  
Imágenes meramente ilustrativas  
Images for illustration onlyPesos máximos recomendados com carga distribuída  
Peso máximo recomendado con la carga distribuida  
Recommended maximum weight with distributed load.

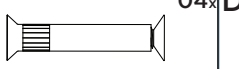
## Lista de Peças | Lista de piezas | List of parts

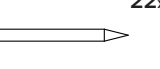
Item	Caixa Caja Box	Qtd Ctd Qty	Descrição   Descripción   Description	Medidas (mm)   Dimensions (mm)   Size (measurements) (mm)
01=04	1/1	01	Base tampo   Base cubierta   Base top	310x200x15
02	1/1	02	Lateral Direita Esquerda   Lateral Derecha Izquierda   Right Side Left	800x295x15
03	1/1	02	Prateleira   Estante   Shelf	293x169x15
04=01	1/1	01	Base tampo   Base cubierta   Base top	310x200x15
05	1/1	01	Fundo   Fondo   Bottom	824x193x3

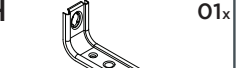
## Ferragens | Herrajes | Hardware

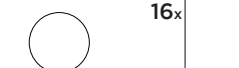
<b>A</b>  Parafuso 5,0x50mm FLA. Tornillo 5,0x50mm FLA. Screw 5,0x50mm FLA.	01x	<b>B</b>  Parafuso 3,5x40mm CHT. Tornillo 3,5x40mm CHT. Screw 3,5x40mm CHT.	12x	<b>C</b>  Parafuso União 30mm Tornillo Unión 30mm Union Screw 30mm	04x	<b>D</b>  Parafuso 3,5x14mm FLA. Tornillo 3,5x14mm FLA. Screw 3,5x14mm FLA.	02x	<b>E</b>  Cavilha 8x25mm Cinta 8x25mm Dowel 8x25mm	16x	<b>F</b>  Prego 10x10mm Clavo 10x10mm Nail 10x10mm	22x
<b>G</b>  Bucha plástica 8mm Bucha de plástico 8mm 8mm plastic bushing	01x	<b>H</b>  Suporte de fixação Soporte de fijación Mounting bracket	01x	<b>I</b>  Proteção para cantoneira Ángulo de protección Protection angle	01x	<b>J</b>  Sachê de cola Bolsa de pegamento Glue bag	01x	<b>K</b>  Adesivo tapa parafuso 10mm Adhesivo tapón de tornillo 10mm Bolt cover adhesive 10mm	16x		



O parafuso (C) deve ser usada somente quando este módulo for acoplado a outro módulo componível Henn.



El tornillo (C) se debe utilizar sólo cuando el módulo está conectado a otro módulo componible Henn.



The screw (C) should be used only when this module is attached to another Henn modular module.

**RECOMENDAÇÃO**

Para fixar o móvel na parede usar o suporte de fixação (H), o parafuso 3,5x14mm FLA (D), a Bucha 8mm (G) e o parafuso 5,0x50mm FLA (A).

**RECOMENDACIÓN**

Para conectar el móvil a la pared con el soporte (H), tornillo 3,5 x14mm FLA (D), el casquillo de 8 mm (G) y el 5,0 x50mm tornillo FLA (A).

**RECOMMENDATION**

To fix the furniture to the wall use the fixing bracket (H), the 3.5x14mm FLA (D) screw, the 8mm bushing (G) and the 5.0x50mm FLA screw (A).

1°

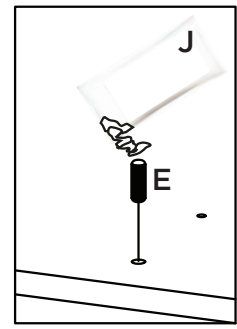
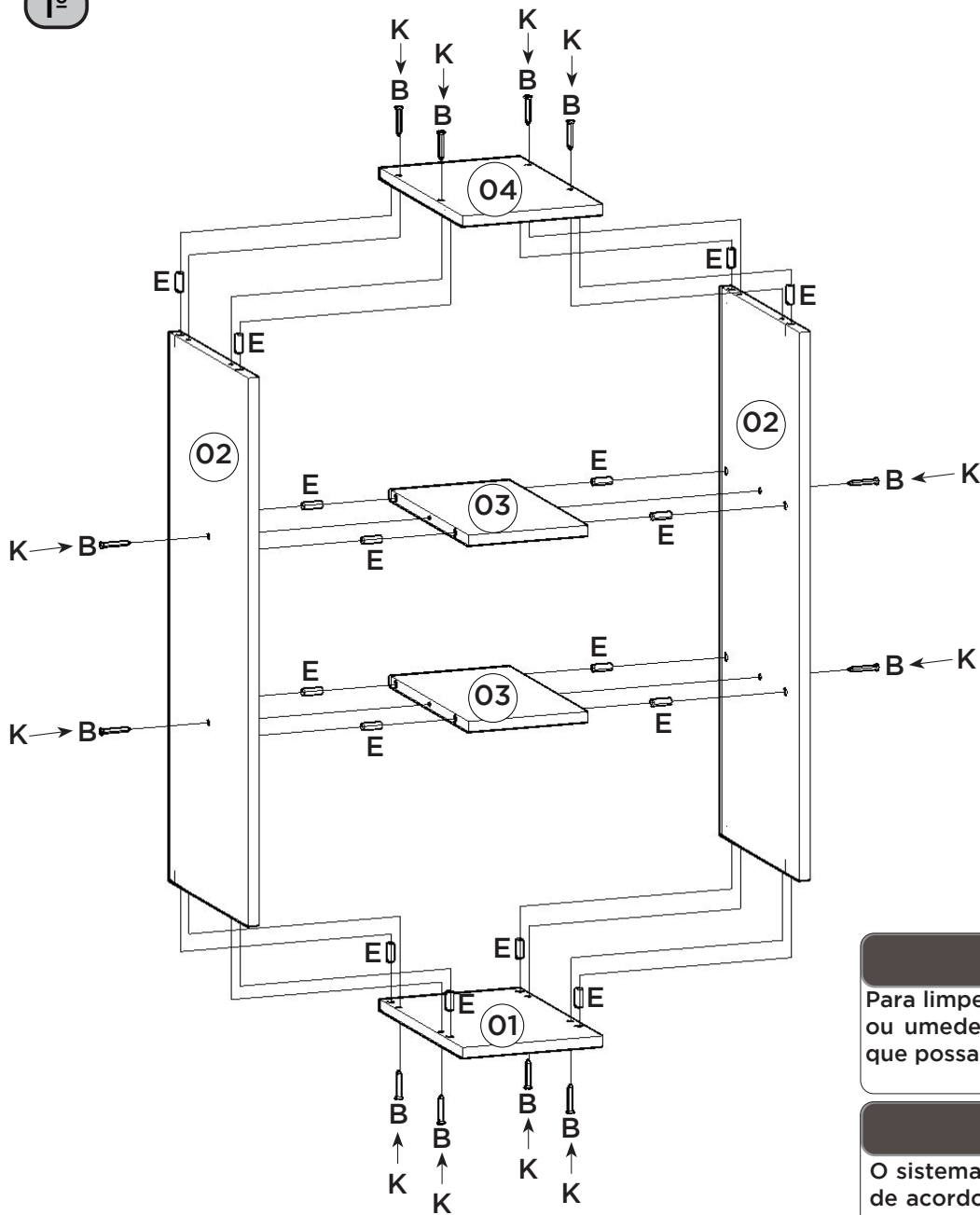

Utilizar o sachê de cola (J) em todas as cavilhas (E) do produto.

Con el pegamento sobre (J) en todos los pernos (E) producto.

Use the glue sachet (J) on all the pegs (E) of the product.

#### AVISO

Para limpeza de seu móvel, use uma flanela seca ou umedecida, e não utilize produtos químicos que possam danificar seu produto.

#### SISTEMA DE MONTAGEM

O sistema de montagem dos produtos, funciona de acordo com a ordem crescente dos números indicados no desenho. Ex: 01, 02, 03, 04... até a conclusão da montagem.

#### ADVERTENCIA

Para limpieza de su móvil, use una flanela seca o húmeda, y no utilice productos químicos que puedan dañar su producto.

#### SISTEMA DE MONTAJE

El sistema de montaje de los productos funciona de acuerdo con el orden creciente de los números indicados en el dibujo. Ej.: 01, 02, 03, 04... hasta la conclusión del montaje.

#### NOTICE

To clean your furniture, use a dry or wet cloth, and do not use chemicals that may damage your product.

#### ASSEMBLY SYSTEM

The products' assembly system works according to the increasing order of the indicated numbers. For example: 01, 02, 03, 04 ... to the end of the assembly.

2°

