

CÓDIGO DE PEÇAS | CODE OF PIECES | CÓDIGO DE PIEZAS

Vista frontal
Front view
Vista frontal

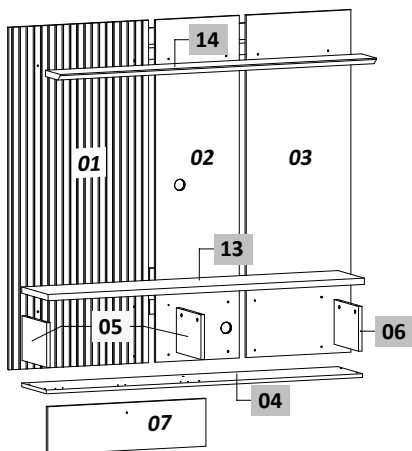

Vista traseira
Back view
Vista trasera

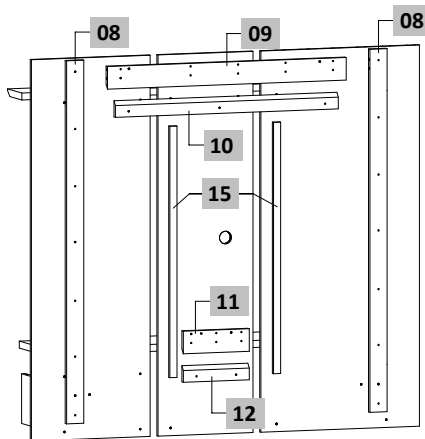

Edição: | Edition: | Edición: 29/11/2024



INSTRUÇÕES | INSTRUCTIONS | INSTRUCCIONES

- Prepare a montagem do móvel próximo ao local que ele ficará definitivamente e evite deslocá-lo depois de montado;
- Forre o chão com papelão ou similar e utilize a isomanta que vem entre as peças para evitar o contato entre elas durante a montagem;
- Monte o móvel obedecendo a ordem numérica da **seqüência de montagem (S.M.)**, identificando as peças pelo **código de peça (C.P.)** carimbado na mesma, de acordo com a tabela.

- Prepare the assembly of the close piece of furniture to the place that it will be definitively and avoid to move after done. Will be definitively and avoid to move after done;
- Cover the ground with cardboard or similar and use the isomanta that it comes among the pieces to avoid the contact among them during the assembly;
- Set up the piece of furniture obeying the numeric order of the **assembly sequence (S.M.)**, identifying the pieces by **code of piece (C.P.)** stamped in the same, in agreement with the table.

- Prepare la montaje del mobiliario proximo al lugar que estará definitivamente y evite mover después de hecho;
- Tape la suelo con cartón o similar y use la "isomanta" que viene entre las piezas para evitar el contacto entre ellos durante la montaje;
- Monte el mobiliario obedeciendo el orden numérico de la **sucesión de montaje (S.M.)**, identificando las piezas por el **código de piezas (C.P.)** de la misma estampado en esta, de acuerdo con la tabla.

*Dimensões em milímetros | Dimensions in millimeters | Dimensiones en milímetros

Pessoas necessárias para montagem People needed for assembly Personas necesarias para el montaje	Ferramentas necessárias para montagem (não fornecidas) Tools required for assembly (not supplied) Herramientas necesarias para el montaje (no suministradas)	Tempo Montagem Assembly time Tiempo montaje
 2 pessoas / 2 people / 2 personas	 Parafusadeira / Screwdriver / Destornillador	 Martelo / Hammer / Martillo
	 Chave de Fenda e Phillips	 120 min



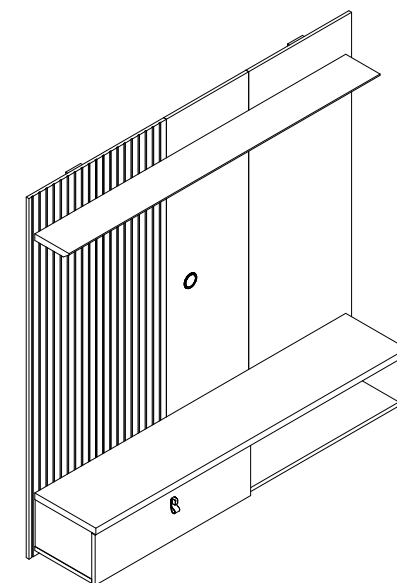



REF.:	CÓDIGO DA PEÇA CODE PIECE CÓDIGO DE PIEZA			DESCRIÇÃO DA PEÇA PART DESCRIPTION DESCRIPCIÓN DE PIEZA	MATÉRIA PRIMA FEEDSTOCK	DIMENSÕES* DIMENSIONS DIMENSIONES	QUANT. AMOUNT CANTIDAD
	CUMARU	CINAMOMO OFF WHITE	CUMARU OPALA				
01	204136.039	204136.026	204136.039	Painel lat. esq. frisado Beaded left side panel Panel lat izq con cuentas	MDF	1,365 x 0,601 x 0,012	1
02	204137.039	204137.026	204137.039	Painel central Center panel Panel central	MDF	1,365 x 0,360 x 0,012	1
03	204138.039	204138.026	204138.039	Painel lateral direito Latted overlapping panel Panel superpuesto ripado	MDF	1,365 x 0,450 x 0,012	1
04	204139.039	204139.026	204139.040	Base Base Base	MDF	1,360 x 0,257 x 0,015	1
05	204140.039	204140.026	204140.040	Lateral esquerda / divisão Right left side/Division Lado derecho izquierdo/División	MDP	0,257 x 0,178 x 0,015	1
06	204141.039	204141.026	204141.040	Lateral direita Right left side Lado derecho izquierdo	MDP	0,255 x 0,178 x 0,015	1
07	204142.039	204142.026	204142.040	Porta basculante Tilting door Puerta basculante	MDP	0,680 x 0,190 x 0,015	1
08	204143.009	204143.009	204143.009	Travessa lateral Lower side crossbar Travessa lateral inferior	MDP	1,290 x 0,065 x 0,015	2
09	204144.009	204144.009	204144.009	Apoio superior do painel Upper panel support Soporte superior del panel	MDP	0,905 x 0,081 x 0,015	1
10	204145.009	204145.009	204145.009	Apoio superior da parede Upper wall support Soporte superior de la pared	MDP	0,840 x 0,058 x 0,015	1
11	204146.009	204146.009	204146.009	Apoio inferior do painel Lower panel support Soporte inferior del panel	MDP	0,298 x 0,081 x 0,015	1
12	204147.009	204147.009	204147.009	Apoio inferior da parede Lower wall support Soporte inferior de la pared	MDP	0,298 x 0,058 x 0,015	1
13	204148.039	204148.009	204148.009	Tampo Top Tampo	MDP	1,360 x 0,275 x 0,025	1
14	204149.039	204149.037	204149.039	Prateleira superior Upper shelf Estante superior	MDP	1,360 x 0,149 x 0,025	1
15	204150.009	204150.009	204150.009	Gabarito para fixar cunha Template to fix wedge Plantilla para fijar cuña	MDF	0,900 x 0,027 x 0,012	2



ACESSÓRIOS | ACCESSORIES | ACCESORIOS

PARAFUSOS | Screw | Tornillo







CÓDIGO | CODE

A		Parafuso Screw Tornillo 5,0x70	5x	102100018
B		Parafuso Screw Tornillo 5,0x50 (Estrutural)	18x	102100045
C		Parafuso Screw Tornillo 3,5x40	6x	102100012
D		Parafuso Screw Tornillo 3,5x25	31x	102100004
E		Parafuso Screw Tornillo 3,5x14	12x	102100003
F		Parafuso Screw Tornillo 3,5x10	20x	102100035

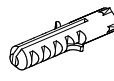
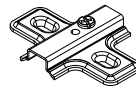

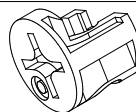
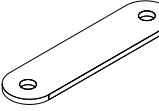
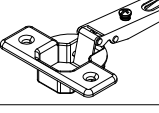
RELAÇÃO DE COR DOS ACESSÓRIOS COLOR RATIO OF ACCESSORIES RELACIÓN DE COLOR DE ACCESORIOS

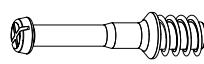
LETRA LETTER	DESCRIÇÃO DESCRIPTION DESCRIPCIÓN	MATÉRIA PRIMA FEEDSTOCK	COR COLOUR COLOR	QUANT. AMOUNT CANTIDAD			CÓDIGO CODE
				CUMARU	CALACATA OFF WHITE	CINAMOMO OFF WHITE	
R	 Giz p/ correção Touch-up chalk Tiza correctora	Cera Wax	Off White Calacata		1	1	102140009
			Cinamomo			1	102140023
			Cumaru	1			102140026
S	 Tapa furo adesivo 18mm Adhesive hole cover 18mm Tapa agujero adhesivo 18mm	Plástico Plastic	Off White		6	6	102080216
			Cumaru	6			102080288

LETRA LETTER	DESCRIÇÃO DESCRIPTION DESCRIPCIÓN	MATÉRIA PRIMA FEEDSTOCK	QUANT. AMOUNT CANTIDAD	CÓDIGO CODE
G	 Bucha para parede 8mm Bucha for wall 8mm Buja para pared 8mm	Plástico Plastic	5	102060079
H	 Calço baixo 48x35x12mm Low shim 48x35x12mm Calzón bajo 48x35x12mm	Metal	3	102010042
I	 Cavilha 6x30mm Dowel 6x30mm Clavija 6x30mm	Madeira Wood Madera	10	102050001
J	 Castanha girofix 12x10mm Girofix chestnut 12x10mm Castaña girofix 12x10mm	Metal	6	102050006
K	 Chapa fixadora 50x13 Fixing plate 50x13 Placa fijadora 50x13	Metal	10	102050018
L	 Dobradiça 80x43x18mm Hinge 80x43x18mm Bisagra 80x43x18mm	Metal	3	102010029
M	 Etiqueta resinada Resin label Etiqueta de resina	Plástico Plastic	1	102080013
N	 Guia cabo 45x17mm Cable guide 45x17mm Guía de cable 45x17mm	Plástico Plastic	2	102060070
O	 Pino girofix 5,0x30mm Girofix pin 5,0x30mm Pino girofix 5,0x30mm	Metal	6	102050007
P	 Puxador Toro Toro puller Tirador Toro	Plástico Plastic	1	102020051
Q	 Sache de cola 12g Sachet of glue 0,42oz Bolsita de pegamento 0,42oz	Cola Glue	2	102050020

1º PASSO | PASS | PASO

PEÇAS
PIECES
PIEZAS

S.M.	C.P.
01	04
02	05
03	05
04	06
05	13

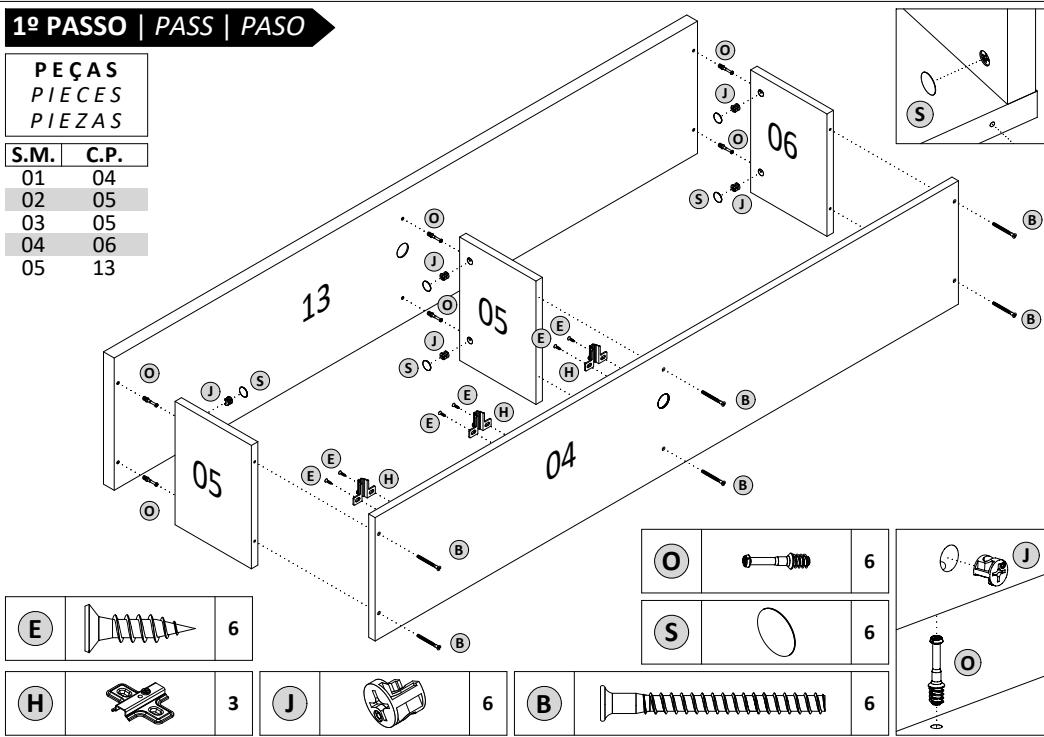

E		6	O		6	J		6
H		3	S		6	B		6

3º PASSO | PASS | PASO

PEÇAS
PIECES
PIEZAS

S.M.	C.P.
01	02

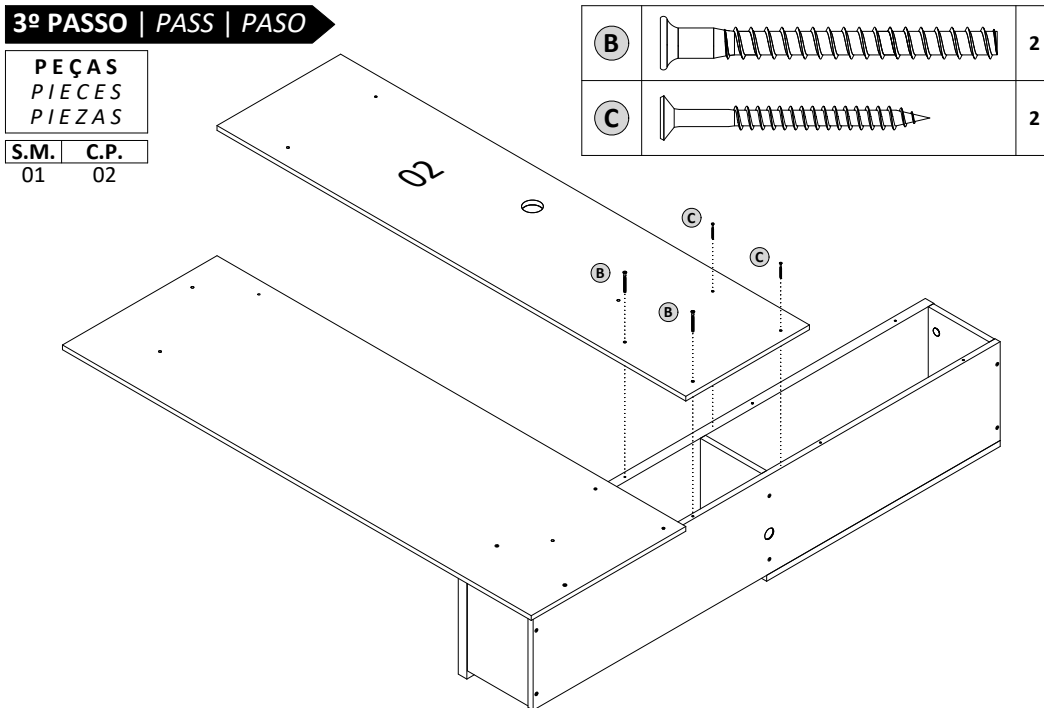

B		2
C		2

2º PASSO | PASS | PASO

B		2
C		2

PEÇAS
PIECES
PIEZAS

S.M.	C.P.
01	03

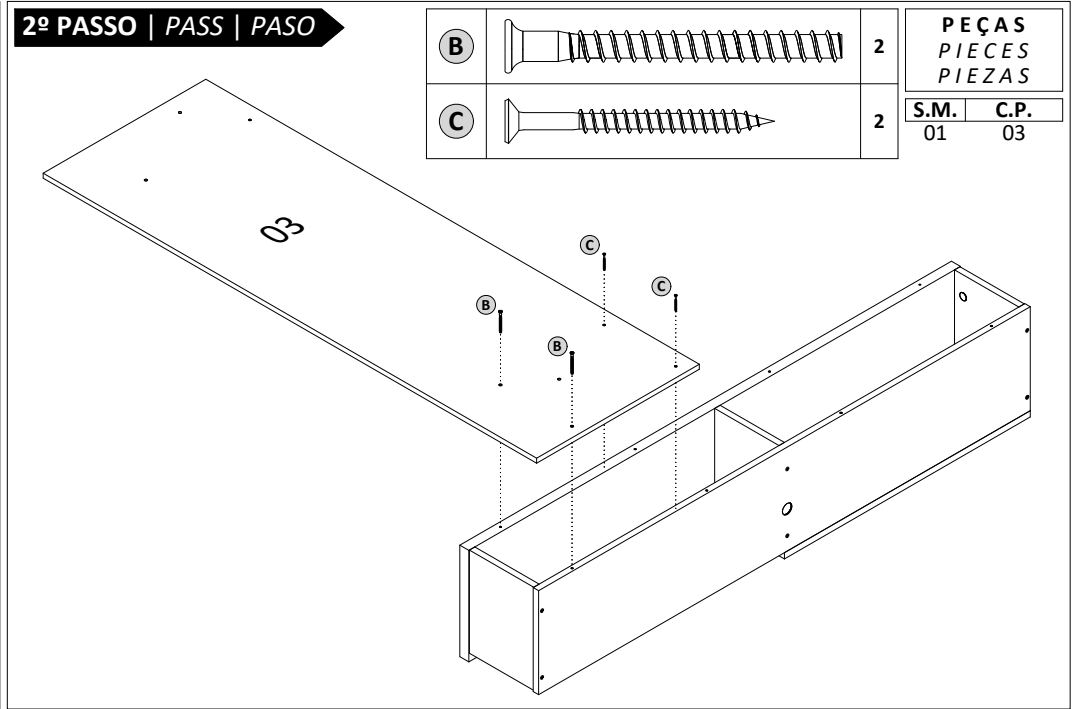

4º PASSO | PASS | PASO

PEÇAS
PIECES
PIEZAS

S.M.	C.P.
01	01

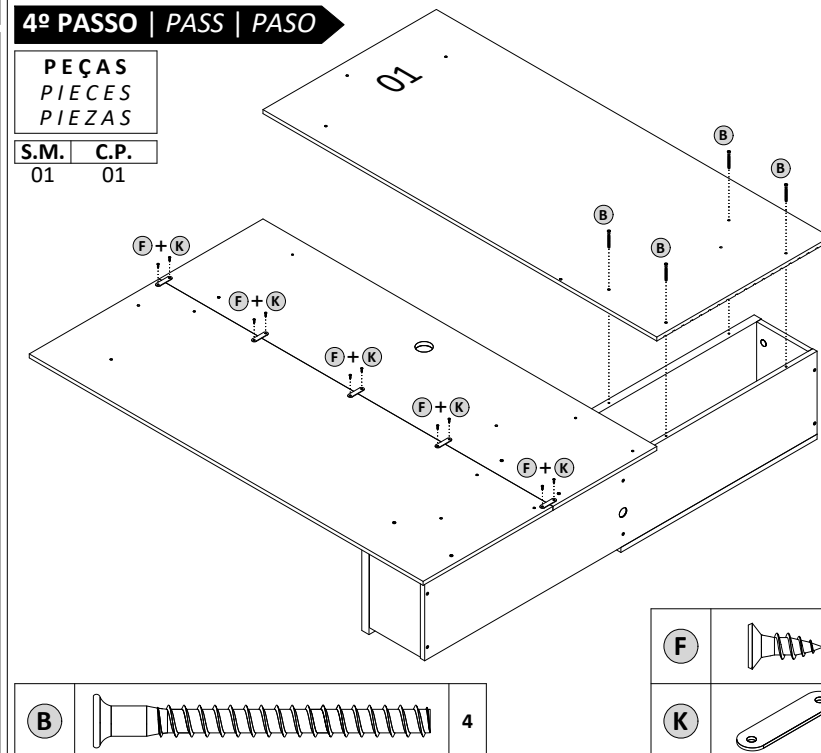

B		4
----------	--	---

F		10
K		5

Atenção!!!
Usar Parafuso 3,5x10 nos painéis.

Attention!!!
Fixing 3,5x10 screws on the panels.

Atención!!!
Utilizar tornillos 3,5x10 en los paneles.

5º PASSO | PASS | PASO

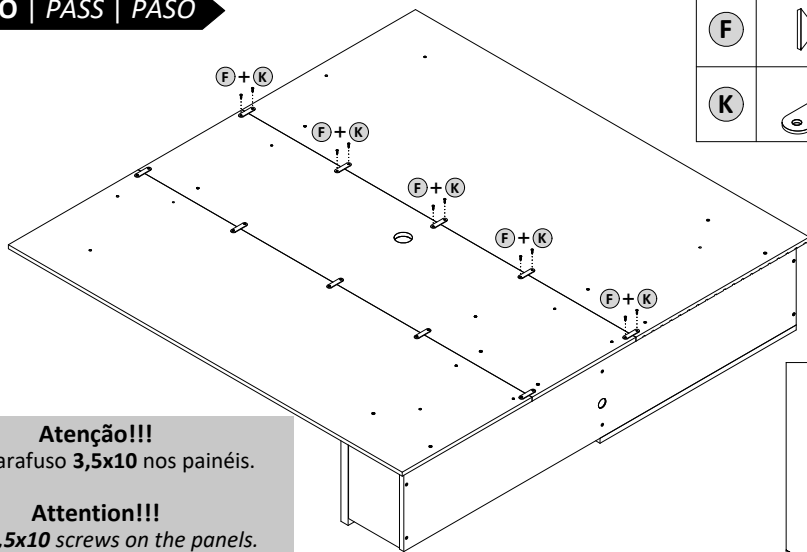

F		10
K		5

Atenção!!!
Usar Parafuso 3,5x10 nos painéis.

Attention!!!
Fixing 3,5x10 screws on the panels.

Atención!!!
Utilizar tornillos 3,5x10 en los paneles.

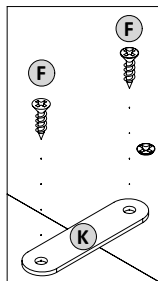

7º PASSO | PASS | PASO

PEÇAS PIECES PIEZAS	
S.M.	C.P.
01	08
02	09
03	08
04	11

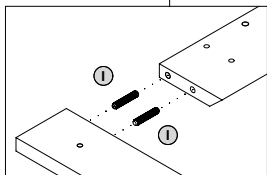
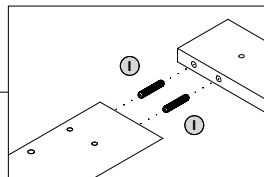
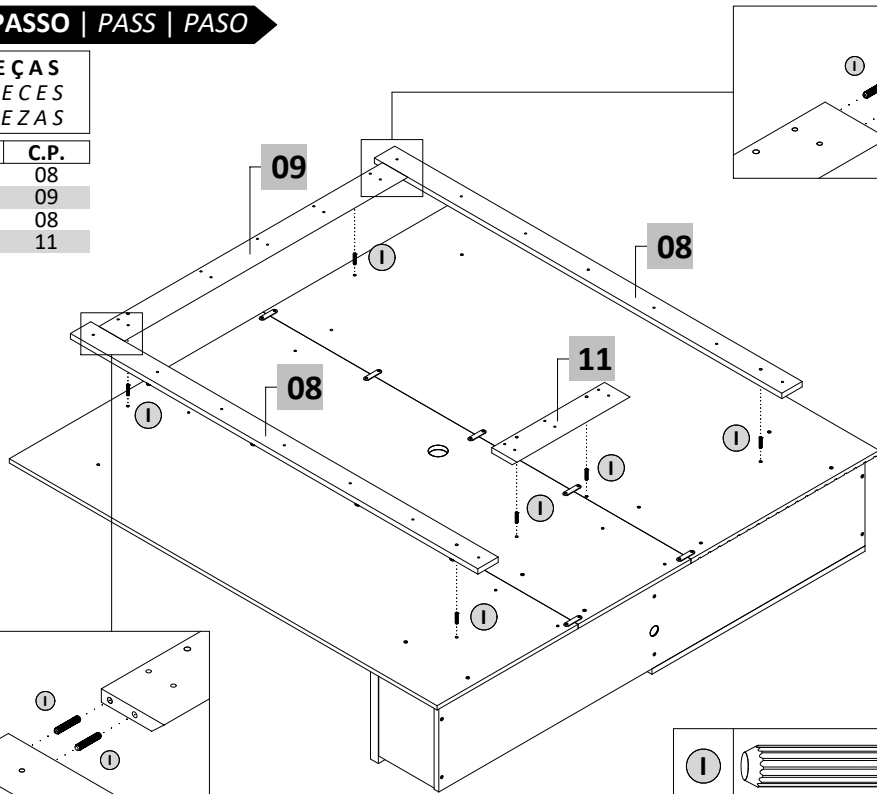

I		10
---	--	----

6º PASSO | PASS | PASO

ATENÇÃO
Passar cola [Q] nas peças nº 08, 09 e 11 antes de fixá-las nos painéis

ATTENTION
Pass [Q] glue on the 08, 09, 11 piece before fixing them to the panels

ATENCIÓN
Pasar pegamento [Q] en la pieza 08, 09, 11 antes de fijarlas en los paneles

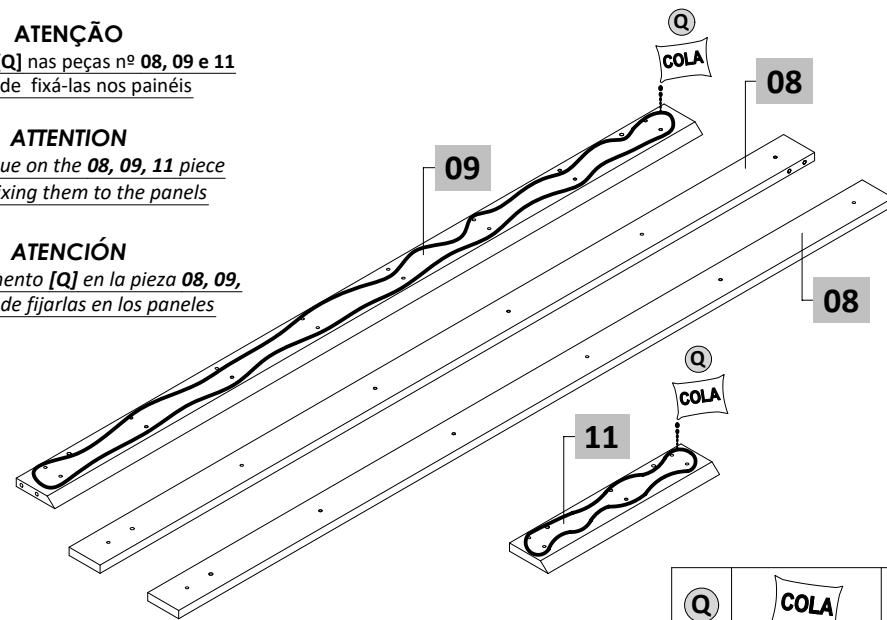

Q		2
---	--	---

8º PASSO | PASS | PASO

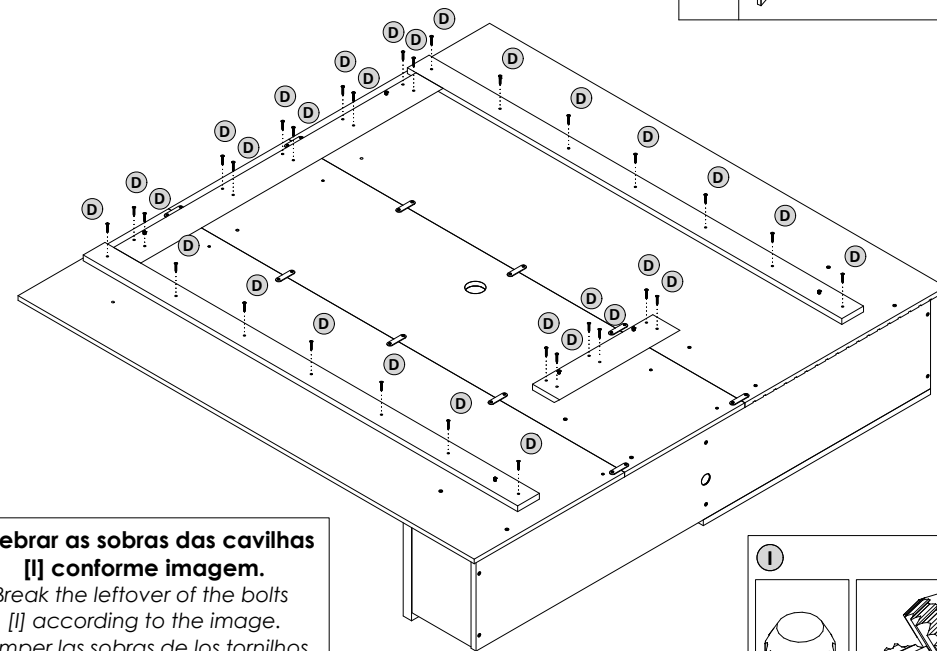

D		30
---	--	----

Quebrar as sobras das cavilhas [I] conforme imagem.
Break the leftover of the bolts [I] according to the image.
Romper las sobras de los tornillos [I] conforme imagene.

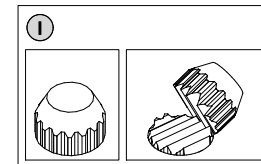

9º PASSO | PASS | PASO

PEÇAS
PIECES
PIEZAS

S.M.	C.P.
01	07

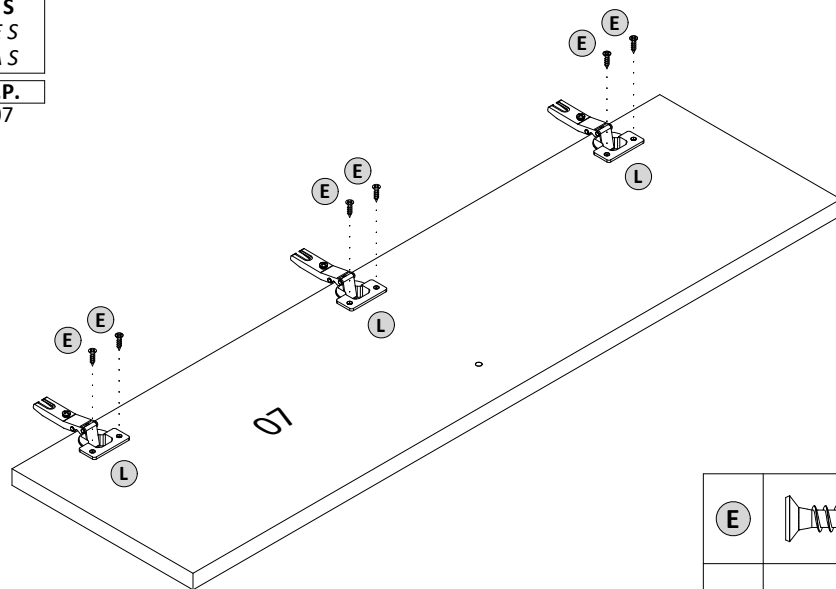

E		6
L		3

10º PASSO | PASS | PASO

N		2
---	--	---

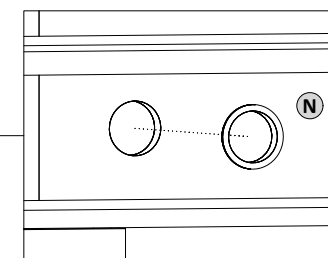
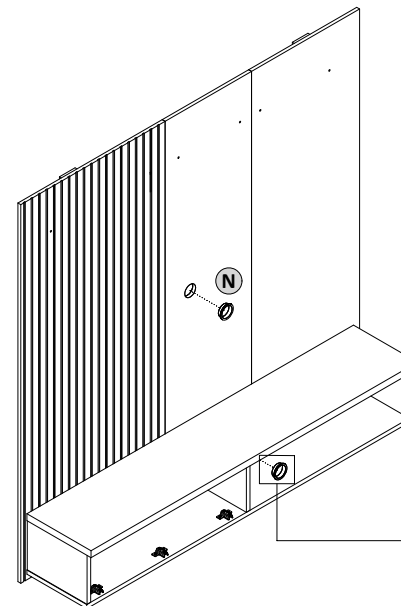

11º PASSO | PASS | PASO

M		1
---	--	---

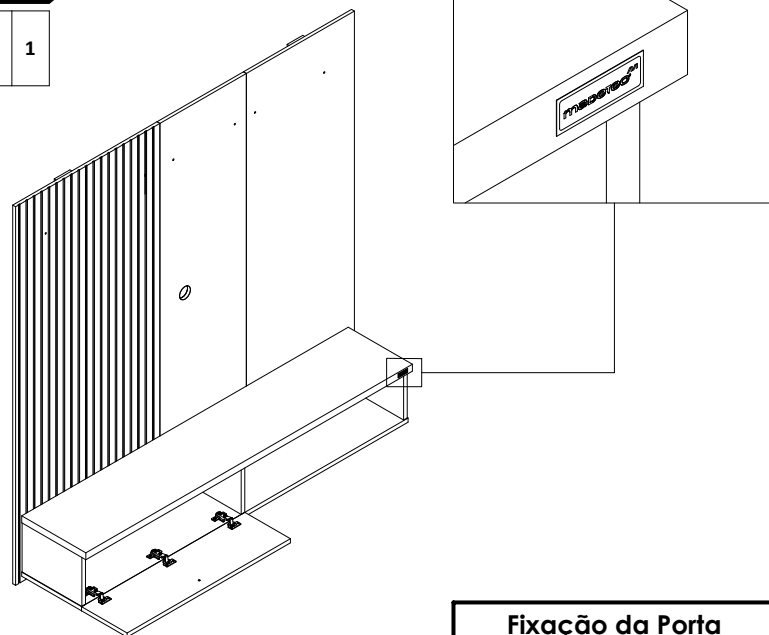

Fixação da Porta
Door fixing
Fijación de la puerta

12º PASSO | PASS | PASO

PEÇAS
PIECES
PIEZAS

S.M.	C.P.
1	14

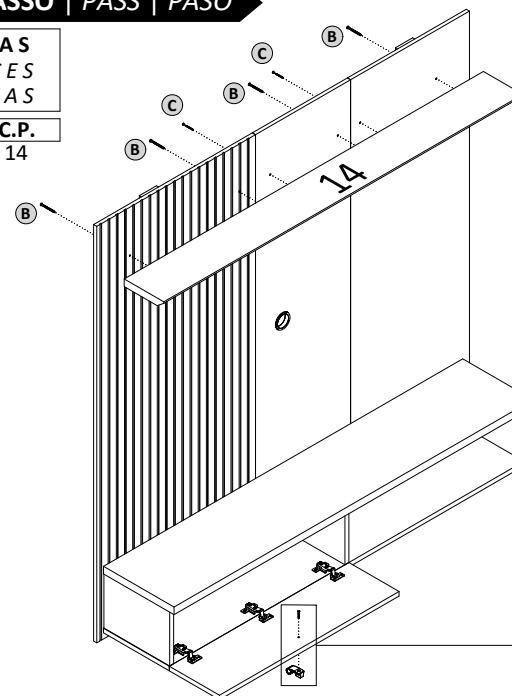

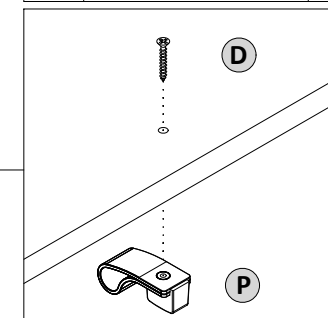

B		4
C		2
D		1
P		1



Fixação do Puxador
Fixing the handle
Fijación del tirador

13º PASSO | PASS | PASO

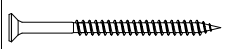
PEÇAS PIECES PIEZAS	
S.M.	C.P.
01	12
02	15
03	10

A		5
G		5

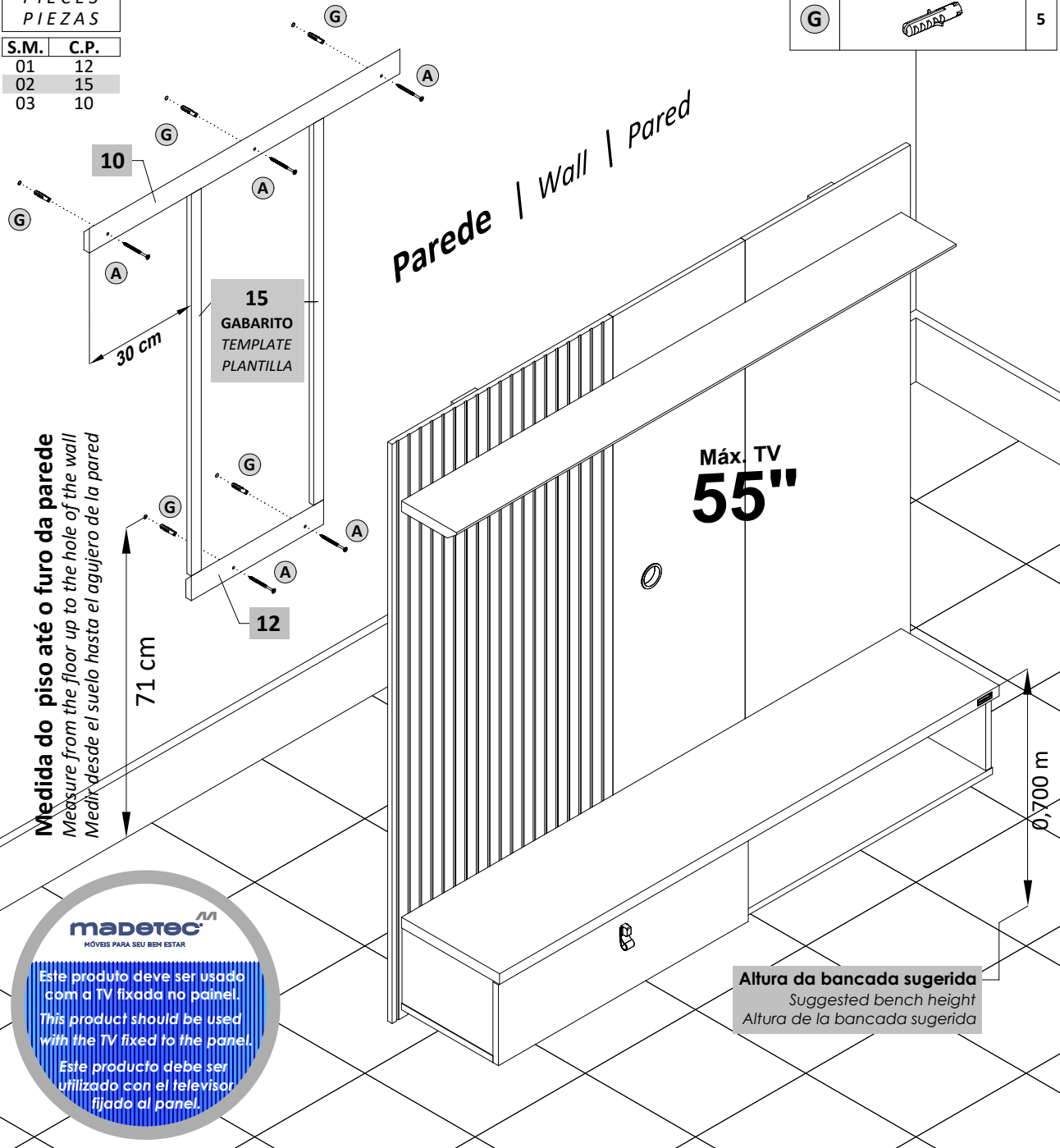

Parede | Wall | Pared

Máx. TV
55"

Altura da bancada sugerida
Suggested bench height
Altura de la bancada sugerida

Medida do piso até o furo da parede
Measure from the floor up to the hole of the wall
Medir desde el suelo hasta el agujero de la pared



Este produto deve ser usado com a TV fixada no painel.
This product should be used with the TV fixed to the panel.
Este producto debe ser utilizado con el televisor fijado al panel.

ASPECTO FINAL | FINAL ASPECT

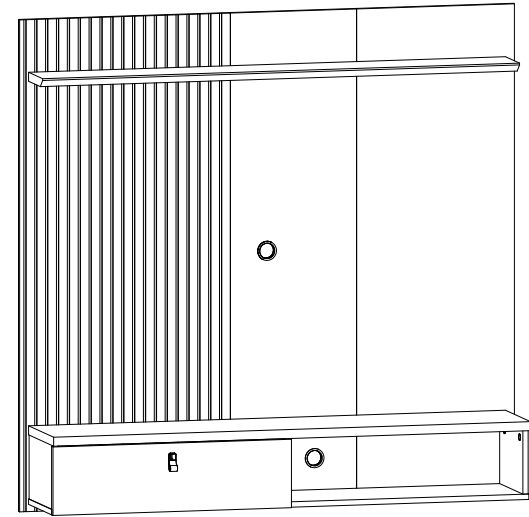

→ 1,410 m ↑ 1,365 m ↯ 0,290 m
Dimensão do Produto:
Product dimensions:
Dimensiones del producto:

**ATENÇÃO
WARNING
ATENCIÓN**

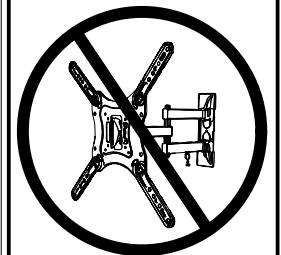

PRODUTO NÃO INDICADO PARA USO DE SUPORTE ARTICULADO PARA TV
PRODUCT NOT INDICATED FOR SUPPORT USE ARTICULATED FOR TV
PRODUCTO NO INDICADO PARA USO DE SOPORTE ARTICULADO PARA TV

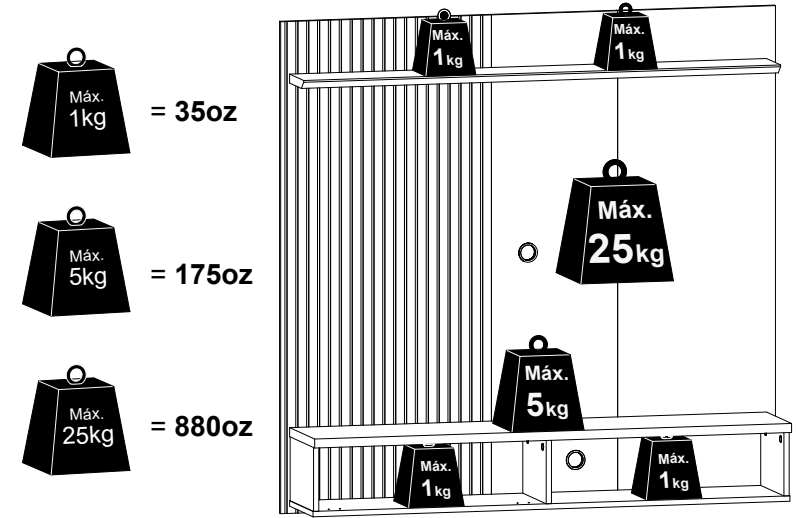

CUIDADOS ESPECIAIS | SPECIAL CARES | CUIDADOS ESPECIALES:

LIMPEZA: Pano limpo umedecido em água e sabão neutro - **BRILHO:** Flanela seca
CLEANING: Clean cloth humidified in water and neutral soap - **SHINE:** Dry flannel
LIMPIEZA: Tela limpia humedecida en la agua y el jabón neutro - **BRILLO:** Franela seca