

DIMENSÕES DO PRODUTO / PRODUCT DIMENSIONS / DIMENSIONS PRODUCT - WxDxH / LxPxA - 1800 X 352X 1800

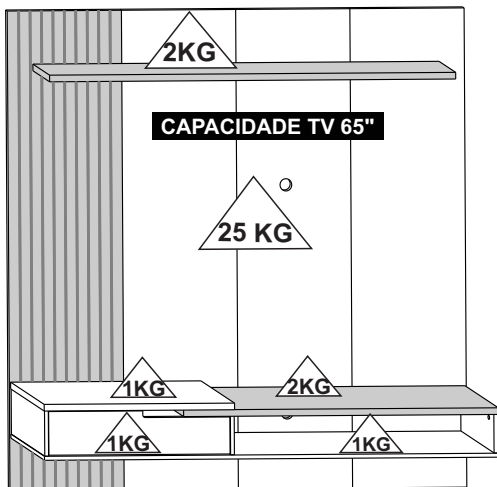

PEÇAS NUMERADAS / NUMBERED PARTS / PIEZAS NUMERADAS  
EX: 1915X-X 05(peça/ piece/ pieza number)

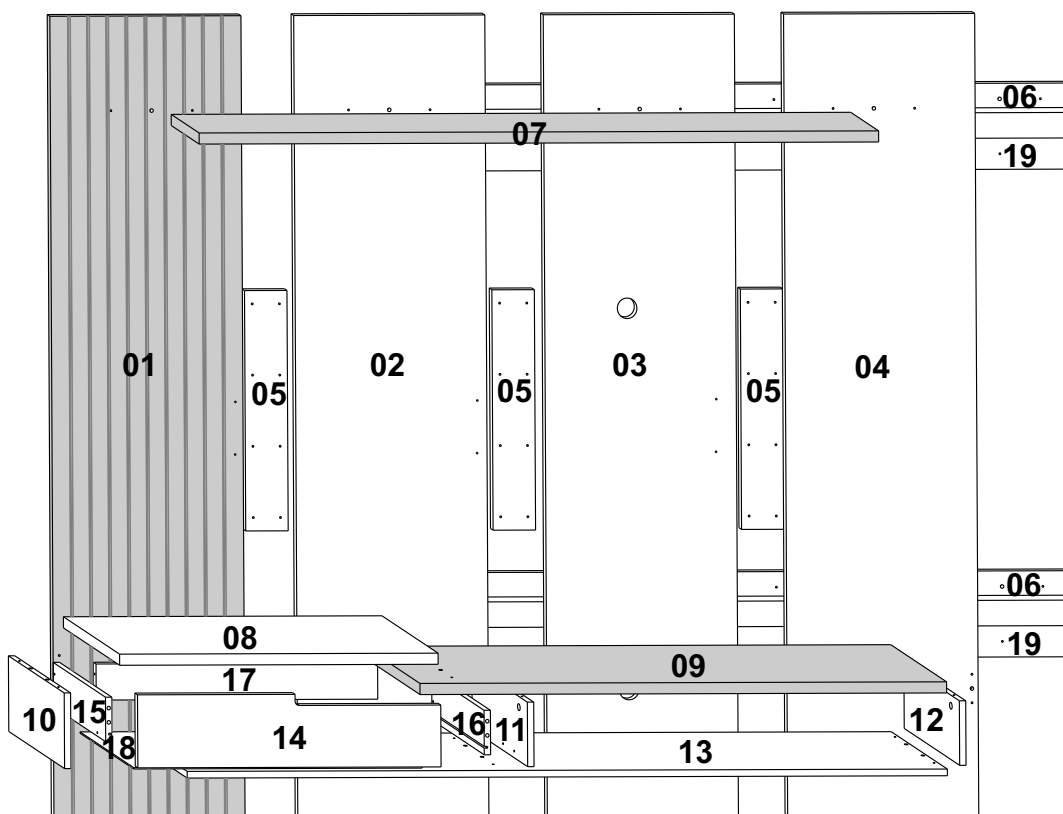

**ATENÇÃO / ATTENTION / ATENCION**

Nunca utilizar óleos, lustra móveis, produtos abrasivos, saponáceos, esponja de aço e outros.

Never use oils, furniture polish, abrasive products, soaps, steel sponge and others.

Nunca use aceites, pulimentos, abrasivos, jabones, esponja de acero y otros.

**CUIDADOS ESPECIAIS/ SPECIAL CARE/ CUIDADOS ESPECIALES**

- Evitar expor o móvel ao sol, e em lugares úmidos.
- Limpar com flanela seca ou com pano levemente umedecido em água.
- Avoid exposing the furniture to the sun, and in damp places.
- Clean with dry flannel or lightly cloth moistened with water.
- Evite exponer los muebles al sol y en lugares húmedos.
- Limpiar con flanela seca o un paño ligero, humedecido con agua.

Ferramentas necessárias  
(não fornecidas)



Necessary tools  
(not provided)

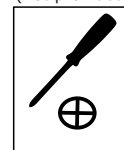

Herramientas Necesarias  
(No proporcionadas)

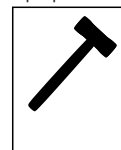

**MONTAR O PRODUTO SOBRE A EMBALAGEM, EVITANDO DANOS NA PINTURA. ACONSELHAMOS QUE A MONTAGEM DO PRODUTO SEJA POR UM PROFISSIONAL.**

**SETUP THE PRODUCT ON TOP OF THE PACKAGING, AVOIDING DAMAGE TO THE PAINT. WE RECOMMEND THAT THE INSTALLATION IS DONE BY A PROFESSIONAL.**

**MONTAR EL PRODUCTO EN EL PAQUETE, EVITAR LESIONES EN PINTURA. AVISAMOS QUE EL MONTAJE DEL PRODUCTO SEA UN PROFESIONAL.**

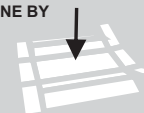

**MEDIDA UTILIZADA EM MM / UNIT MEASURE USED / IS MILLIMETERS (MM)**

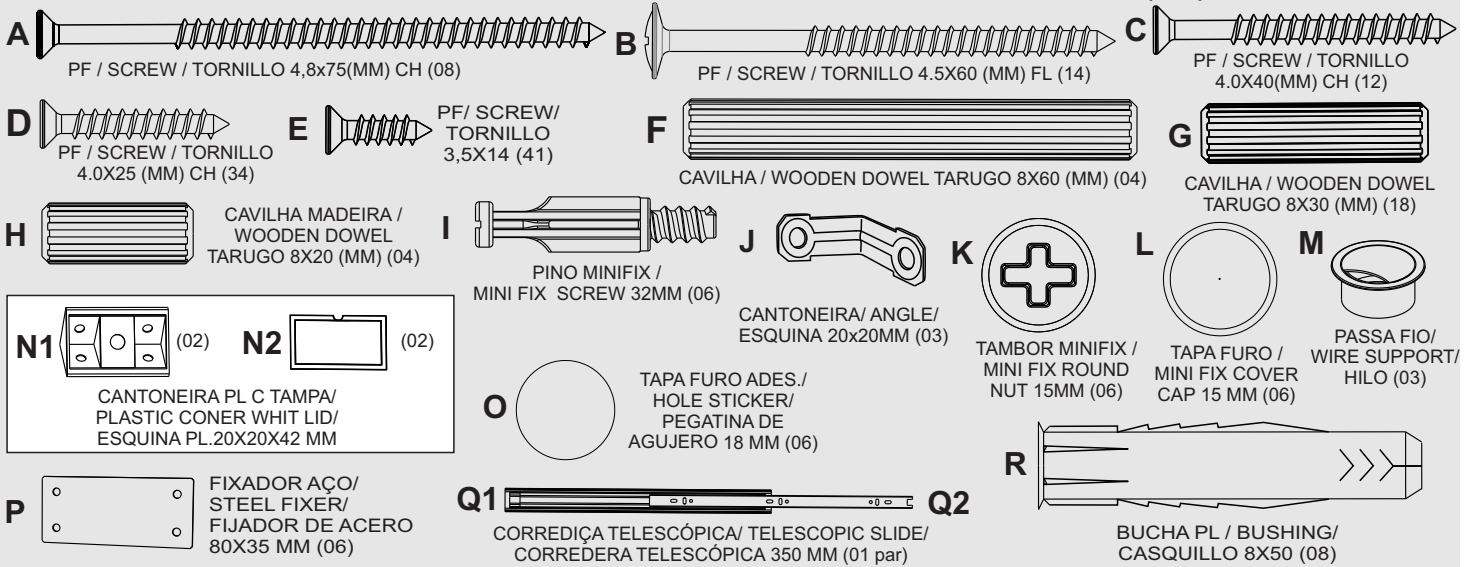

ITEM		DESCRIÇÃO DA PEÇAS / DESCRIPTION OF PARTS / UNIT MEASURE USED IS MILLIMETERS (MM)	CORES PRODUTO / PRODUCT COLORS / COLORES PRODUCTO				
COD	Nº	NOME/NAME/NOMBRE	MEDIDAS / MEASURES (MM)	TIPO TYPE	QUANT AMOUNT CANTIDAD	OFF WHITE- Cód 06/ CEDRO- Cód. 03	PRETO- Cód 07/ CEDRO- Cód 03
18641	1	PAINEL FRISADO/ PANEL	1800x450x15	MDF	1	01/03	01/03
18642	2	PAINEL CENT. ESQ/ CENT PANEL	1800x450x15	MDP	1	02/06	02/07
18643	3	PAINEL CENT. DIR/ CENT PANEL	1800x450x15	M5DP	1	03/06	03/07
18644	4	PAINEL DIR/ PANEL	1800x450x15	MDP	1	04/06	04/07
18645	5	REFORÇO TRAS/ REAR REINFORCEMENT/ REFUERZO TRASERO	540x100x15	MDF	3	05/06	05/07
18646	6	RÉGUA FIXA SUP-INF/ FIXED RULER TOP BOTTOM/ REGLA FIJA ARRIBA INFERIOR	1650x70x15	MDF	2	-----	-----
18647	7	PRATEL. SUP./ TOP SHELF/ ESTANTE SUP.	1600x160x25	MDP	1	07/03	07/03
18648	8	TAMPO ESQ./ LEFT TOP/ ARRIBA IZQUIERDO	750x322x25	MDP	1	08/06	08/07
18649	9	TAMPO DIR./ RIGHT TOP/ ARRIBA DERECHO	1240x320x25	MDP	1	09/03	09/03
18650	10	LAT. ESQUERDA/ LEFT SIDE/ LADO IZQUIERDO	320x170x15	MDP	1	10/06	10/07
18651	11	DIVISOR/ DIVIDER	318x145x15	MDP	1	11/06	11/07
18652	12	LAT. DIREITA/ RIGHT SIDE/ LADO DERECHO	318x145x15	MDP	1	12/06	12/07
18653	13	BASE	1790x322x15	MDP	1	13/06	13/07
18654	14	FRENTE GAV./DRAWER FRONT / FRENTE DE CÁJON	714x164x15	MDF	1	14/06	14/07
18655	15	LAT.GAV.ESQ./LEFT/DRAW. SIDE/LAD. CAJ.IZQ.	300x100x15	MDP	2	15/06	15/07
18656	16	LAT.GAV.DIR./ /DRAW. SIDE/LAD. CAJ.DER.	300x100x15	MDP	1	16/06	16/07
18657	17	CONT. FRENT. GAV./FRONT AGAINST DRAWER	663x100x15	MDP	1	17/06	17/07
18658	18	FUNDO GAV./ DRAWER BACKGROUND/ FONDO CÁJON	679x308x03	TRI	1	18/06	18/07
18659	19	RÉGUA PAREDE/BOTTOM AND TOP WALL RULER/ REGLA DE PARED INFEIOR Y SUPERIOR	1650x70x15	MDF	2	-----	-----
18637	A	PF./ Screw/ Tornillo 4,8X75 CH (MM)			08		
438	B	PF./ Screw/ Tornillo 4,5X60 FL (MM)			14		
434	C	PF./ Screw/ Tornillo 4,0x40(MM) CH (MM)			12		
986	D	PF./ Screw/ Tornillo 4,0X25 CH (MM)			34		
8121	E	PF./ Screw/ Tornillo 3,5x14 CRR (MM)			41		
137	F	Cavilha / Wooden Dowel / Tarugo 8x60 (MM)			04		
2921	G	Cavilha / Wooden Dowel / Tarugo 8x30 (MM)			18		
532	H	Cavilha / Wooden Dowel / Tarugo 8x20 (MM)			04		
132	I	Pino Minifix / Minifix Screw 32 (MM)			06		
508	J	Cantoneira/ Angle/ Esquina 20x20 mm			03		
7125	K	Tambor Minifix / Minifix Round Nut 15(MM)			06		
8456	L	Tampa Minifix / Minifix Cover Cap 15(MM)fix 15 MM			06	-----	PRETO
5785	M	Passa Fio / Wire Support/ Hilo 46 MM			02	BRANCO	PRETO
15175	N1/N2	Cantoneira PL/Plast. corner with lid / Esquina PL. 20X20X42(MM)			02	-----	CINZA
13877	O	Tapa Furo Ades./ Hole Sticker/ Pegatina de Agujero 18 mm			06	GELO	-----
737	P	Fixador Aço/ Steel Fixer/ Fijador de Acero 80X35 MM			06	-----	-----
13036	Q1/Q2	Corred.Telescópica/Metallic Slid 300 (MM) (01 Pair)			02	CINZA	CINZA
2922	R	Bucha Pl/ Bushing/ Casquillo 8X50 Cinza			08	-----	-----
		Certif. de Garant. / Warranty Certif.					

**PREPARAÇÃO DE PEÇAS / PARTS PREPARATION / PREPARACION DE PIEZAS**

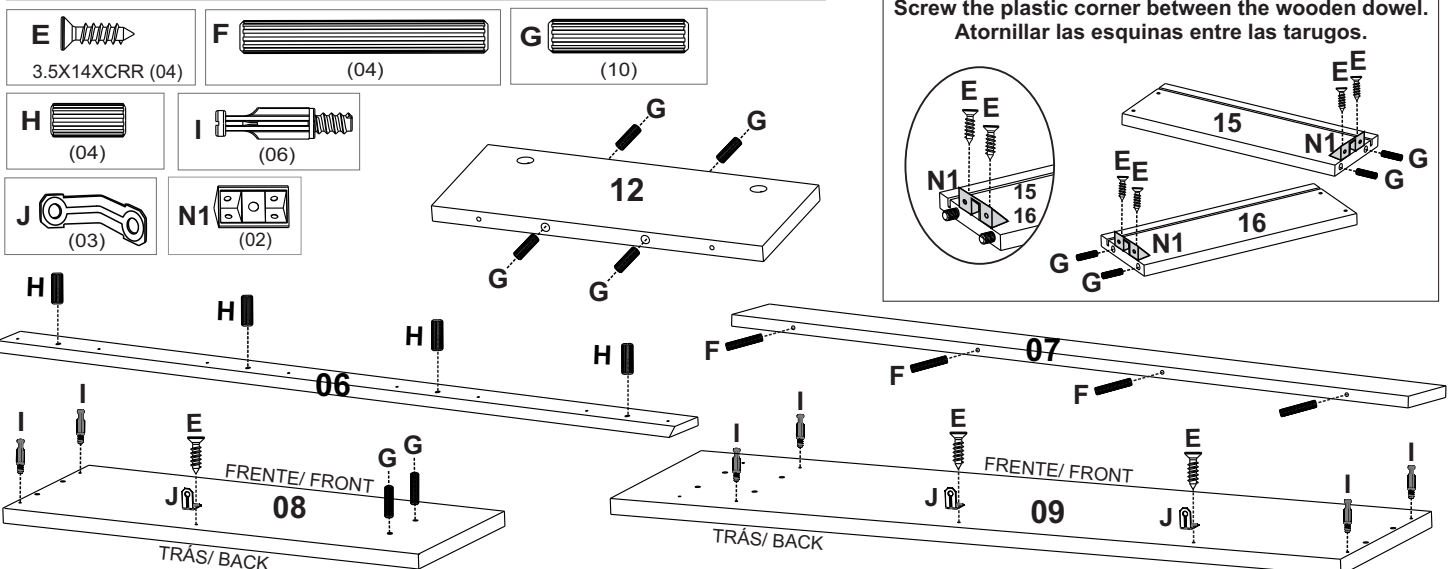



(08)



Q1

(02)

• Fixação da Corrediça / Slide Fixation / Fijación de Corredera



- Vire a corredeira e puxe a peça Q2 até o final do seu curso, aperte a trava para soltá-la, retire e parafuse Q1 nas peças 15 e 16.
- Turn the slide and pull the Q2 piece to the end of its course, tighten the lock to release it, remove and screw Q1 on parts 03 and 05.
- Gire la corredera y tire de la pieza Q2 hasta el final de su recorrido, apriete el bloqueo para liberarlo, retire y atornille Q1 las piezas 15 y 16.

• Parafusar nos furos oblongos / Screw into oblongs holes / Atornillar en agujeros oblongos

Q1 Fixar Q1 nas peças/ Fix parts/ Reparar piezas 15 e 16.

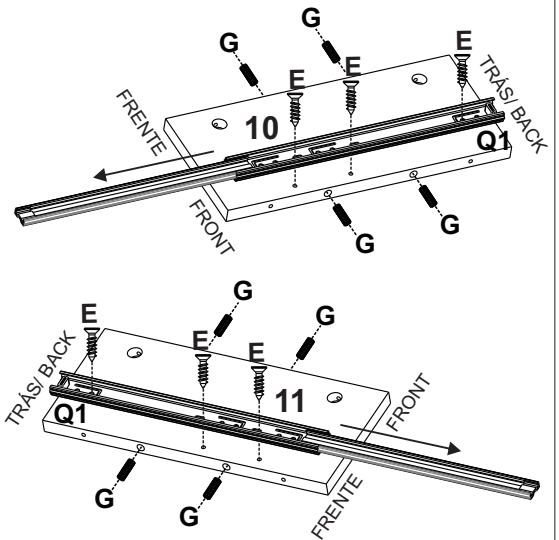
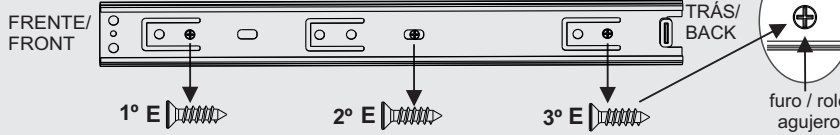

Obs: As peças pintadas nos passos são apenas ilustrativas. The parts painted in the steps are illustrative only. Las partes pintadas en los pasos son solo ilustrativas.

1

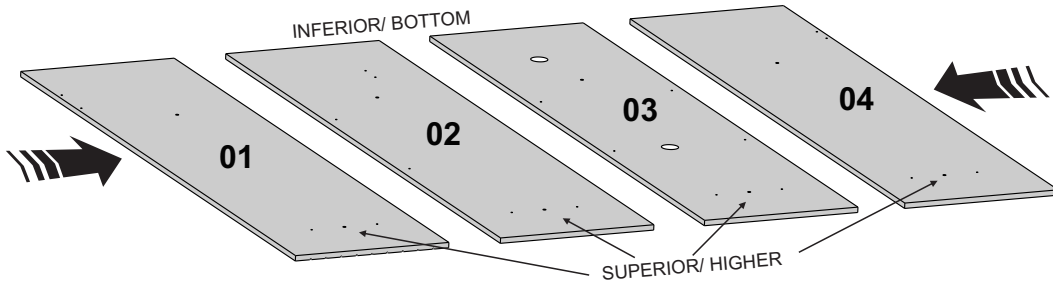

2

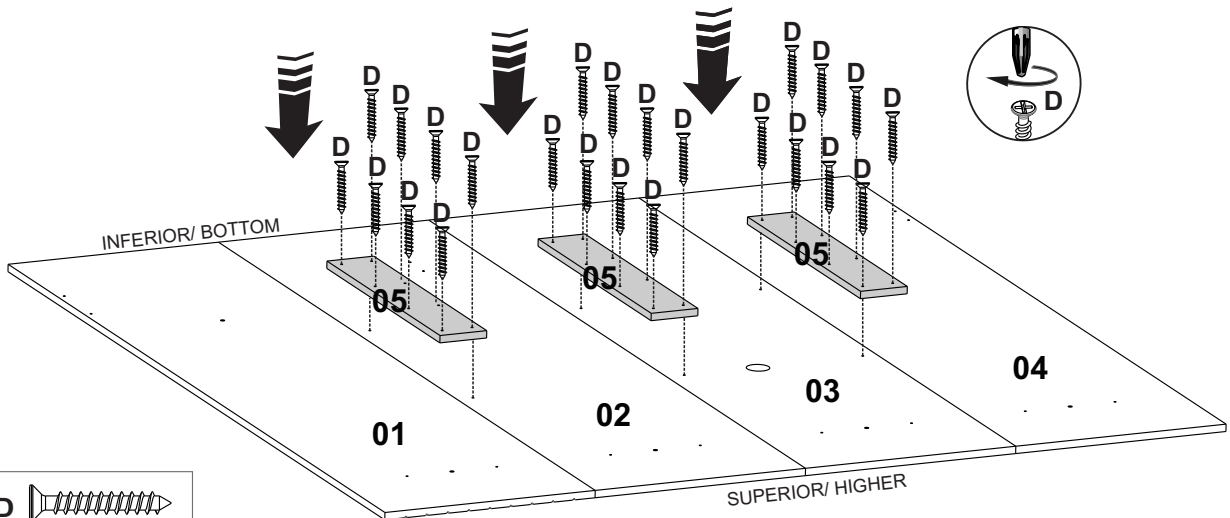

D=24

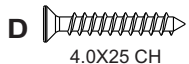

3

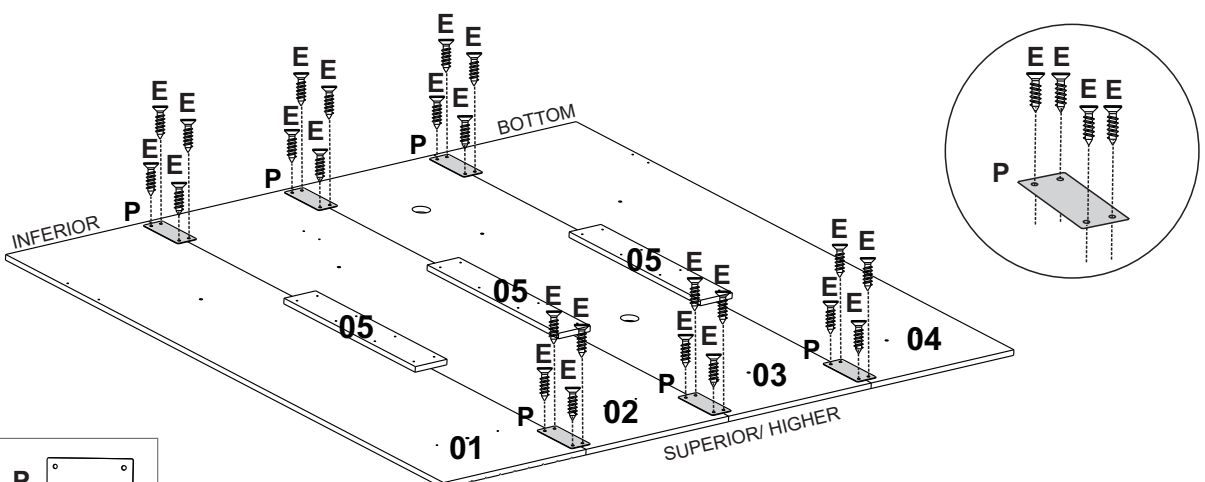

E=24

P=06

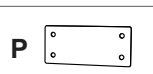
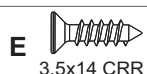

4

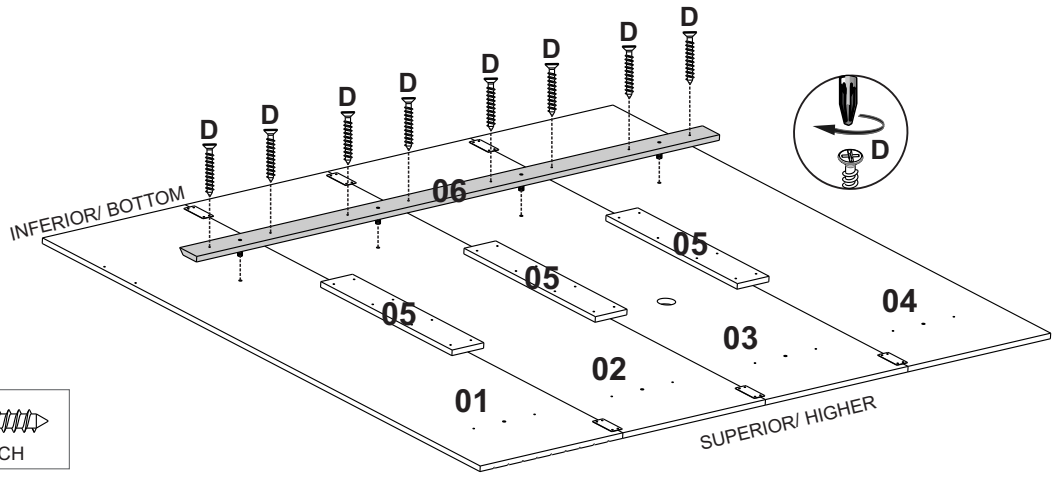

**D=08**

4.0X25 CH

5

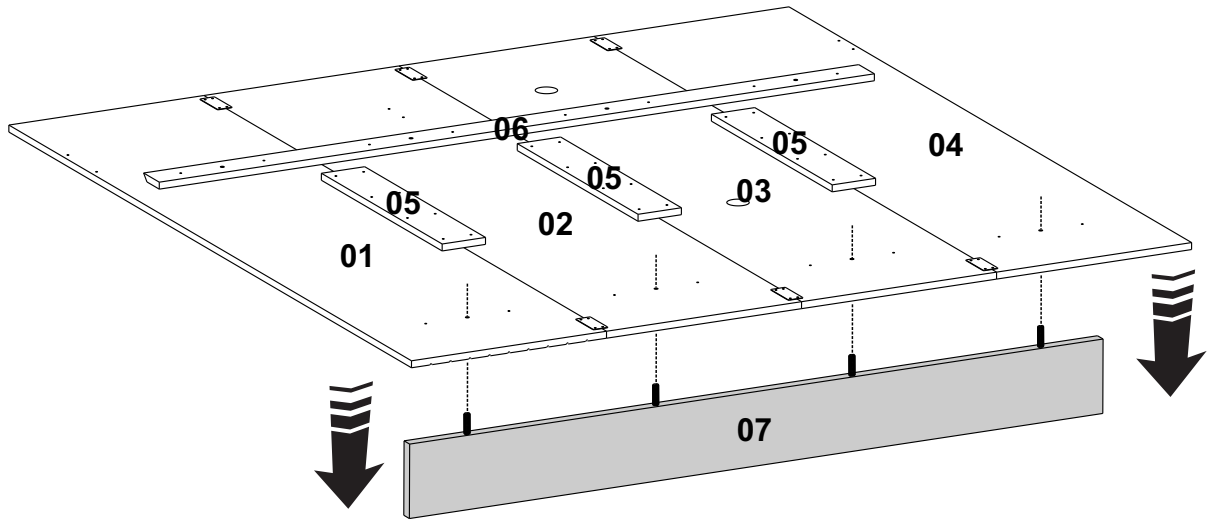

6

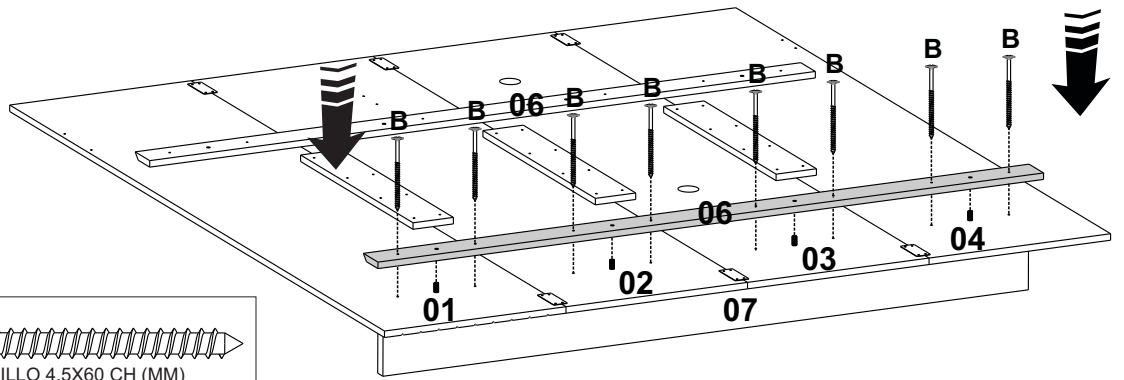

**B=08**

PF / SCREW / TORNILLO 4.5X60 CH (MM)

7

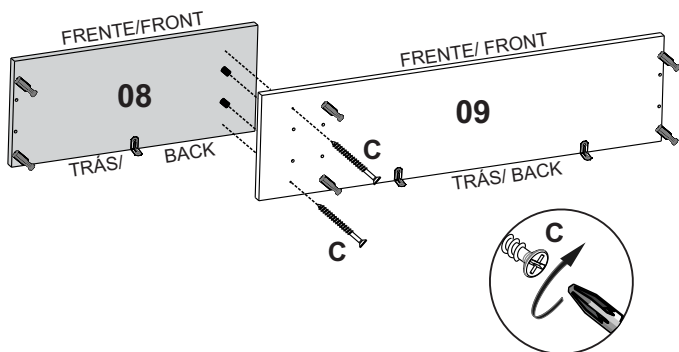

**C=02**

4.0X40 CH

8

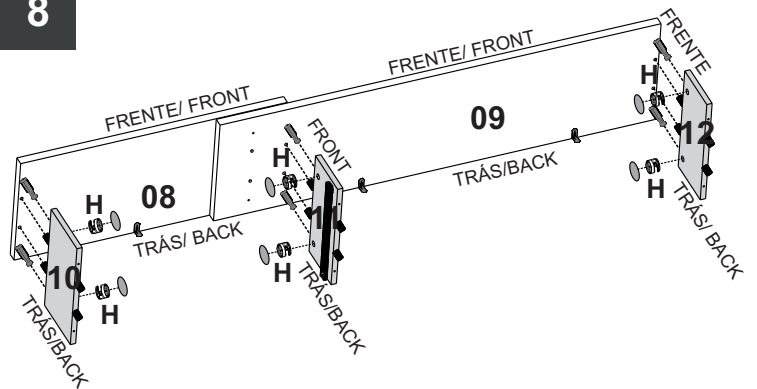

**H=06**  
**L ou O=06**

K

L ou O

9

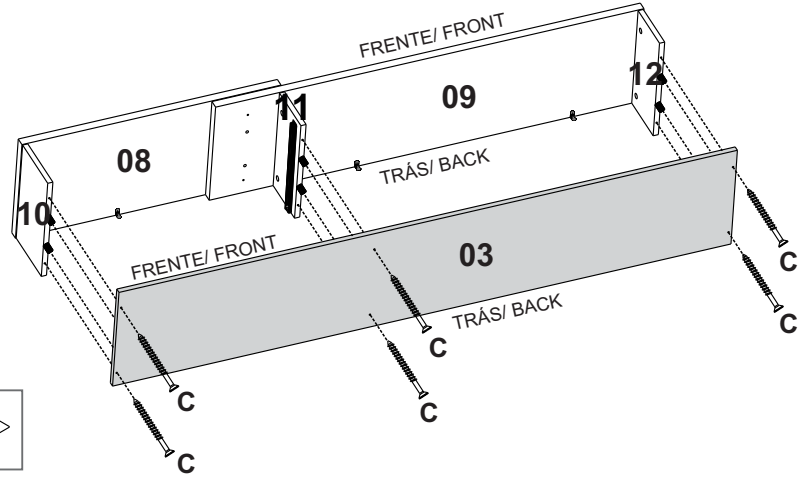

C=06

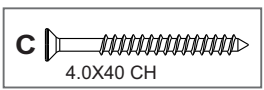

10

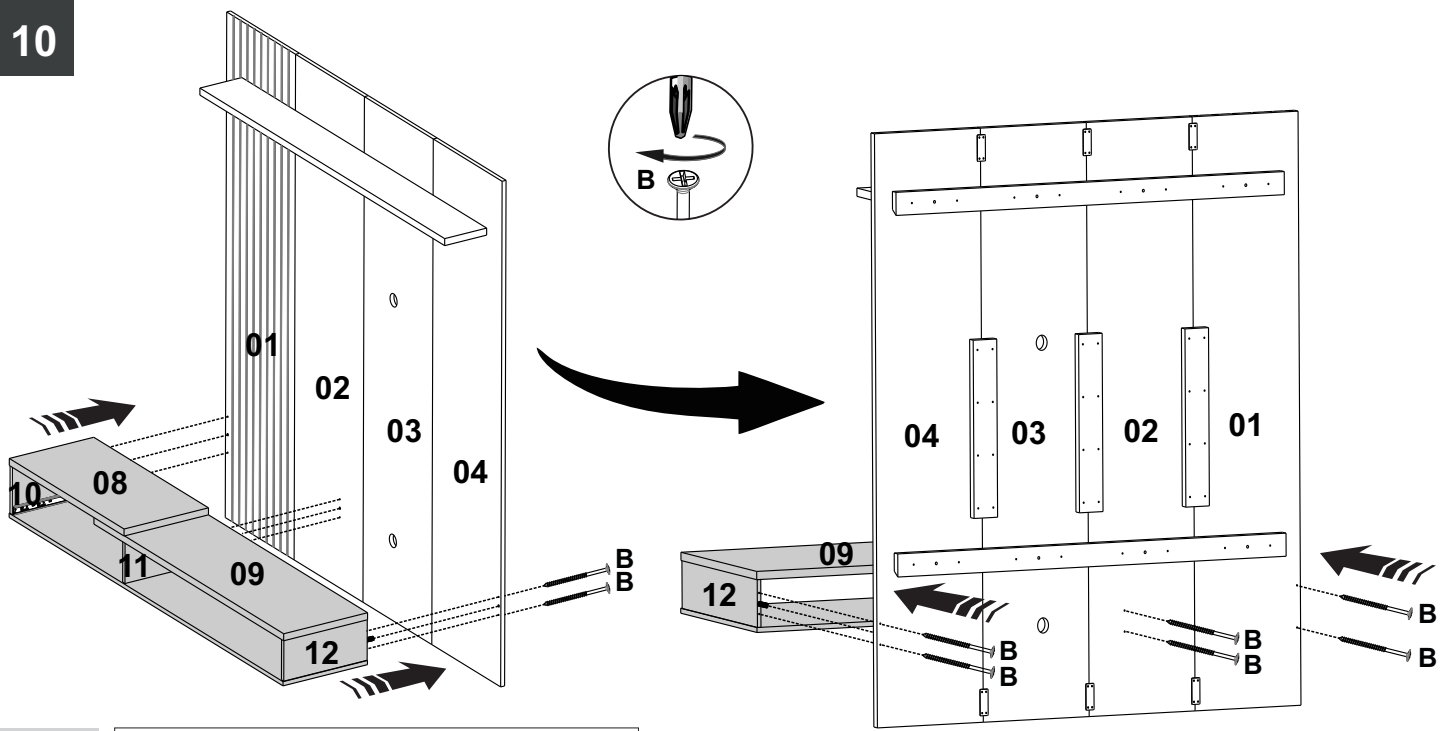

B=06



11

MONTAGEM GAVETA / ASSEMBLY OF THE DRAWER / MONTAJE LE CÁJON

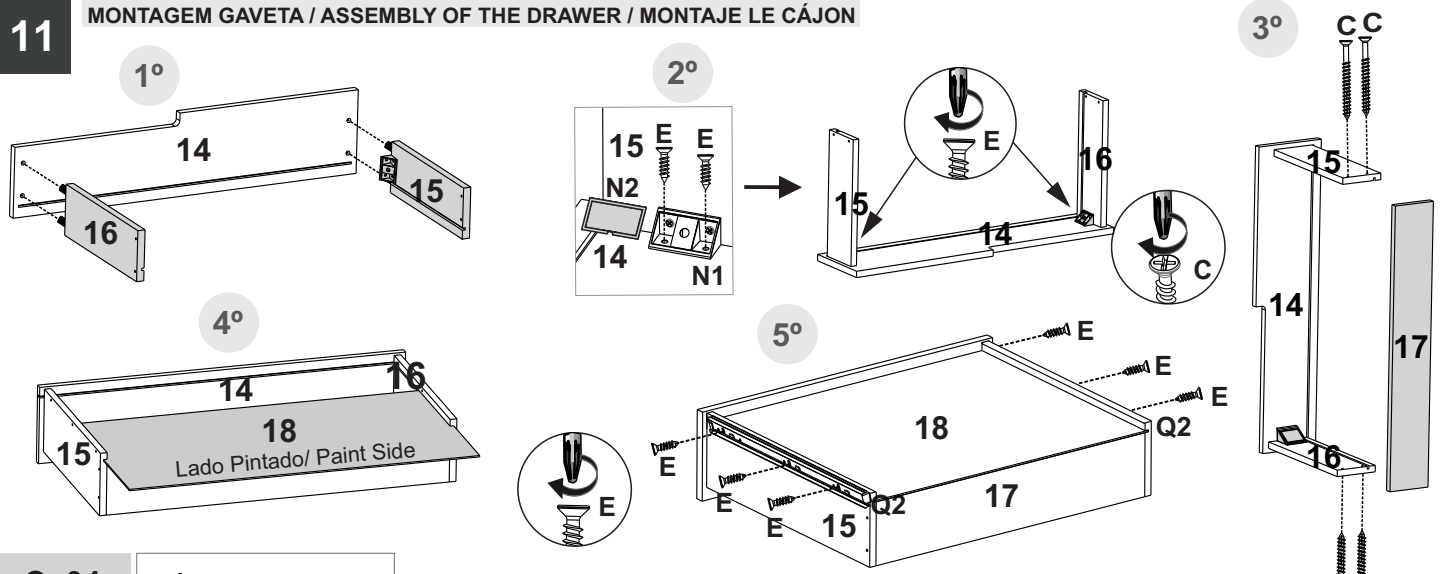

C=04  
E=10  
N2=02  
Q2=02

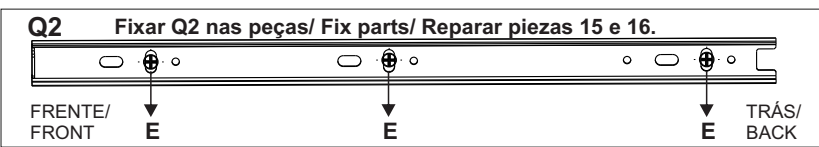
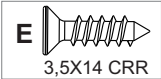
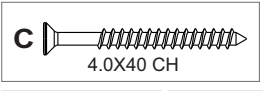

12

Encaixe dos chanfros  
Fitting the chamfer  
Colocación de los chaflán

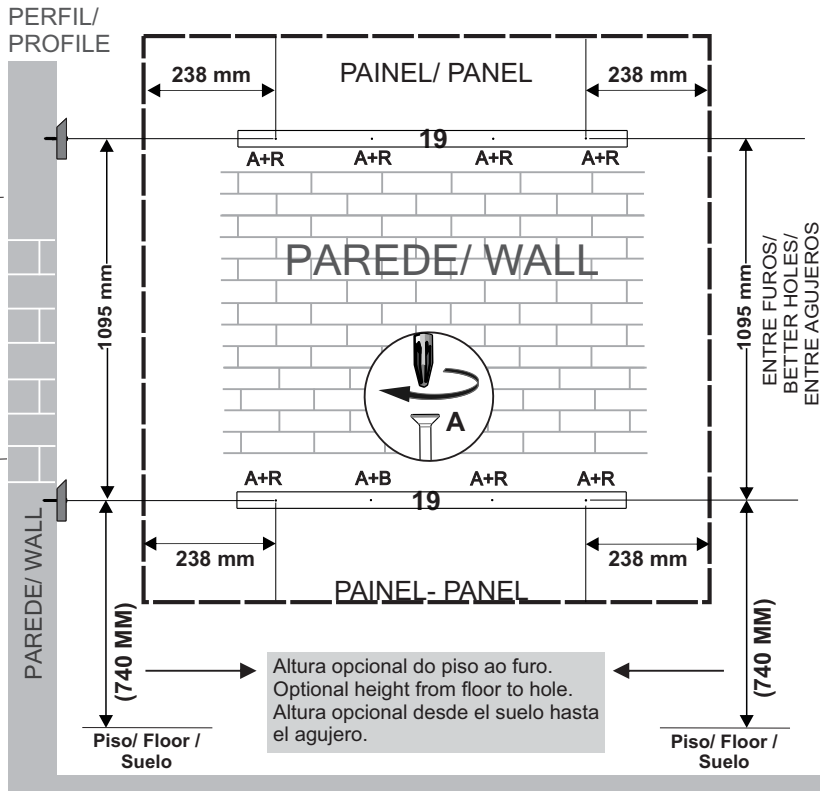
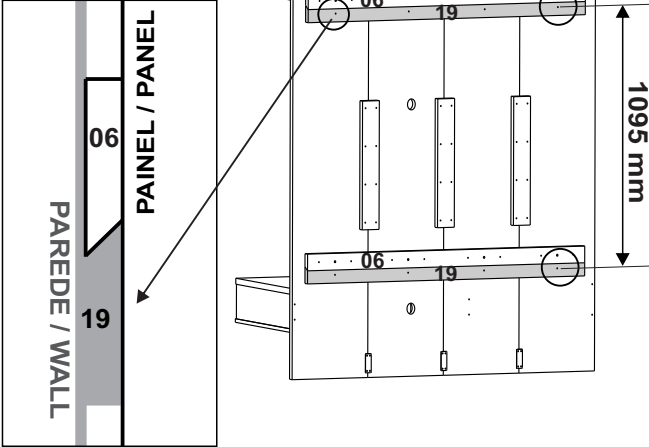

VISUALIZAÇÃO / VIEW / VISTA

ATENÇÃO / ATTENTION / ATENCION

Verifique se as régulas encaixaram corretamente.  
Check if the rulers fit correctly.  
Comprobar si las reglas encajan correctamente.

A=08  
R=08

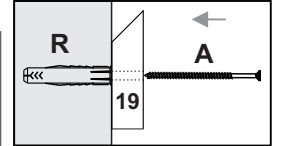
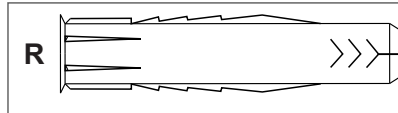
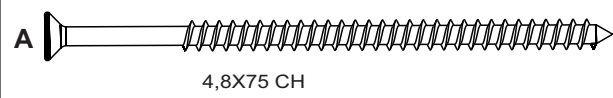

13

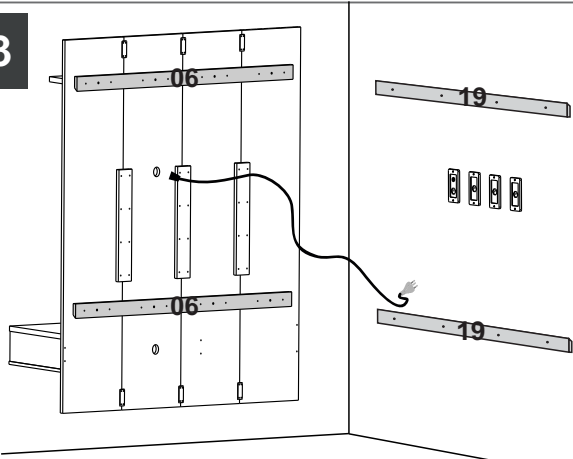

14

E=03

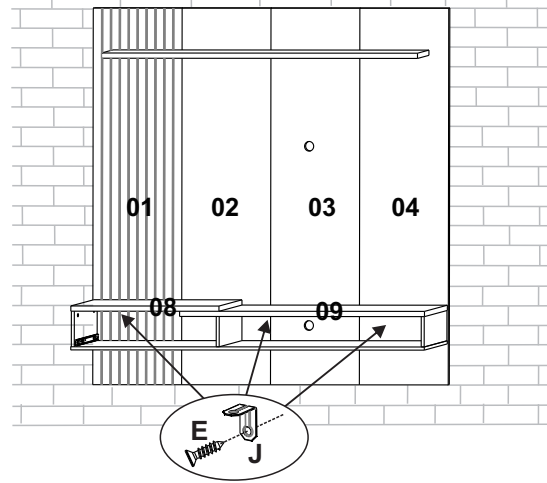

15

M=02

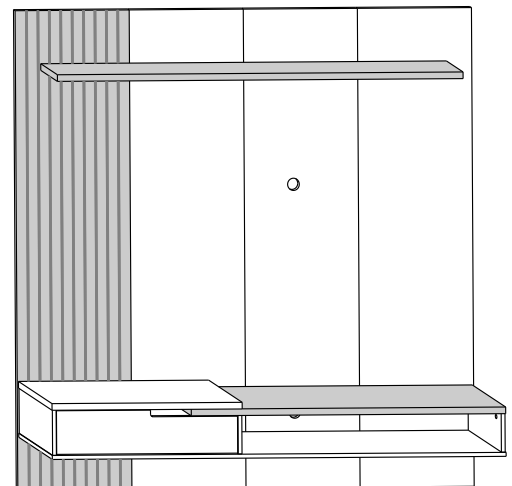
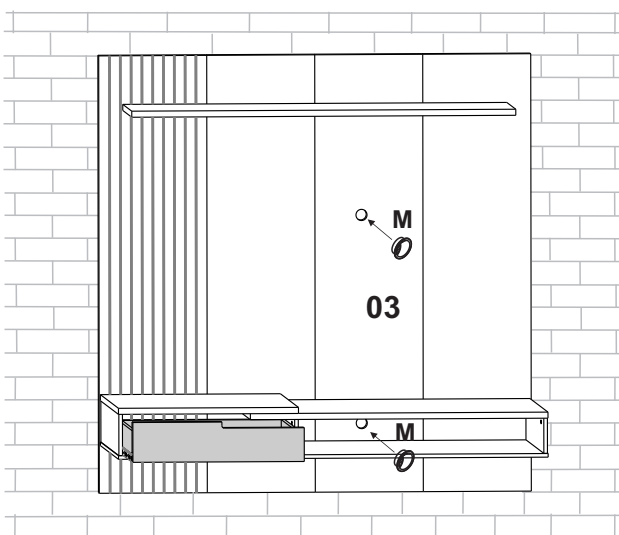

NOTA / NOTE

Não nos responsabilizamos por acidentes, se a instalação do móvel não estiver com os procedimentos deste Manual e não for realizado por pessoa habilitada. We are not responsible for accidents if the installation of the furniture is not in accordance with the procedures in this Manual and is not carried out by a qualified person. No nos hacemos responsables de accidentes si la instalación de los muebles no se realiza de acuerdo con los procedimientos de este Manual y no es realizada por una persona calificada.