

Linea Brasil

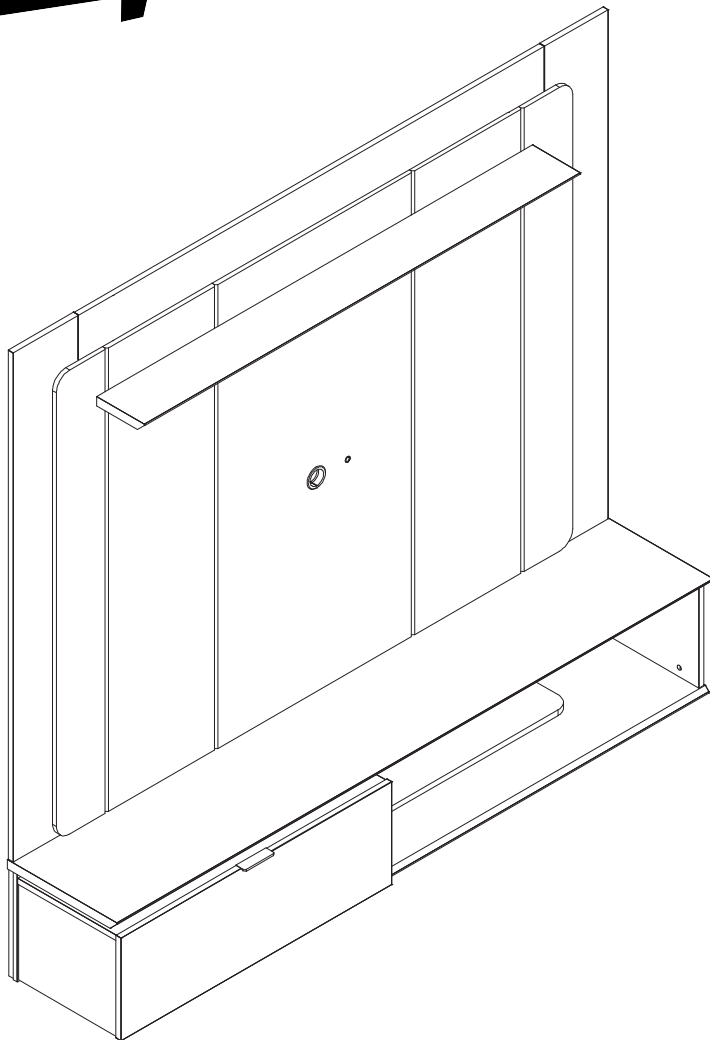

PAINEL HOME LUGANO

V-1 02/08/24

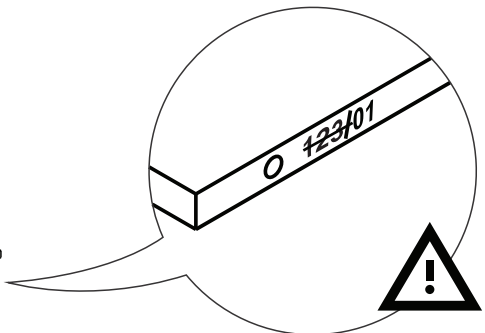
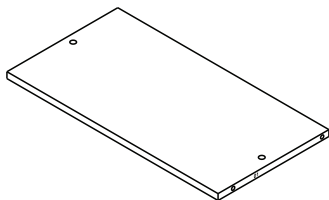
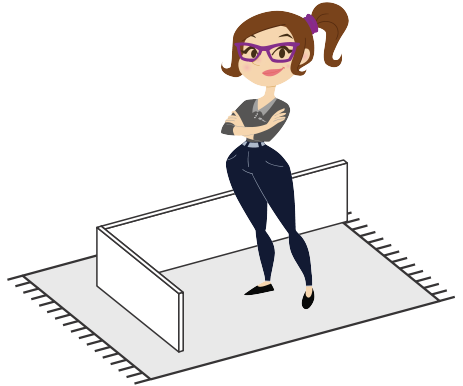
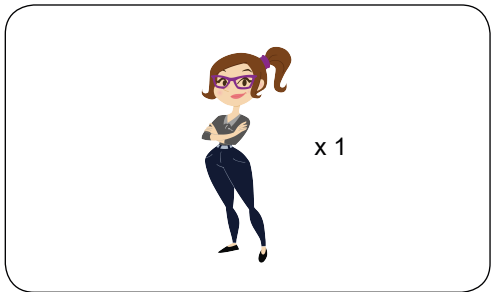
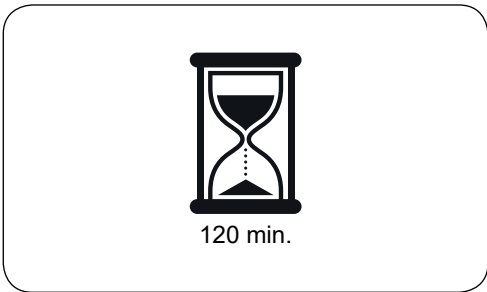
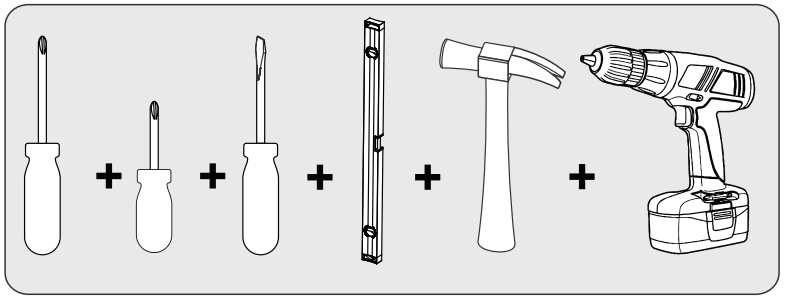
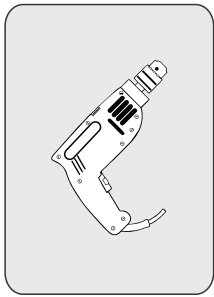

Nossos produtos são garantidos por 90 dias contra defeitos de fabricação. Ao constatar um problema coberto pela garantia, entre em contato com a loja onde o produto foi comprado. Ela estará capacitada para atendê-lo da melhor forma diante de cada caso. Reclamações de garantia somente poderão ser atendidas se o termo de garantia for apresentado no ato de reivindicação, acompanhado de sua nota fiscal de compra.

Nuestros productos están garantidos contra defectos de fabricación por 90 días, a partir de la compra. Ao constatar un problema protegido por la garantía, póngase en contacto con la tienda donde se adquirió el producto. Ella estará capacitada para atenderlo de la mejor manera de acuerdo con cada caso.

Our products are guaranteed against manufacturing defects for 90 days from the date of purchase. When you find a problem covered by the warranty, please contact the store where the product was purchased. The store be able to serve you in the best way in each case.

Exclusões

- Desgaste natural ou danos causados por água, maresia, ferrugem, incêndio, calor, cupins e pragas em geral.
- Montagem, manutenção e uso inadequado.
- Não cumprimento das recomendações técnicas do esquema.
- Montagens e desmontagens após a primeira instalação.
- Instalações elétricas e outras afins.

Exclusiones

- *Desgaste natural o daños causados por agua, mares, maresia, incendios, calor, termitas y plagas en general.*
- *Montaje, mantenimiento y uso inadecuado.*
- *No cumplimiento de las recomendaciones técnicas del esquema.*

Exclusions

- *Natural wear or damage caused by water, sea, rust, fire, heat, termites and plagues in general.*
- *Assembly, maintenance and improper use.*
- *Failure to comply with the technical recommendations of the assembly instructions.*

Importante

A Linea Brasil não autoriza nenhuma pessoa, loja ou entidade assumir em seu nome qualquer outra garantia que não conste no certificado. O fabricante reserva-se no direito de efetuar nos produtos eventuais modificações que considerar necessárias, sem prejudicar as características essenciais. Os produtos terão peças de assistência para reposição no período de 1 ano a contar de sua retirada do mercado, desde que haja matéria-prima equivalente, observando o dispositivo no Art.32 da Lei 8.078/90 (Cód. Defesa do Consumidor). O atendimento para produtos fora de linha é feito por programação especial, através da loja revendedora sob aprovação de consulta prévia ao fabricante.

Importante

Linea Brasil no autoriza a ninguna persona, tienda o entidad a asumir en su nombre cualquier otra garantía que no figure en el certificado. El fabricante se reserva el derecho de efectuar en los productos eventuales modificaciones que considere necesarias, sin perjudicar las características esenciales. Los productos tendrán piezas de asistencia para reposición en el período de 1 año a partir de su retirada del mercado. La atención para productos fuera de línea es hecha por programación especial, a través de la tienda revendedora bajo aprobación de consulta previa al fabricante.

Important

Linea Brasil does not authorize any person, store or entity to assume on its behalf any other warranty that does not appear on the certificate. The manufacturer reserves the right to make in the products any modifications that it considers necessary without prejudice to the essential characteristics. The products will have replacement parts within one year of being withdrawn from the market. The service for off-line products is done by special programming, through the store reseller under prior consultation with the manufacturer.

INSTRUÇÕES DE LIMPEZA E CONSERVAÇÃO

INSTRUCCIONES PARA LA LIMPIEZA E CONSERVACION / CLEAN AND PRESERVATION INSTRUCTURE

Para retirar o pó, utilize um pano seco, espanador ou aspirador. Se necessário, para uma limpeza mais efetiva, utilize um pano levemente umedecido com água. Finalize com uma flanela limpa e seca.

Para eliminar el polvo, utilice un paño seco, mopa o la aspiradora. Si es necesario, para una limpieza más eficaz, utilice un paño ligeramente humedecido con agua. Terminar con un paño limpio y seco.

To take dirty, use a dry cloth, duster or vacuum. If necessary to take the dust, use a wet cloth. Finish with a clean and dry flannel.

IMPORTANTE / IMPORTANTE / IMPORTANT

 Não utilize produtos abrasivos como álcool e detergentes, como também esponjas rígidas ou palha de aço na limpeza dos móveis. *No use limpiadores abrasivos como alcohol y detergentes, así como esponjas rígidas o lana de acero para limpiar los muebles. Do not use abrasives such as alcohol and detergent, tough soaker also steel wool to clean the furniture.*

 Proteja a superfície do móvel de objetos que transmitam calor ou umidade. *Proteja la superficie del mueble de objetos que transmitan calor o humedad. Protect the surface of the furniture against objects that can pass heat and humidity.*

 Evitar o contato de água e produto de limpeza com o rodapé do produto, pois poderá danificá-lo. *Evitar el contacto con agua y producto de limpieza con el rodapé del producto, pues podrá dañarlo. Avoid the contact of water and cleaning products with baseboard, cause it should damage your product.*

 Procure sempre utilizar flanela limpa e seca para a limpeza. *Busque siempre utilizar flanela limpia y seca para la limpieza. Try always to use a clean and dry flannel to cleaning.*

 Cuidado com objetos pontiagudos, eles podem arranhar a superfície das portas e tampo. *Cuidado con objetos afilados, ellos pueden rayar la superficie de las puertas e la tapa. Take care with sharp objects, they can scratch the door lid surface.*

Imagem Ilustrativa/ Illustrative Image/ Imagen Ilustrativa



Preste Atenção! ¡Preste atención! Attention!

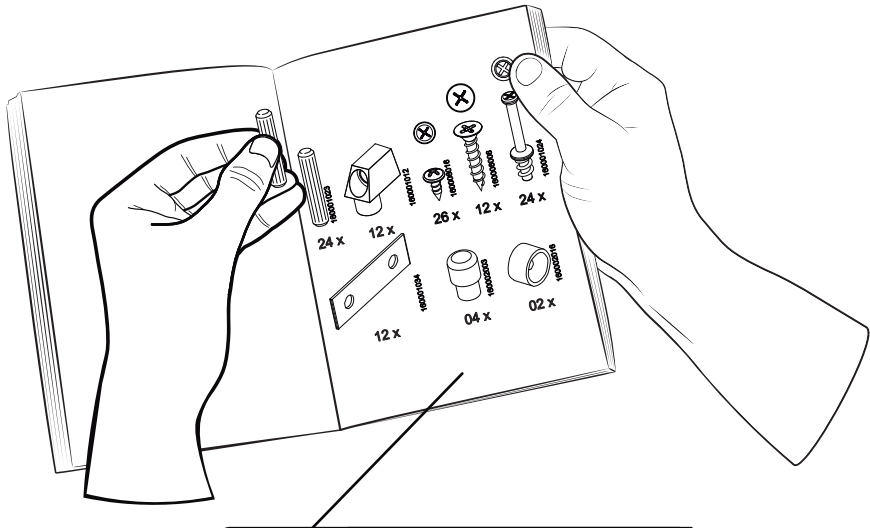

As ferragens dos nossos manuais são sempre apresentadas nas mesmas proporções da peça na vida real.
Caso apareça alguma dúvida no decorrer do processo de montagem, coloque a ferragem ao lado do desenho e faça a consulta :D

Los accesorios de nuestros manuales siempre se presentan en las mismas proporciones que la pieza en la vida real.
Si tiene alguna duda durante el proceso de montaje, coloque los accesorios junto al dibujo y haga una consulta :D

The accessories in our manuals are always presented in the same proportions as the spare part in real life.
If you have any questions during the assembly process, place the accessory next to the drawing and make an inquiry :D

Símbolos: Símbolos: Symbols:



- + Parafuso Phillips
- Parafuso Fenda
- Parafuso Allen

- + Tomillo Phillips
- Tomillo Ranurado
- Tomillo Allen

- + Phillips screw
- Slotted Screw
- Allenscrew

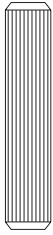

160001023

16x

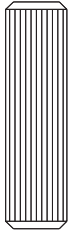

160001004

02x



160001003

02x

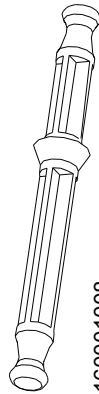

160001008

02x

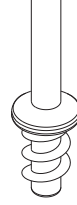

160001024

16x

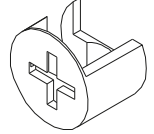

160001025

20x



160001022

08 x

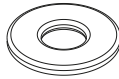

160001009

14x

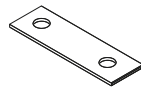

160001034

24x



160002012

02x

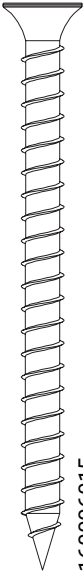

160006015

13x



160006010

12x

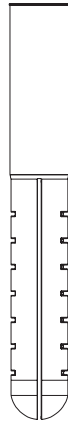

160002006

13x



160006008

55x



160006016

61x

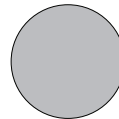

160002002

12x



160002015

02x



160006020

04x



160006019

04x



160006001

02x

1:1

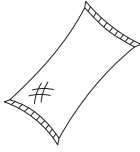

02x

160001001



02x

160002005

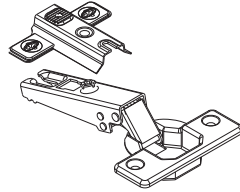

02x

160003002

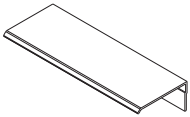

01x

160005053

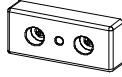

03x

160002014

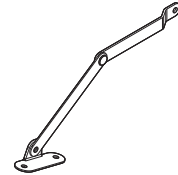

01 x

160001033

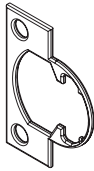

02x

160003006

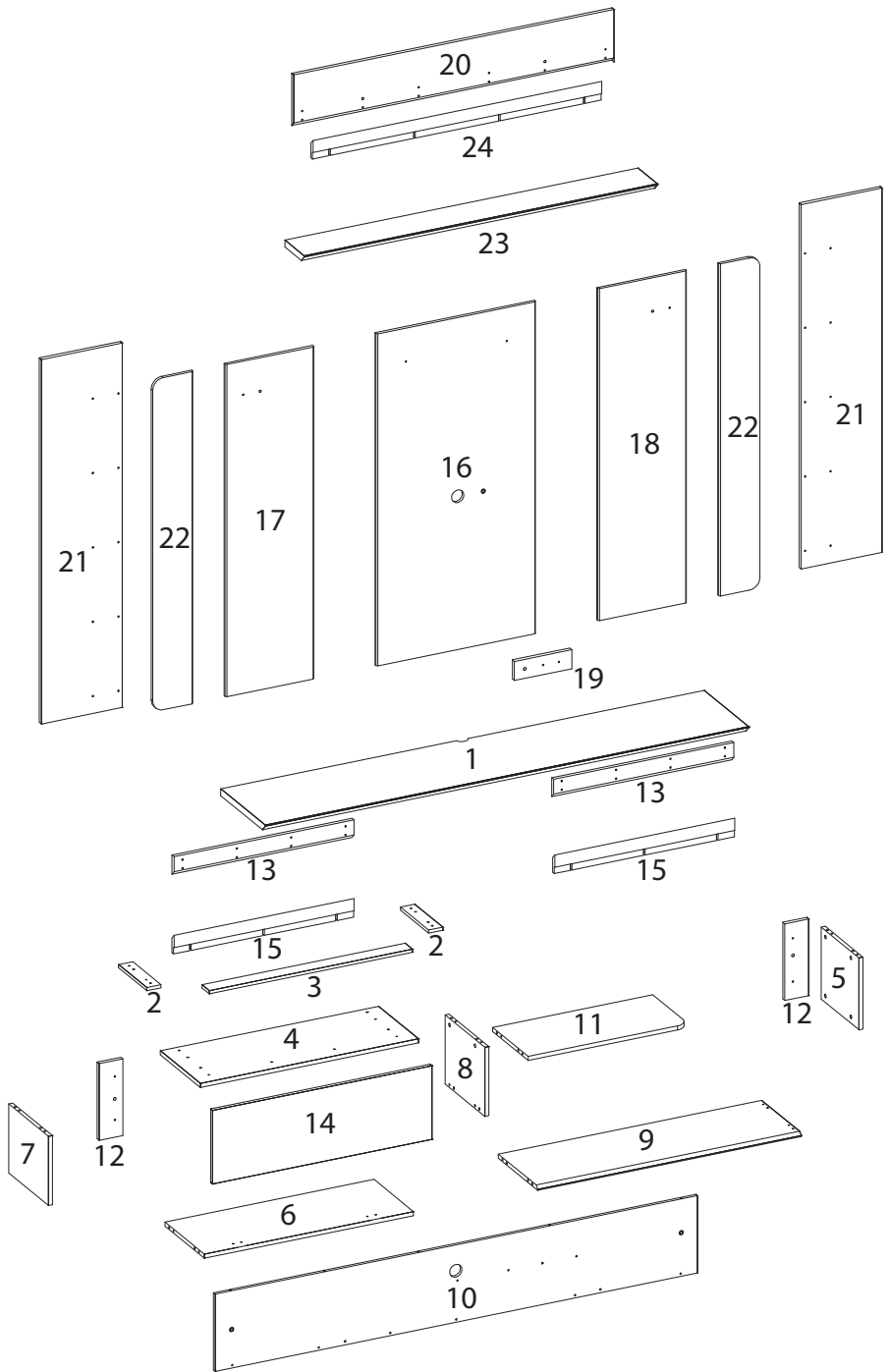

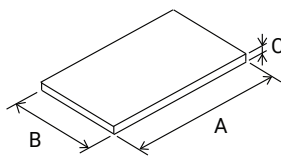

VOLUME	ITEM	PEÇA	DESCRIÇÃO	DIMENSÕES (mm)			QUANTIDADE	Material
				Dimensão/Dimension				
				A	B	C		
Caja	Artículo	Pieza	Descripción				Cantidad	
BOX	Item	Part	Description				Amount	
1	1	510430001	TAMPO SUPERIOR	1820	334	25	1	MDP
1	2	510430002	ENGROSSO LATERAL	212	54	12	2	MDP
1	3	510430003	ENGROSSO FRONTAL	766	54	12	1	MDP
2	4	510430004	TAMPO INFERIOR	822	301	12	1	MDP
1	5	510430005	LATERAL DIREITA	284	221	15	1	MDP
2	6	510430006	BASE ESQUERDA	794	297	12	1	MDP
1	7	510430007	LATERAL ESQUERDA	299	211	12	1	MDP
1	8	510430008	DIVISAO CENTRAL	299	211	12	1	MDP
2	9	510430009	BASE DIREITA	992	297	12	1	MDP
1	10	510430010	PAINEL TRASEIRO NICH	1816	237	12	1	MDP
2	11	510430011	PRATELEIRA NICH	602	267	15	1	MDP
1	12	510430012	TRAVA PAINEL	235	70	15	2	MDP
1	13	510430013	TRAVESSA PAINEL NICH	675	70	15	2	MDP
2	14	510430014	PORTA	826	224	15	1	MDP
1	15	510430015	TRAVESSA PAREDE NICH	675	70	12	2	MDP
2	16	510430016	PAINEL TV MAIOR	1120	602	12	1	MDP
2	17	510430017	PAINEL TV MEDIO ESQUERDO	1120	334	12	1	MDP
2	18	510430018	PAINEL TV MEDIO DIREITO	1120	334	12	1	MDP
1	19	510430019	APOIO PAINEL	160	70	15	1	MDP
1	20	510430020	PAINEL HORIZONTAL	1416	193	15	1	MDP
1	21	510430021	PAINEL VERTICAL	1239	200	15	2	MDP
2	22	510430022	PAINEL TV MENOR	1120	153	12	2	MDP
1	23	510430023	PRATELEIRA	1330	146	25	1	MDP
2	24	510430024	TRAVESSA PAREDE PAINEL	1330	146	15	1	MDP

ITEM	DESCRIPTION
1	TOP TOP
2	SIDE THICKENING
3	FRONT THICKNESS
4	LOWER TOP
5	RIGHT SIDE
6	LEFT BASE
7	LEFT SIDE
8	CENTRAL DIVISION
9	RIGHT BASE
10	NICHE REAR PANEL
11	NICHE SHELF
12	PANEL LOCK
13	NICHE PANEL TRAY
14	DOOR
15	NICHE WALL TRAY
16	BIGGER TV PANEL
17	MEDIUM LEFT TV PANEL
18	MIDDLE RIGHT TV PANEL
19	PANEL SUPPORT
20	HORIZONTAL PANEL
21	VERTICAL PANEL
22	SMALLER TV PANEL
23	SHELF
24	PANEL WALL TRAY

ARTÍCULO	DESCRIPCIÓN
1	ARRIBA ARRIBA
2	ESPESOR LATERAL
3	ESPESOR DELANTERO
4	SUPERIOR INFERIOR
5	LADO DERECHO
6	BASE IZQUIERDA
7	LADO IZQUIERDO
8	DIVISIÓN CENTRAL
9	BASE DERECHA
10	PANEL TRASERO DE NICH
11	ESTANTE NICH
12	BLOQUEO DEL PANEL
13	BANDEJA DE PANEL DE NICH
14	PUERTA
15	BANDEJA DE PARED NICH
16	PANEL DE TV MÁS GRANDE
17	PANEL TV MEDIANO IZQUIERDO
18	PANEL DE TV DEL MEDIO DERECHO
19	SOPORTE DE PANELES
20	PANEL HORIZONTALES
21	PANELES VERTICALES
22	PANEL DE TV MÁS PEQUEÑO
23	ESTANTE
24	BANDEJA DE PARED

01

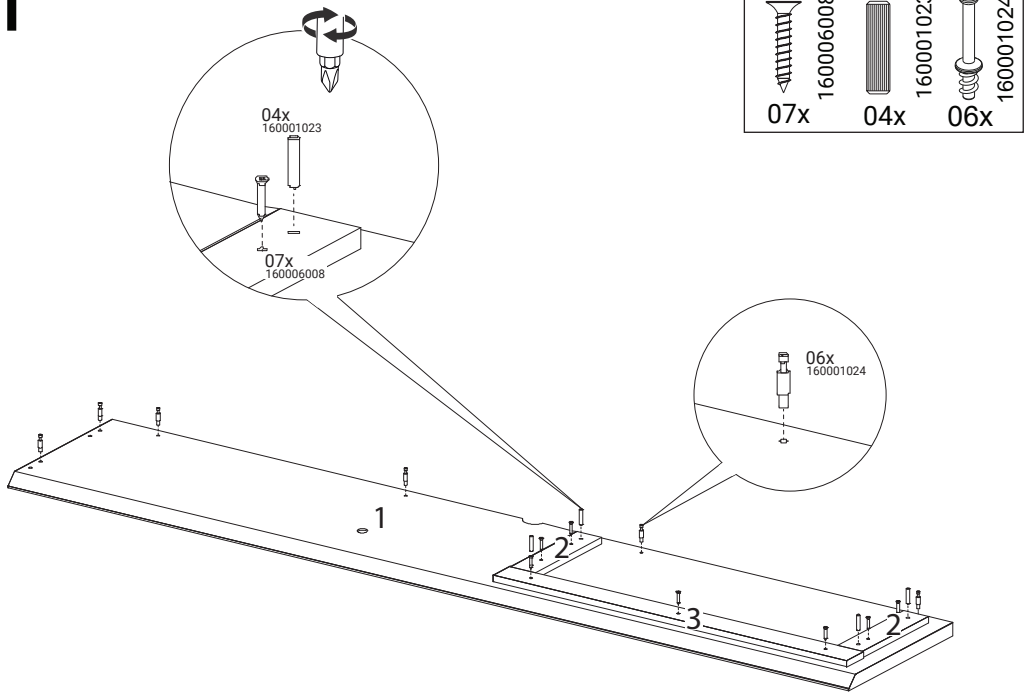

02

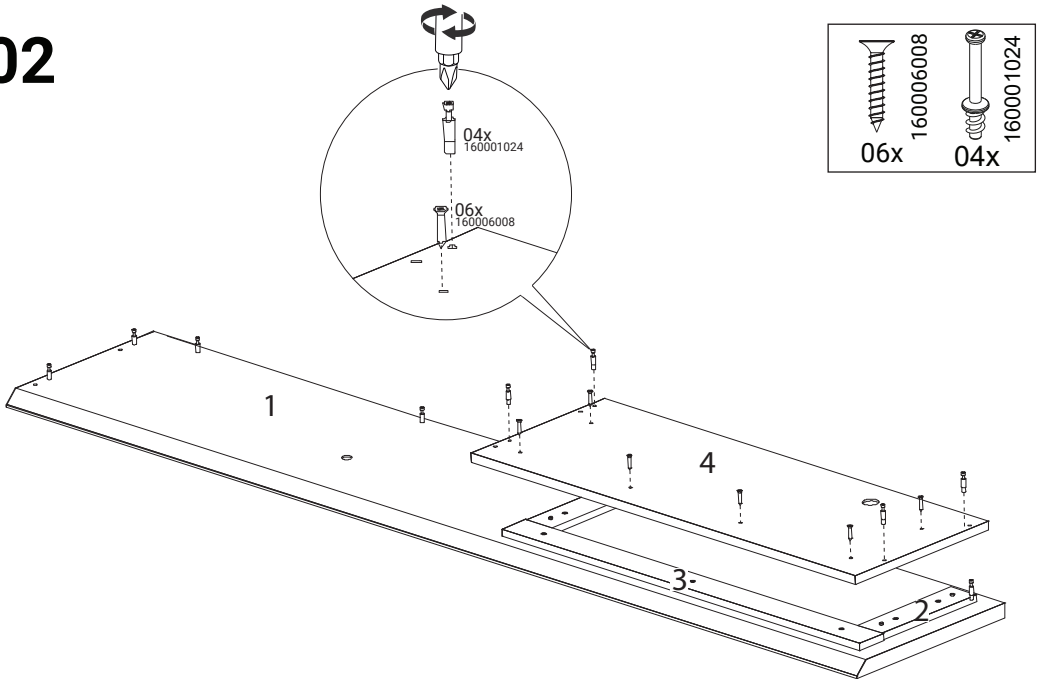

03

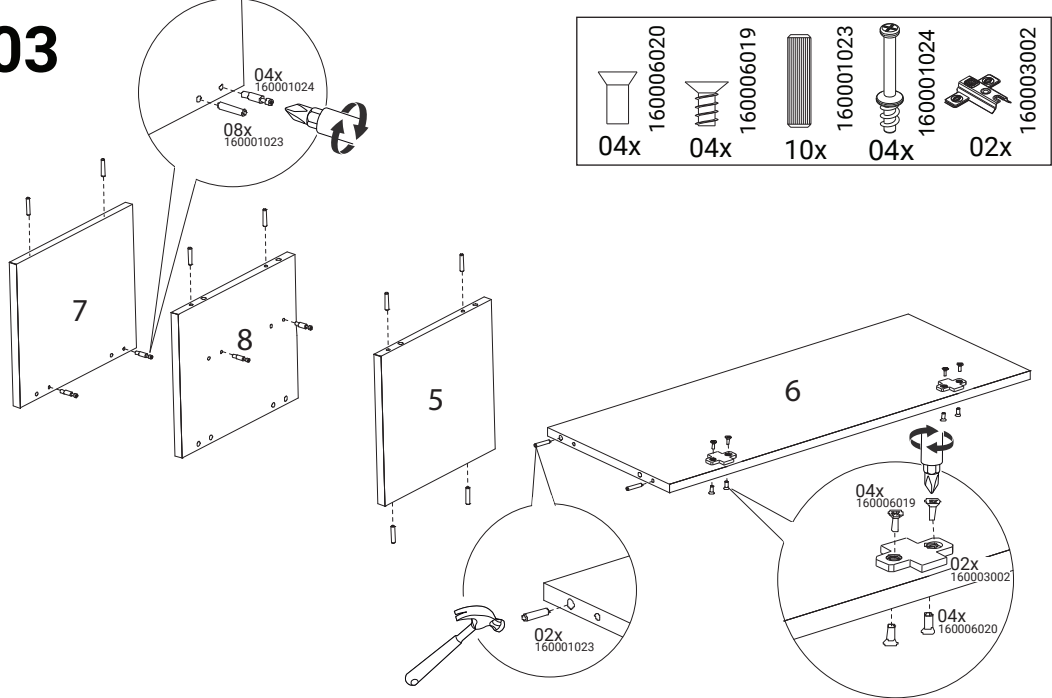

04

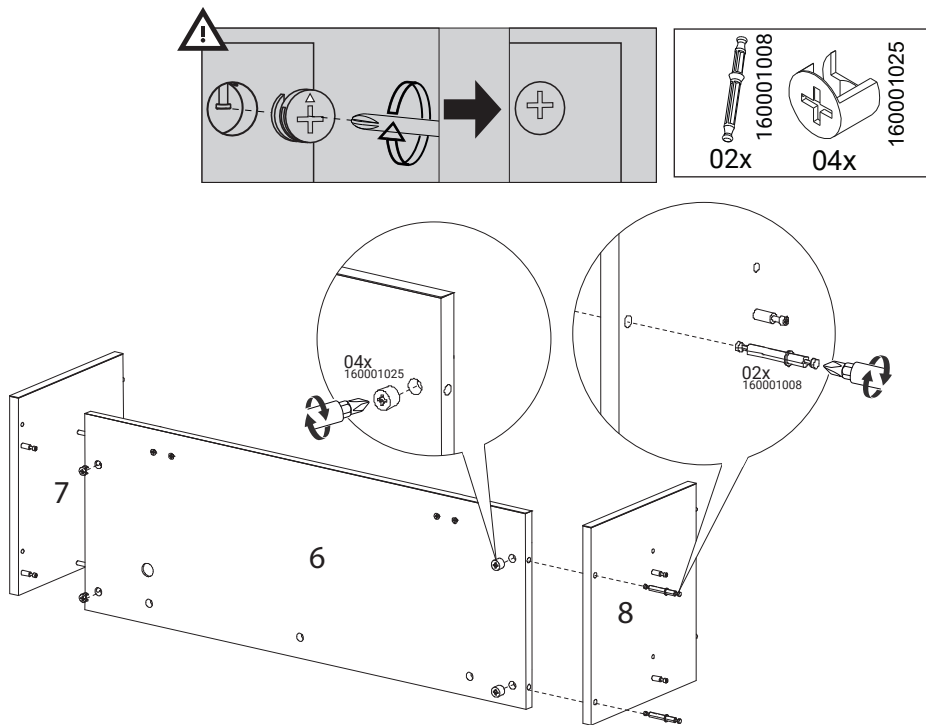

05

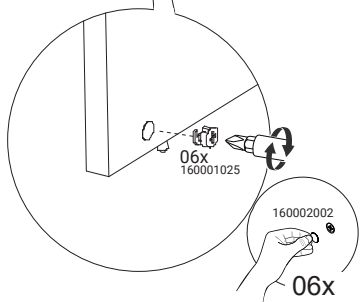
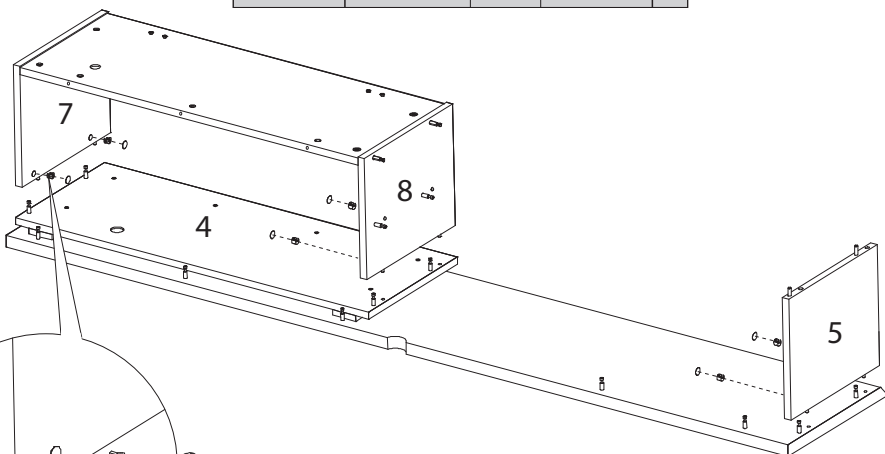
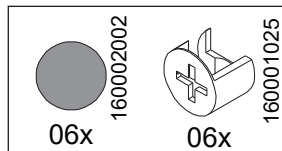
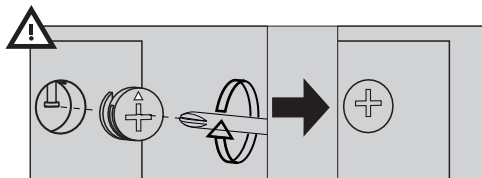

06

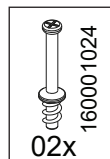
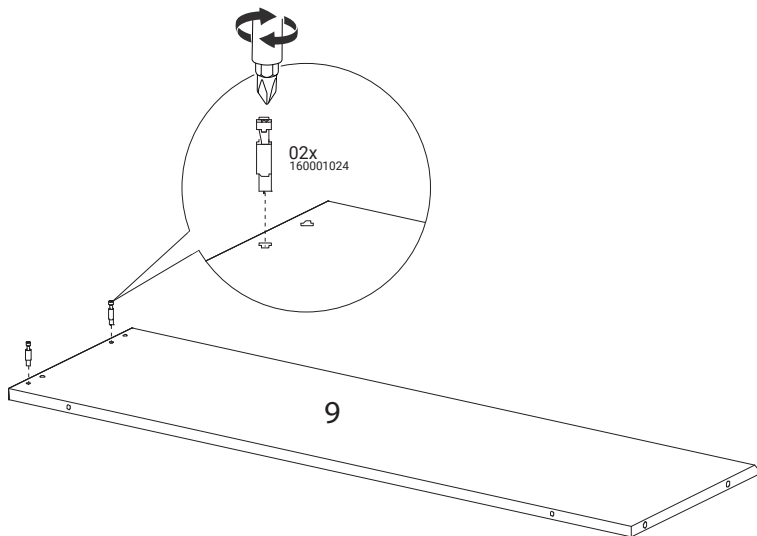

07

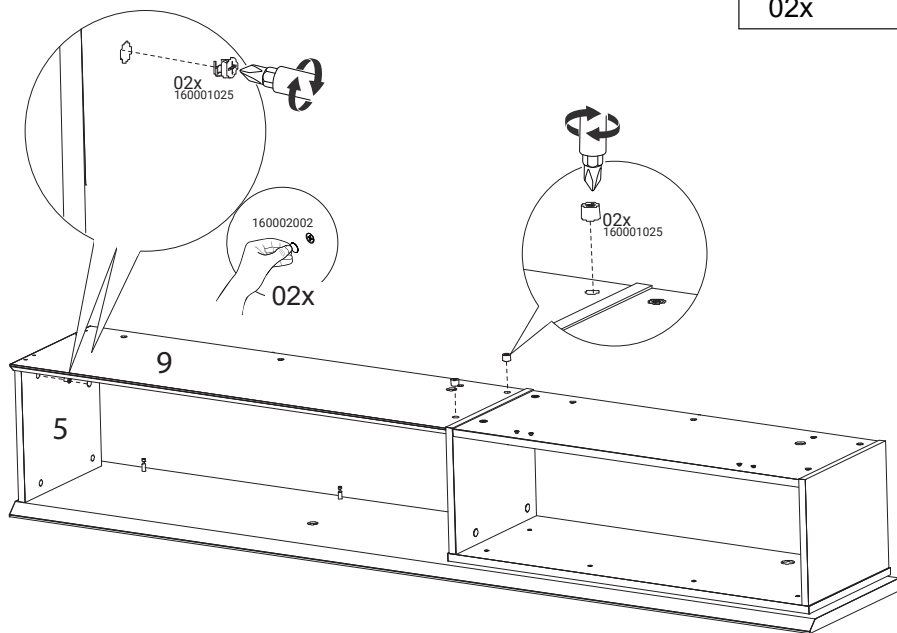
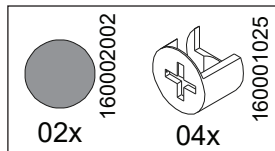

08

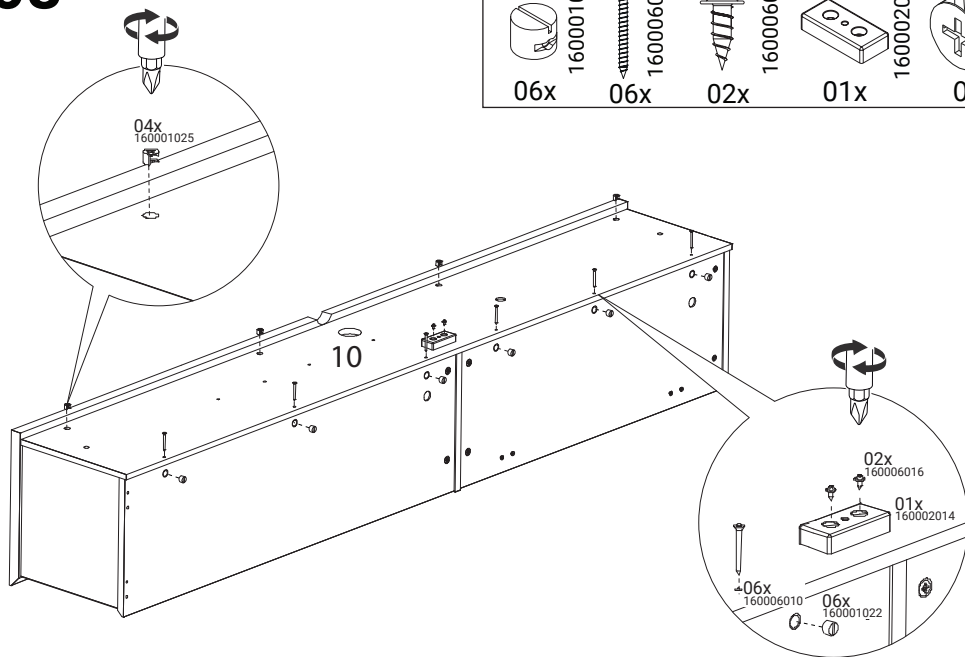
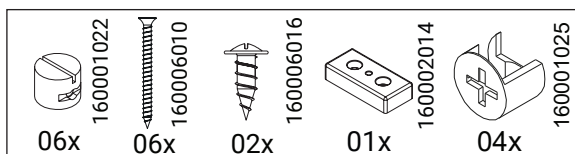

09

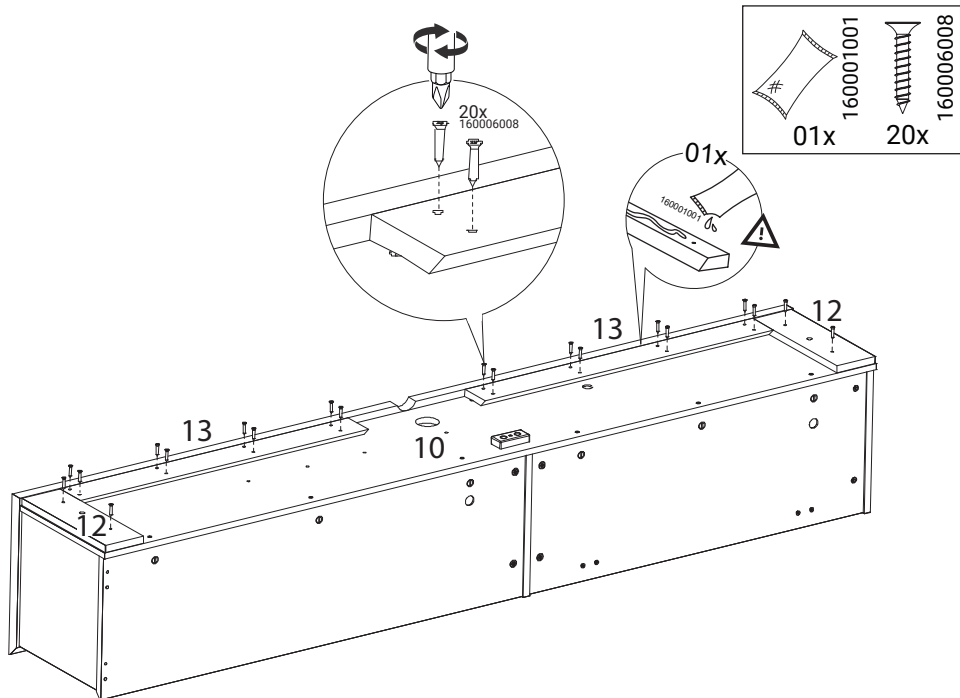



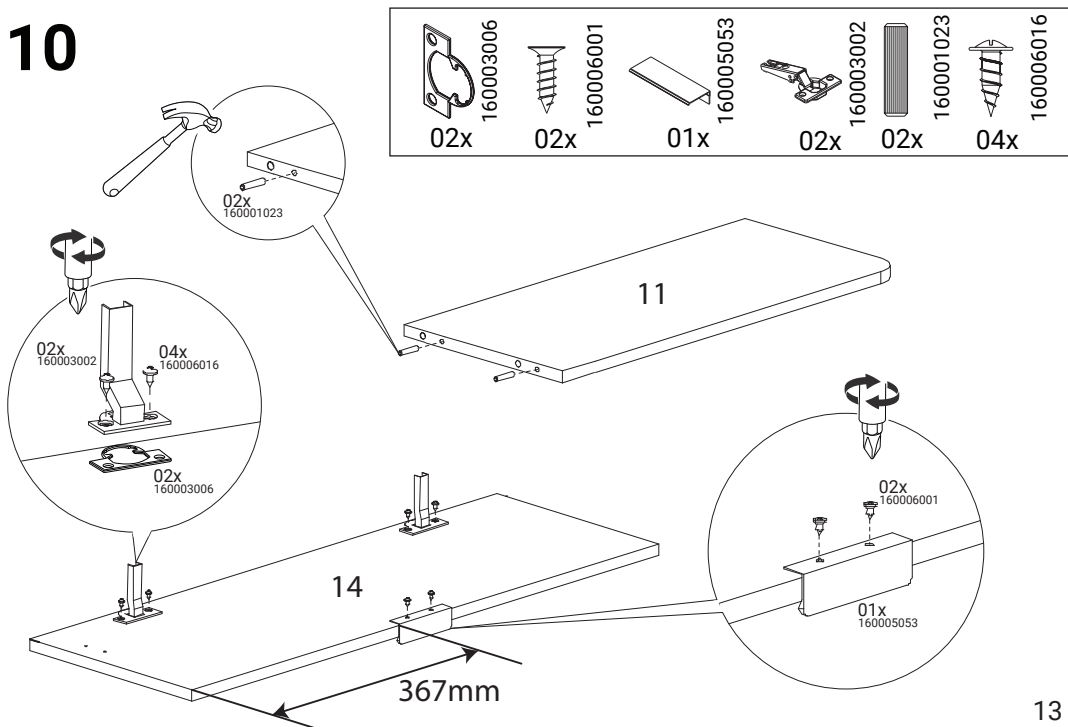



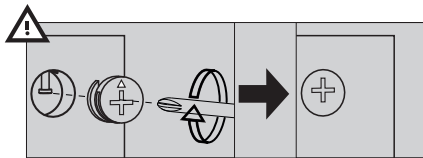

10



11

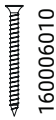

- | | | | |
|---|---|---|--|
| 
01x
160001009 | 
02x
160001025 | 
02x
160002015 | 
01x
160002005 |
| 
03x
160006016 | 
02x
160001022 | 
02x
160006010 | 
01x
160001033 |

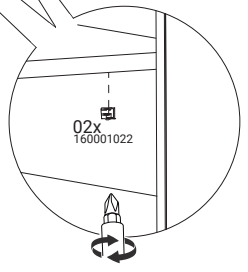
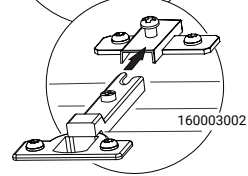
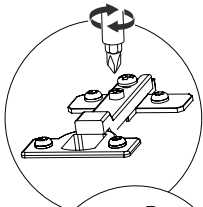
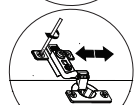
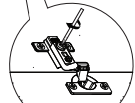
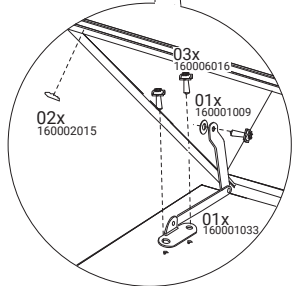
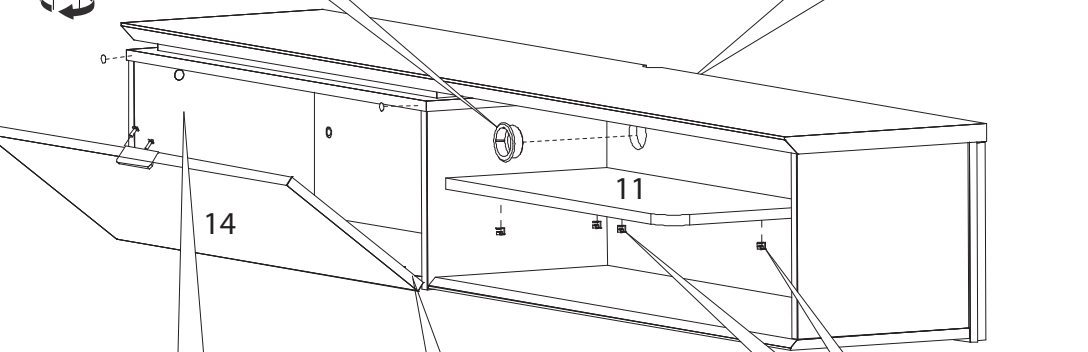
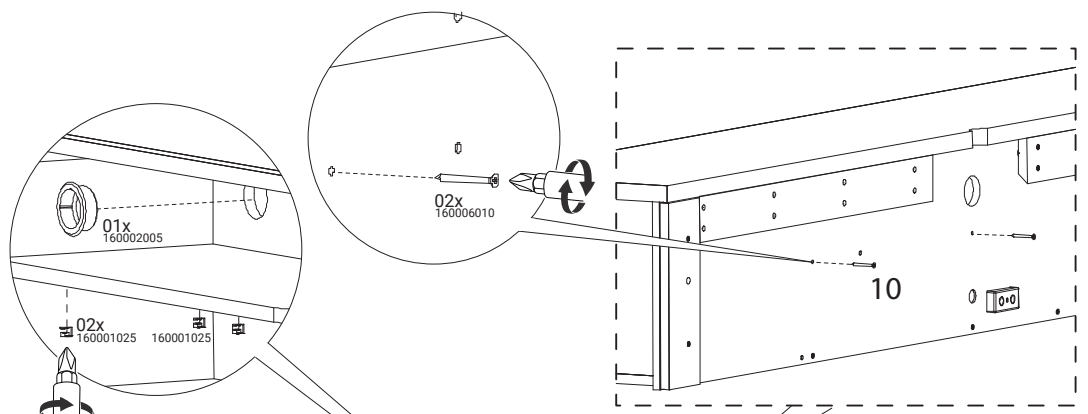

12

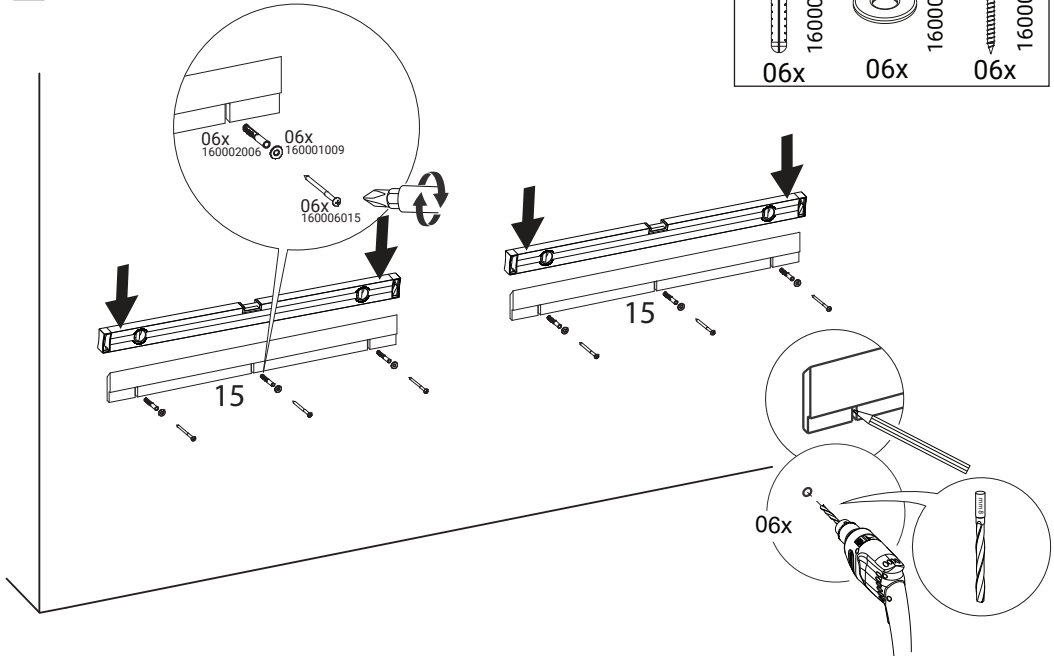

13

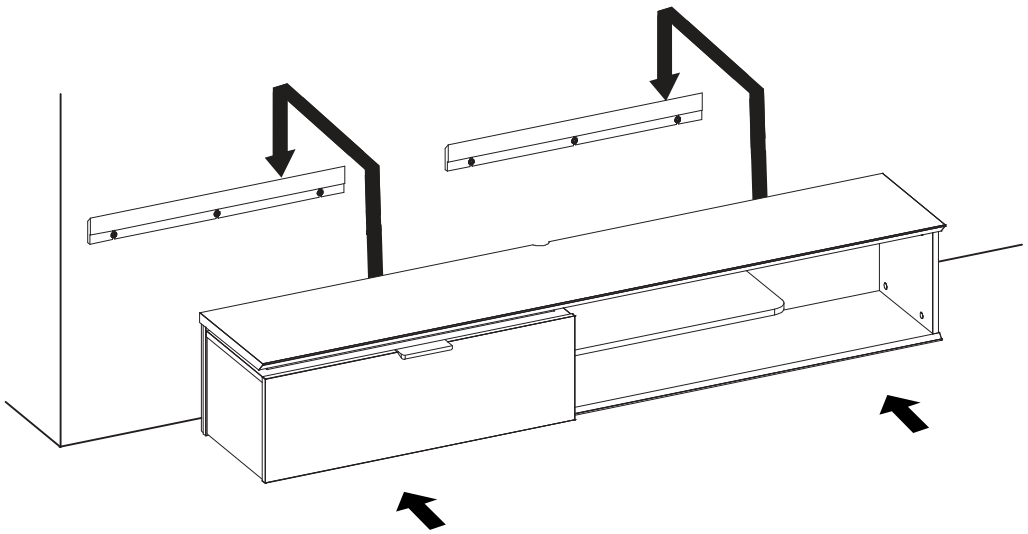

14

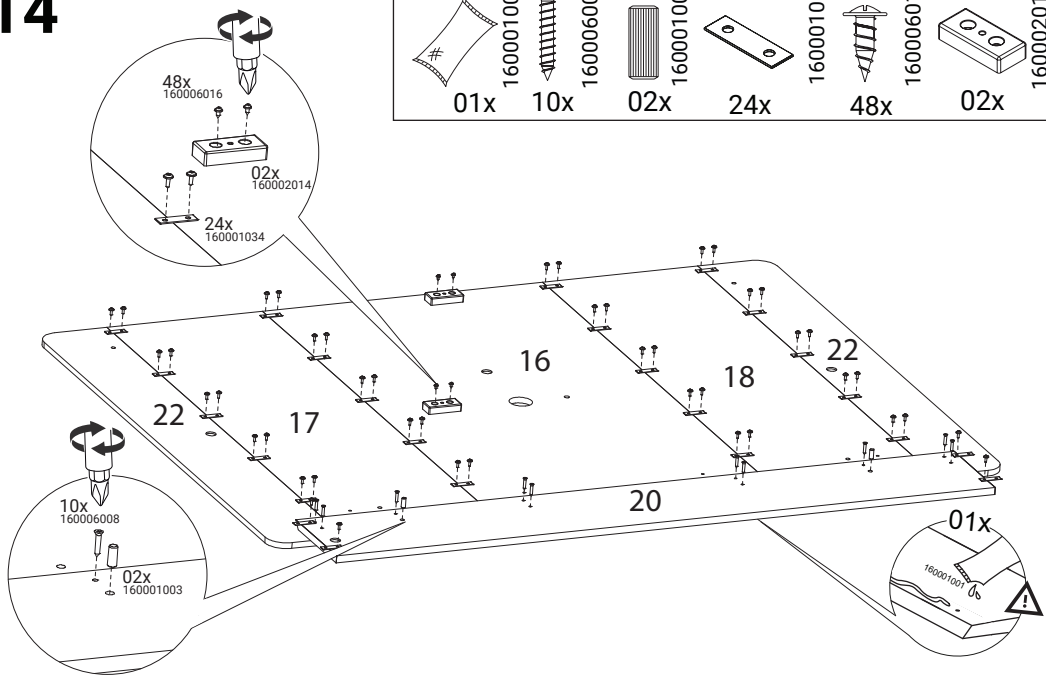
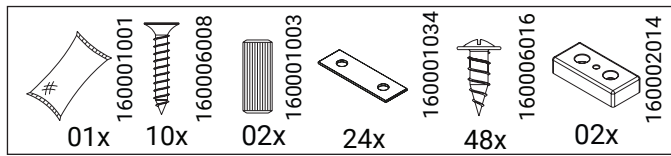

15

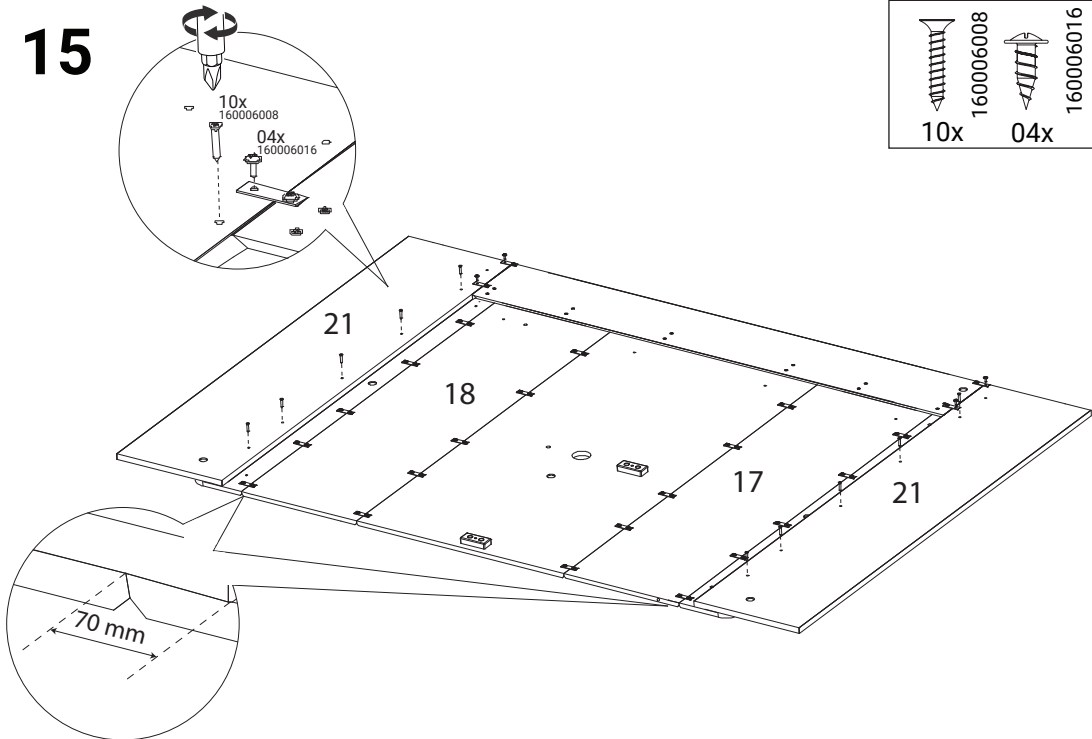
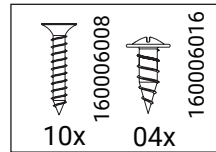

16

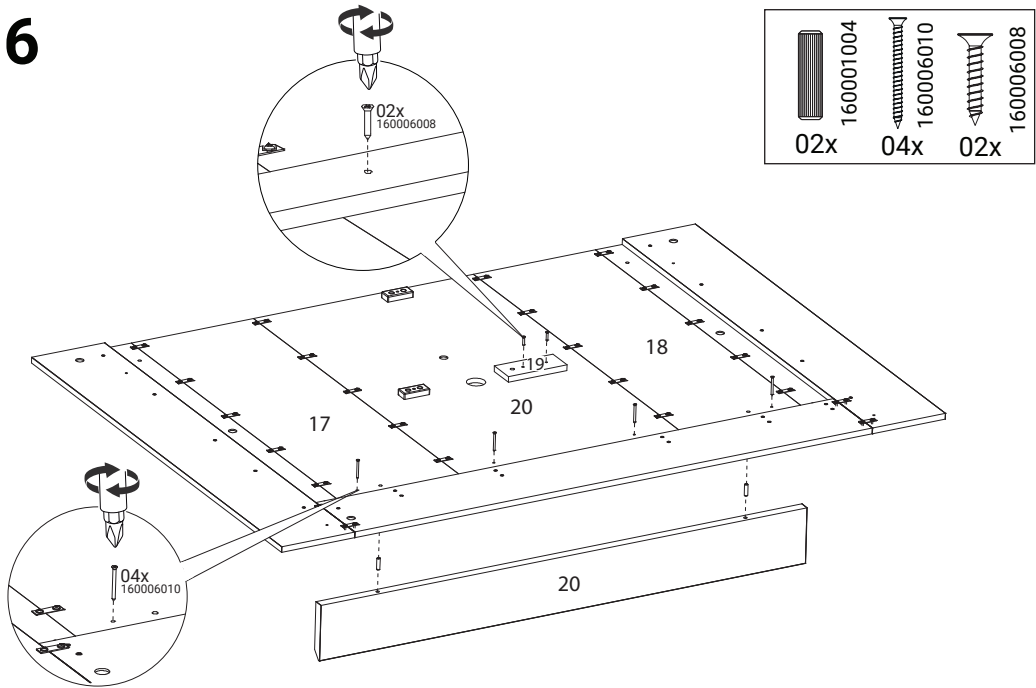

17

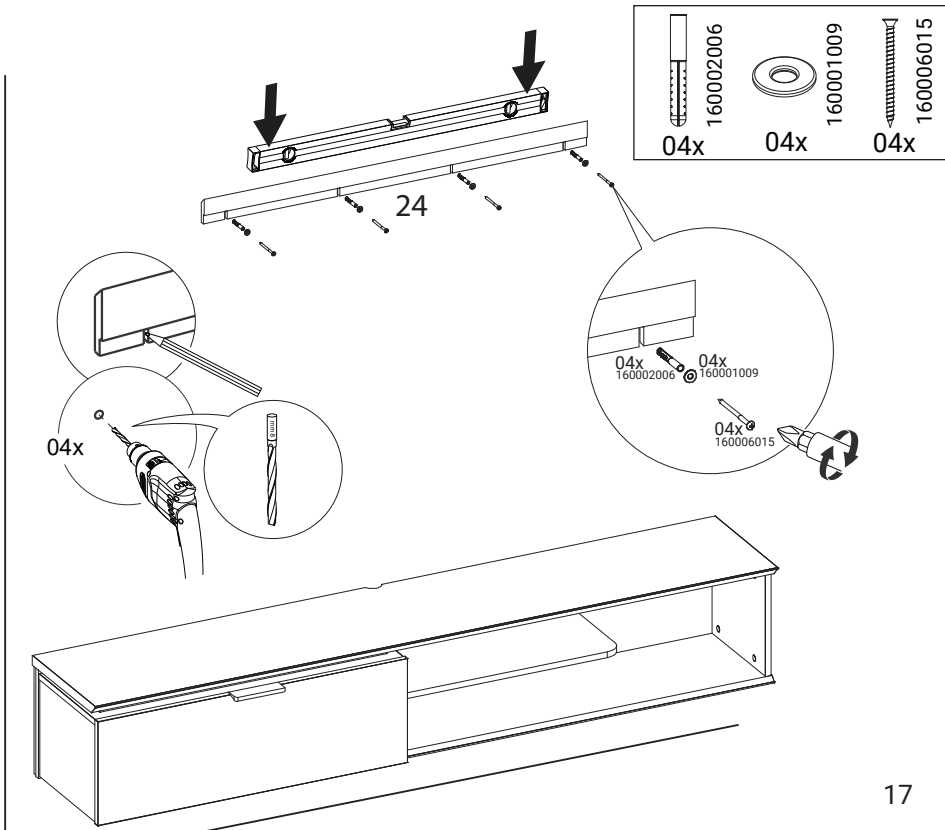

18

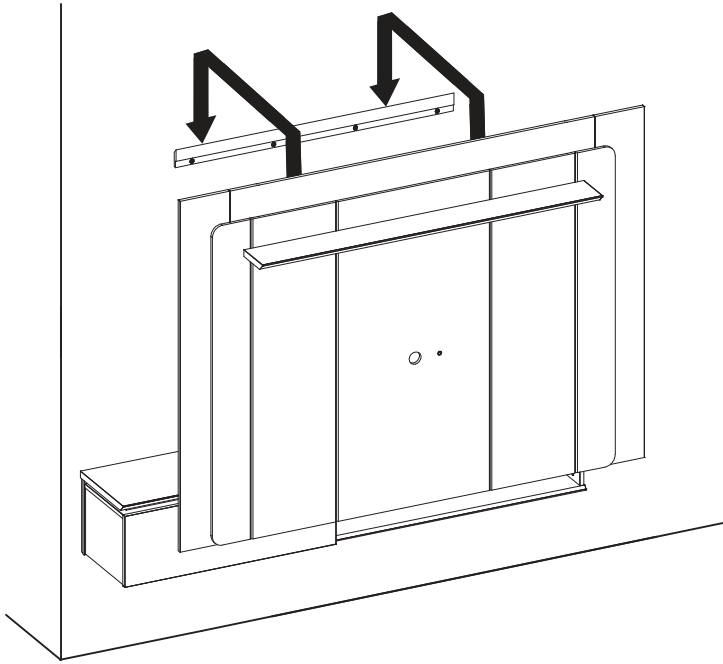

19

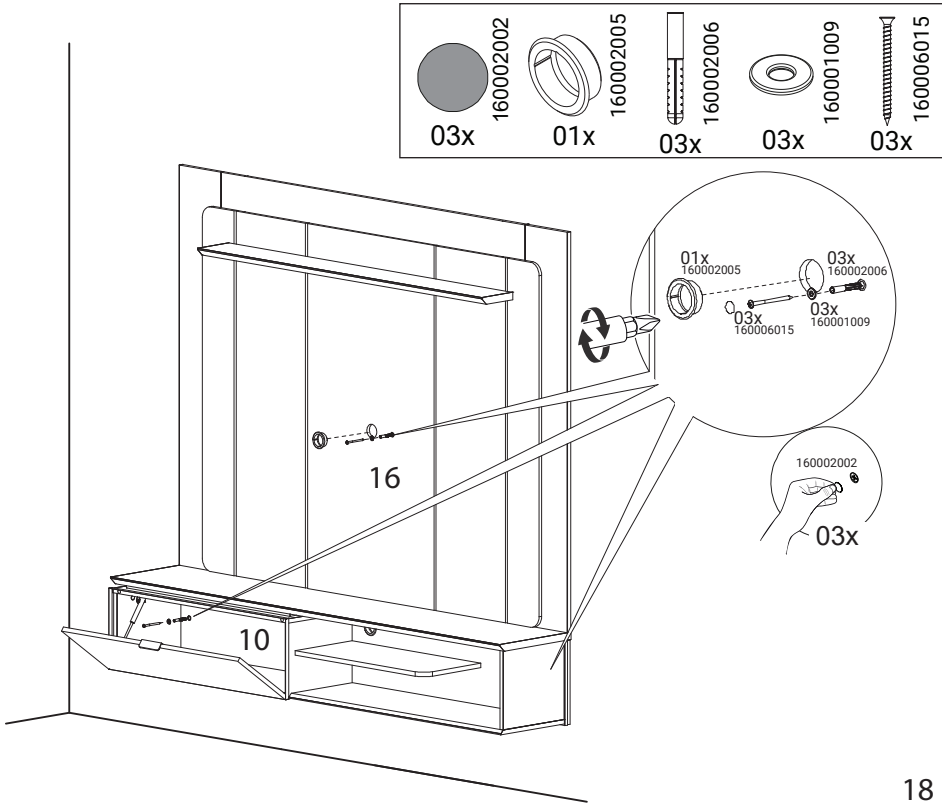

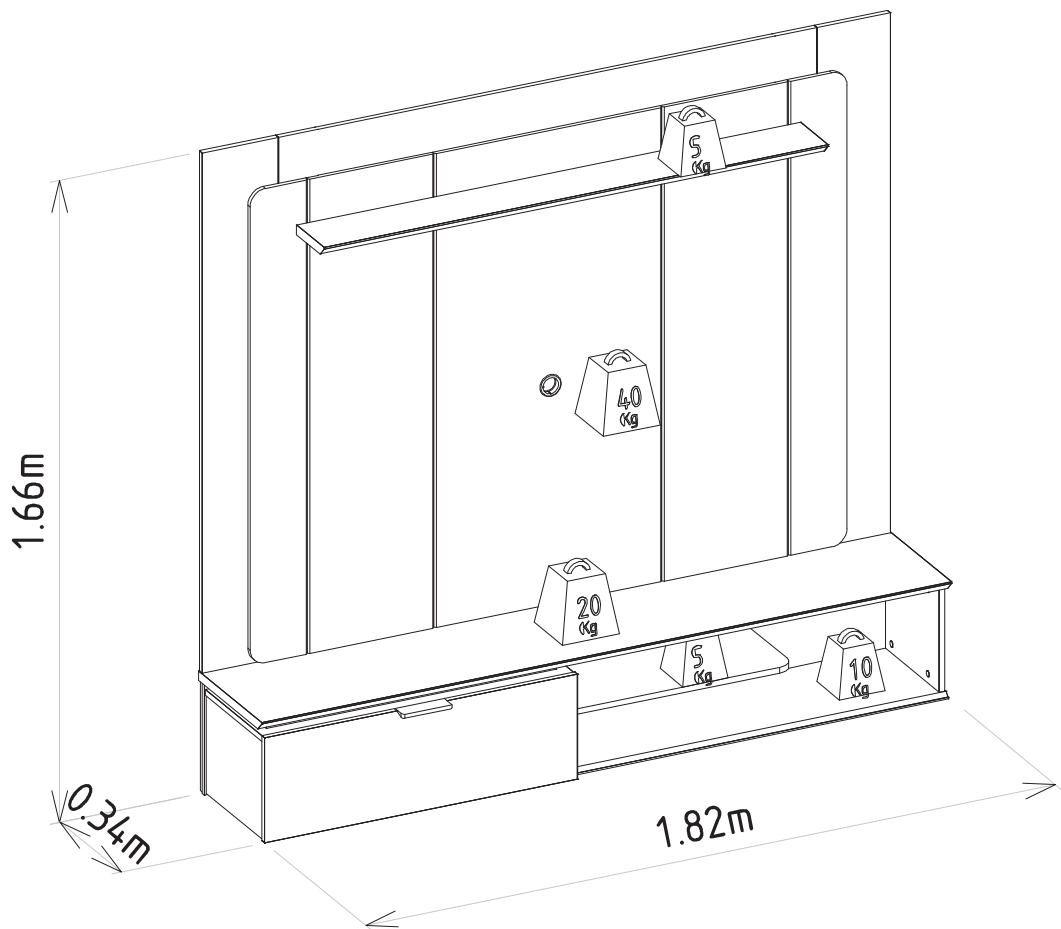

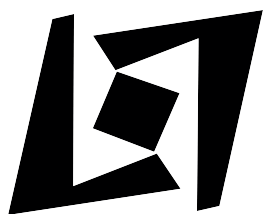

Linea Brasil