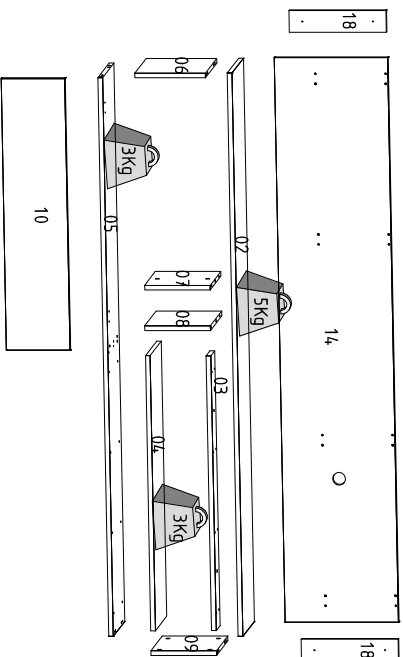
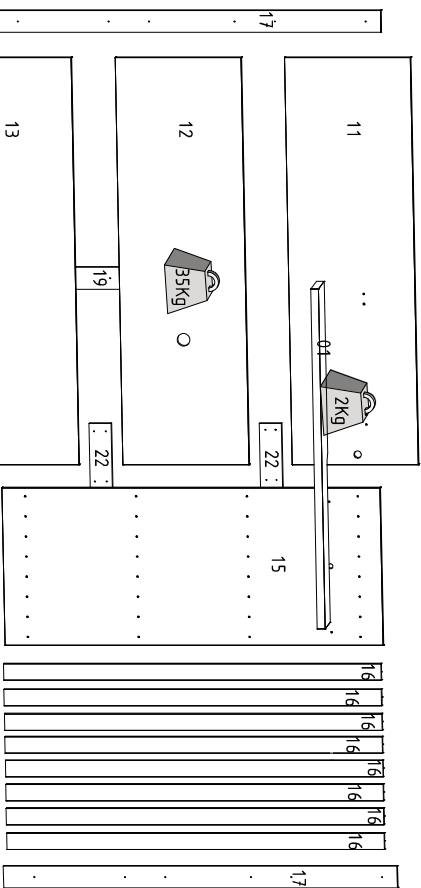

20

21

Cuidados com a limpeza do móvel:

Não molhar o móvel e não expor em lugar úmido.

Do not wet the furniture and do not expose it in a humid place.

No moje los muebles y no los esponga en un lugar húmedo.

Não expor o móvel próximo de fontes de calor.

Do not expose this furniture close to sources of heat.

No exponga el mueble cerca a fuentes de calor.

Limpar apenas com pano limpo e levemente úmido

Clean the product using only a clean and slightly damp cloth.

Limpiar solo con un paño limpio y ligeramente húmedo

Cód.	Referência	Off/Nogueira	Cor	Pecas	Qt.	Medidas	M. p.	Piece	Pieza
01	1635A0.001	440	690	Prateleira superior	1	1084x150x25	MDP	Top shelf	Estante superior
02	1635A0.002	690	440	Tampo	1	1796x298x15	MDP	Cover	Cubierta
03	1635A0.003	440	440	Apoio	1	876x100x15	MDP	Support	Apoio
04	1635A0.004	440	690	Prateleira inferior	1	877x295x15	MDP	Bottom shelf	Estante inferior
05	1635A0.005	690	690	Base	1	1780x296x15	MDP	Base	Base
06	1635A0.006	690	690	Lateral esquerda	1	297x224x15	MDP	Left side	Lado izquierdo
07	1635A0.007	690	690	Batente	1	278x208x15	MDP	Flap	Solapa
08	1635A0.008	440	440	Divisão	1	296x208x15	MDP	Division	División
09	1635A0.009	440	690	Lateral direita	1	296x208x15	MDP	Right side	Lado derecha
10	1635A0.010	690	690	Porta	1	866x202x15	MDP	Door	Puerta
11	1635A0.011	690	690	Panel superior	1	1298x400x15	MDP	Top panel	Panel superior
12	1635A0.012	690	690	Panel superior cen	1	1298x400x15	MDP	Top center panel	Panel central superior
13	1635A0.013	690	690	Panel inferior cen	1	1298x400x15	MDP	Lower center panel	Panel central inferior
14	1635A0.014	693	690	Panel inferior	1	1800x360x15	MDP	Bottom panel	Panel inferior
15	1635A0.015	690	690	Panel lateral	1	1200x502x15	MDP	Side panel	Panel lateral
16	1635A0.016	440	440	Aplicque	8	1198x52x15	MDP	Apply	Aplicar
17	1635A0.017	690	2	Travessa superior lat	2	1250x70x15	MDP	Side upper crosspiece	Travessaio superior lateral
18	1635A0.018	690	2	Travessa inferior lat	2	308x70x15	MDP	Bottom side crosspiece	Travessaio inferior lateral
19	1635A0.019	99	1	Travessa central mai	1	600x70x15	MDP	Larger center	Travessaio central más grande
20	1635A0.020	99	1	Travessa fixação sup	1	1600x80x15	MDP	Travessa fixation sup	Travessaio fijación superior
21	1635A0.021	99	1	Travessa fixação inf	1	1090x80x15	MDP	Travessa fixation inf	Travessaio fijación inferior
22	1635A0.022	99	3	Travessa central men	3	360x70x15	MDP	Smaller central crosspiece	Travessaio central más pequeño
23	1635A0.023	99	2	Travessa fixação sup men	2	540x80x15	MDP	Travessa fixation sup men	Travessaio fijación sup men
24	1635A0.024	99	2	Travessa fixação inf men	2	540x80x15	MDP	Travessa fixation inf men	Travessaio fijación inf men

A	B	C	D	E	F	G	H
Parafuso 3,5x14 cod. 776	Parafuso 4,0x25 cod. 780	Parafuso 4,0x40 cod. 781	Parafuso 4,0x50 cod. 782	Parafuso 5,0x50 cod. 812	Parafuso 5,0x70 cod. 792	Canhota 6x30 cod. 949	Canhota 8x20 cod. 5225
08x	08x	04x	02x	02x	09x	01x	01x
Pino 6/ Girofix cod. 162	Tambor Ø12 cod. 183	Porta cilíndrica cod. 163	Dobr curva 26mm cod. 131	Calço 12mm cod. 136	Chapa rata 2 furos cod. 147	Pivoteador clean cod. 5285	Luminária cod. 954
01x	01x	12x	03x	04x	06x		
Pescas fio 40mm cod. 159	Pescas fio 40mm cod. 307	Burra fixação Ø8 cod. 150	Sacite de cola cod. 160	Tapa furo Off White cod. 307	Tapa furo Nong Real cod. 387		



ETAPAS DA MONTAGEM / STAGES OF THE ASSEMBLY / ETAPAS DE LA ASAMBLEA

Para uma montagem perfeita do produto, siga a sequência:

For a perfect product assembly, follow its sequence / Para un montaje perfecto del producto, sigue la secuencia.

Passo 01
Nesse passo montar produto detizado

A	04x
B	3,5x14
D	01x
E	4,0x50
F	12x
G	6x30
I	02x
J	02x
K	01x
L	02x
M	02x
N	01x
O	Off white

Detalhe porca cilíndrica

Passo 02
Nesse passo montar produto detizado

B	08x
D	4,0x25
E	01x
F	4,0x50
G	04x
K	6x30
L	01x
V	01x
Nogueira	Off white

Passo 03
Nesse passo montar produto detizado

B	08x
H	4,0x25
I	02x
J	8x20
K	04x
L	6x30

Passo 04
Nesse passo montar produto detizado

1º Inserir acessório "1" na peça 02

I	06x
J	06x
L	03x
O	Off white
V	05x
Nogueira	02x
D	4,0x50
E	04x
G	6x30
K	02x

ETAPAS DA MONTAGEM / STAGES OF THE ASSEMBLY / ETAPAS DE LA ASAMBLEA

Para uma montagem perfeita do produto, siga a sequência:

For a perfect product assembly, follow its sequence / Para un montaje perfecto del producto, sigue la secuencia.

Passo 05 Vista traseira

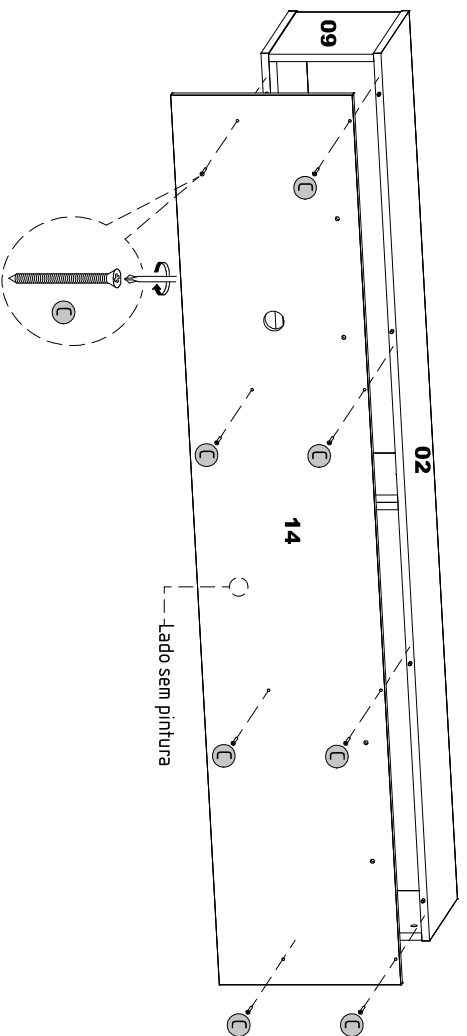
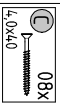

Passo 06 Vista traseira

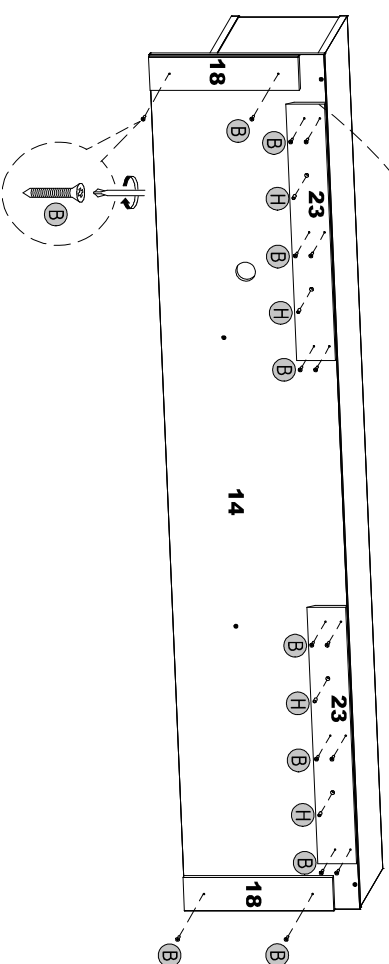
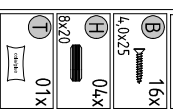

Obs: chanfro para baixo conforme o desenho

ATENÇÃO: USO OBRIGATORIO DE COLA



Passo 07 Vista traseira

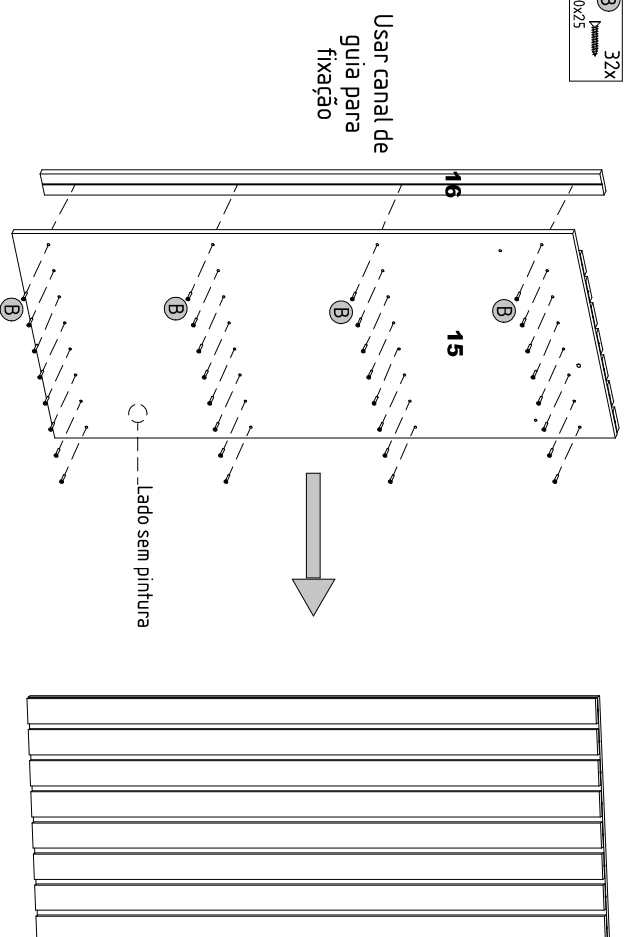
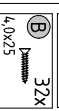

Usar canal de guia para fixação

Vista frontal

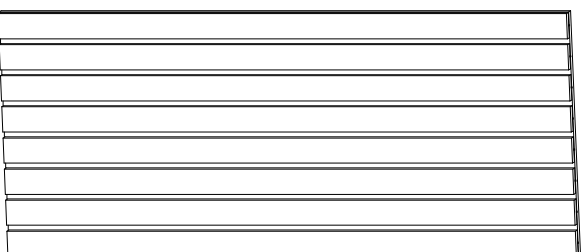

Passo 08 Vista traseira

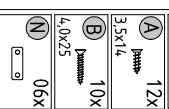

Nesse passo montar produto deitado

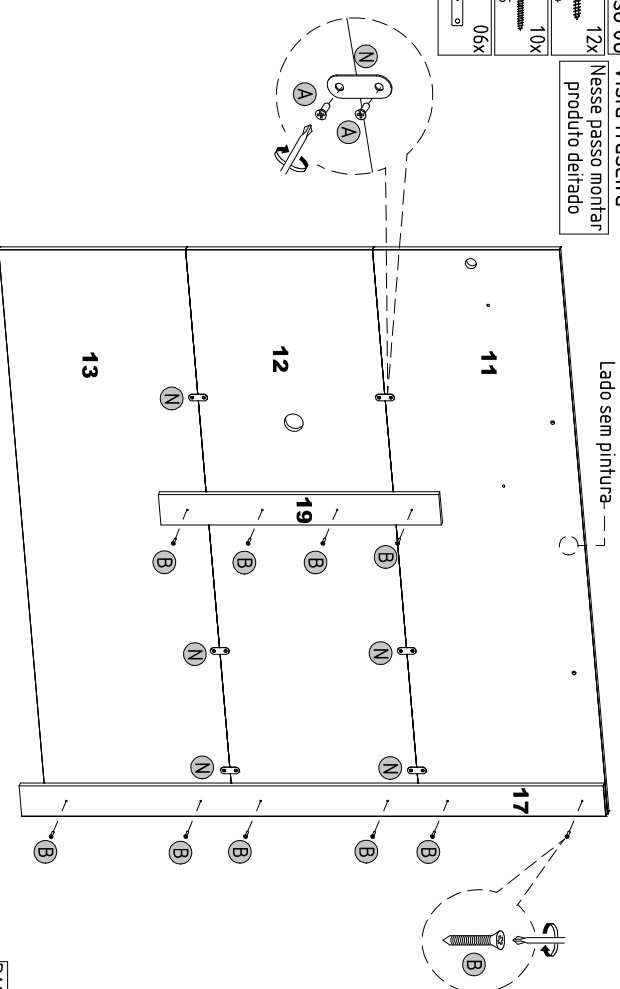

ETAPAS DA MONTAGEM / STAGES OF THE ASSEMBLY / ETAPAS DE LA ASAMBLEA

Para uma montagem perfeita do produto, siga a sequência:

For a perfect product assembly, follow its sequence / Para un montaje perfecto del producto, sigue la secuencia.

Passo 09

A	06x
3.5x14	
B	30x
L.0x25	
N	03x
O	
T	02x
H	03x
8x20	

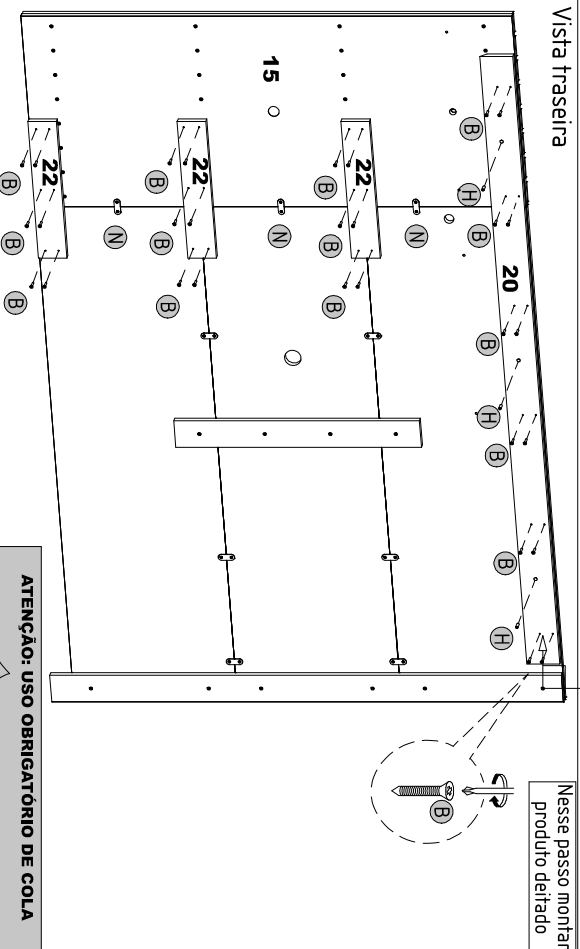

Nesse passo montar produto delatado

ATENÇÃO: USO OBRIGATORIO DE COLA



Passo 11

B	06x
L.0x25	

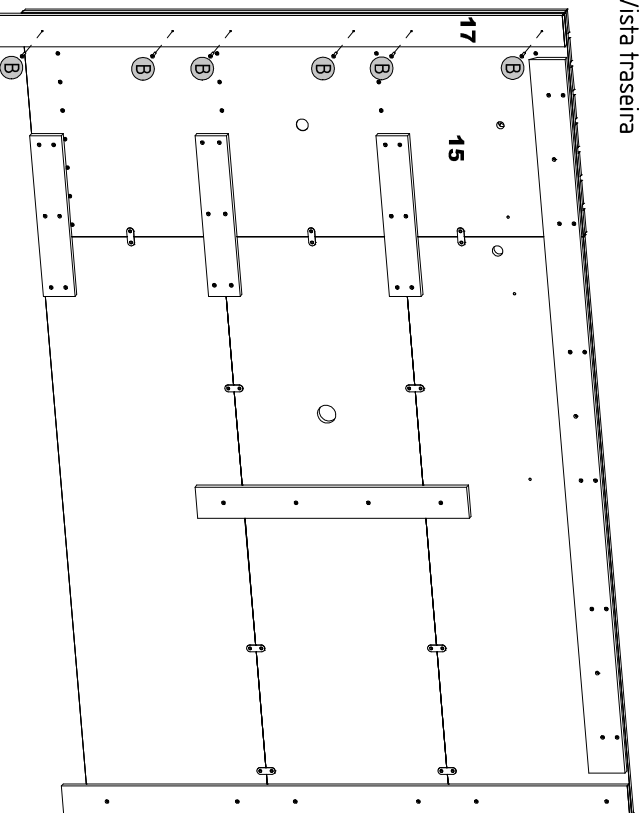

Passo 10

E	04x
5.0x50	
G	02x
6x30	
P	01x
O	01x
Branco	

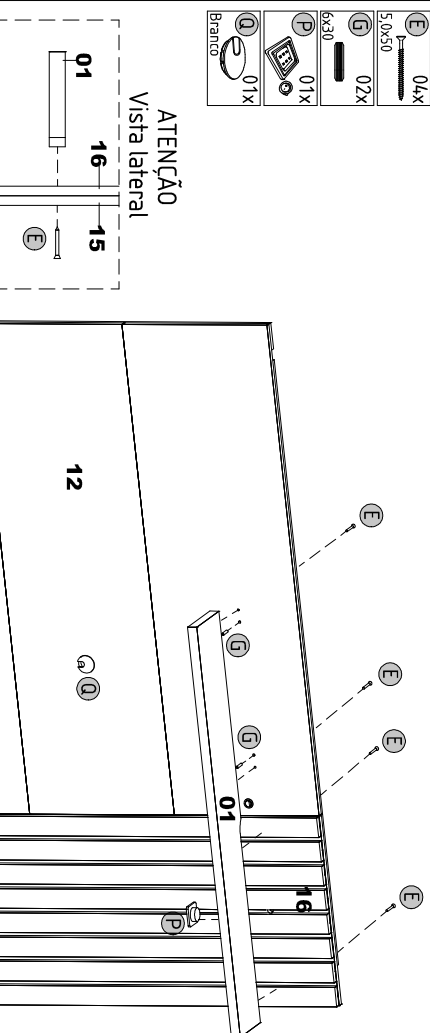

ATENÇÃO

Vista lateral

- Usar furação da peça 15 como guia.

- Peça 16 não contém furação, fazer o furo com o parafuso.

Passo 12

A	06x
3.5x14	
O	02x
O	01x
P	01x
Preto	

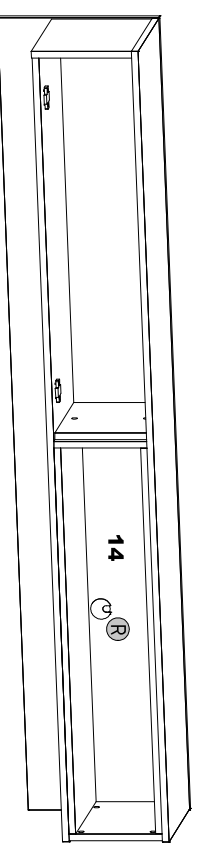

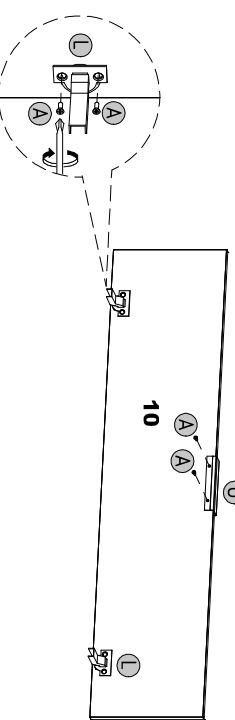

Vista interna







ETAPAS DA MONTAGEM / STAGES OF THE ASSEMBLY / ETAPAS DE LA ASAMBLEA

Para uma montagem perfeita do produto, siga a sequência:

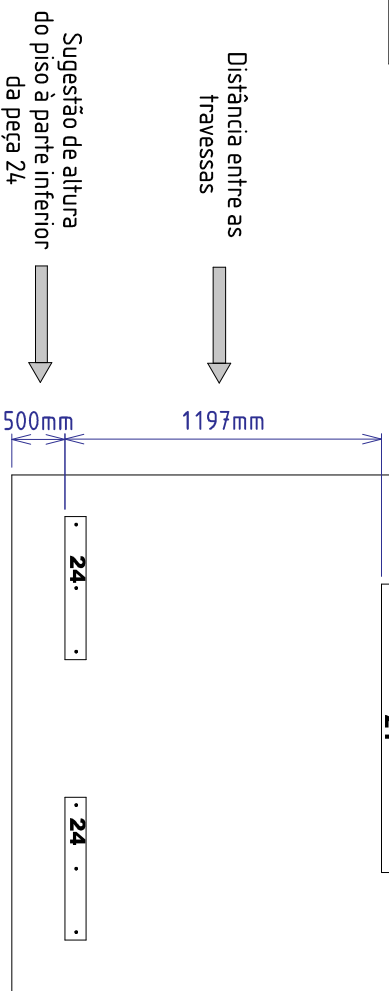
For a perfect product assembly, follow its sequence / Para un montaje perfecto del producto, sigue la secuencia.

Passo 13
 10x
 5.0x7.0
 10x



Passo 14
 02x
 5.0x7.0
 02x

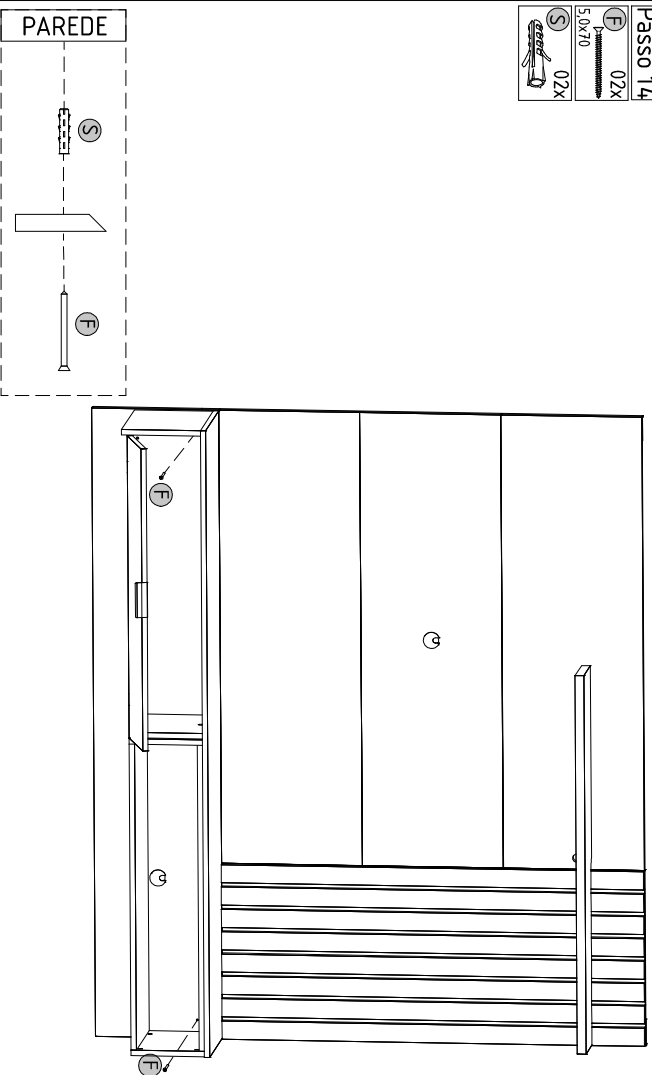

Medida Final

1800mm

1560mm

328mm

ATENÇÃO:

Fixar TV somente no painel.

O painel comporta TV de até 65"

PAREDE

