

# CO14402 - MÓDULO FORNO

Manual de Montagem  
 Assembly Instructions  
 Instrucción de Montaje

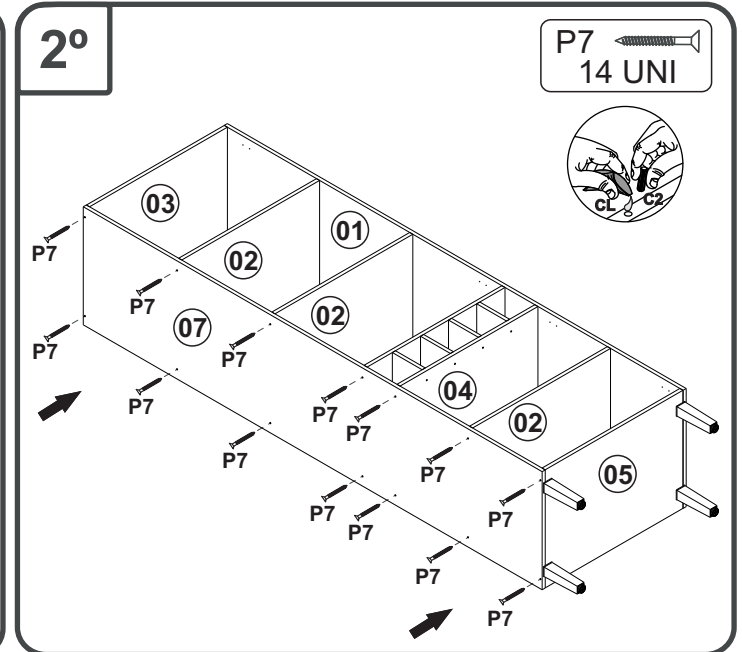
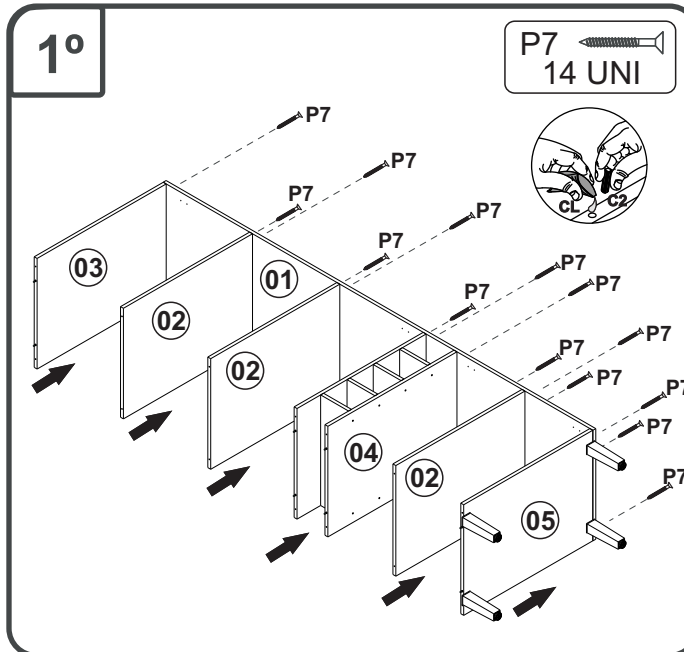
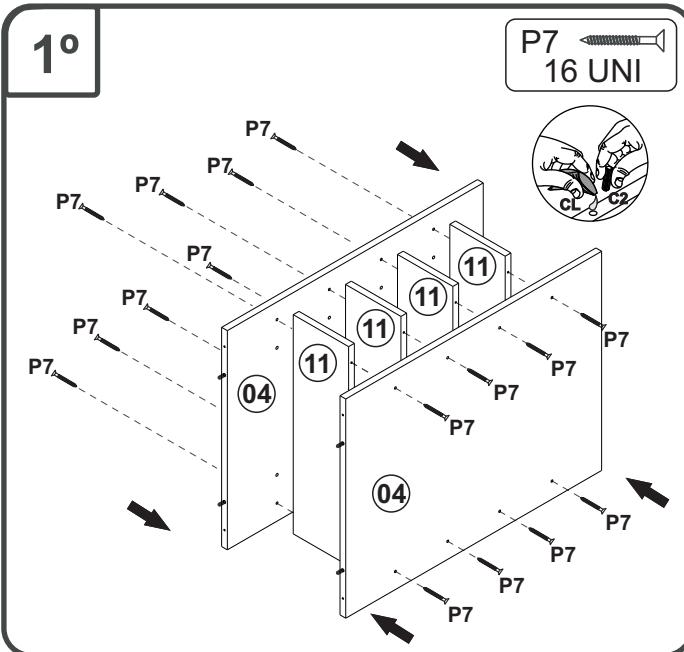
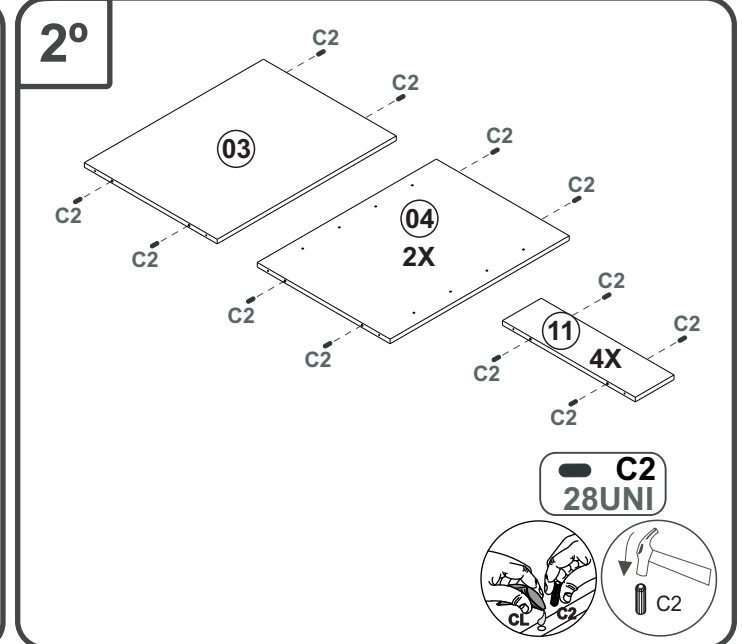
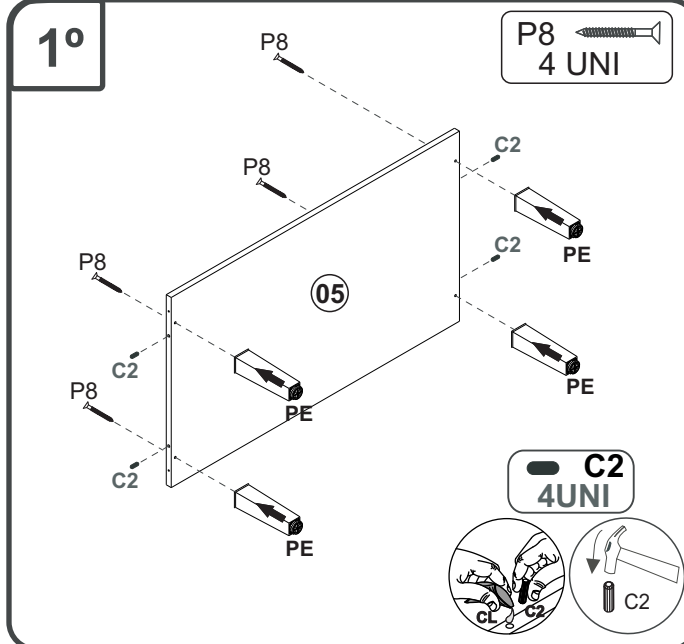
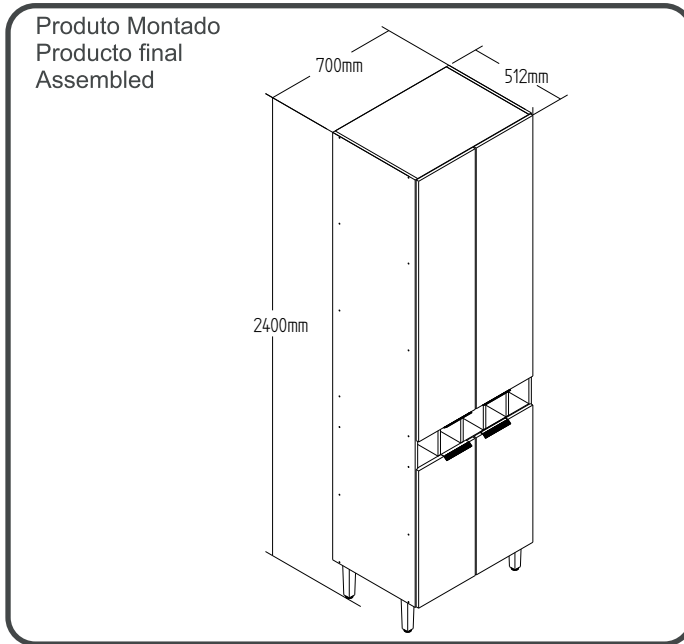

# CO14402 - MÓDULO FORNO

Manual de Montagem  
Assembly Instructions  
Instrucción de Montaje

decibal<sup>®</sup>  
móveis

06°

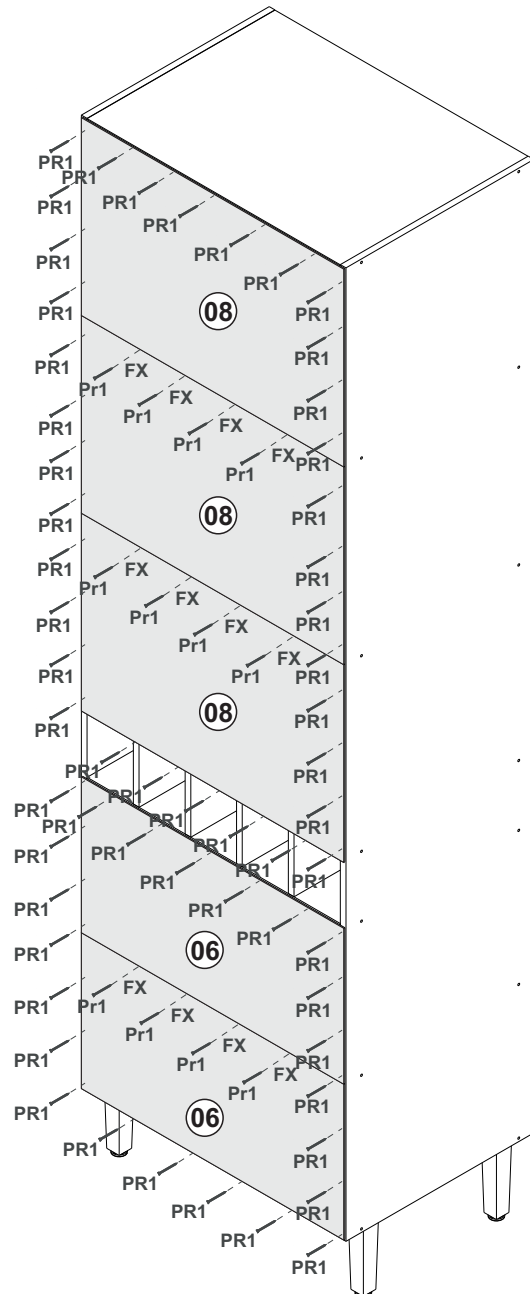
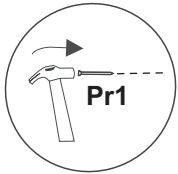

06°



\*PESO SUPORTADO.  
\*PESO SOPORTADO.  
\*WEIGHT SUPPORTED.

Fixação parede  
Fixed in the wall

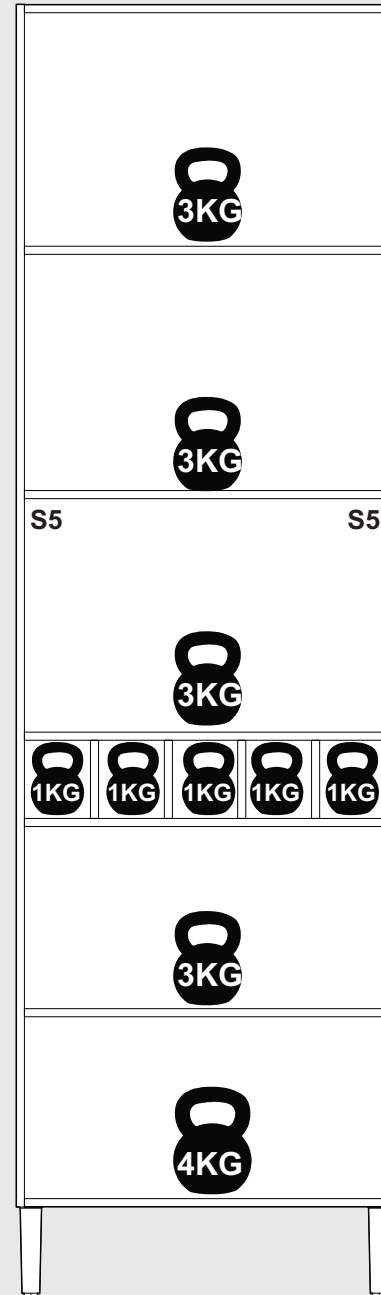
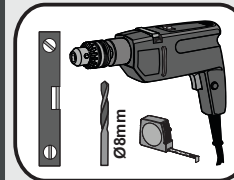
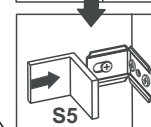
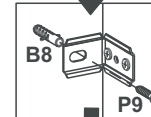
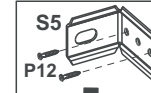

# CO14402 - MÓDULO FORNO

Manual de Montagem  
Assembly Instructions  
Instrucción de Montaje

**decibal**<sup>®</sup>  
móveis



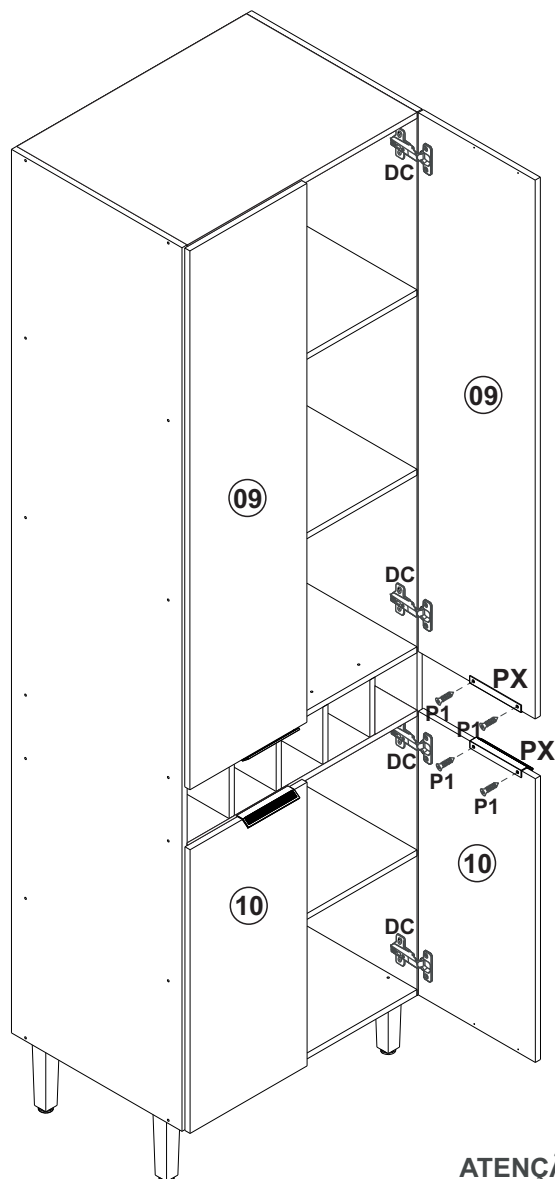



8°

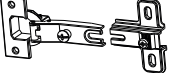

**ATENÇÃO!!!!**

MARCAÇÃO PRA O PRIMEIRO FURO DO PUXADOR  
MARCADO PARA EL PRIMER AGUJERO  
MARKING FOR THE FIRST HANDLE HOLE

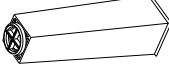
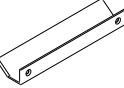
escala (N/A)









LEGENDA	DESCRIÇÃO/DESCRIPCIÓN/DESCRIPTION	CÓDIGO	QUANT.
<b>CL</b>	 COLA/PEGAMENTO/GLUE	01213	<b>01</b>
<b>ET</b>	 ETIQUETA LOGO DECIBAL/LABEL DECIBAL	01312	<b>01</b>
<b>AD</b>	 ADESIVO/ADHESIVO/ADHESIVE	15mm	<b>32</b>
<b>DC</b>	 DOBRADIÇA/BISAGRA/HINGE D=35mm C=Alta	12615 (AMORTECIMENTO)	<b>08</b>
<b>FX</b>	 FIXADOR COSTA/FIJADOR FONDO/FIXER COAST	01331	<b>20</b>
<b>S5</b>	 CAPA SUPORTE AÉREO /PORTADA APOYO AÉREO/AIR SUPPORT COVER	03828	<b>02</b>
<b>PE</b>	 PÉ/PATA/FOOT (170MM)	12003	<b>04</b>
<b>PX</b>	 PUXADOR/PEGADOR /HANDLE CHAMPANHE (AKEO 128MM)	12611	<b>04</b>
<b>B</b>	 BUCHA / BUJE / BUCHING 8 MM	01311	<b>02</b>
<b>BT</b>	 BATENTE/BATIENTE DE SILICONA/SILICONE STOP 8MM	02921	<b>08</b>

# CO14402 - MÓDULO FORNO

Manual de Montagem  
Assembly Instructions  
Instrucción de Montaje



## Ferragens/ Herrajes/ Hardware escala (1:1)

LEGENDA	DESCRIÇÃO/DESCRIPCIÓN/DESCRIPTION	CÓDIGO	QUANT.
<b>P7</b>	 PARAFUSO/TORNILLO/SCREW 4X45	01318	<b>44</b>
<b>PR1</b>	 PREGO/CLAVO/NAIL 10X10	01330	<b>92</b>
<b>C2</b>	 CAVILHA/TARUGO/DOWEL 6X30 MM	01211	<b>34</b>
<b>P12</b>	 PARAFUSO/TORNILLO/SCREW 3,5X13 CABEÇA FLANGEADA	09927	<b>52</b>
<b>P9</b>	 PARAFUSO/TORNILLO/SCREW 6X50	03827	<b>02</b>
<b>P1</b>	 PARAFUSO/TORNILLO/SCREW 3,5X12	01328	<b>08</b>
<b>P8</b>	 PARAFUSO/TORNILLO/SCREW 5X45	01320	<b>04</b>
<b>PU</b>	 PARAFUSO UNIÃO/UNIÓN DETORNILLO /SCREW UNION	01495	<b>02</b>

## Relação de Peças/ Relación de Piezas/Parts List

Nº	CÓDIGO/CODE	DESCRIÇÃO/DESCRIPCIÓN/DESCRIPTION	QTD/CANT	VOL.
1	0560962	LATERAL DIR/LATERAL/SIDE 2230X497X15MM	1,00	1
2	0560966	PRATELEIRA/ESTANTE/SHELF 670X497X15MM	3,00	1
3	0560964	BASE SUP 670X497X15MM	1,00	1
4	0560965	PRATELEIRA ADEGA/ESTANTE/SHELF 670X497X15MM	2,00	1
5	0560961	BASE INF 670X497X15MM	1,00	1
6	0560970	COSTA INF/REVÉS/BACK 694X357X2,8MM	2,00	1
7	0560963	LATERAL ESQ/LATERAL/SIDE 2230X497X15MM	1,00	1
8	0560971	COSTA SUP/REVÉS/BACK 694X453X2,8MM	3,00	1
9	0560968	PORTA SUP/PUERTA/DOOR 1360X341X15MM	2,00	2
10	0560967	PORTA INF/PUERTA/DOOR 716X341X15MM	2,00	2
11	0560969	DIVISORIA ADEGA/DIVIDER 497X145X15MM	4,00	2

**ATENÇÃO!!!! montadores e consumidores**  
\* Ajustar o torque da parafusadeira para não danificar as peças escareando o parafuso \*  
**ATENCIÓN!!!! montadores e consumidores**  
\* Ajuste el torque del destornillador para no dañar las piezas avallanando el tornillo \*  
**ATTENTION!!!! assemblers and consumers**  
\* Adjust the torque of the screwdriver so as not to damage the parts by countersinking the screw \*

Ferramentas necessárias  
Necessary tools  
Herramientas necesarias

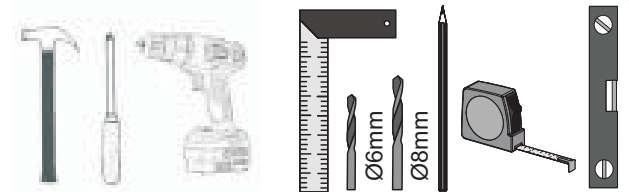

**ATENÇÃO!!!! montadores e consumidores**  
\* Para limpar o móveis utilize somente um pano úmido (umedecido em água pura ou água com sabão neutro). Depois, passe um pano seco. Evite a umidade excessiva.  
\* Evite usar álcool, água sanitária, detergente e outros produtos químicos, mesmo diluídos em água. Não utilize produtos abrasivos de nenhuma espécie

**ATENCIÓN!!!! montadores e consumidores**  
\* Para limpiar el mueble utilice solamente un paño húmedo (humedecido con agua limpia o con un jabón suave). A continuación, utilice un paño seco. Evite el exceso de humedad.  
\* Evite uso de alcohol, hipocloritro solución basada, detergente y otros productos químicos, mismo diluídos en agua. No utilice productos abrasivos de ningún tipo.

**ATTENTION!!!! assemblers and consumers**  
\* To clean the furniture, use only a damp cloth (humidify it only in pure water ou water and neutral soap). After, use a dry cloth. Avoid excessive humidity.  
\* Avoid using alcohol, bleach, detergent and other chemical products, even diluted in water. Do not use any kind of abrasive cleaning agents to clean the furniture.  
The use of such products may jeopardize the ?nal characteristics of the furniture.

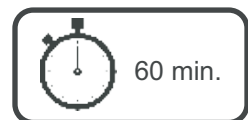

[www.decibal.com.br](http://www.decibal.com.br)



Medida em mm