

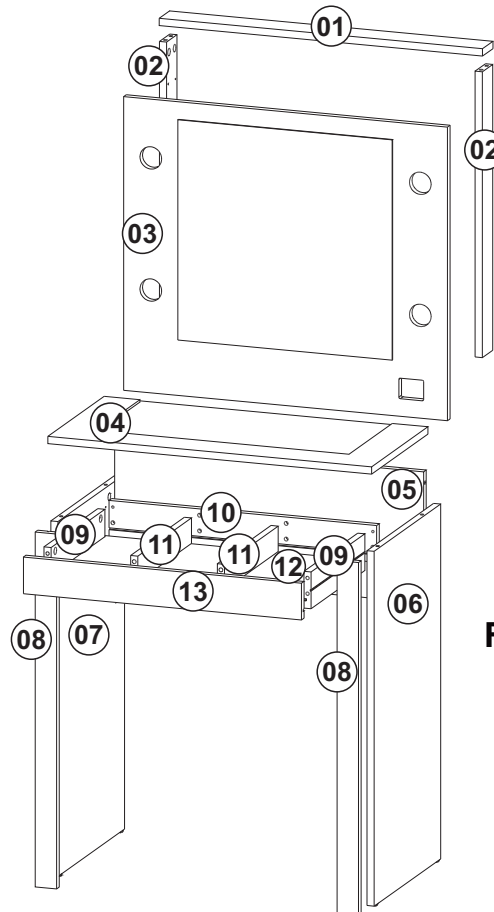

### Lista de Peças / List of pieces / Lista de piezas

CóD	DESCRIÇÃO	DESCRIPTION	DESCRIPCION	QTD	RAW MATERIAL	DIMENSION
01	Tampo Espelho	Glass Top	Tapa Espejo	1	MDP 15mm	679x60x15
02	Lateral Espelho	Glass Side	Lateral Espejo	2	MDP 15mm	584x60x15
03	Painel	Panel	Panel	1	MDP 15mm	680x600x75
04	Tampo	Top	Tapa	1	MDP 15mm	680x325x15
05	Costa	Back	Costa	1	MDP 15mm	649x268x15
06	Lateral Direita	Right Side	Lateral Derecha	1	MDP 15mm	725x384x15
07	Lateral Esquerda	Left Side	Lateral Izquierda	1	MDP 15mm	725x384x15
08	Travessa	Traverse	Traviessa	2	MDP 15mm	725x45x15
09	Lateral Gaveta	Side Drawer	Lateral de Cajón	2	MDP 15mm	310x75x15
10	Costa Gaveta	Drawer Back	Costa de Cajón	1	MDP 15mm	562x75x15
11	Divisão Gaveta	Drawer Division	Division de Cajón	2	MDP 15mm	310x52x15
12	Fundo Gaveta	Drawer Botton	Fondo de Cajón	1	MDP 3mm	540x318x3
13	Frente Gaveta	Drawer Front	Frente cajón	1	MDP 15mm	584x75x15



#### Notas Especiais:

**01** -Examine completamente todas as peças do móvel antes de começar o trabalho.

**02** -Recomenda-se montar o móvel conforme este Manual de Montagem.

**03** -É de responsabilidade do montador seguir as instruções do Manual de Montagem, que são fundamentais para garantir a estrutura do móvel.

**04** -Para limpeza, utilizar somente pano úmido e sabão neutro.

#### Special notes:

**01** -Check all parts of the unit thoroughly before starting work.

**02** -It is recommended to assemble the furniture according to this Installation Manual.

**03** -It is the responsibility of the assembler to follow the instructions in the Assembly Manual, which are essential to ensure the structure of the furniture.

**04** -For cleaning use only damp cloth and neutral soap.

#### Notas especiales:

**01** -Examine completamente todas las piezas del mueble antes de iniciar el trabajo.

**02** -Se recomienda montar el mueble conforme el Manual de Ensamblaje.

**03** -Es de responsabilidad del montador seguir las instrucciones del Manual de Ensamblaje, que son fundamentales para garantizar la estructura del mueble.

**04** -Para limpieza solamente usar trapo húmedo y jabón neutro.

#### Guarante certificate:

The guarantee of products manufactured by Móveis Videira LTDA covers any defects / manufacturing defects, within the period established by the Consumer Protection Code, in its Article 26, II, which provides for a legal guarantee of ninety (90) days.



### Ferramentas | Tools | Herramientas

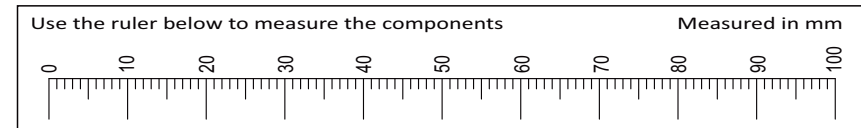
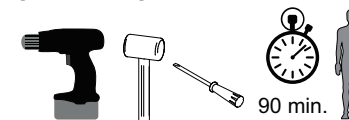

### TAMANHO REAL - TAMANO VERDADERO - REAL SIZE

REF	DESCRIÇÃO	QTD
A	Cavilha 8 x 30mm	12
B	4 x 16mm CC	44
C	3,5 x 14mm CF	12

### ILUSTRAÇÃO - ILUSTRACION - ILLUSTRATION

REF	DESCRIÇÃO	QTD
D	34 x 7mm Parafuso Minifix	18
E	15 x 12mm Tambor Minifix	18
F	Adesivo Tapa Furo	04
G	14 x 4mm Sapata Deslizadora	04
H	22 x 3mm Pregos 10x10	04
I	22x17x12mm Suporte angular	06
J	12 x 12 x 12mm Cantoneira 2 Furos	05
K	Interruptor 10A Kit Lâmpadas	01
L	32x45x20mm Distanciador de corredeira	04
M	55 x 19mm Passa Fio	04
N	Tampa p/ Passa Fio	04
O	300 mm Corredeira Telescópica	01
P	40x40x1mm Junção de Tampo	02

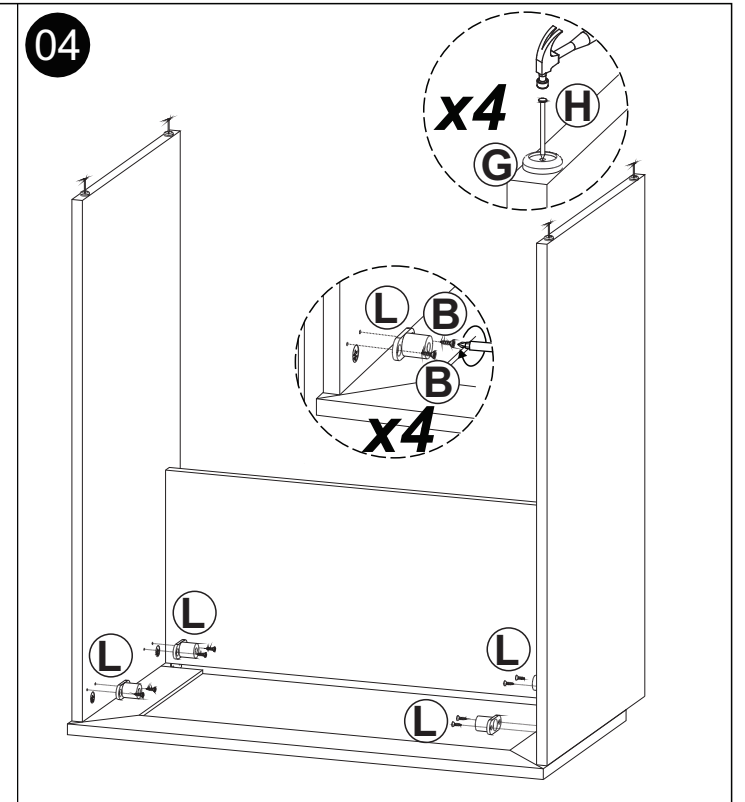
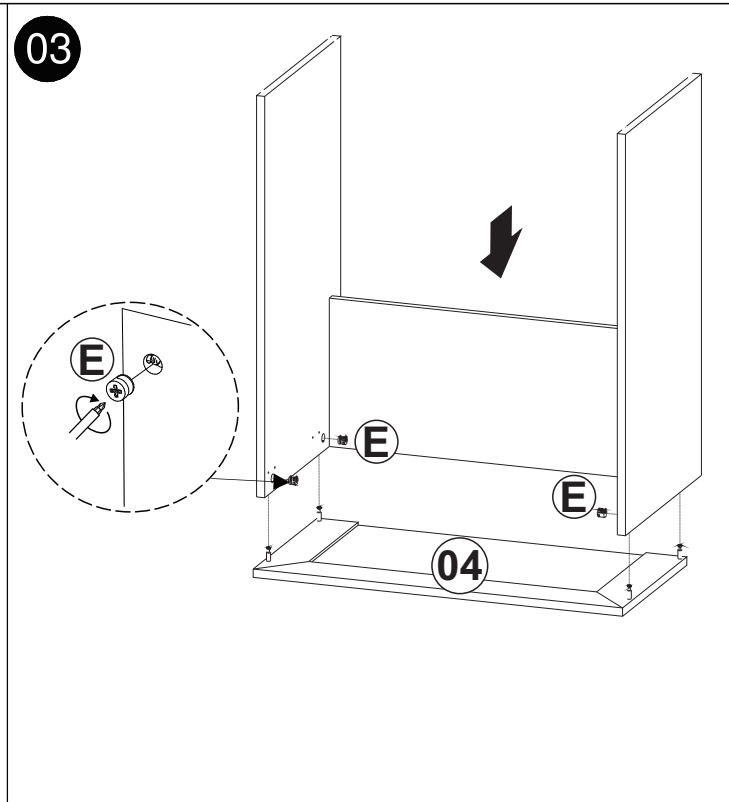
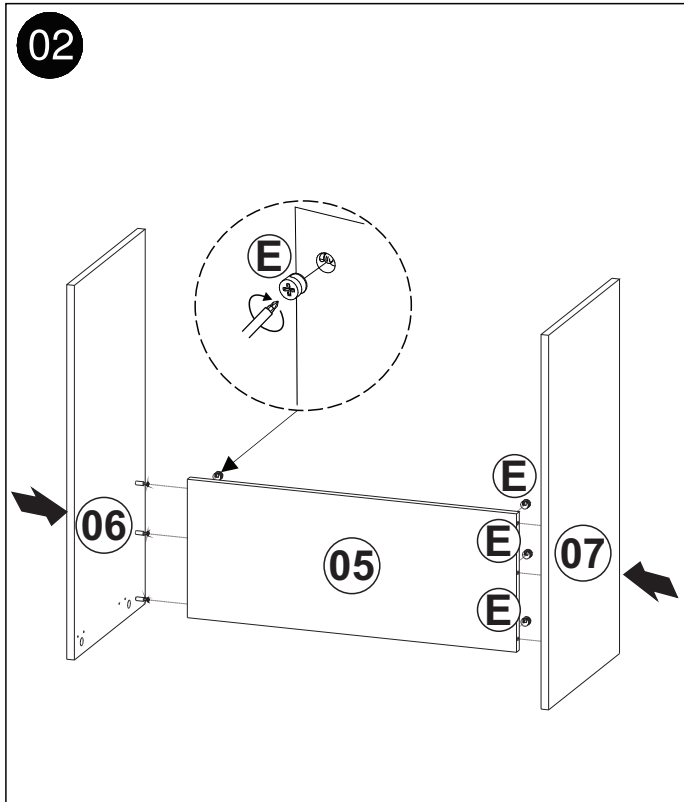
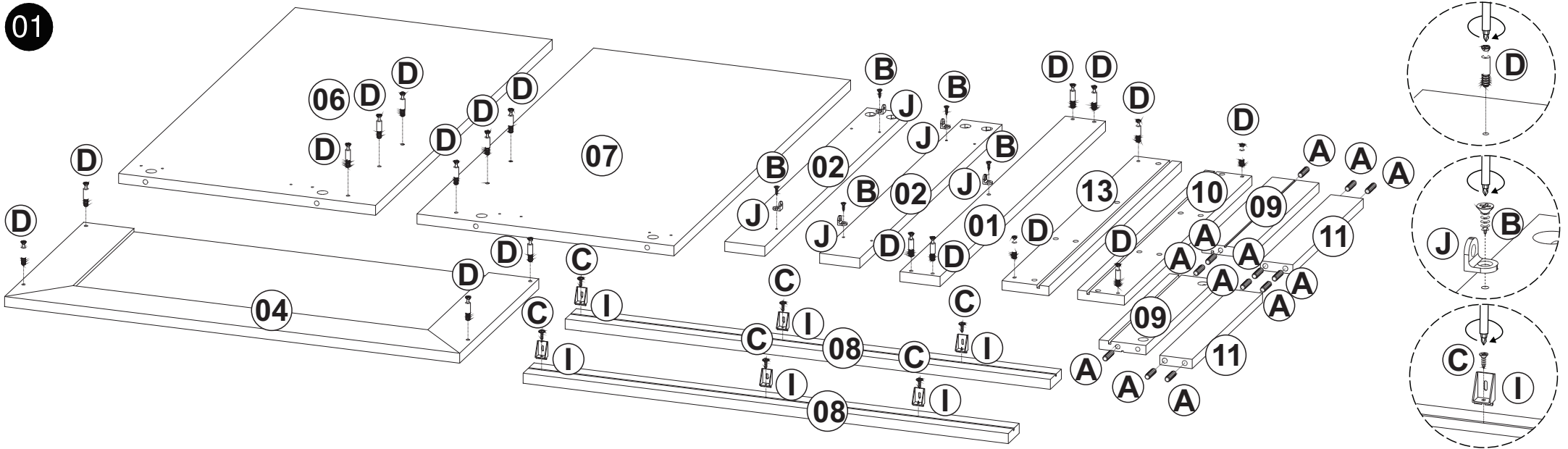

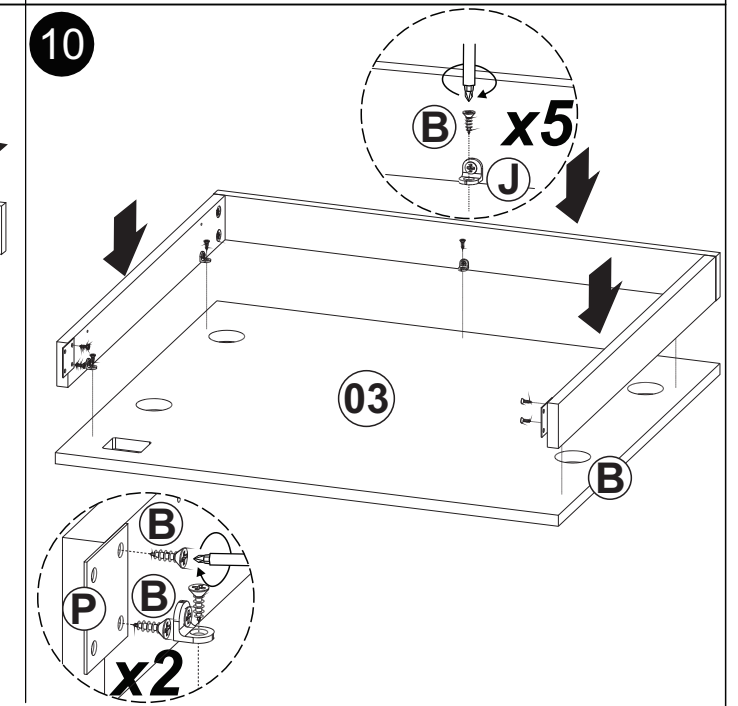
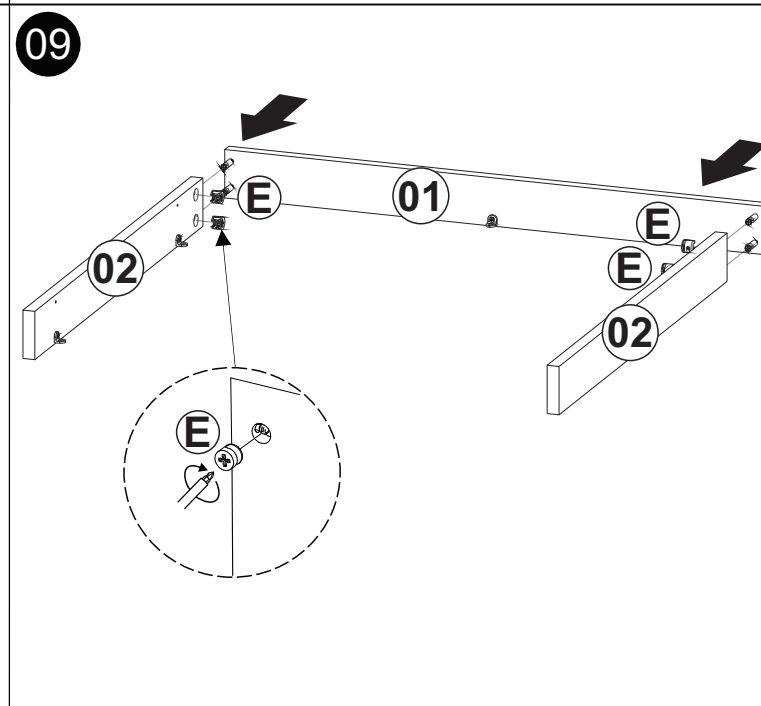
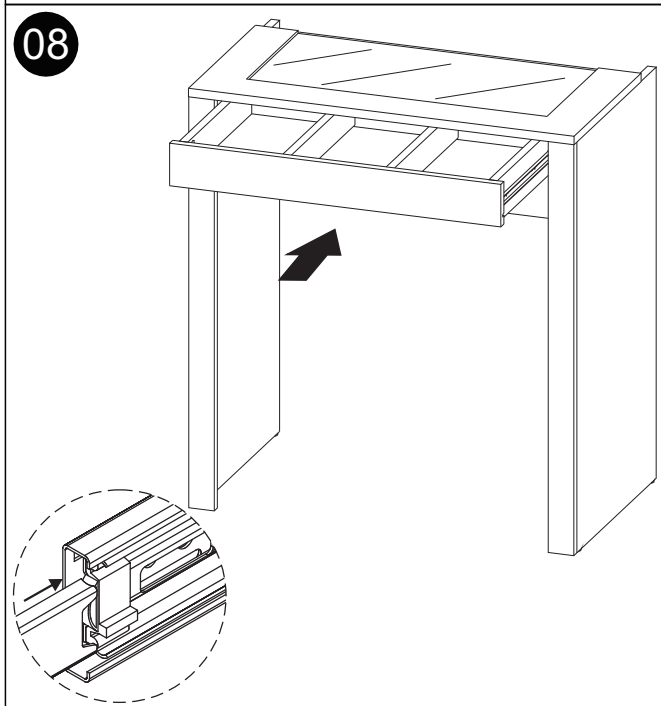
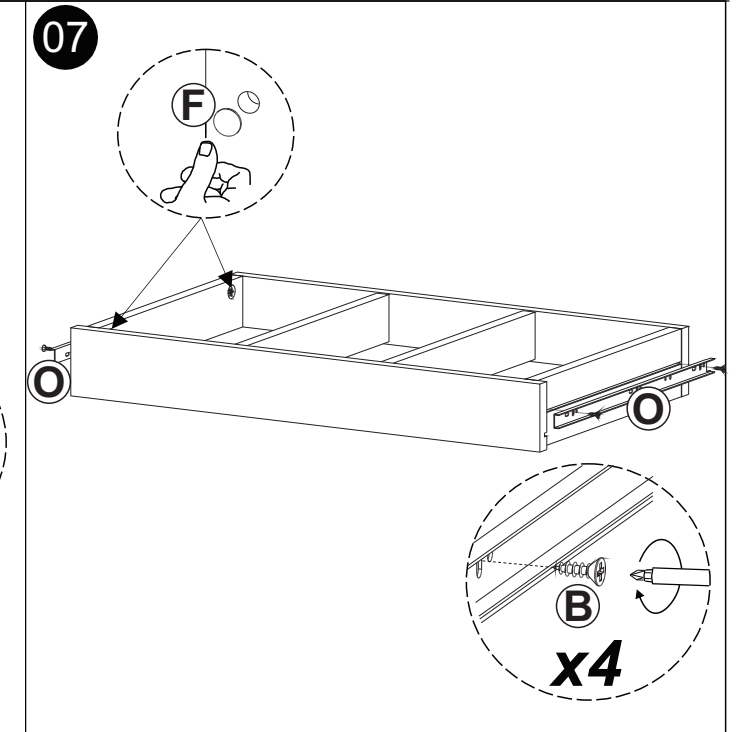
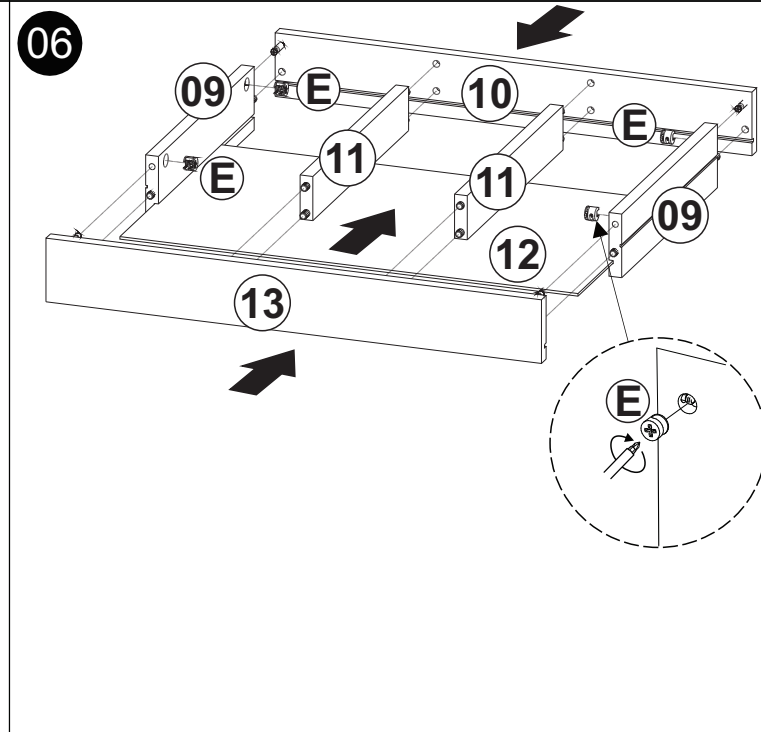
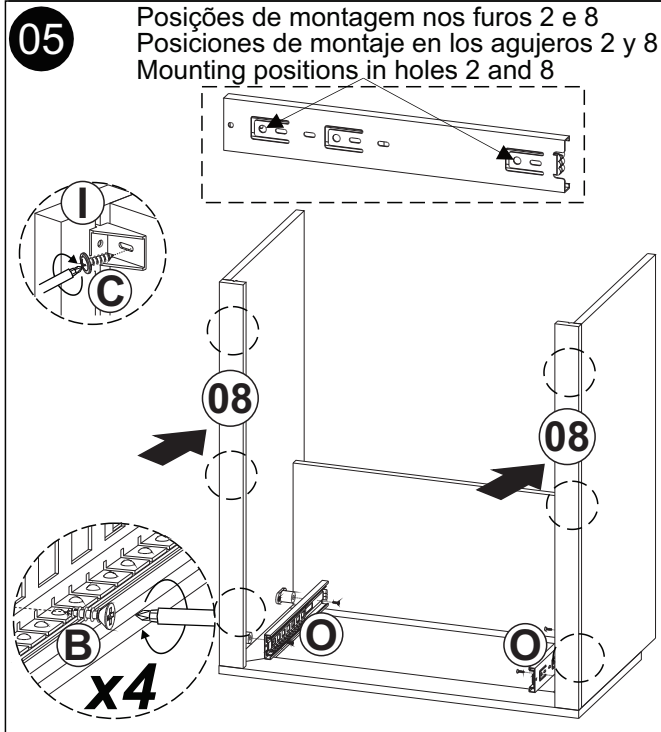

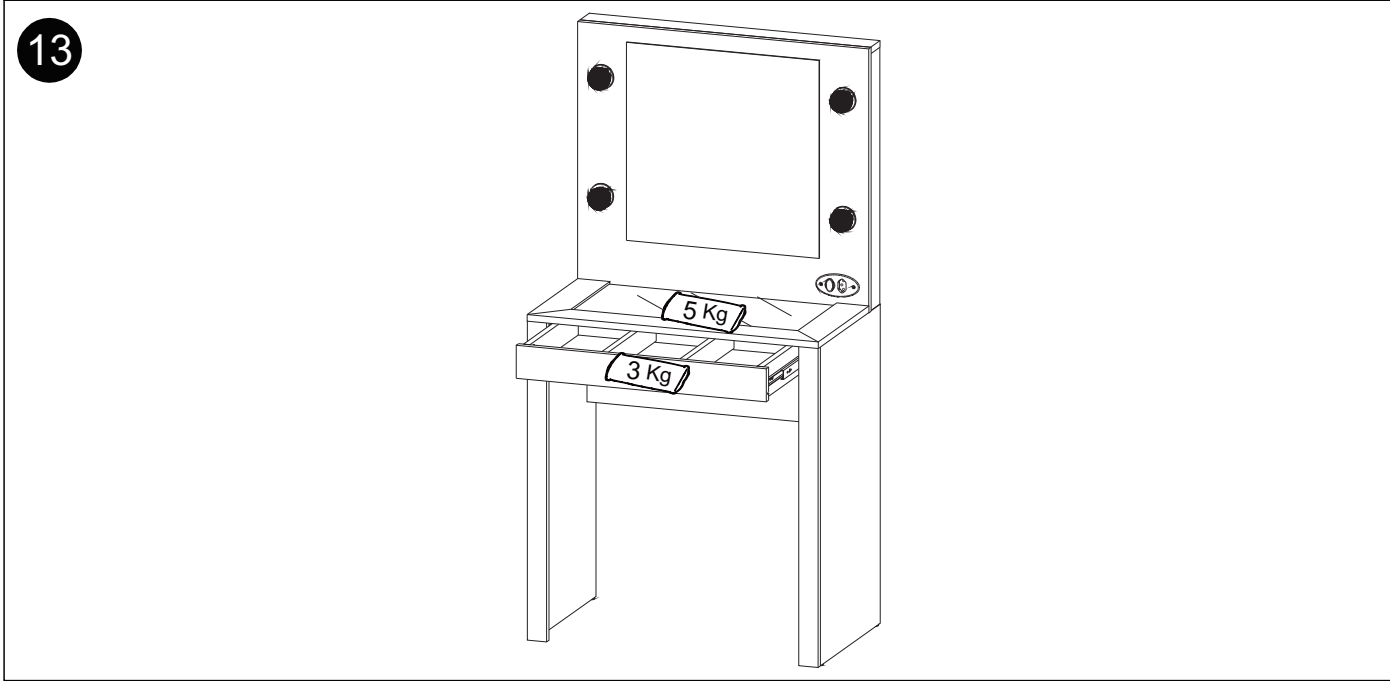
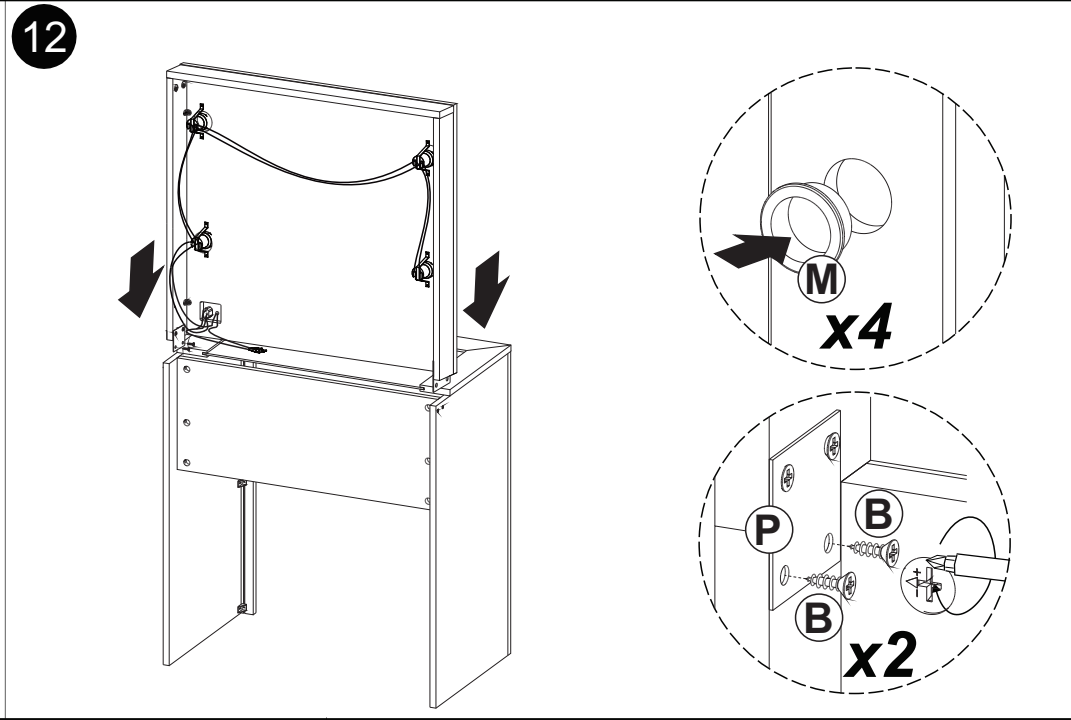
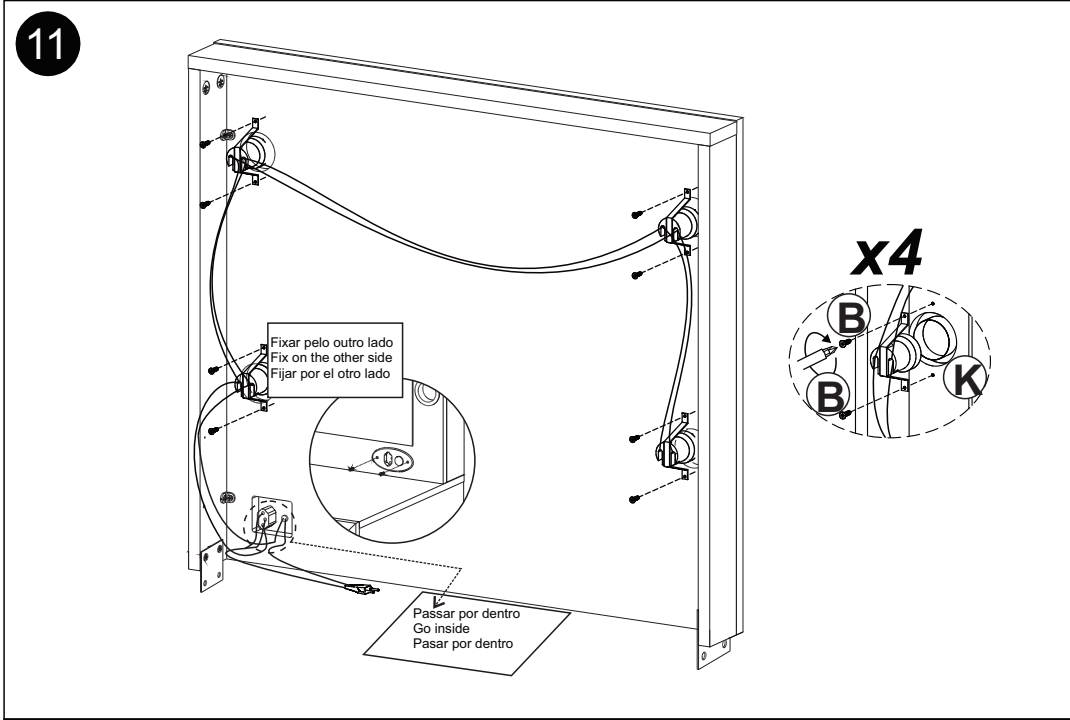

1. Podem ser utilizadas 4 (quatro) lâmpadas 127v ou 220v, de acordo com a voltagem utilizada no local. / 4 (four) 127v or 220v bulbs may be used, depending on the voltage used at the location. / Pueden utilizarse 4 (cuatro) lámparas 127v o 220v, según el voltaje utilizado en el lugar.
  2. Deve ser utilizado lâmpadas LEDAMARELA (até 10 watts), ideal para maquiagem. / YELLOW LED bulbs (up to 10 watts), ideal for makeup. / Debe utilizarse lámparas LEDAMARILLA (hasta 10 vatios), ideal para el maquillaje.
  3. Não pode utilizar lâmpadas incandescentes para evitar o aquecimento da madeira. / You can not use incandescent bulbs to avoid wood heating. / No puede utilizar lámparas incandescentes para evitar el calentamiento de la madera.
  4. Caso não queira utilizar lâmpadas, no kit de ferragens você encontrará 4 (quatro) esferas elípticas para cobrir os soquetes, servindo também como proteção contra choques elétricos. / If you do not want to use light bulbs in the hardware kit you will find 4 (four) elliptical beads to cover the sockets, also serving as protection against electric shock. / Si no desea utilizar lámparas, en el kit de herrajes usted encontrará 4 (cuatro) esferas elípticas para cubrir los zócalos, sirviendo también como protección contra golpes eléctricos.
- ou  
 or
-