

ASSEMBLY INSTRUCTIONS MANUAL DE MONTAGEM / INSTRUCCIONES DE ARMADO

BLUM DRESSING TABLE
PENTEADEIRA BLUM
TOCADOR BLUM

Reference
Referência
Referencia

220126

Revised
Revisão
Revisión

00



ENGLISH
PORTUGUÊS
ESPAÑOL

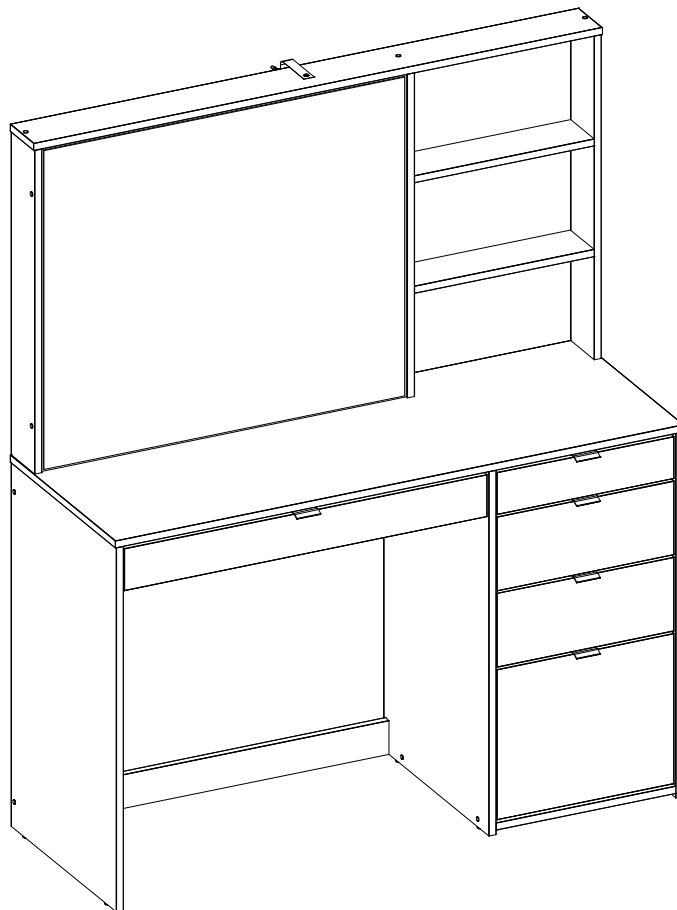

MAXIMUM RECOMMENDED WEIGHT
BEING THIS EVENLY DISTRIBUTED.

PESO MÁXIMO RECOMENDADO SENDO
ESTE DISTRIBUÍDO UNIFORMEMENTE.

PESO MÁXIMO RECOMENDADO SIENDO
ESTE UNIFORMEMENTE DISTRIBUIDO.

	LB	KG
–		
A	2	1
C	6	3
G	33	15

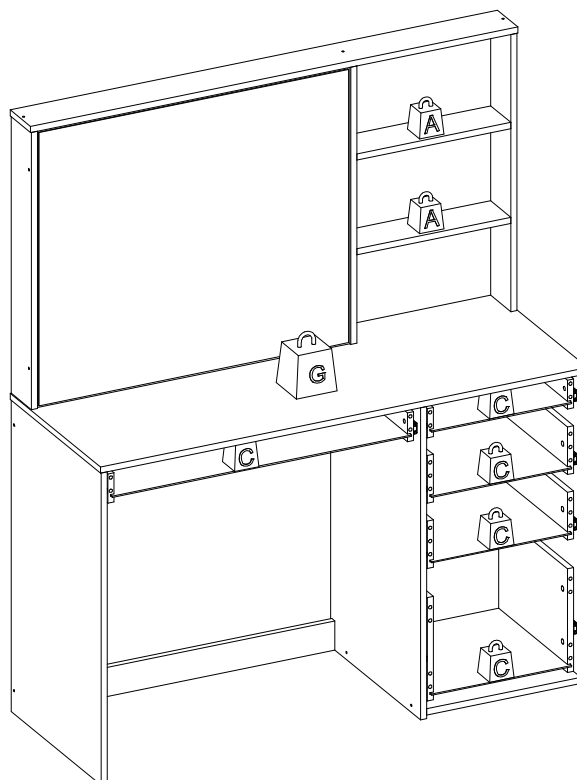

Nº	Measures_Inches	Medidas_cm	Qty./Qtd.
01	47 3/8 x 3 7/8 x 5/8	120.2 x 10.0 x 1.5	1
02	15 x 3 7/8 x 5/8	38.0 x 10.0 x 1.5	2
03	47 3/8 x 17 1/2 x 5/8	120.2 x 44.5 x 1.5	1
04	15 x 17 1/2 x 5/8	38.0 x 44.5 x 1.5	1
05	26 3/8 x 3 7/8 x 5/8	67.0 x 10.0 x 1.5	1
06	26 3/8 x 3 7/8 x 5/8	67.0 x 10.0 x 1.5	1
07	26 3/8 x 3 7/8 x 5/8	67.0 x 10.0 x 1.5	1
08	29 5/8 x 17 1/2 x 5/8	75.4 x 44.5 x 1.5	1
09	2 3/4 x 30 3/8 x 5/8	7.0 x 77.3 x 1.5	2
10	29 5/8 x 17 1/2 x 5/8	75.4 x 44.5 x 1.5	1
11	29 5/8 x 17 1/2 x 5/8	75.4 x 44.5 x 1.5	1
12	26 3/8 x 30 3/8 x 5/8	67.0 x 77.3 x 1.5	1
13	30 1/4 x 3 3/8 x 5/8	76.7 x 8.7 x 1.5	1
14	14 3/4 x 3 3/8 x 5/8	37.4 x 8.7 x 1.5	1
15	14 3/4 x 6 x 5/8	37.4 x 15.3 x 1.5	2
16	14 3/4 x 12 1/4 x 5/8	37.4 x 31.1 x 1.5	1
17	28 1/2 x 2 3/4 x 5/8	72.4 x 7.0 x 1.5	1
18	13 x 2 3/4 x 5/8	33.1 x 7.0 x 1.5	1
19	13 x 4 1/2 x 5/8	33.1 x 11.5 x 1.5	2
20	13 x 9 7/8 x 5/8	33.1 x 25.0 x 1.5	1
21	14 x 9 7/8 x 5/8	35.5 x 25.0 x 1.5	1
22	14 x 9 7/8 x 5/8	35.5 x 25.0 x 1.5	1
23	29 x 13 3/4 x 1/8	73.8 x 34.9 x 0.3	1
24	13 3/4 x 13 5/8 x 1/8	34.9 x 34.5 x 0.3	1
25	13 7/8 x 13 5/8 x 1/8	35.4 x 34.5 x 0.3	3
26	27 x 15 3/4 x 1/8	68.7 x 40.0 x 0.3	1
27	29 3/8 x 15 3/4 x 1/8	74.7 x 40.0 x 0.3	1
96	14 x 4 1/2 x 5/8	35.5 x 11.5 x 1.5	2
97	14 x 4 1/2 x 5/8	35.5 x 11.5 x 1.5	2
112	13 3/4 x 2 3/4 x 5/8	35.0 x 7.0 x 1.5	2
113	13 3/4 x 2 3/4 x 5/8	35.0 x 7.0 x 1.5	2

PARTS IDENTIFICATION IDENTIFICAÇÃO DAS PEÇAS / IDENTIFICACIÓN DE LAS PIEZAS

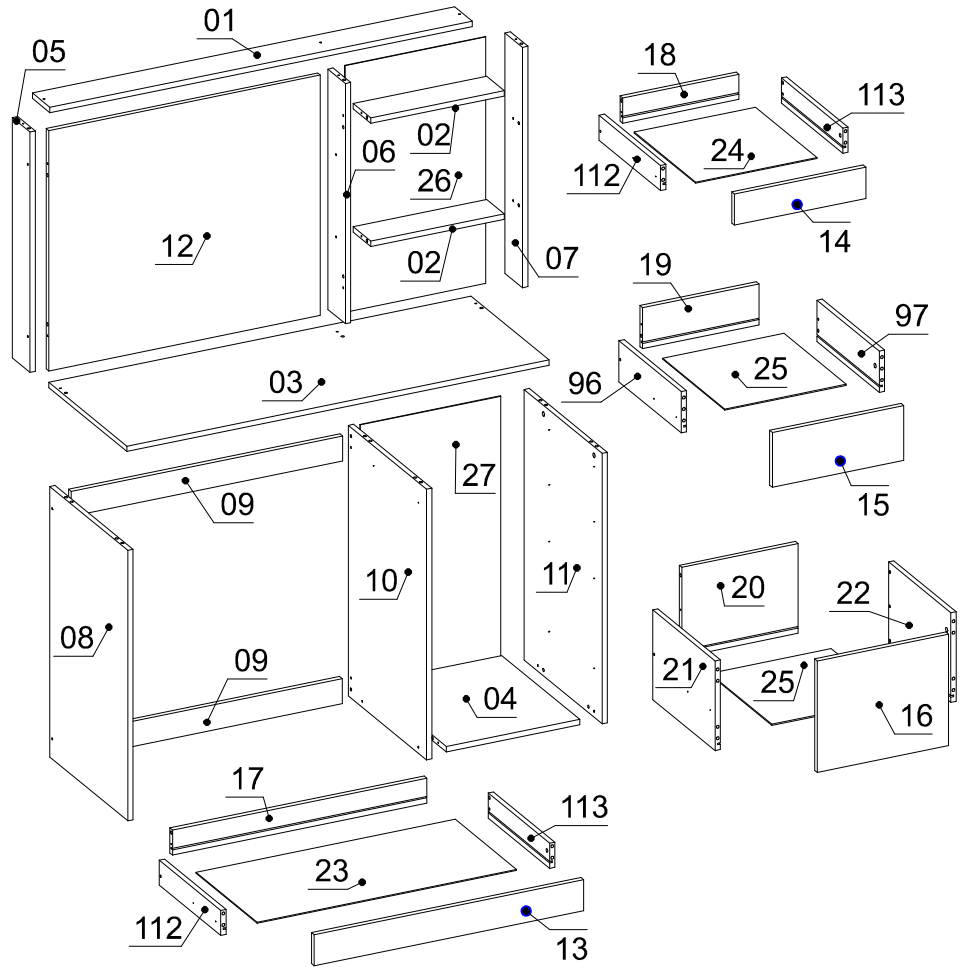

YOU WILL NEED / VOCÊ VAI PRECISAR DE / USTED NECESITARÁ

Tools not supplied / Ferramentas não fornecidas / Herramientas no incluidas

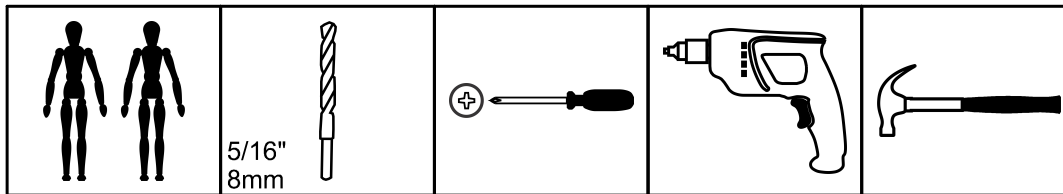

2 People
2 Pessoas
2 Personas

5/16"
8mm
Drill bit
Broca
Taladro

Screwdriver Phillips
Chave Phillips
Destornillador cruz

Drill machine
Furadeira
Taladro

Hammer
Martelo
Martillo















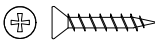
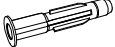



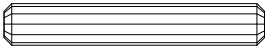
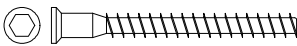

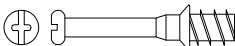
The separation of the accessories before you start the assembly will facilitate the same. In case of doubt on the size of the screws and bolts, use the ruler to bottom of page 3.

A separação dos acessórios antes de iniciar a montagem facilitará a mesma. Em caso de dúvida no tamanho dos parafusos e cavilhas, utilize a régua ao final da página 3.

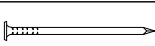
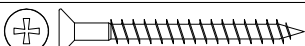
La separación de los accesorios antes de comenzar el armado facilitará el mismo. En caso de duda sobre el tamaño de los tornillos y taquetes, utilice la regla al pie de página 3.

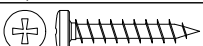
IDENTIFICATION OF ACCESSORIES IDENTIFICAÇÃO DOS ACESSÓRIOS/ IDENTIFICACIÓN DE ACCESORIOS

A		Flanged head screw / Parafuso flangeado / Tornillo de cabeza flangeada	5,0x60 mm	1
A1		Glue / Cola / Pegamento	13 g	1
A2		Small plastic foot / Sapata redonda / Pie plástico	14 mm	6
A3		Trapeze / Trapézio / Trapecio	-	4
A8		Flat head screw / Parafuso chato / Tornillo de cabeza plana	3,5x20 mm	4
B3		Bushing / Bucha expansiva / Tapón	8x50 mm	1
C1		Metal claw / Garra de metal / Garra metal	-	2
E		Wooden dowel / Cavilha / Taquete	8x30 mm	54
E9		Strap / Cinta / Correa	-	1
F		Wooden dowel / Cavilha / Taquete	8x50 mm	3
G		Structural screw / Parafuso estrutural / Tornillo estructural	5,0x50 mm	22
H		Allen key / Chave allen / Liave allen	3 mm	1
I		Structural screw cover/Tampa parafuso estrutural/Tapa tornillo estructural	-	15
J		Simple minifix screw / Haste minifix simples / Tornillo minifix simple	-	14
L		Drum lock / Tambor minifix / Tambor minifix	12 mm	14
L9		Flat head screw / Parafuso chato / Tornillo de cabeza plana	3,5x12 mm	51
L17		Telescopic slide / Corrediça telescópica / Corredera telescópica	350 mm	10
M		Bore patch adhesive / Tapa furo adesivo / Tapones adhesivo	-	8
N		Nail / Prego / Clavo	10x10	46
O		Flat head screw / Parafuso chato / Tornillo de cabeza plana	4,5x45 mm	10
o1		Triangular support / Suporte triangular / Soporte triangular	-	4
P		Pan head screw / Parafuso panela / Tornillo de pan	4,5x25 mm	4
S2		Handle / Puxador metálico / Tirador	-	5



PRE-ASSEMBLE
PRÉ-MONTAGEM / PRE ARMADO

01

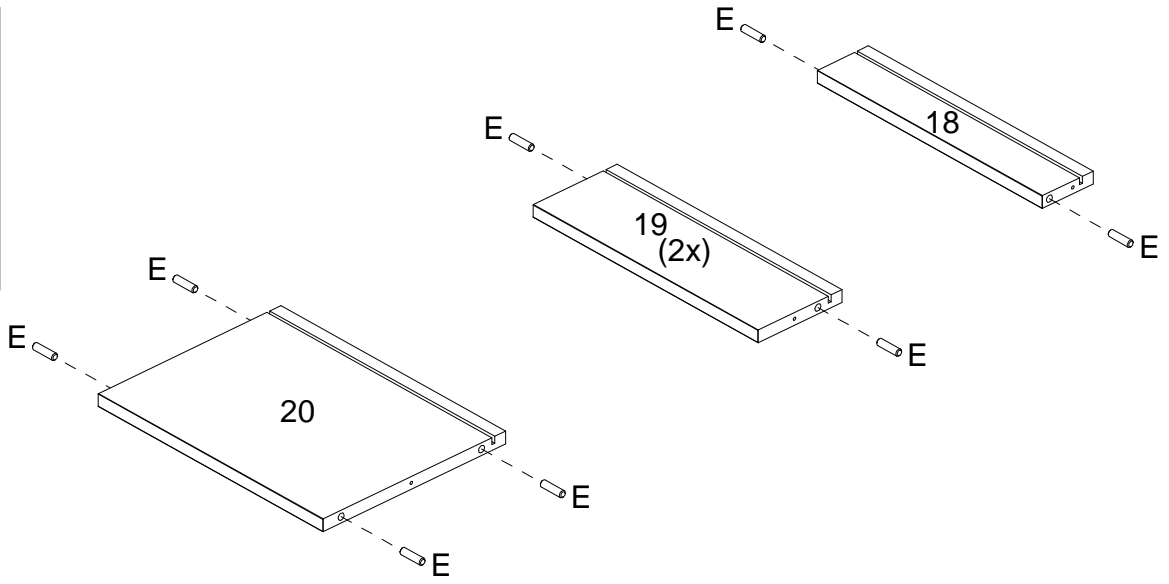
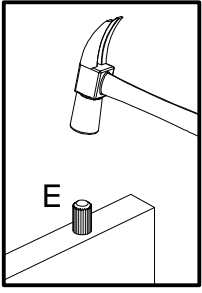

02

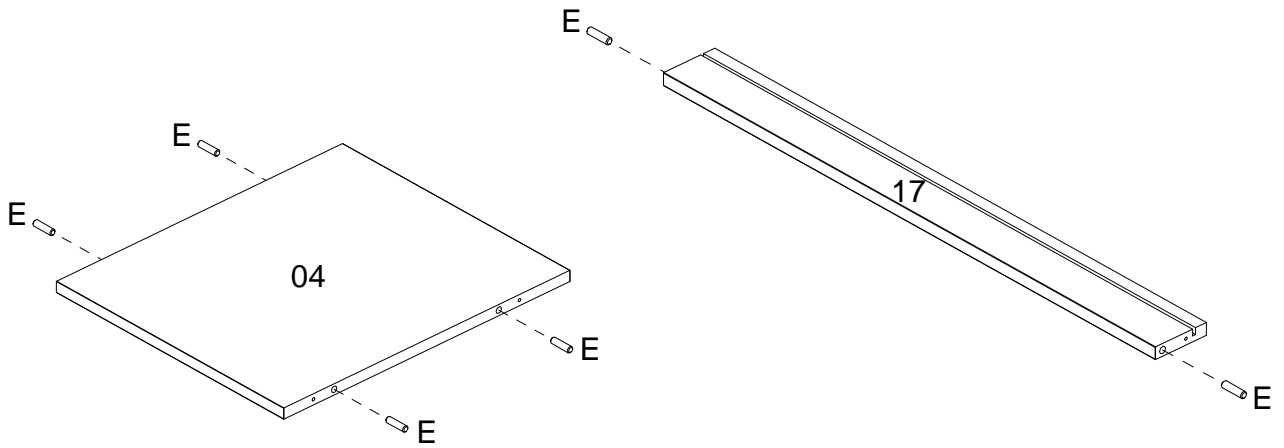

03

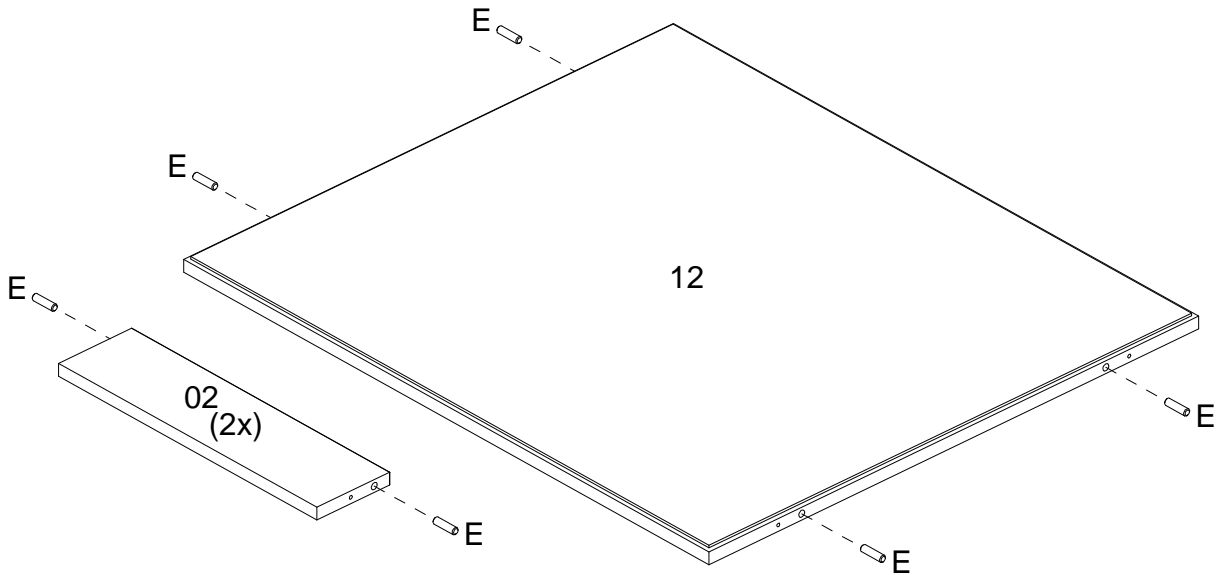

04

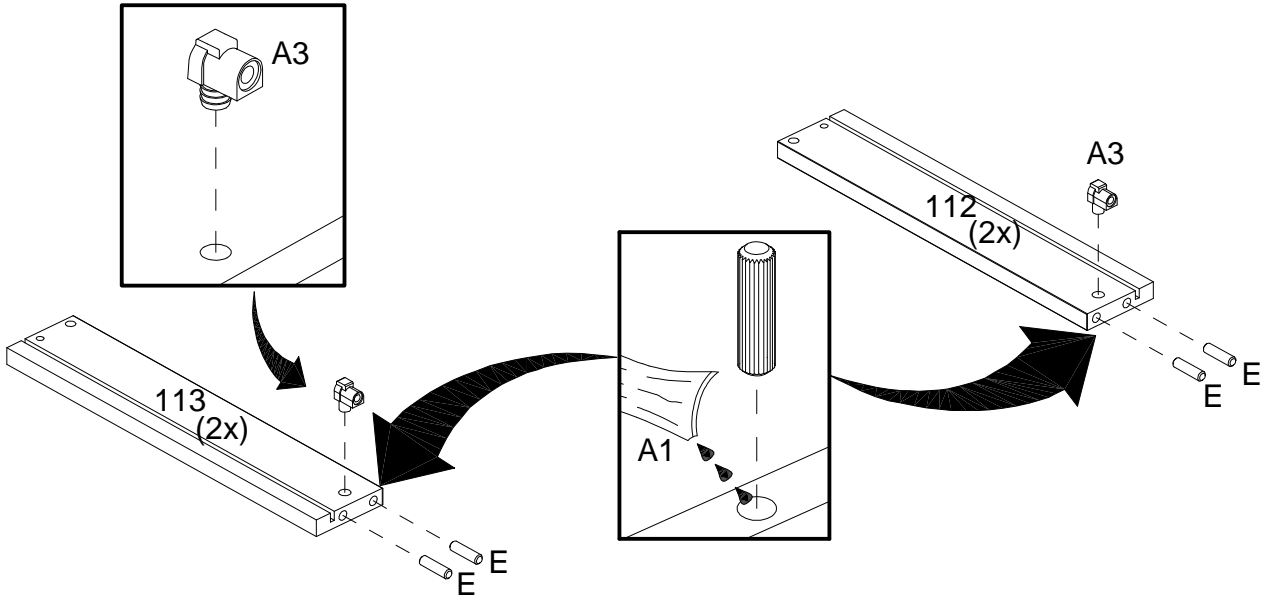

05

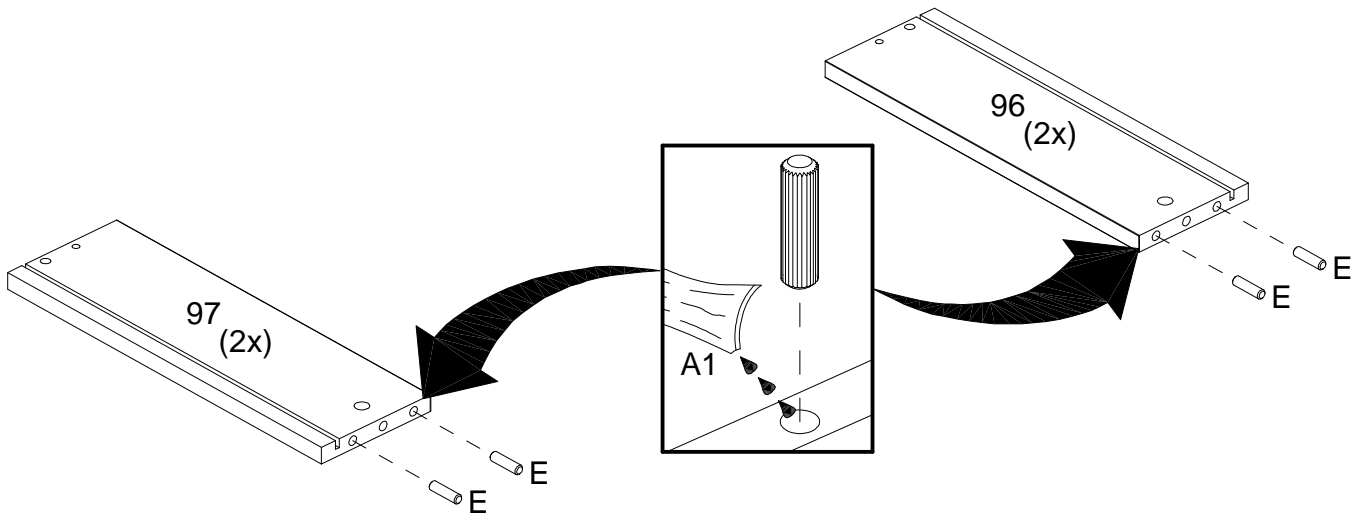

06

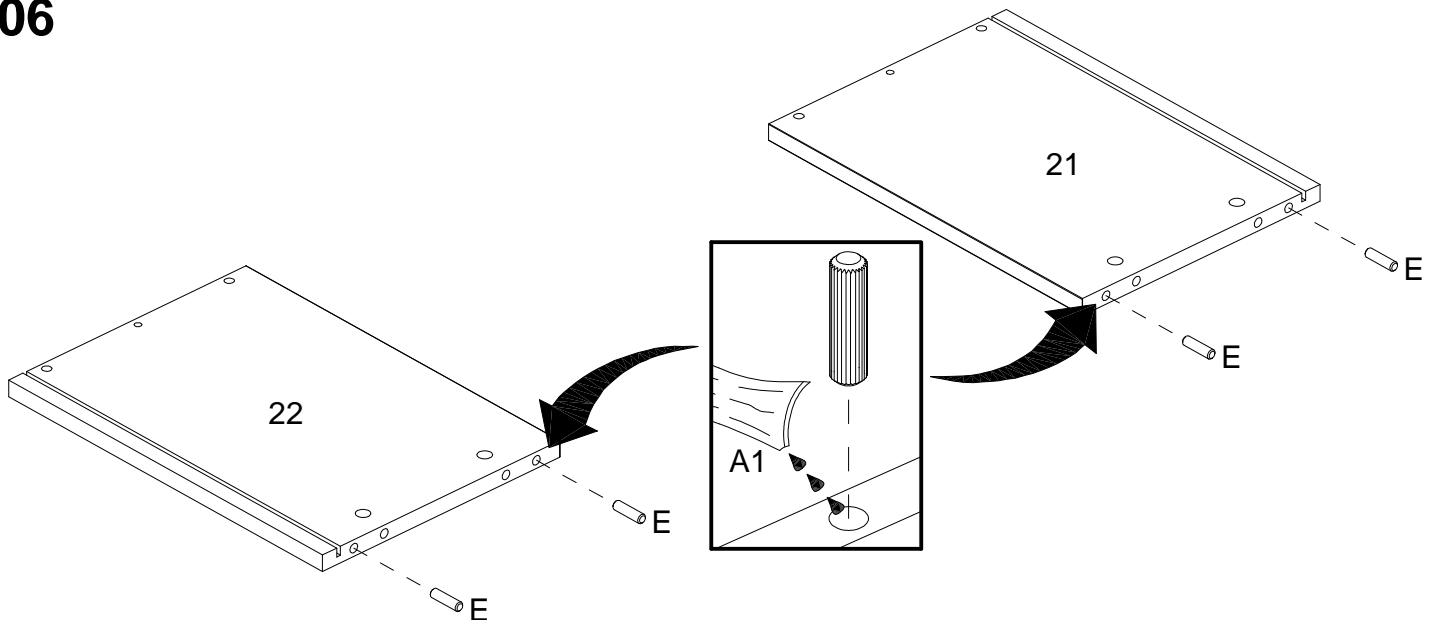

07

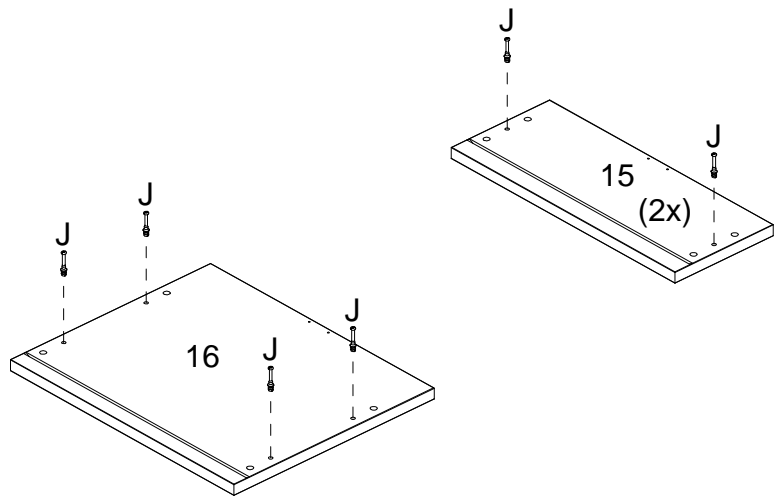
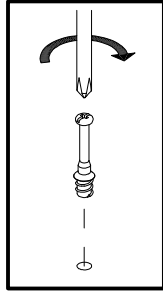

08

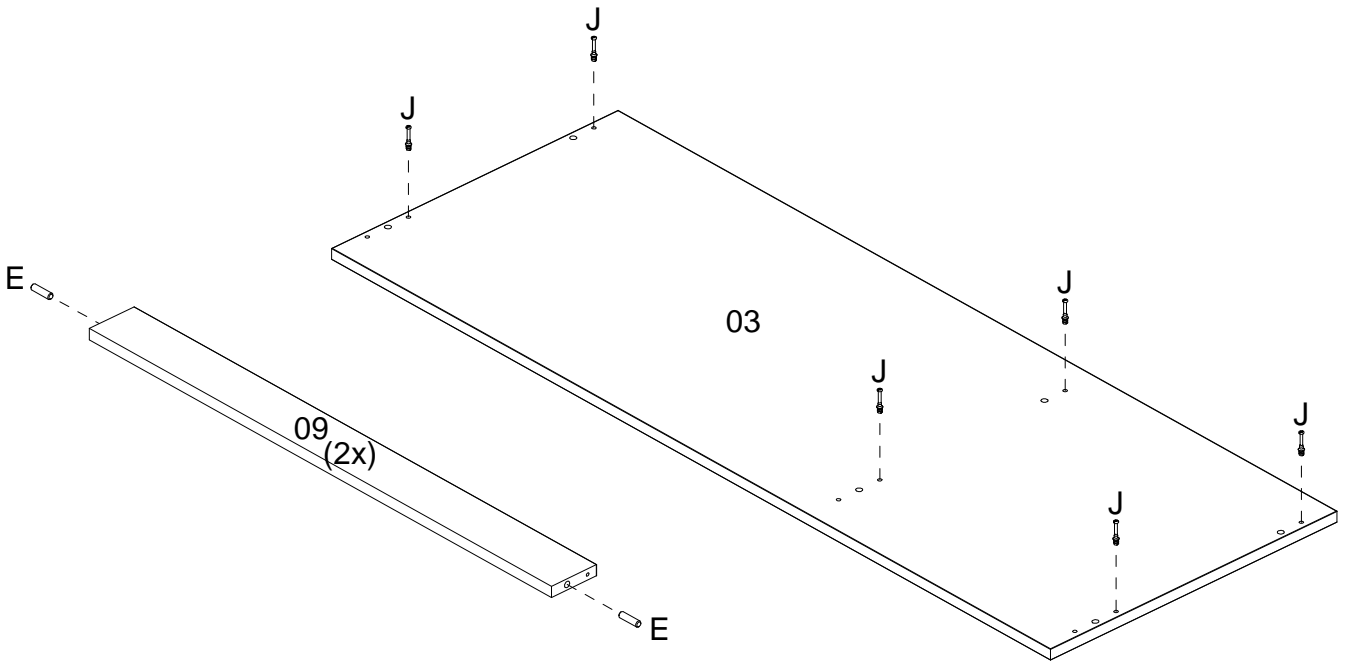

09

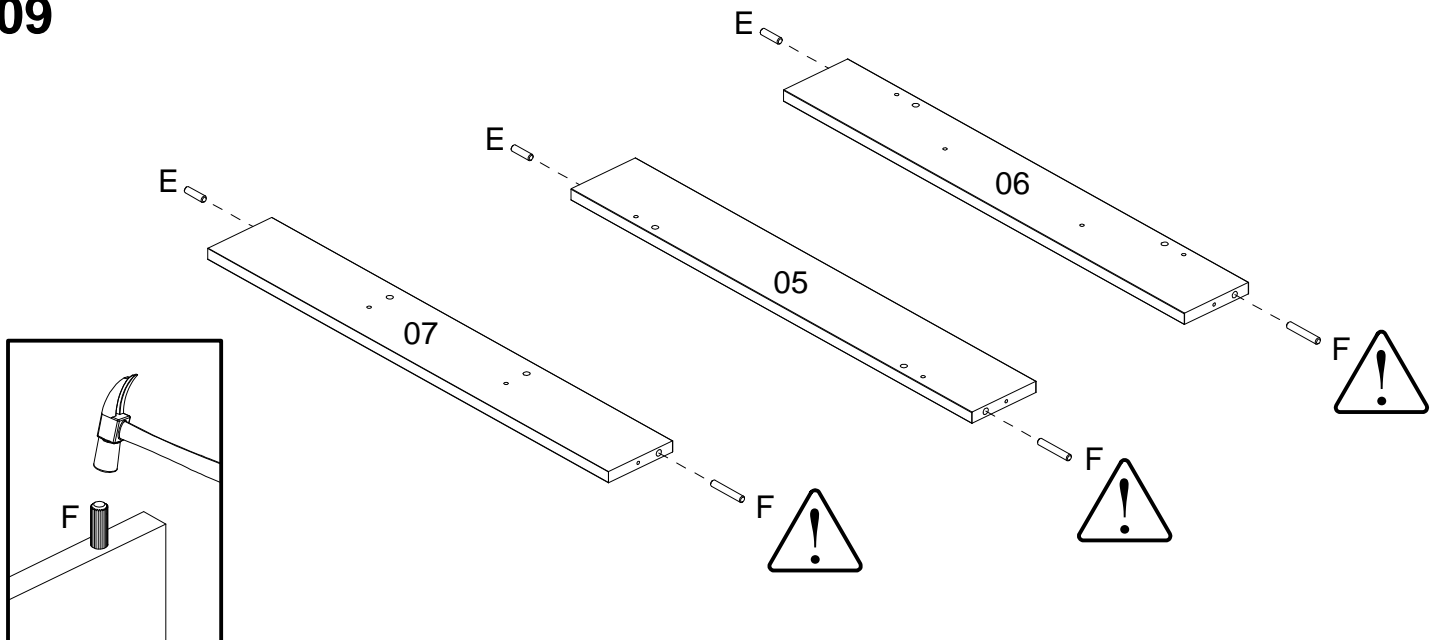

10

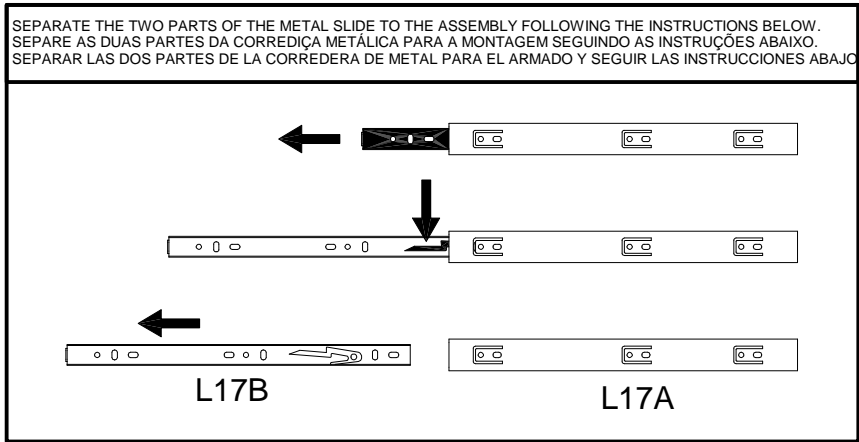

11

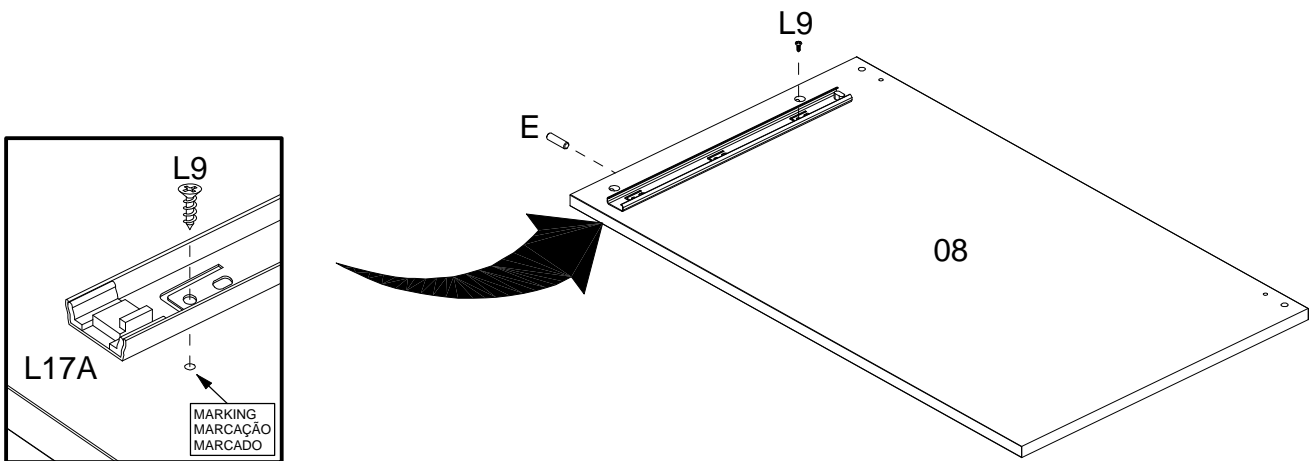

12

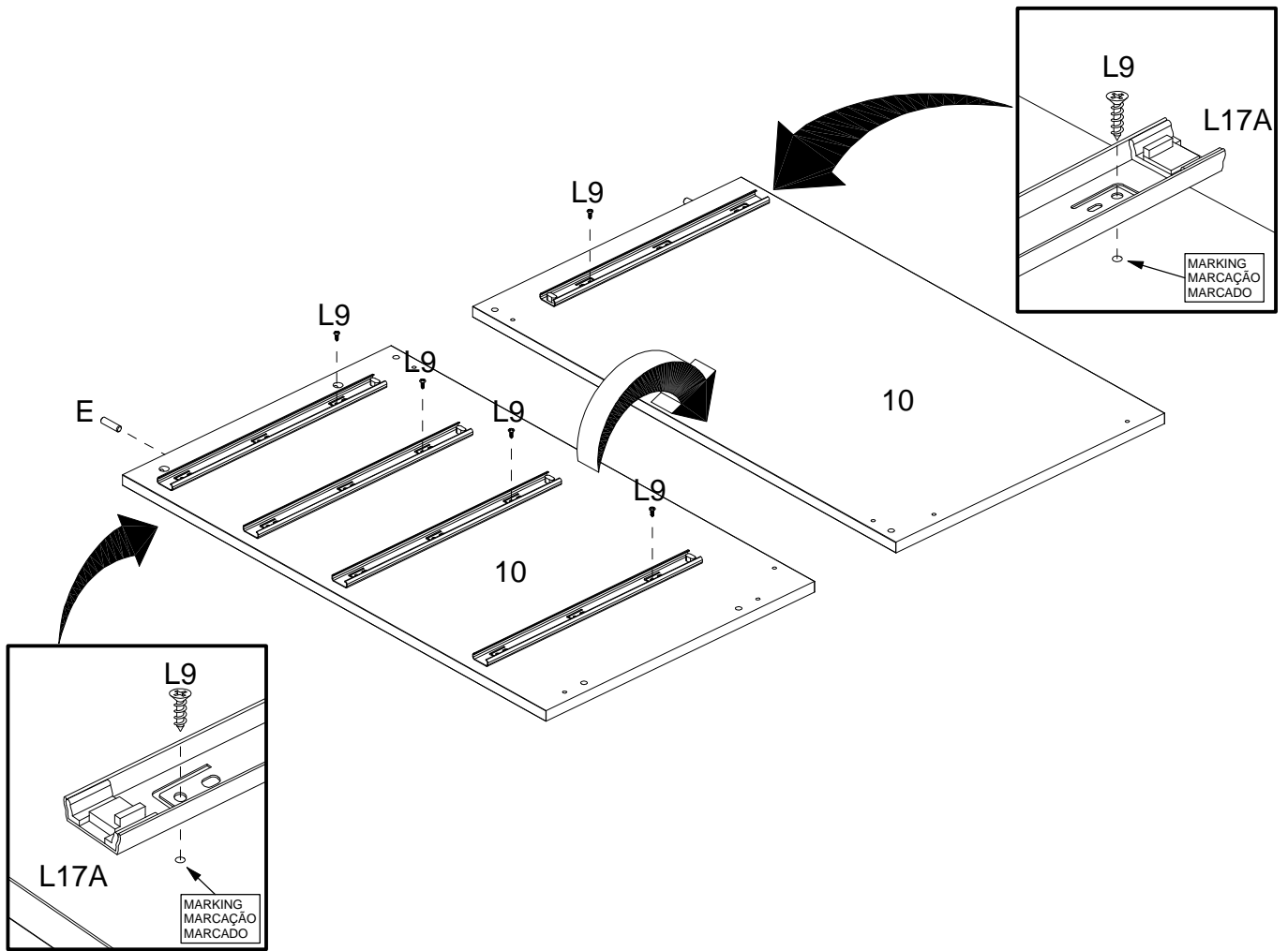

13

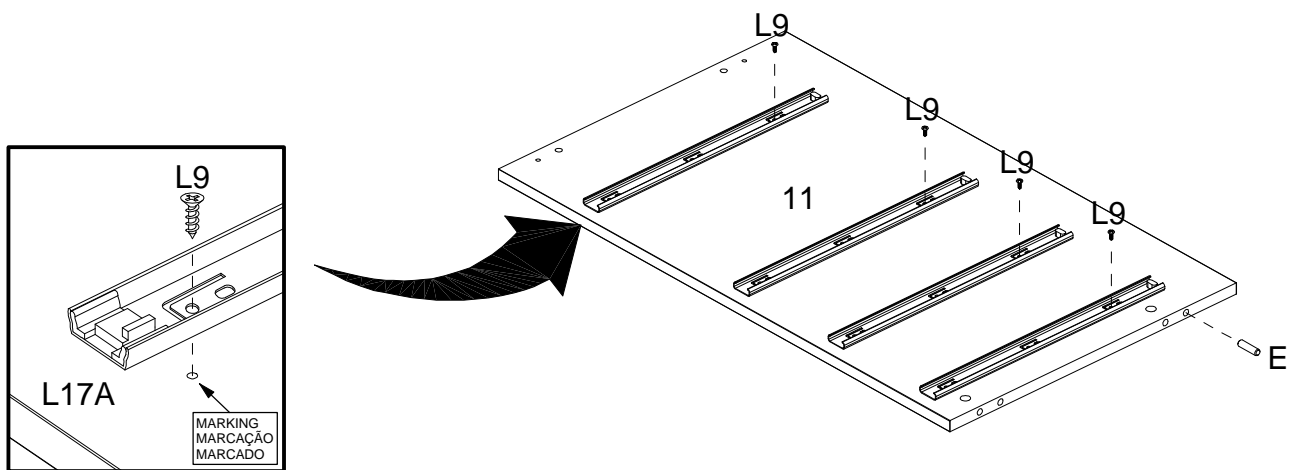

ASSEMBLY
MONTAGEM / ARMADO

14

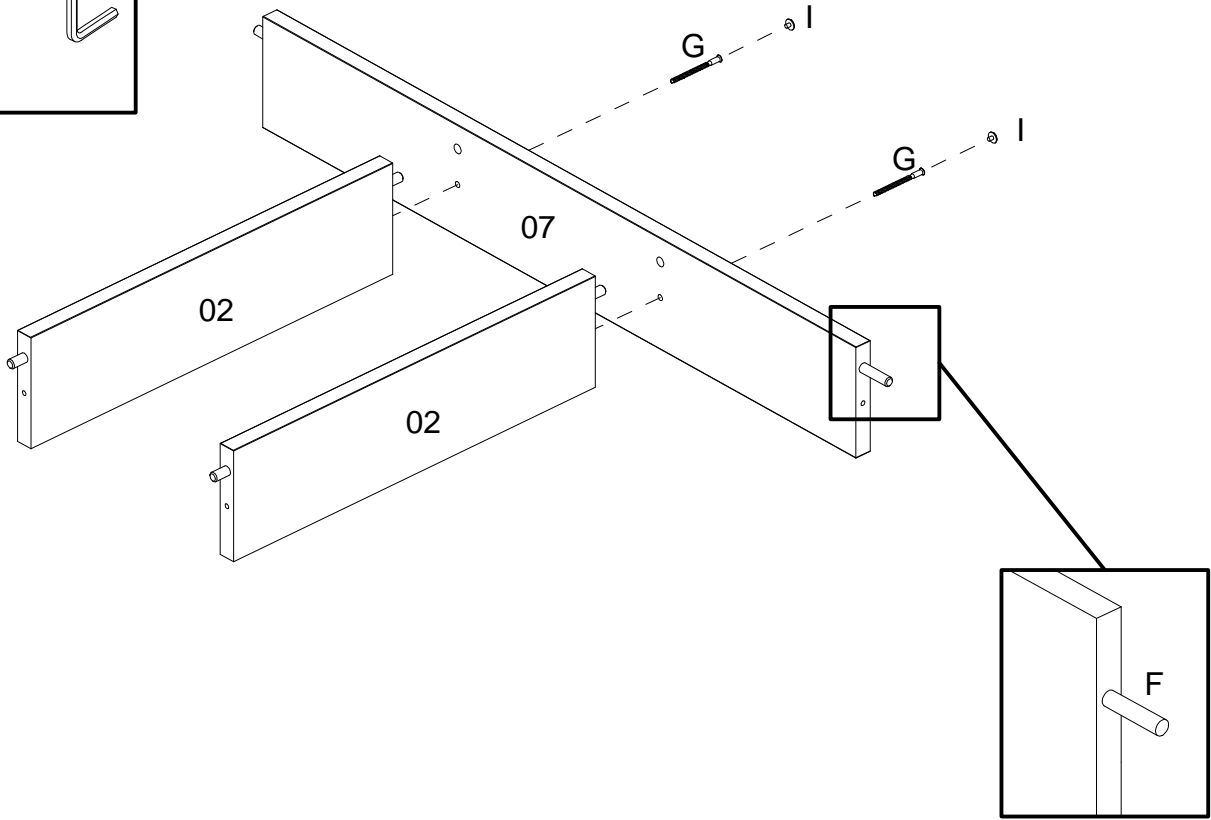
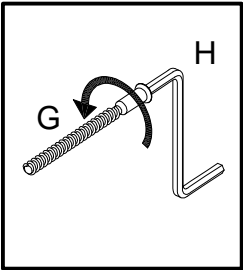

15

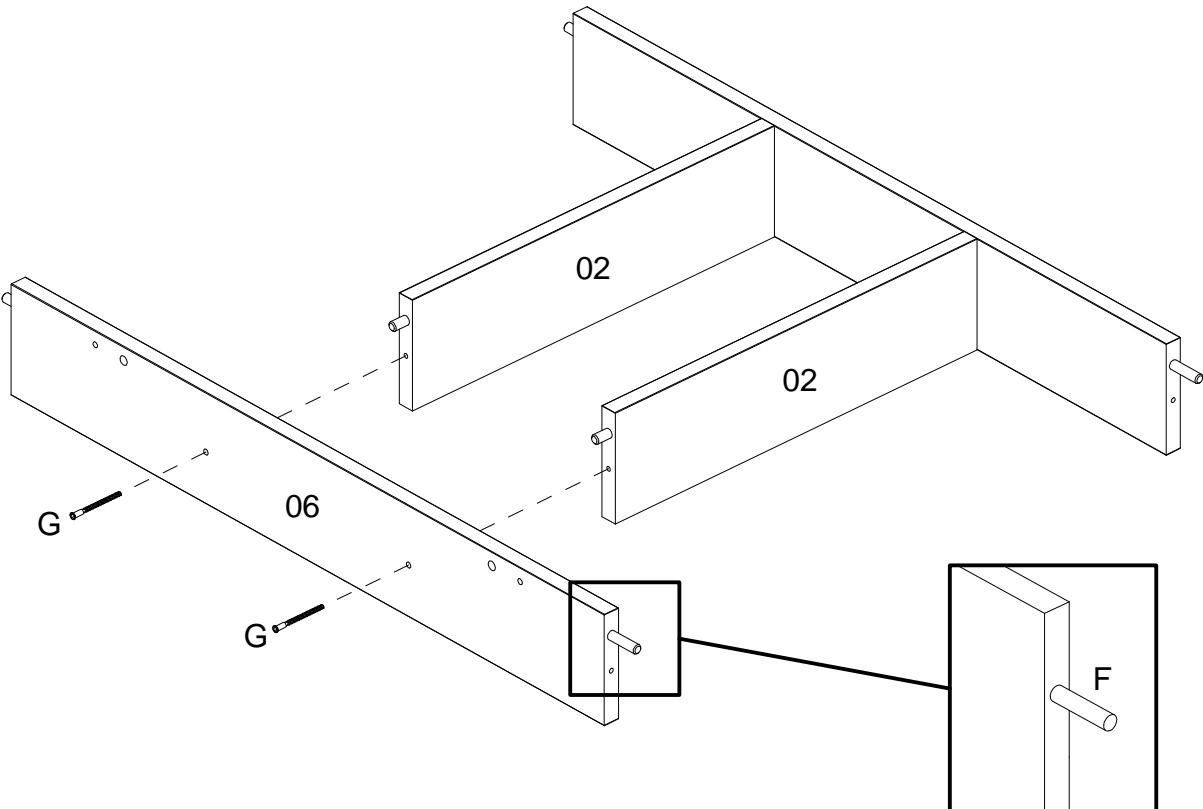

16

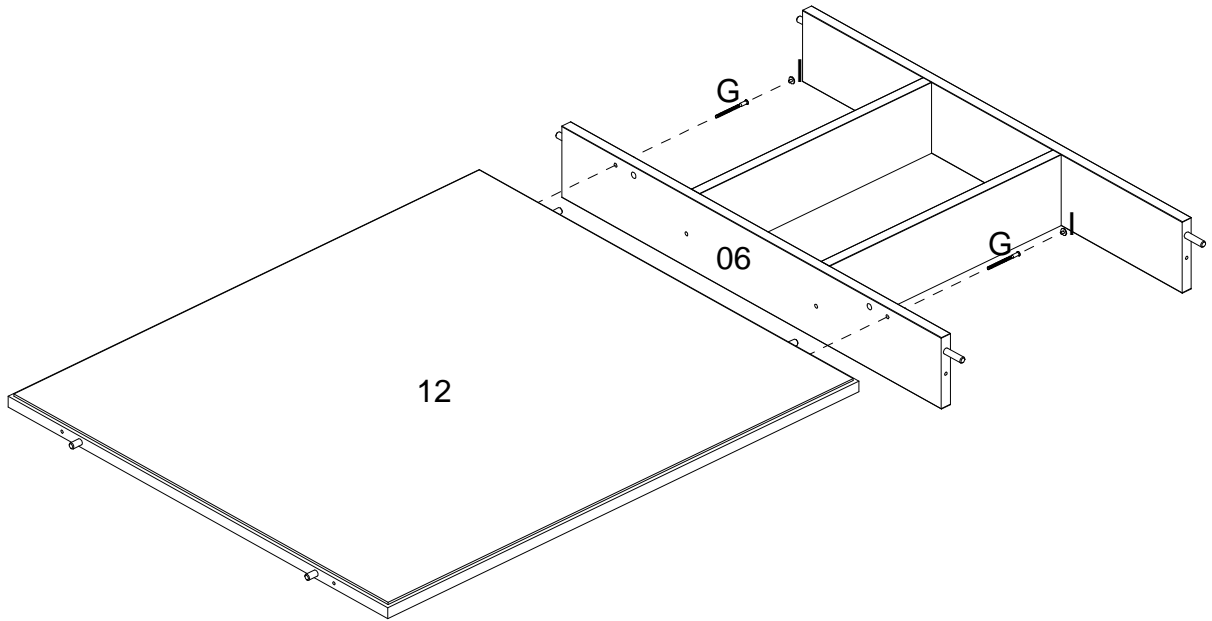

17

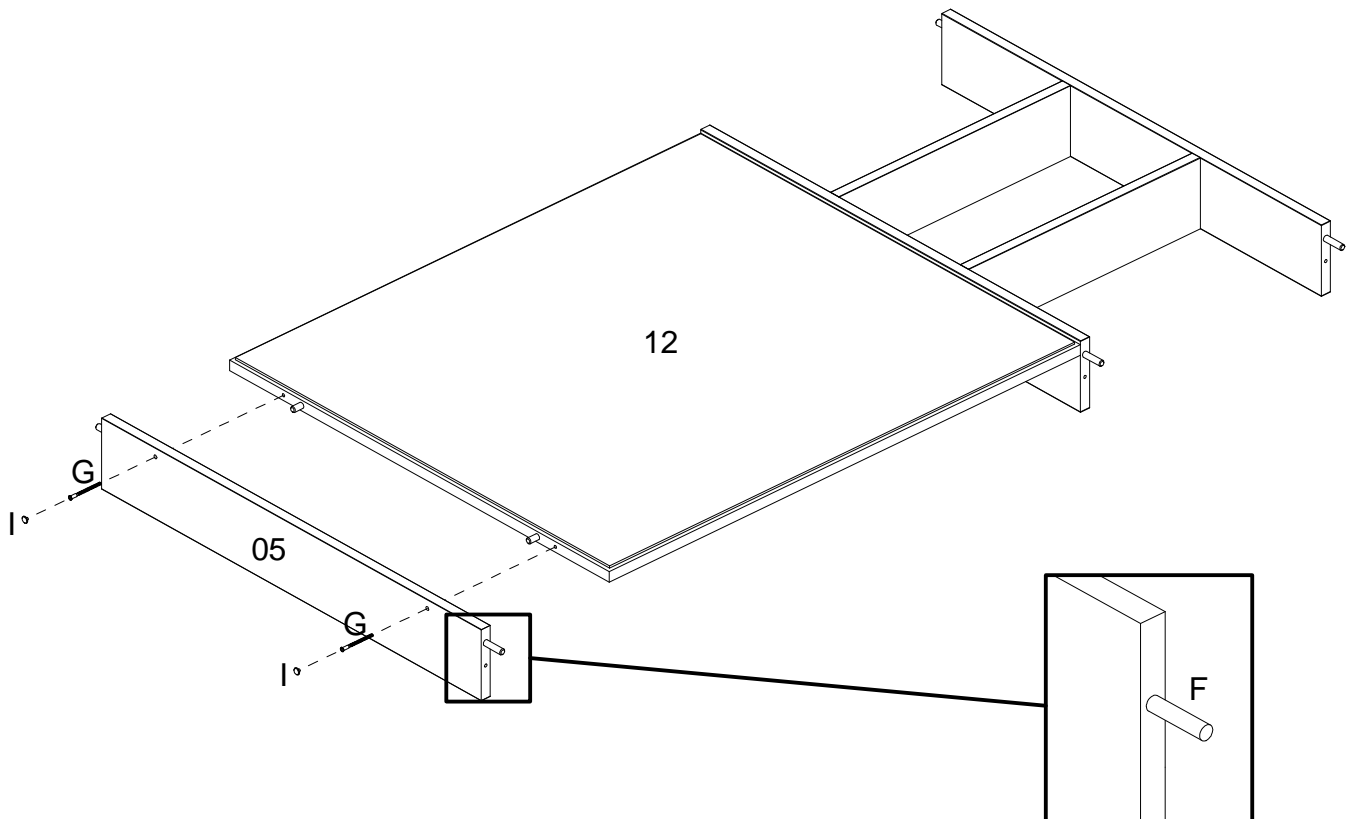

18

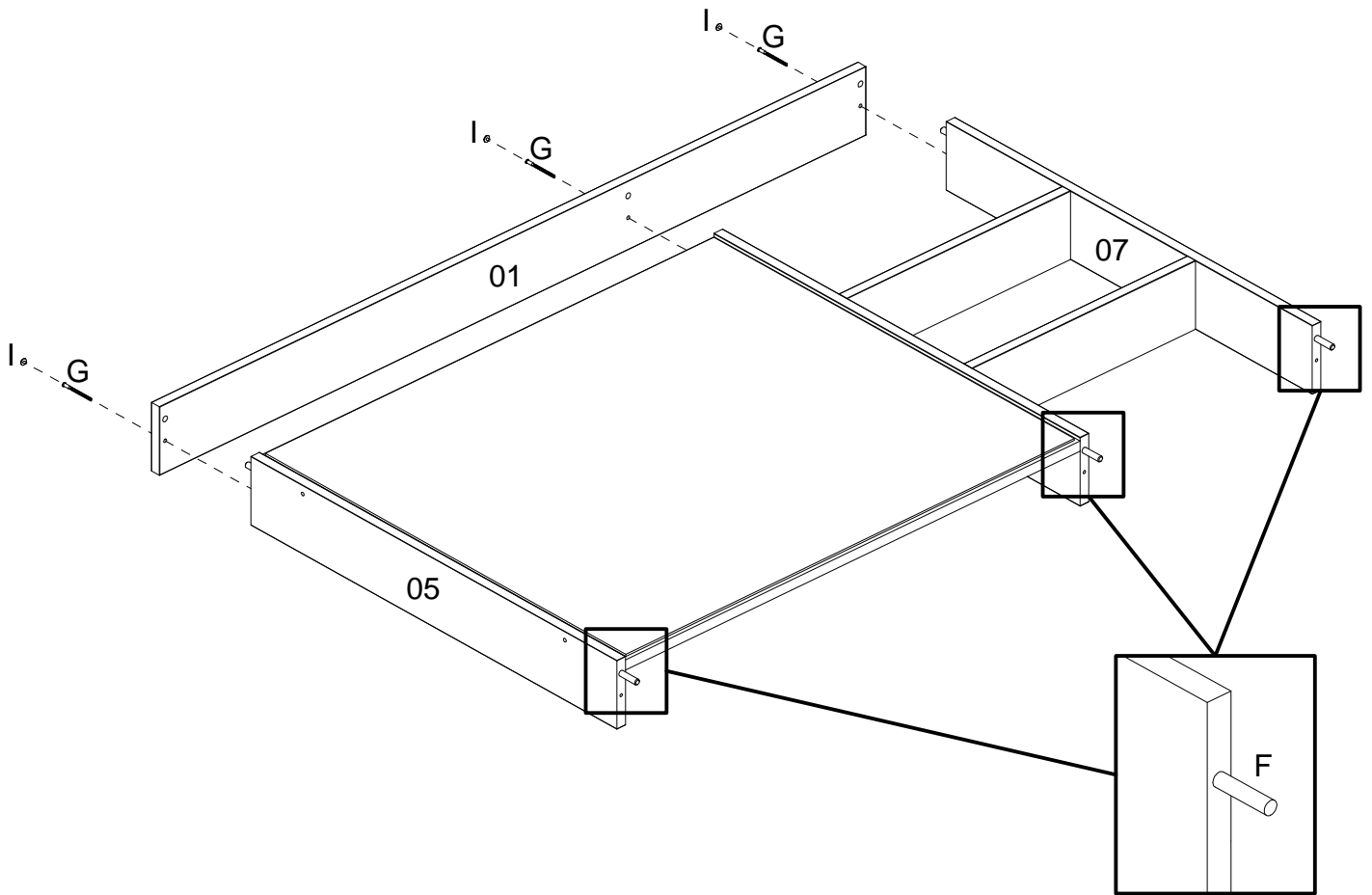

19

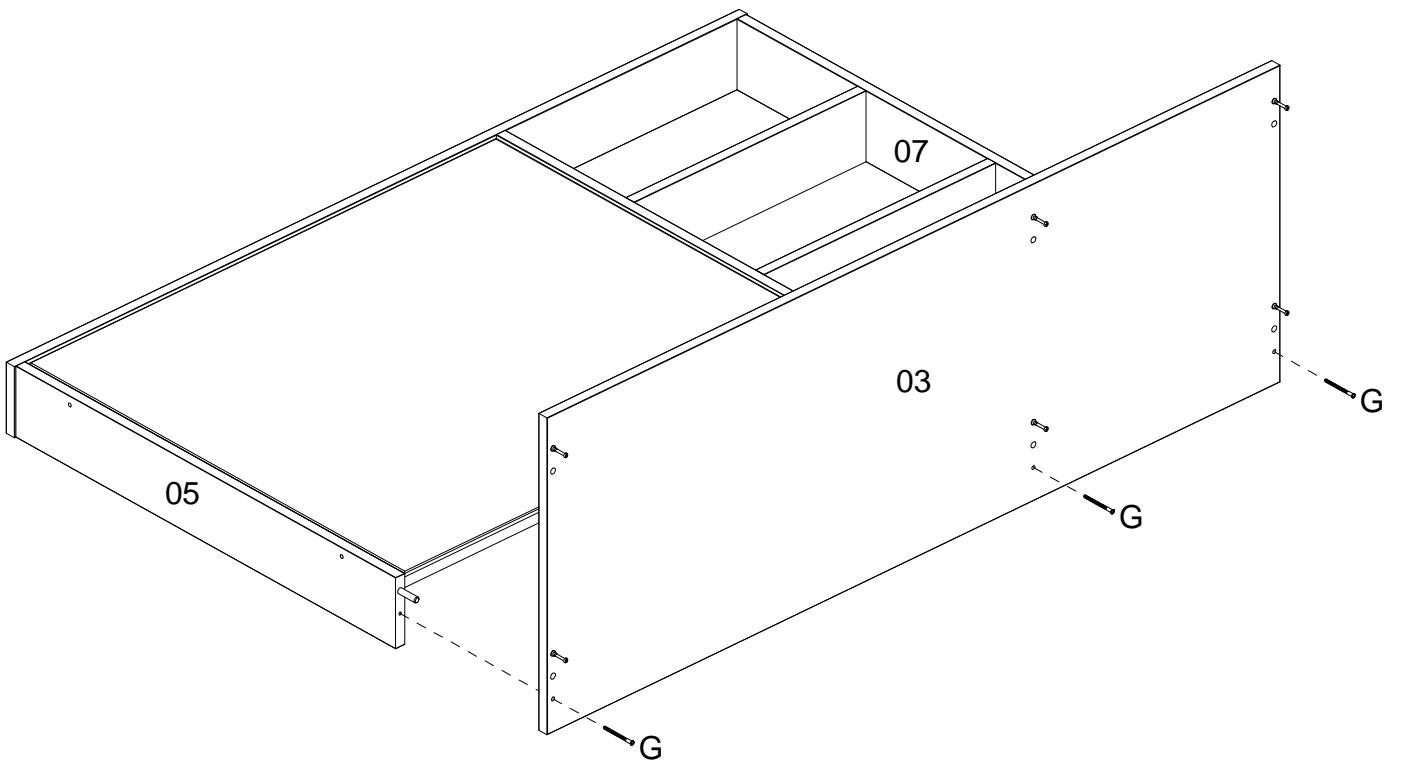

20

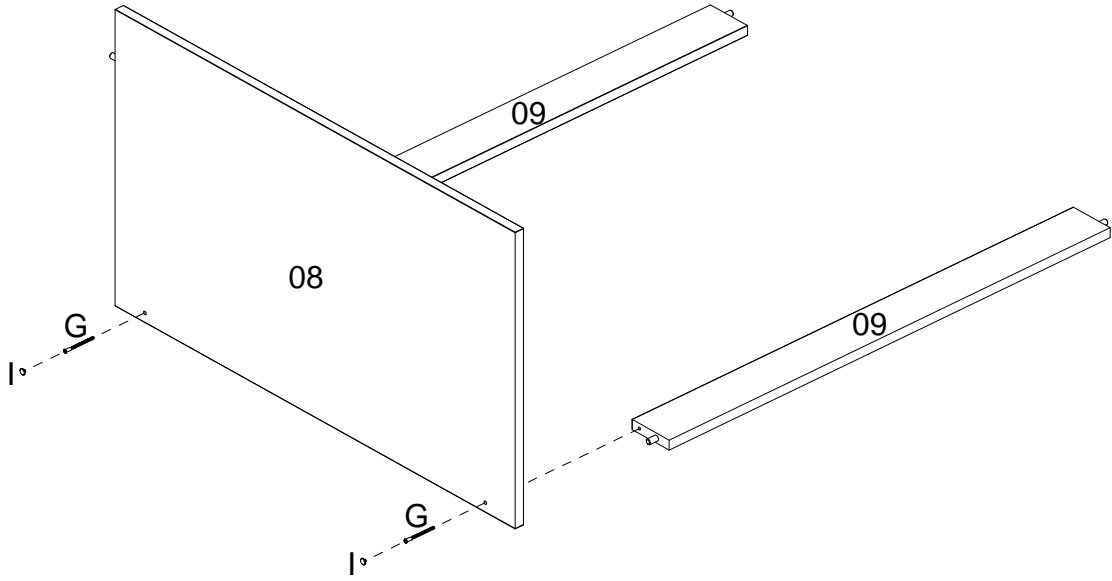

21

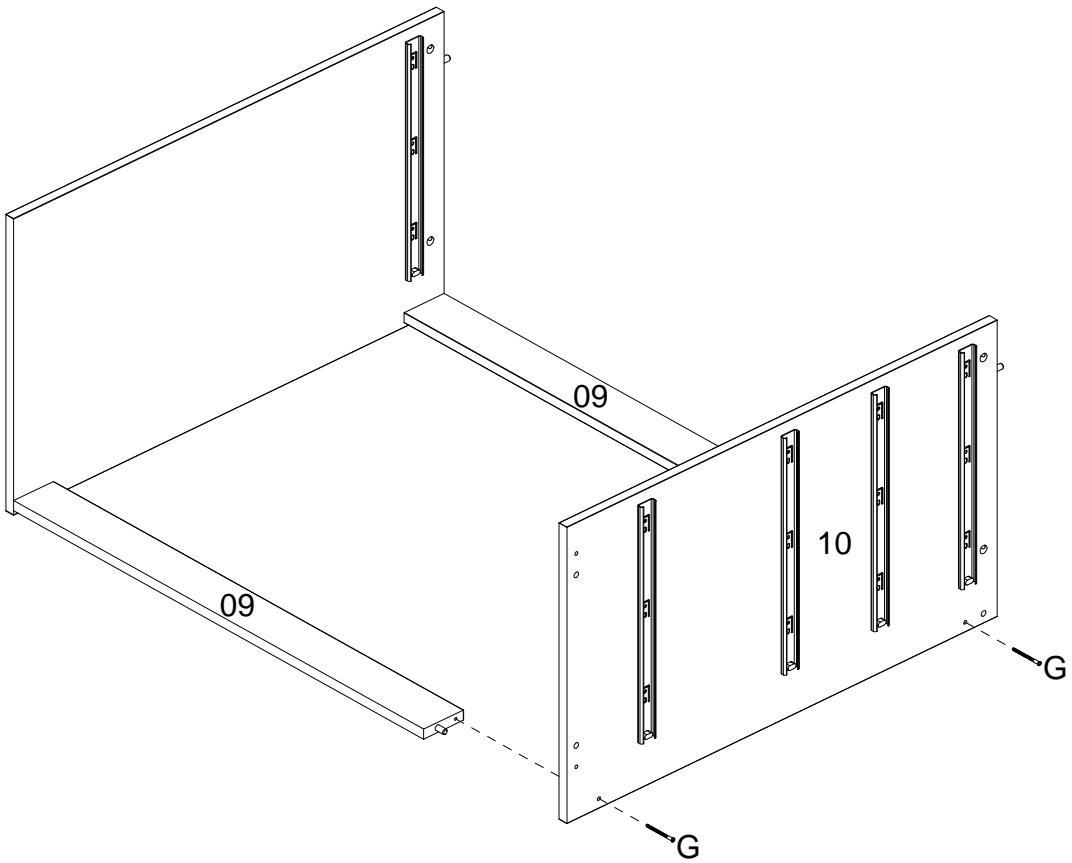

22

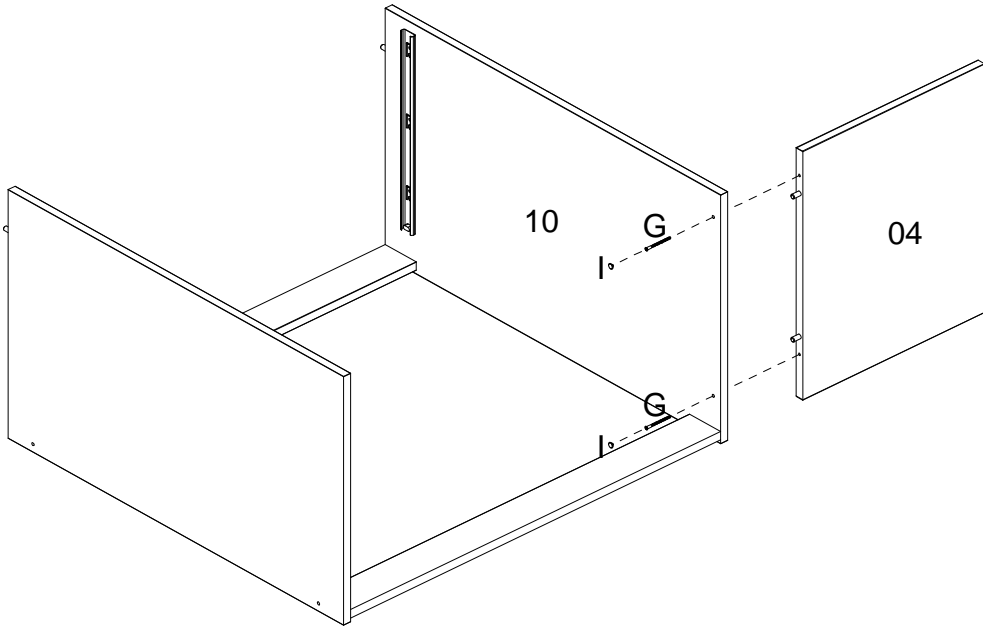

23

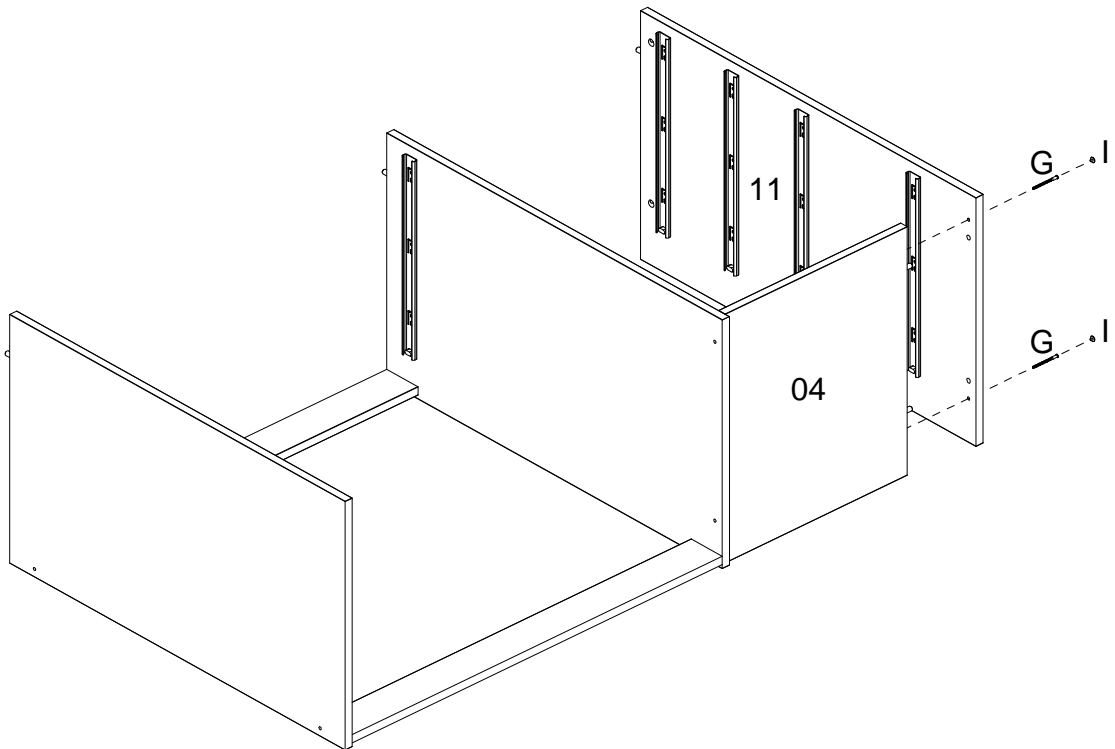

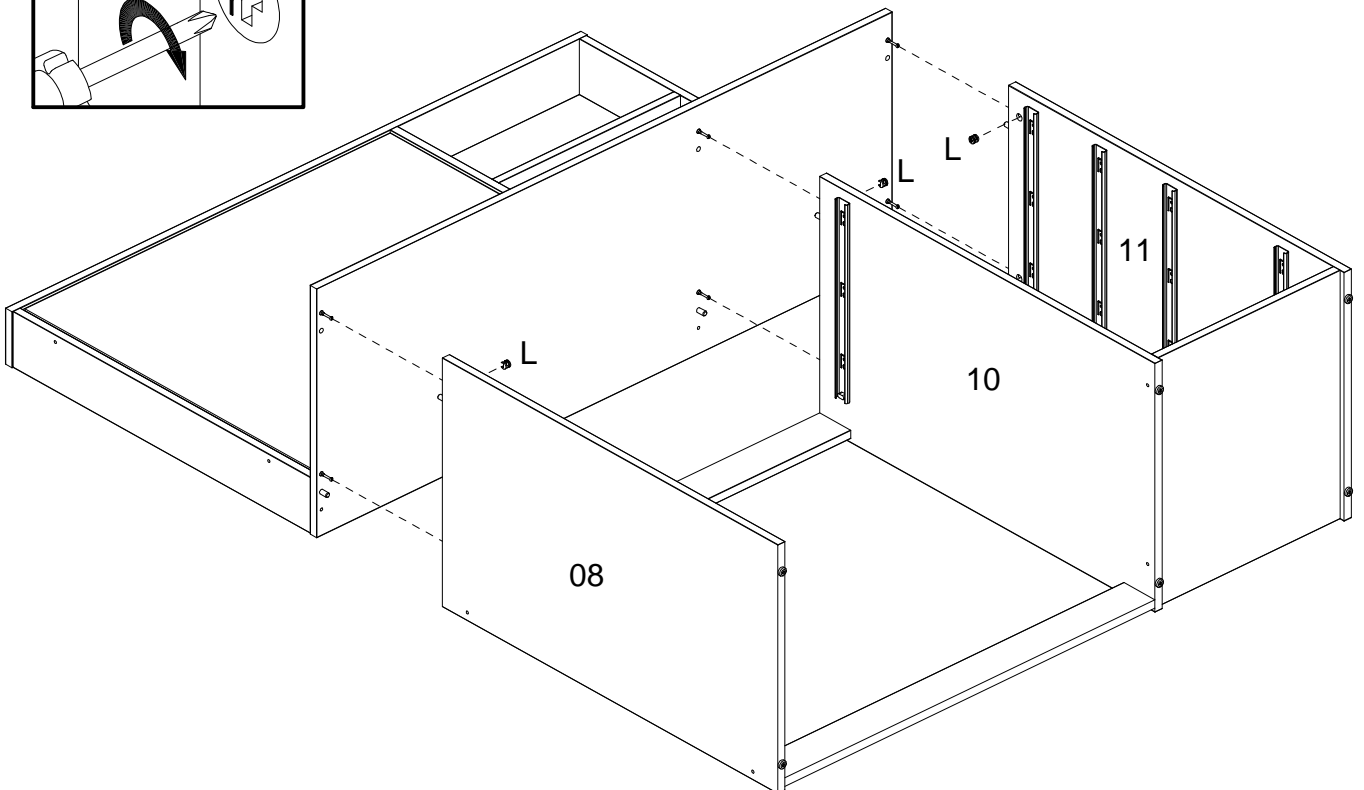
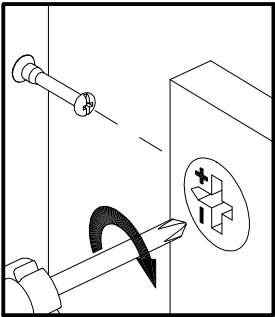
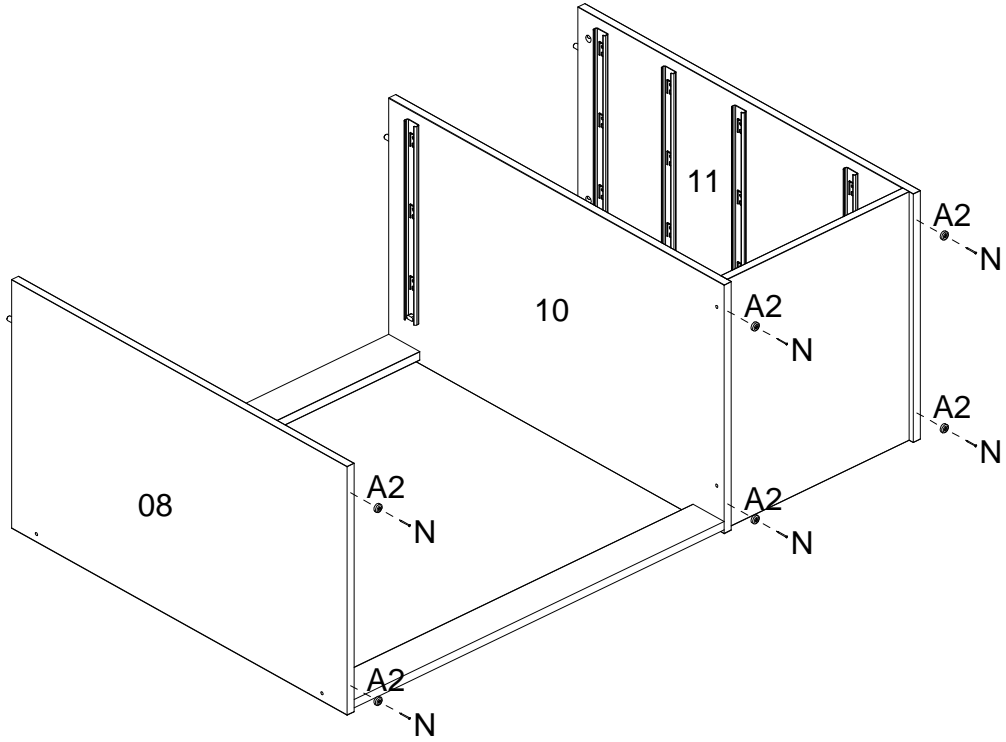

26

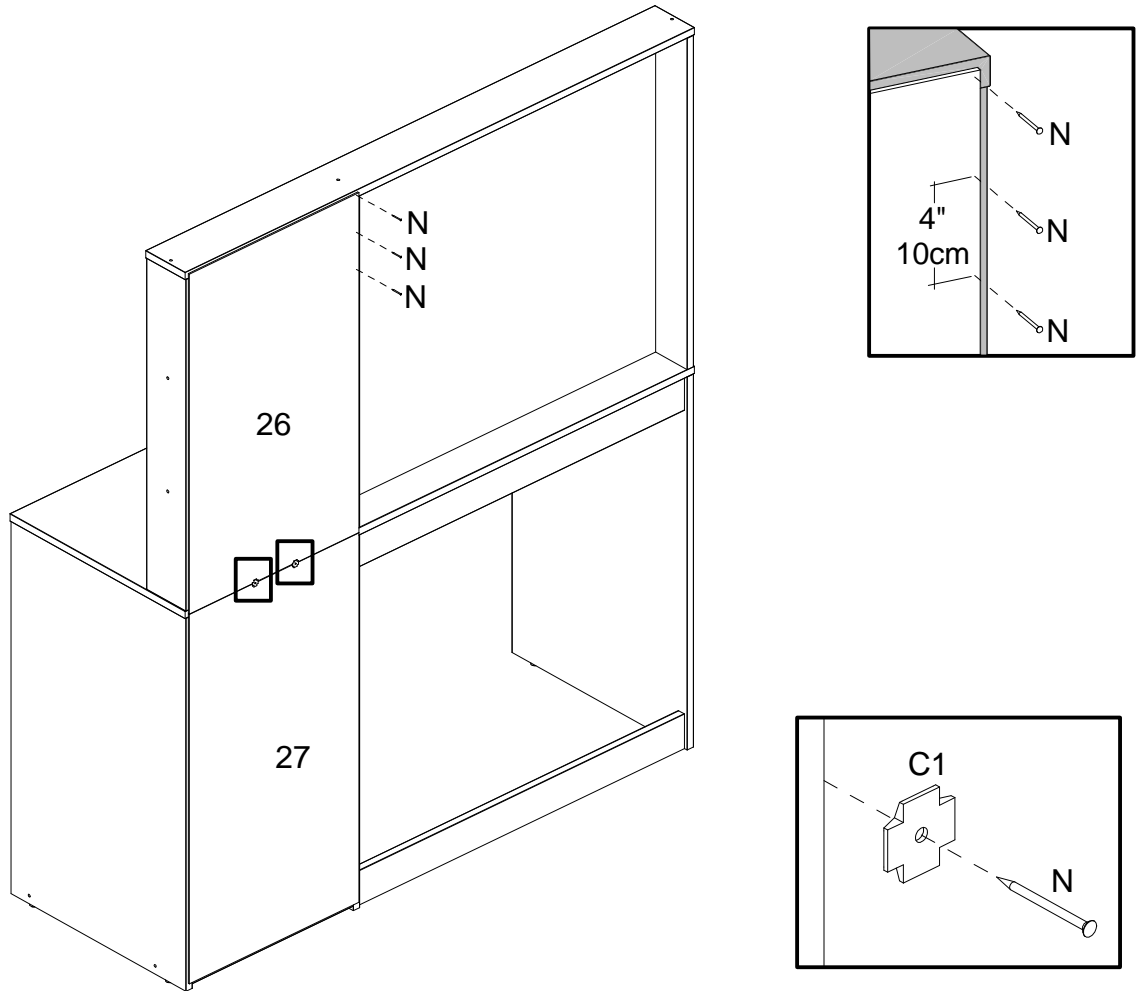

27

TO AVOID ANY INJURY THE FURNITURE MUST BE FIXED ON THE WALL. THANKS.
PARA EVITAR QUALQUER ACIDENTE, É OBRIGATÓRIO FIXAR O MÓVEL NA PAREDE. OBRIGADO!
PARA EVITAR CUALQUIER ACCIDENTE ES OBLIGATORIO ANCLAR EL MUEBLE EN LA PARED. GRACIAS.

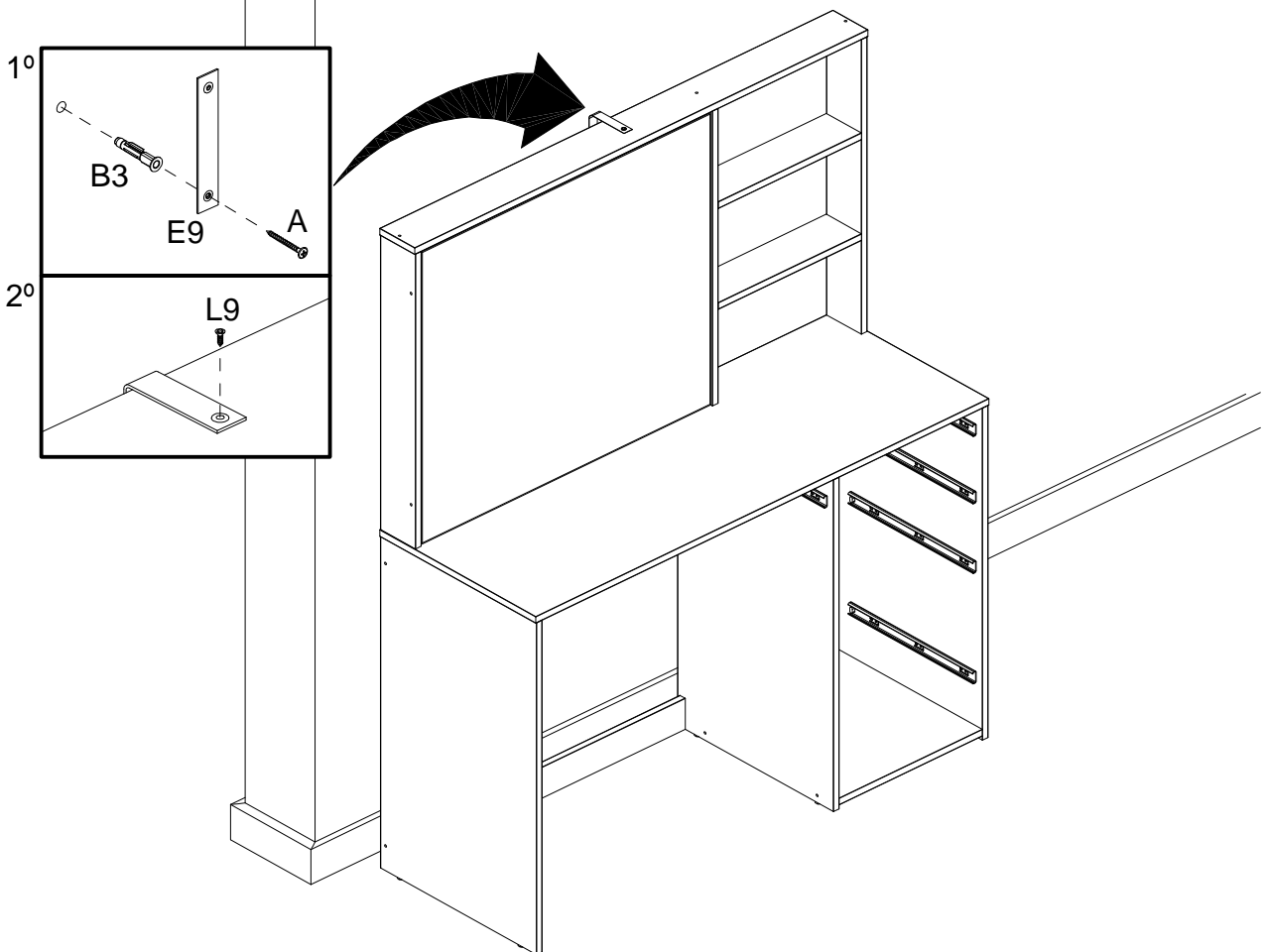

28

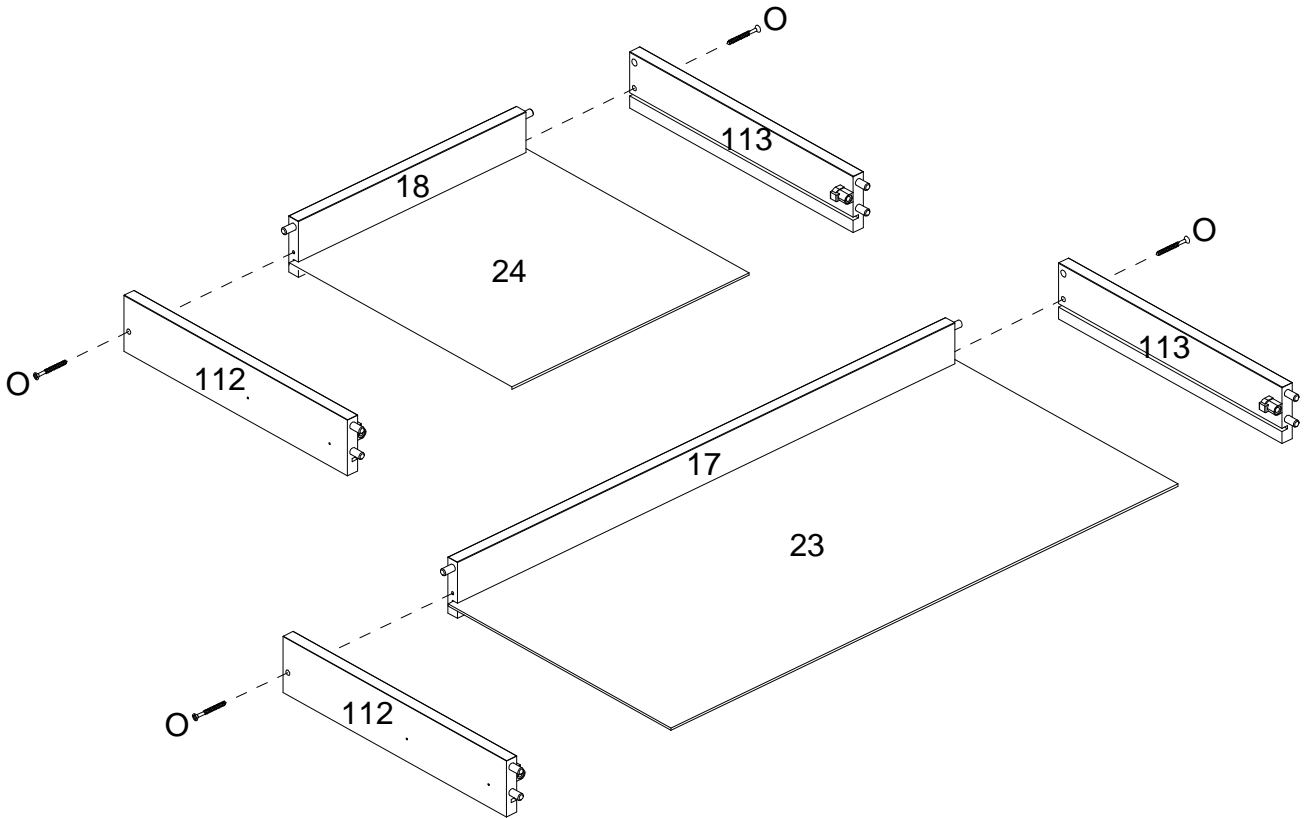

29

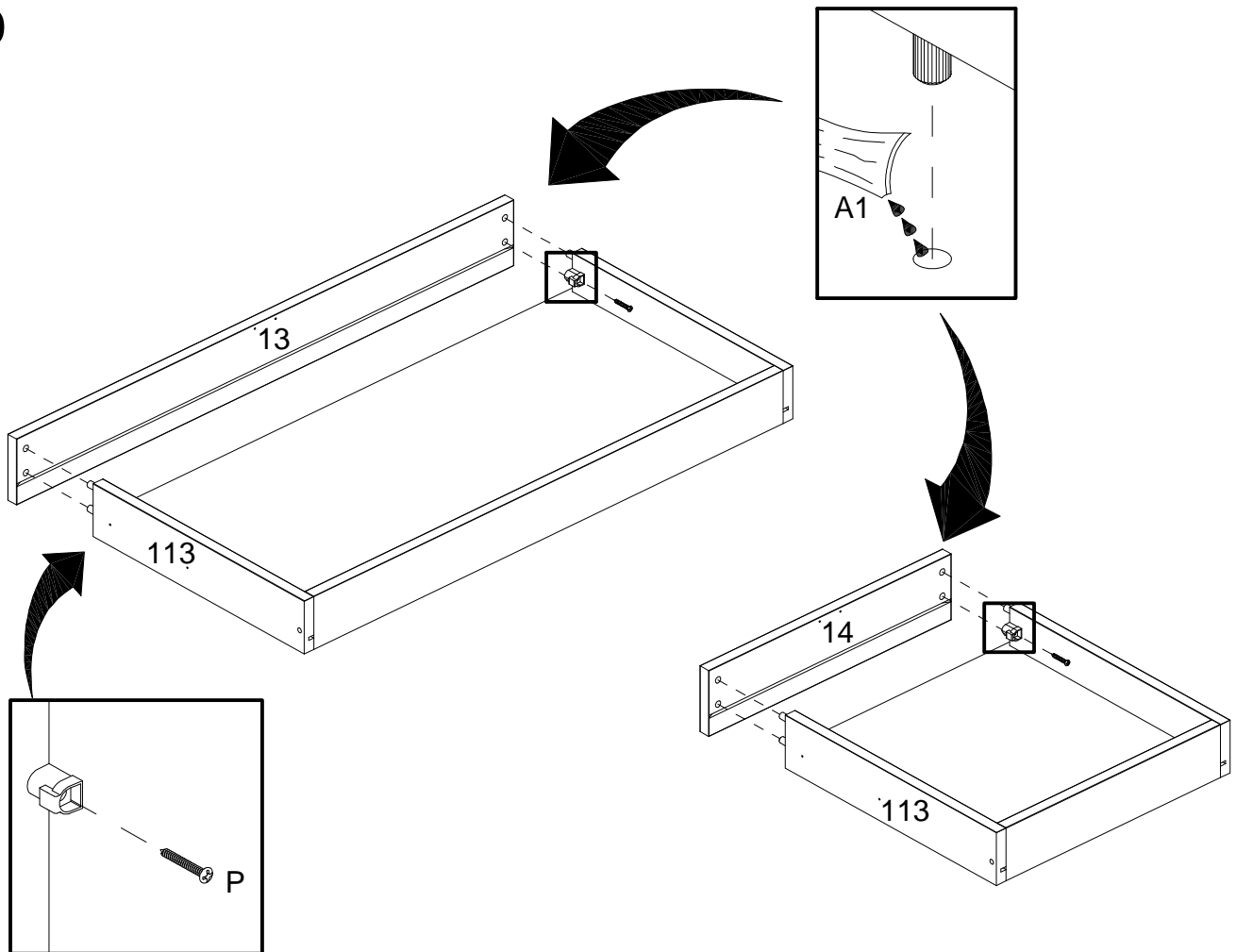

30

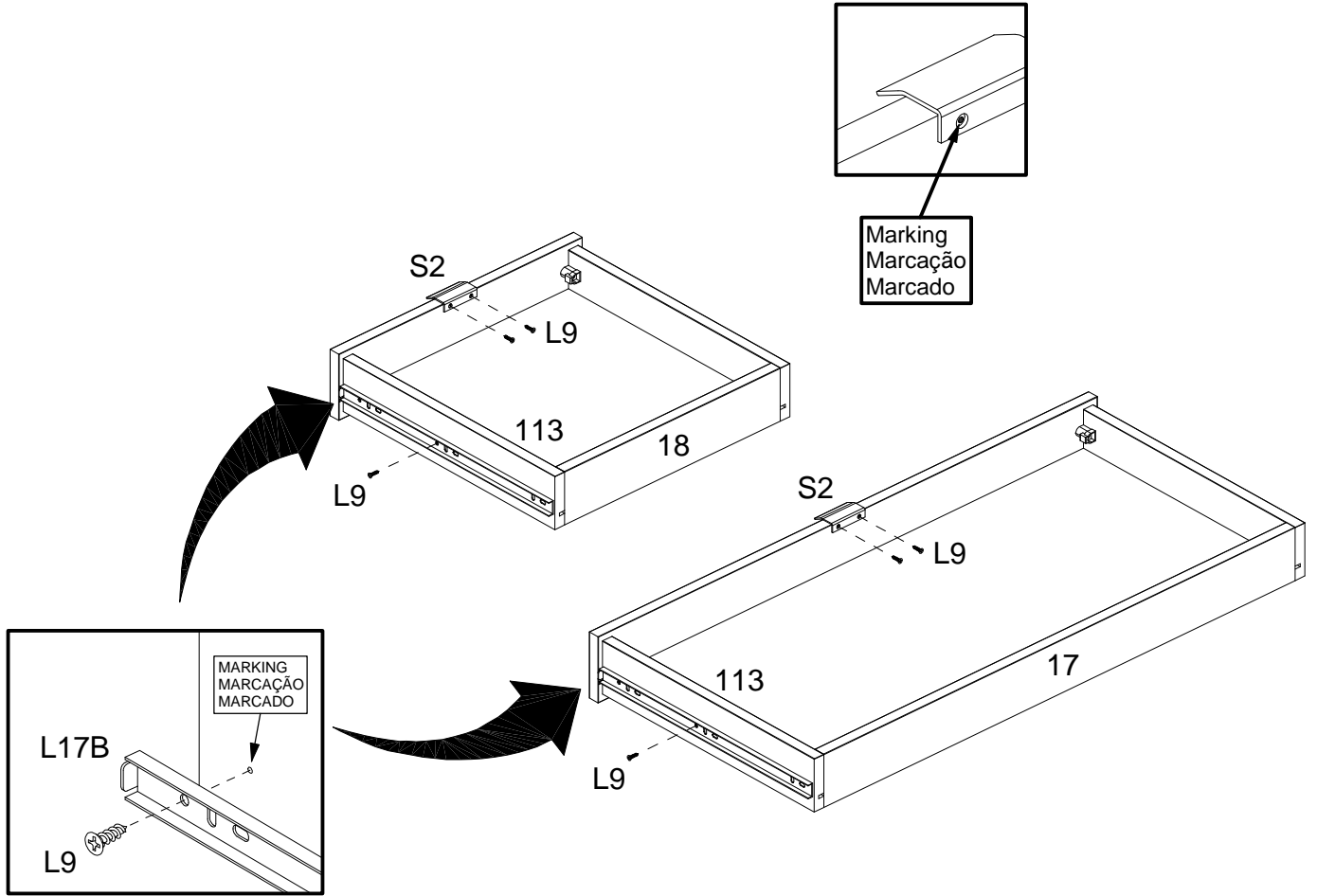

31

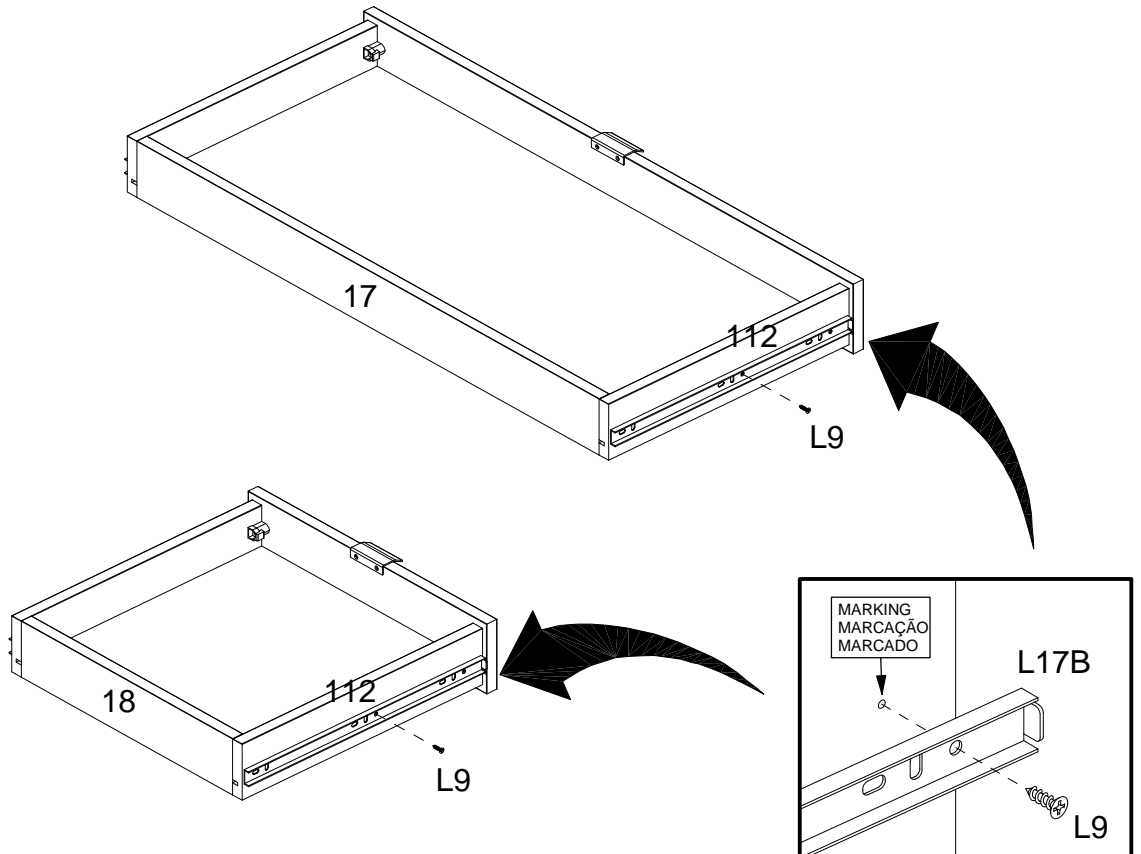

32

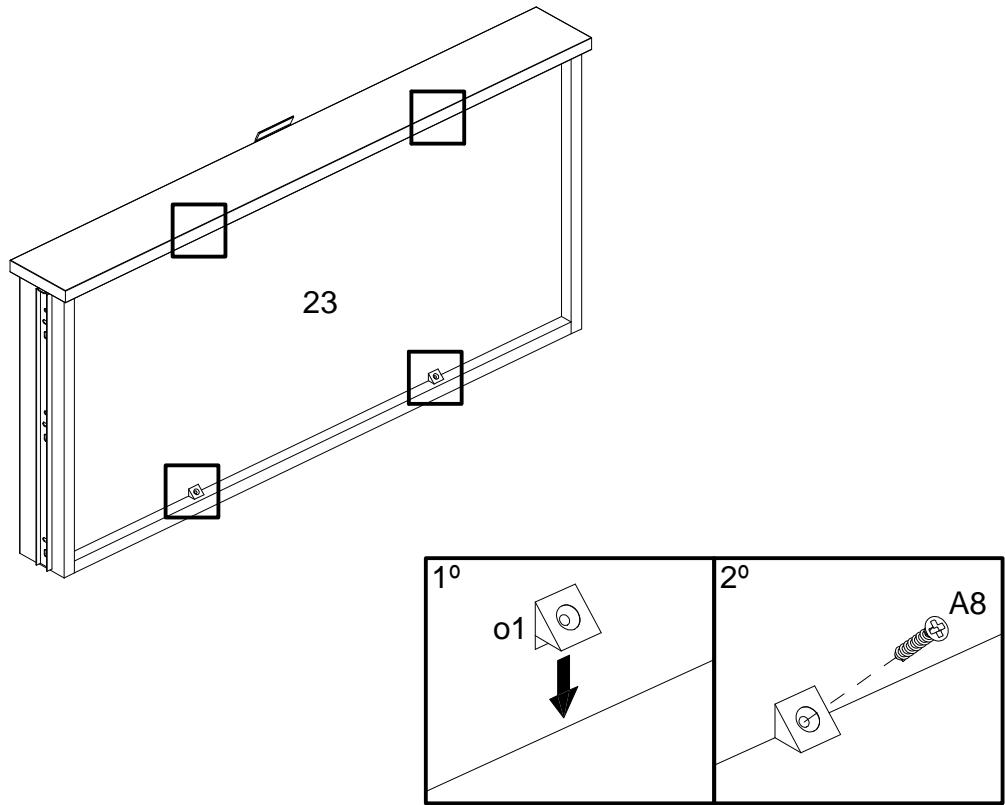

33

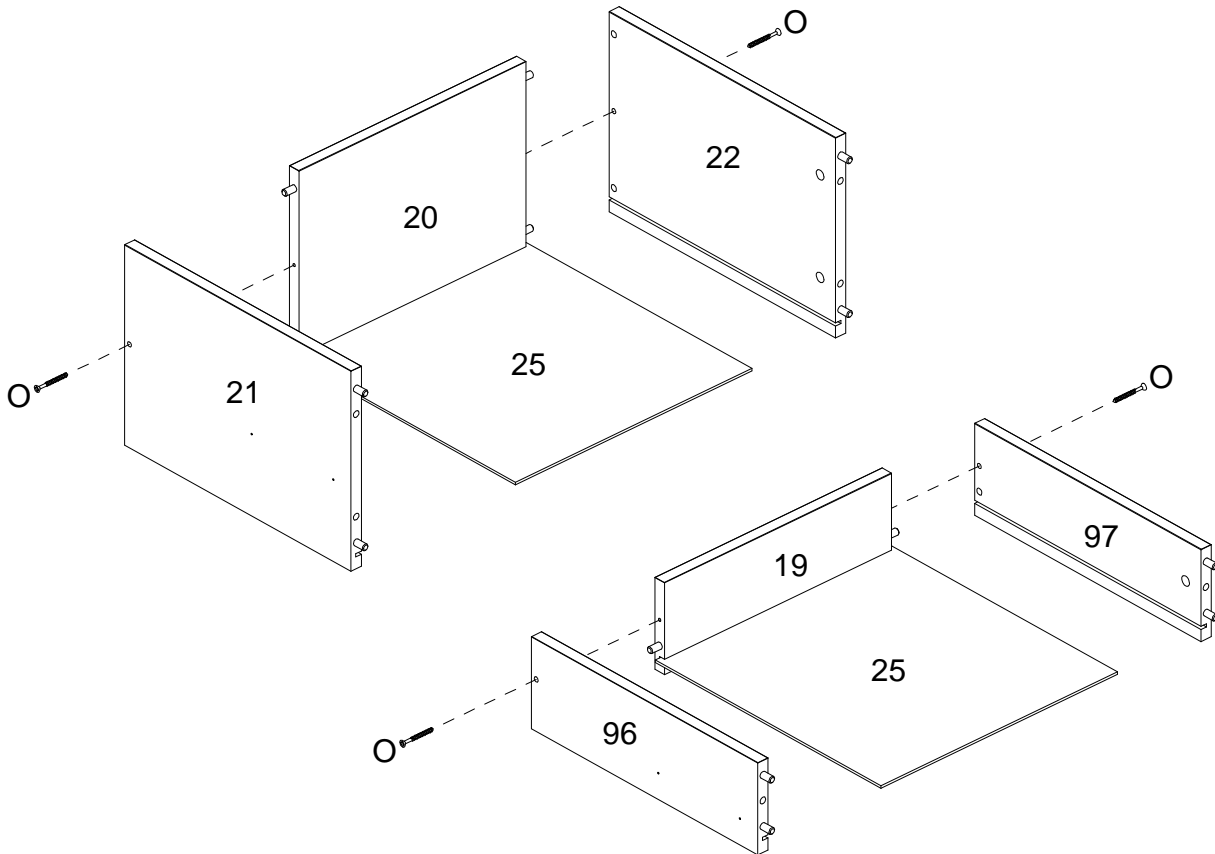

34

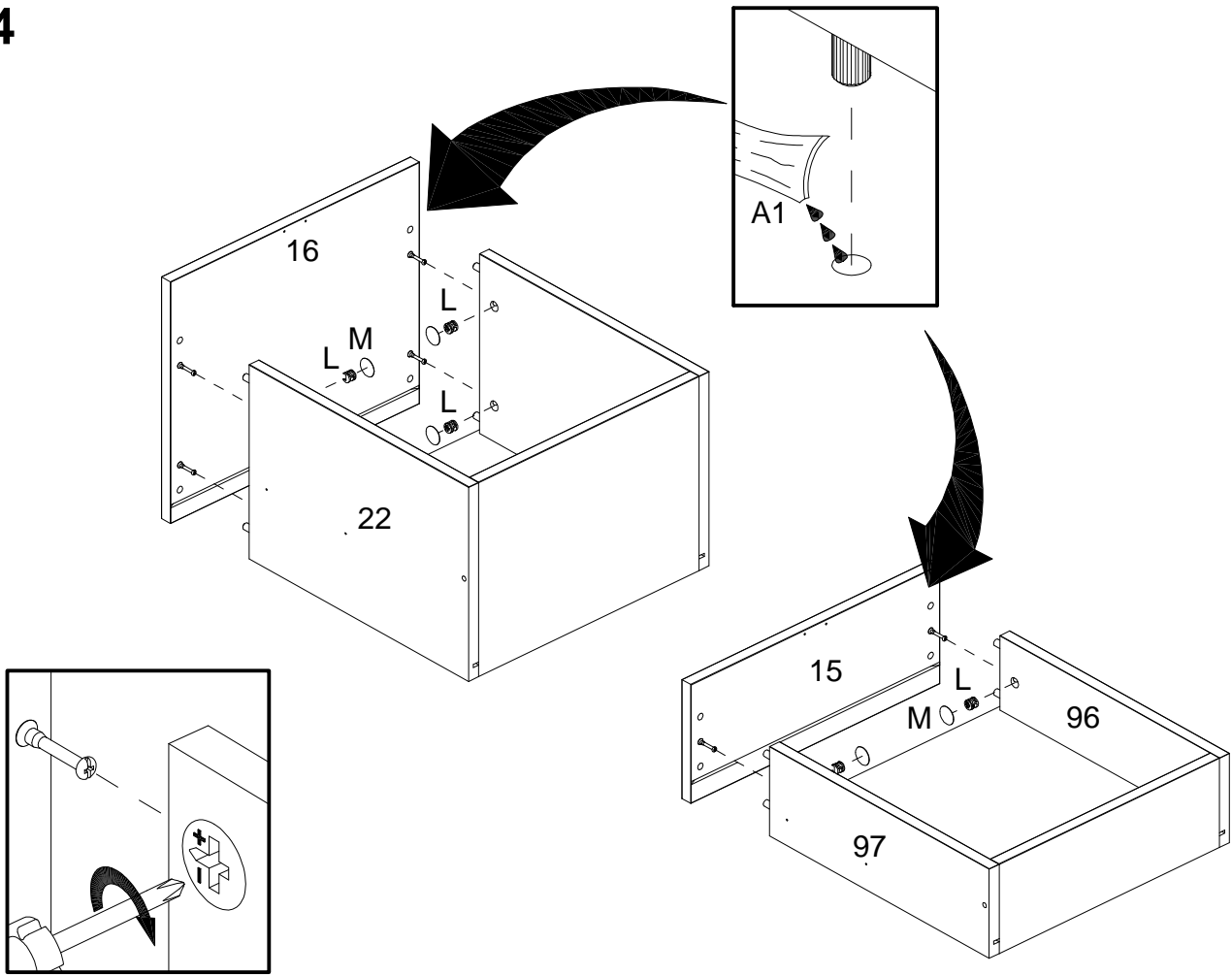

35

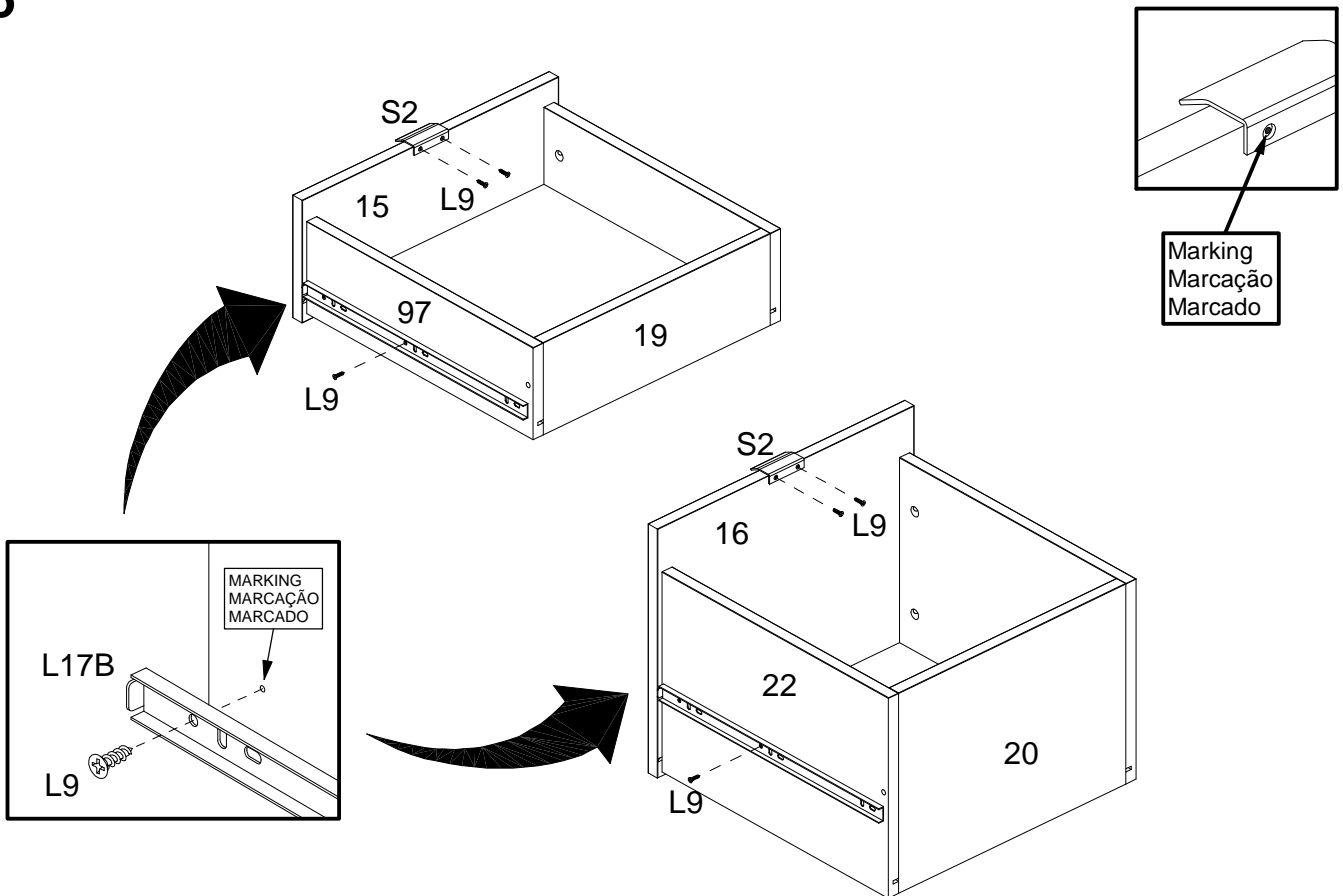

36

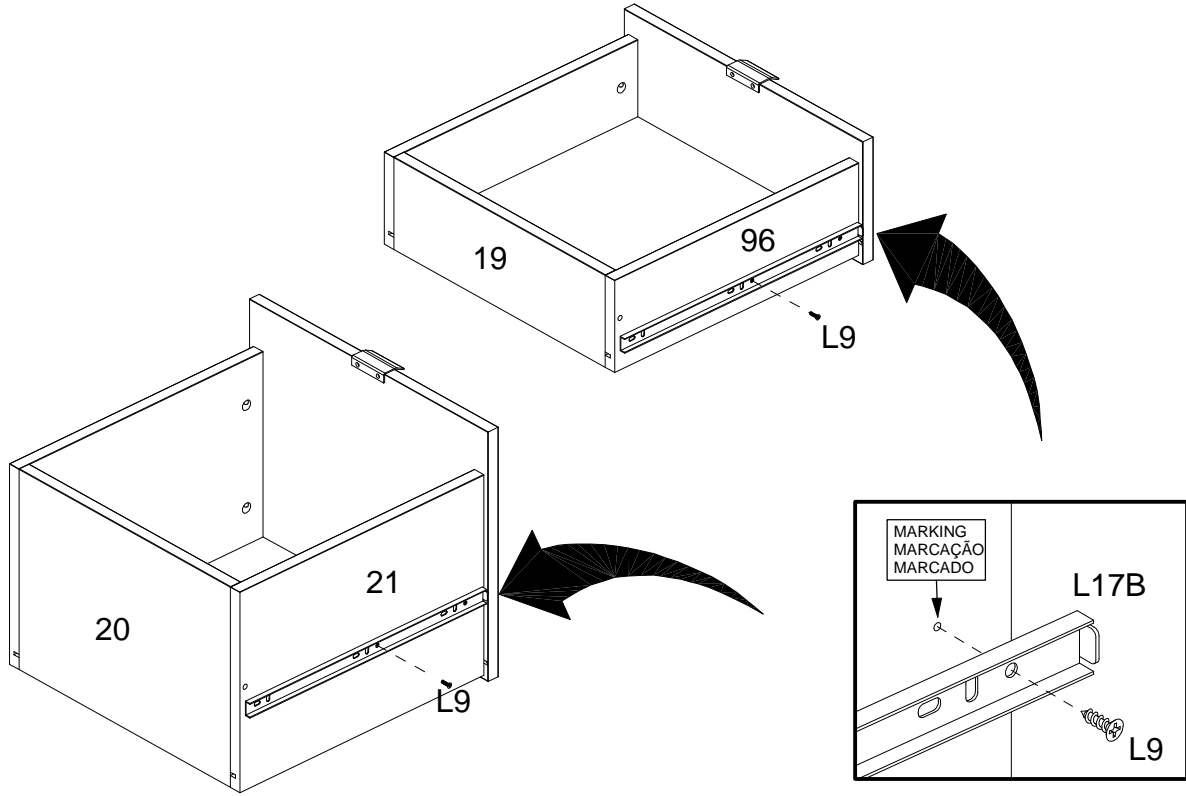

37

