

Rack com Painel DENVER

BC-1370

MANUAL DE MONTAGEM
INSTRUCCIONES DE ARMADO
ASSEMBLY INSTRUCTIONS

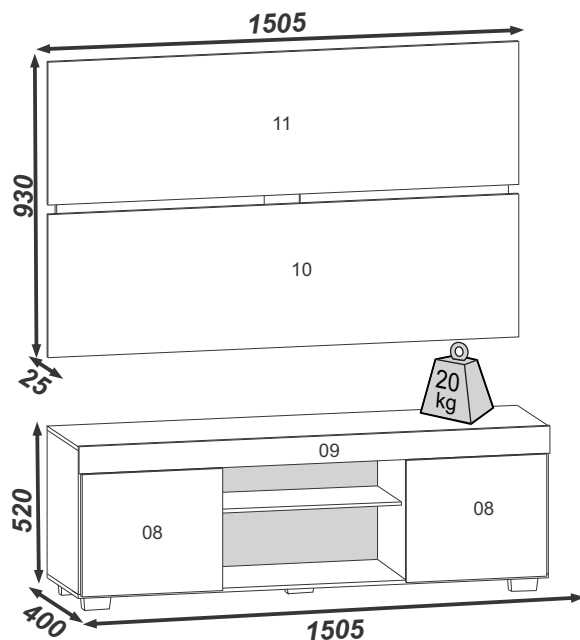

- Por**
- 01-Tampo Superior
 - 02-Tampo Inferior
 - 03-Lateral Esquerda
 - 04-Lateral Direita
 - 05-Divisoria Esquerda
 - 06-Divisoria Direita
 - 07-Prateleira
 - 08-Portas (2x)
 - 09-Frontal
 - 10-Painel Inferior
 - 11-Painel Superior
 - 12-Travessa Painel(2x)
 - 13-Travessa Parede Inferior (2x)
 - 14-Travessa Superior
 - 15-Costas Lateral (2x)
 - 16-Costa Furada
 - 17-Costa Central Inferior
 - 18-Travessa Superior Parede

- Lado**
- 01-Tapa Superior
 - 02-Tapa Inferior
 - 03-Lateral Izquierda
 - 04-Lateral Derecha
 - 05-Division Izquierda
 - 06-Division Derecha
 - 07-Estante
 - 08-Puertas (2x)
 - 09-Frontal
 - 10-Panel Inferior
 - 11-Panel Superior
 - 12-Travesaño Panel(2x)
 - 13-Travesaño Pared Inferior (2x)
 - 14-Travesaño Superior
 - 15-Dorso Lateral (2x)
 - 16-Dorso Furada
 - 17-Dorso Central Inferior
 - 18-Travesaño Superior Pared

- Lado**
- 01-Upper Top
 - 02-Lower Top
 - 03-Left Side
 - 04-Right Side
 - 05-Left Divider
 - 06-Right Divider
 - 07-Shelf
 - 08-Door(2x)
 - 09-Front
 - 10-Lower Panel
 - 11-Upper Panel
 - 12-Crossbar Panel(2x)
 - 13-Lower Crossbar Wall(2x)
 - 14-Upper Crossbar
 - 15-Side back Panel(2x)
 - 16-Back panel Bored
 - 17-Lower Center Back Panel
 - 18-Upper Crossbar Wall

DIMENSÕES PEÇAS PRONTAS
DIMENSIONES DE LAS PEZAS PRONTAS
DIMENSIONS READY MODE PARTS

- 01-1503 X 386 X 12
- 02-1503 X 386 X 12
- 03-451 X 385 X 12
- 04-451 X 385 X 12
- 05-451 X 385 X 12
- 06-451 X 385 X 12
- 07-607 X 299 X 12
- 08-383 X 449 X 15
- 09-1504 X 83 X 15
- 10-1503 X 449 X 15
- 11-1503 X 449 X 15
- 12-664 X 94 X 15
- 13-360 X 65 X 15
- 14-910 X 65 X 15
- 15-437 X 467 X 3
- 16-619 X 234 X 3
- 17-619 X 234 X 3
- 18-610 X 65 X 15

Ferragens/Herraje/Hardware:

330	A	Cavilhas 6 x 30 Clavija Wood Peg		20
0115	B	Parafuso minifix Tornillo Screw		08
0973	C	Tambor minifix 12 mm Minifix 12 mm Minifix 12 mm		08
3033	D	Cavilhas 6 x 25 Clavija Wood Peg		15
0477	E	Cola Pegamento Glue		01
0283	F	Parafuso 3,5 x 12 CC Tornillo Screw		22
0296	G	Taxa 10 x 10 Clavo 10 x 10 Nail 10 x 10		50
0293	H	Parafuso 3,5 x 14 CF Tornillo Screw		06
-----	I	Suporte Angular Preto Soporte Angular Negro Black Angular Bracket		06
0289	K	Parafuso 3,5 x 40 CC Tornillo Screw		10
0285	L	Parafuso 3,5 x 25 CF Tornillo Screw		20
0279	M	Fixador De Costa Fixador de Espalda Fix Back		11
1246	N	Parafuso 5 X 80 C Soberba Tornillo Screw		06
0512	O	Bucha plástica p/ concreto 8mm Buje plastica para hormigón 8mm Plastic bushing 8mm		06
-----	P	Tapa Furo Adesivo 18mm COR 1 Pegatina Para Agujeros 18mm COLOR 1 Slap hole adesivo 18mm color 1		10
298	S	Pino de Pé PRETO Passador de patas negro Black Foot Bolt		10
-----	T	Pé Quadrado Patás Cuadrada Square Foot		05
151	U	Dobradiça metal Bisagra Hinge		04

Instruções para a montagem do produto: Product assembly instructions: Instrucciones de montaje del Producto:

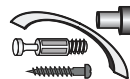

Separe as peças e acessórios de maneira organizada.

Separate the parts and accessories in an organized way.
Separe las piezas y accesorios de forma organizada



Forrar o chão com o papelão das embalagens.

Cover the floor with the cardboard from the pack.
Cubre el suelo con el cartón de los bultos.



É necessário duas pessoas para montar o produto.

It's necessary two people to assembly the product.
Se requiere dos personas para montar el producto.

Ferramentas necessárias(não fornecidas)

Herrajes necesarias (no incluye)
Necessary tools (not supplied)

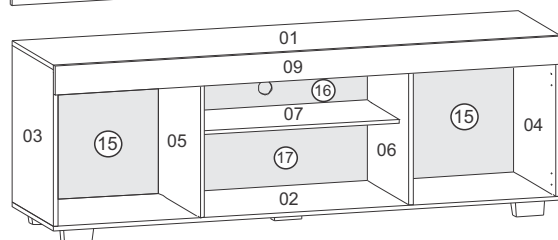
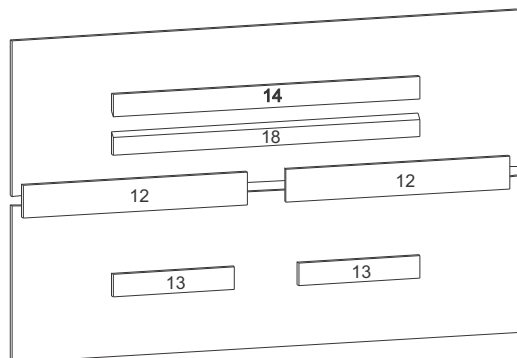
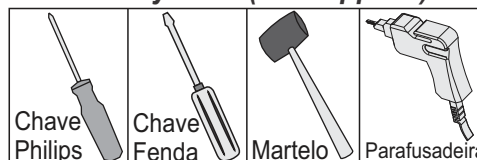

01° Passo
01° Paso
01° Step

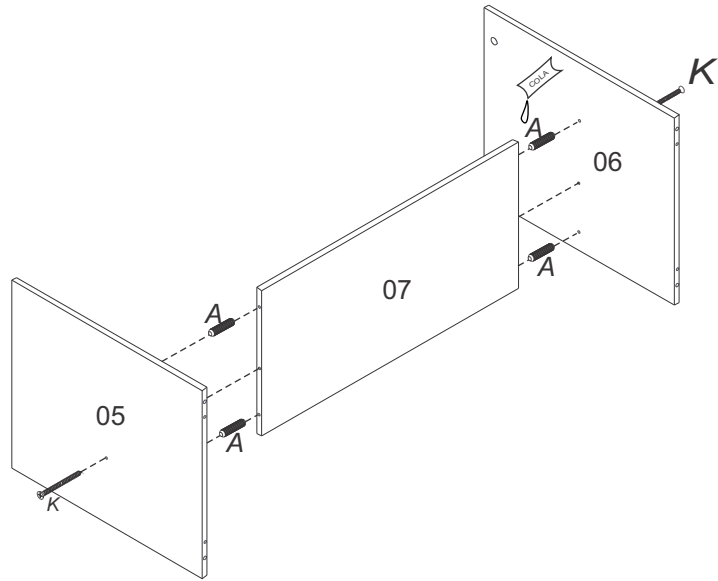

02° Passo
02° Paso
02° Step

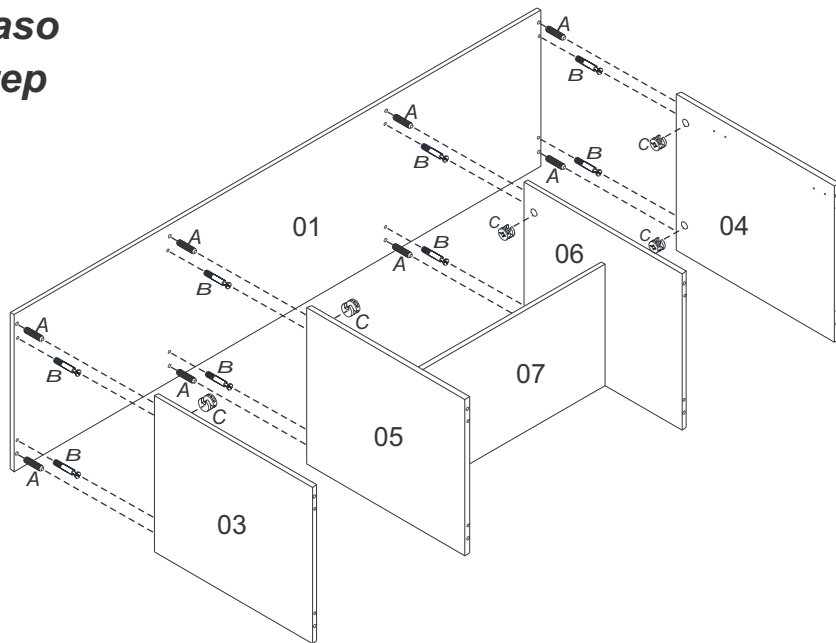

03° Passo
03° Paso
03° Step

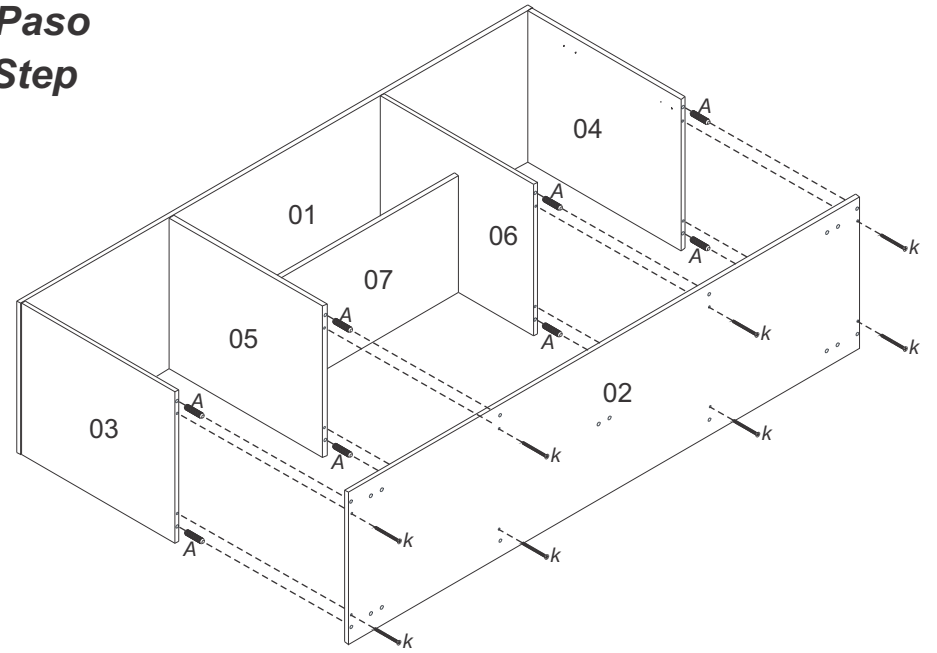

04° Passo
04° Paso
04° Step

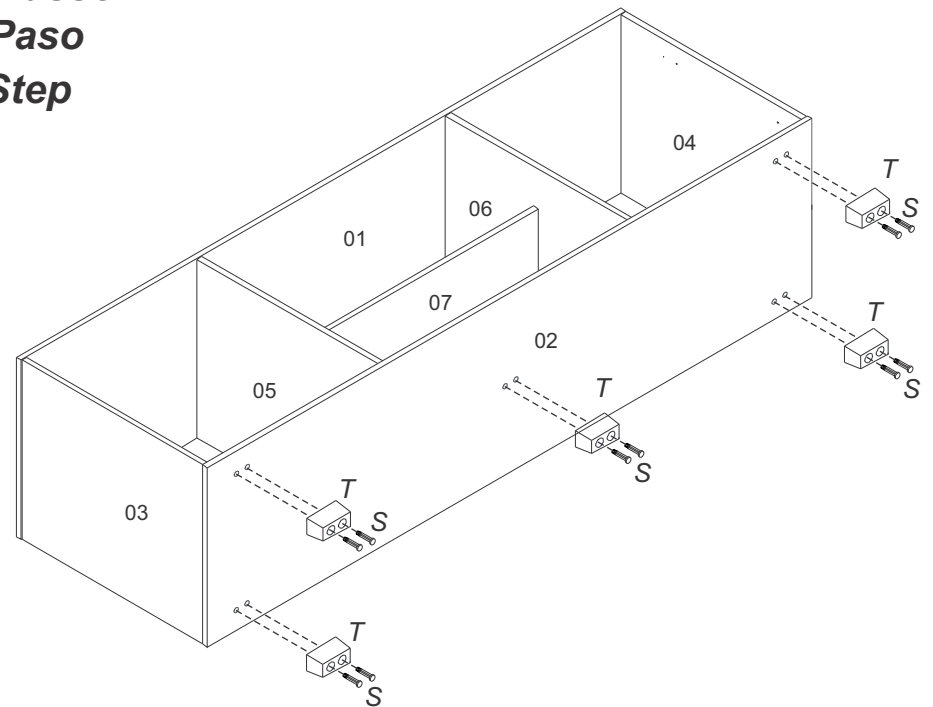

05° Passo

Seguir medidas para colocação do Suporte Angular.
Seguir medidas para poner el Soporte Angular.
Follow the measures to position the angular suport.

05° Paso

05° Step

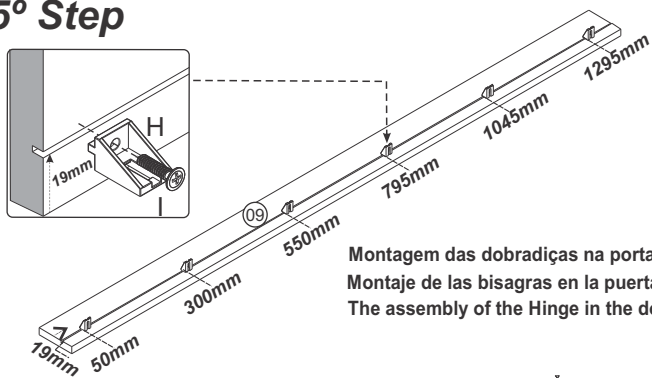

Usar parafuso 3,5x14CF (H)
Para fixar no Frontal (09)
Utilizar el tornillo 3,5x14CF (H)
Para fijar el los frontales (09)
Use screw 3,5x14CF (H)
To attach to the front (09)

Montagem das dobradiças na porta 08 colocando calço e dobradiça.
Montaje de las bisagras en la puerta 08 Poner la base y bisagra.
The assembly of the Hinge in the door 08 putting the base of Hinge and hinge.

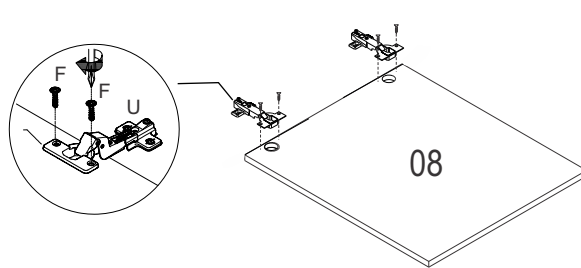

06° Passo

Nivelar o Frontal (09), e fixar nas peças (01) com Suporte Angular.
Nivelar el Frontal (09), y fijar las piezas (01) con Soporte Angular.
Level the fronts (09) and fixion the pieces (01) with angular suport.

06° Paso

06° Step

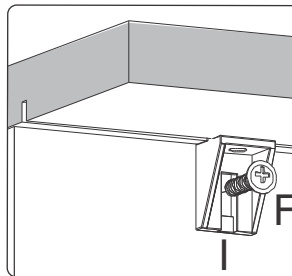
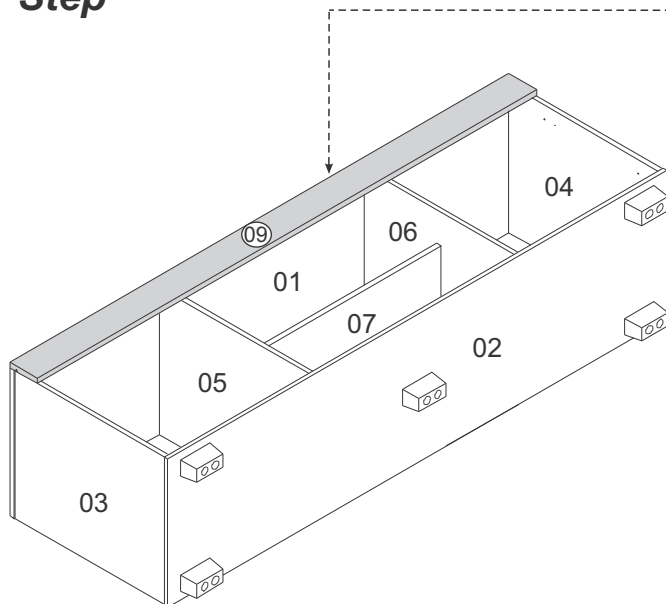

Usar parafuso 3,5x12cc (F)
Para fixar nas peças (01)
Utilizar el tornillo 3,5x12cc (F)
Para fijar en las piezas (01)
Use screw 3,5x12cc (F)
To attach the pieces (01)

07° Passo

07° Paso

07° Step

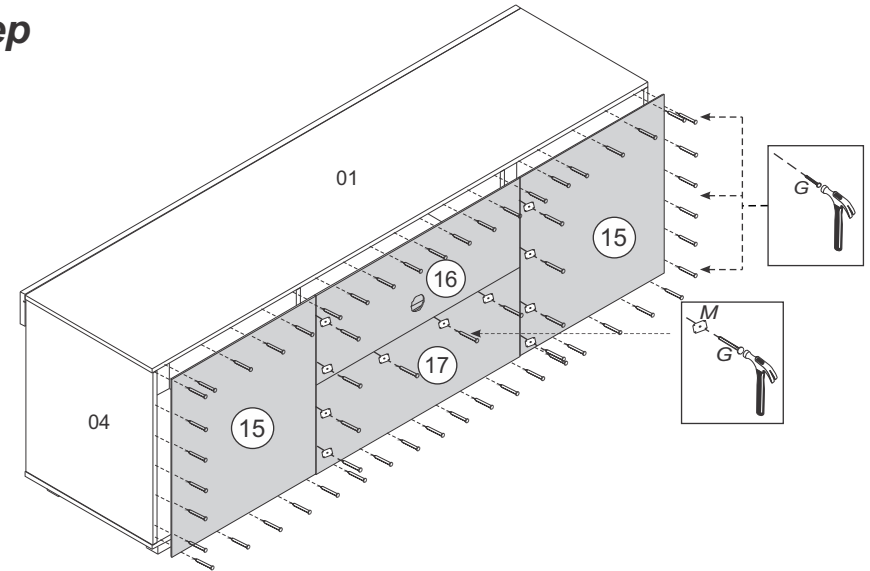

08° Passo

08° Paso

08° Step

EM TODAS AS PORTAS DA MESMA MANEIRA
EN TODAS LAS PUERTAS DE LA MISMA MANERA
ON ALL DOORS THE SAME WAY

REGULAGEM / REGLAJE / ADJUSTMENT

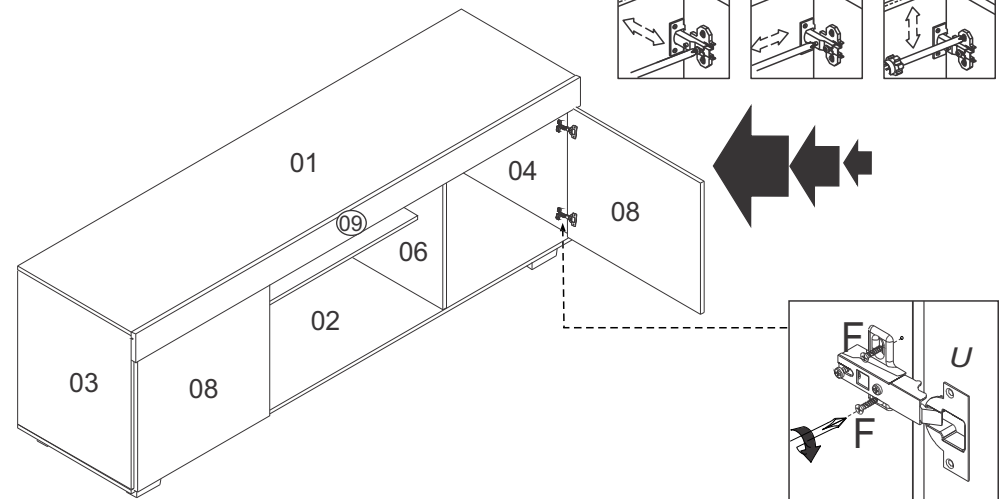
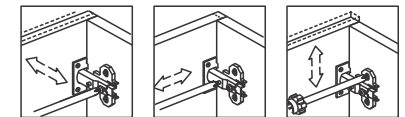

09º Passo

09º Paso

09º Step

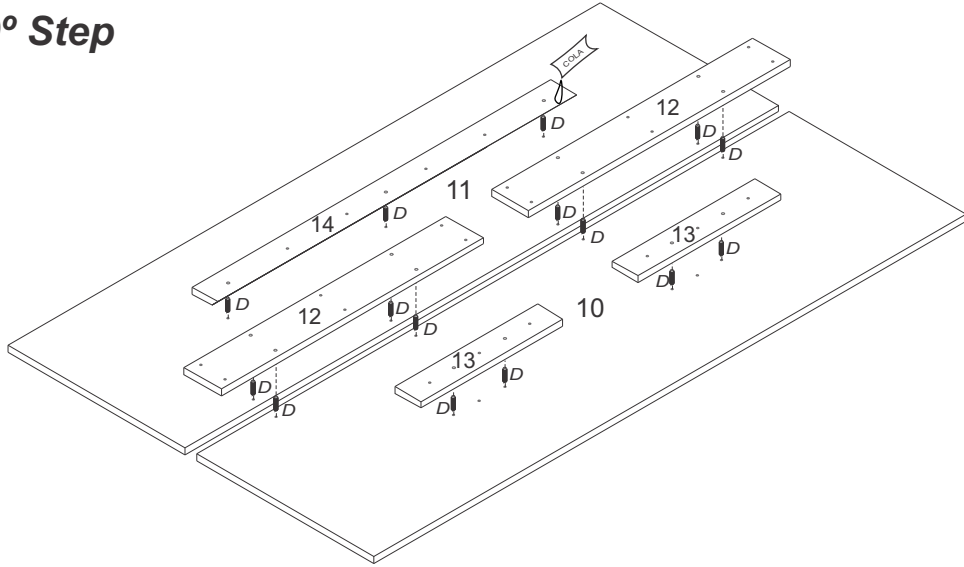

10º Passo

10º Paso

10º Step

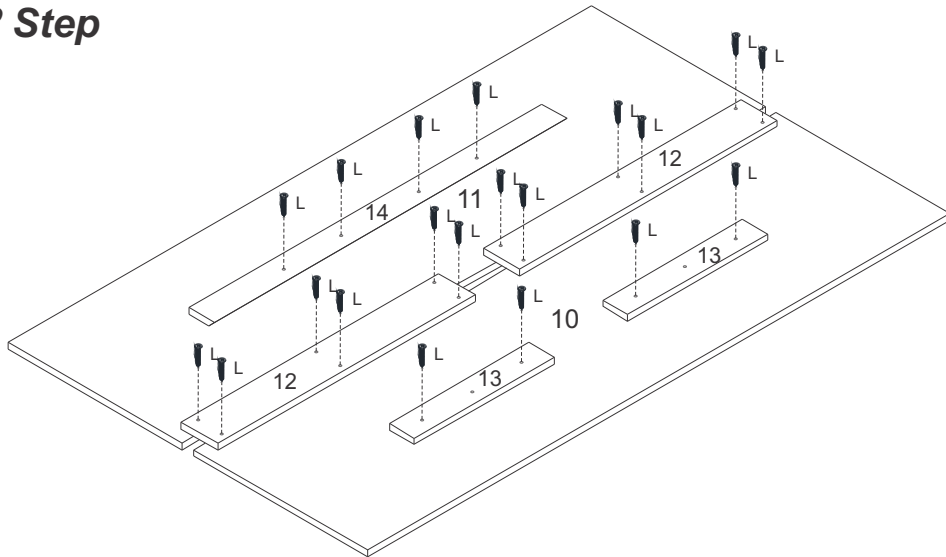

11º Passo

11º Paso

11º Step

Obs:

- * Com esta regulagem, o painel 11 permanece a uma distância de 1490 mm do piso.
- * Caso deseje uma altura diferenciada, deverá ajustar a travessa 18 de acordo com a medida desejada.
- * Con esta regulaje, el panel 11 permanece a una distancia de 1490 mm del piso
- * Caso quieras una altura diferenciada, debe ajustar la travesa 18 de acuerdo con la medida desejada.
- * With this adjust, the panel nº11 remain with a distance of 1490 mm from the floor
- * If you desire a different height, you should adjust the cross nº18 as you would like

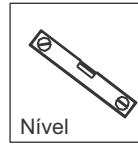

Dica:

Se possível utilize um nível para certificar que o painel ficará perfeitamente alinhado. **NÃO INCLUI NA FERRAGEM**

Si posible utilice un nivel para certificar que el panel se quedará perfectamente alineado. **NO INCLUI EN LA HERRAJE.**

If possible, use some level to certificate that the panel will be perfectly aligned. It isn't included

