



JCM
movelaria

Rack Cipó Cipó TV Unit Rack de TV Cipó



Indicamos que a montagem dos produtos seja realizada com parafusadeira eléctrica e por um montador profissional.

We recommend that the product assembly be performed with a cordless screwdriver and by a professional furniture assembler.
Se recomienda que el montaje de los productos sea realizado con un destornillador eléctrico y por un montador de muebles profesional.

AVISO: Não nos comprometemos pelo mal-uso, montagem e fixação do produto à parede. Portanto, não somos responsáveis por danos e quedas do produto, eletrônicos e pertences neles contidos. É importante o uso de brocas e ferramentas compatíveis na montagem.
ATTENTION: We are not responsible for misuse, assembly and wall fixation. Therefore, we are not responsible for damages and falls caused to the product, electronics and belongings therein. It is important to use suitable drills and tools for the assembly.
ATENCIÓN: No nos responsabilizamos del mal uso, montaje y fijación del producto a la pared. Por lo tanto, no somos responsables de daños y caídas del producto, electrónicos y objetos que contiene. Es importante el uso de taladros y herramientas compatibles con el montaje.

Dica: Para evitar possíveis avarias, use a embalagem do produto como apoio durante a montagem.







Tip: To avoid damages, use the product packaging as base during the assembly.

Pista: Para evitar daños, use el envase del producto como apoyo durante el montaje.

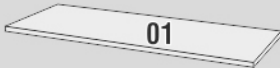
RELAÇÃO DE FERRAGENS | HARDWARE LIST | LISTADO DE HERRAJES

CAVILHA 6x30	(A)	6x30 DOWEL	(A)	CLAVIJA 6x30	(A)		08
PARAFUSO CHP CHA BC 3,5x35	(B)	3.5x35 SCREW	(B)	TORNILLO 3.5x35	(B)		06
PARAFUSO ESTR CHA PHI ZP 5x40	(C)	5x40 SCREW	(C)	TORNILLO 5x40	(C)		08
PARAFUSO MINIFIX	(D)	MINIFIX SCREW	(D)	PERNO MINIFIX	(D)		04
PÉ	(E)	FOOT	(E)	PATA	(E)		06
PREGO 8x8 C/C	(F)	8x8 NAIL	(F)	CLAVO 8x8	(F)		24
TAMBOR MINIFIX 12x10mm	(G)	12x10mm MINIFIX NUT	(G)	TUERCA MINIFIX 12x10mm	(G)		04

RELAÇÃO DE PEÇAS | PARTS LIST | LISTADO DE PARTES

	Base Base Base	1Pc
	Lateral Esquerda Left Panel Lateral Izquierdo	1Pc
	Lateral Direita Right Panel Lateral Derecho	1Pc
	Prateleira Shelf Estante	2Pc
	Tampo Superior Upper Cover Tapa Superior	1Pc
	Costas Inferior Lower Back Trasera Inferior	1Pc
	Costas Superior Upper Back Trasera Superior	1Pc

PASSO 01 COMECE A MONTAGEM PELAS PEÇAS 02 E 03, ENCAIXE E PARAFUSE AS PEÇAS 05 NAS PEÇAS 02 E 03 COM PARAFUSO 5x40(C) E CAVILHA(A).
 STEP 01 START ASSEMBLING FROM PARTS 02 AND 03, ATTACH AND SCREW PART 05 INTO PART 02 AND 03 WITH 5x40 SCREW(C) AND DOWEL(A).
 PASO 01 EMPIECE EL MONTAJE POR LAS PARTES 02 Y 03, ENCAJE Y ATORNILLE LA PARTE 05 A LAS PARTES 02 Y 03 CON TORNILLO 5x40(C) Y CLAVIJA(A).

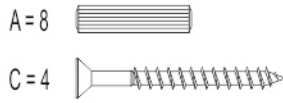
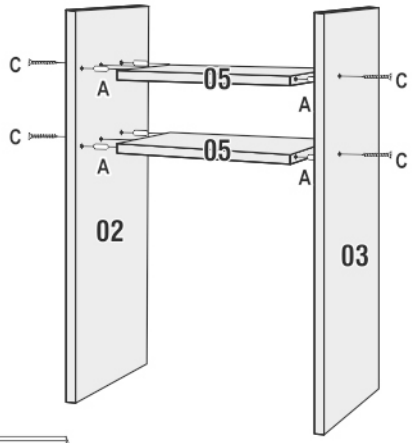

PASSO 02 ENCAIXE E APERTE A PEÇA 06 JUNTO AS PEÇAS 02 E 03 COM MINIFIX(D+G).
 STEP 02 ATTACH AND TIGHTEN PART 6 INTO PARTS 02 AND 03 WITH MINIFIX(D+G).
 PASO 02 ENCAJE Y APRIETE LA PARTE 06 EN LAS PARTES 02 Y 03 CON MINIFIX(D+G).

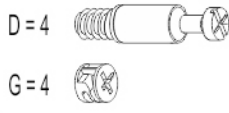
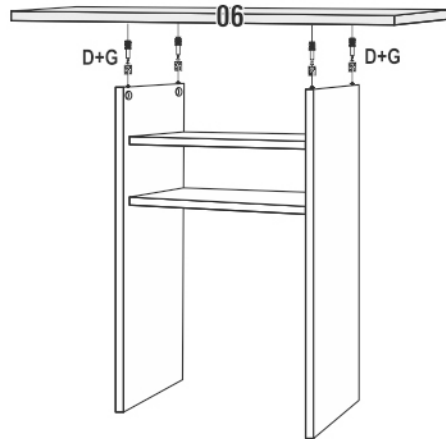

PASSO 03 PARAFUSE OS PÉS(E+B) NA PEÇA 01 E PARAFUSE A PEÇA 01 NAS PEÇAS 02 E 03 COM PARAFUSO 5x40(C).
 STEP 03 SCREW THE FEET(E+B) INTO PART 01 AND SCREW PART 01 INTO PARTS 02 AND 03 WITH 5x40 SCREW(C).
 PASO 03 ATORNILLE LAS PATAS(E+B) A LA PARTE 01 Y ATORNILLE LA PARTE 01 A LAS PARTES 02 Y 03 CON TORNILLO 5x40(C).

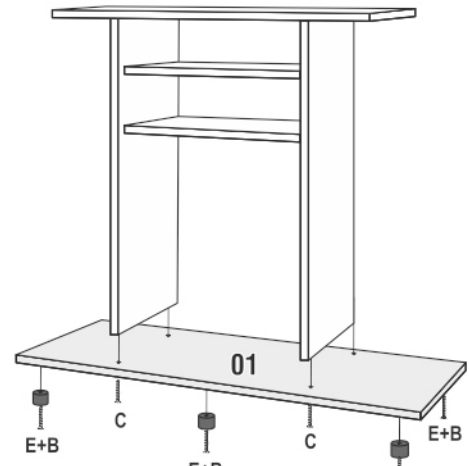

PASSO 04 LEVANTE O MÓVEL E PREGUE AS COSTAS 07 E 08 COM PREGO 8x8(F).
 STEP 04 LIFT THE PIECE AND NAIL THE BACK 07 AND 08 WITH 8x8 NAIL(F).
 PASO 04 ERGA EL MUEBLE Y CLAVE LA TRASERA 07 E 08 CON CLAVO 8x8(F).

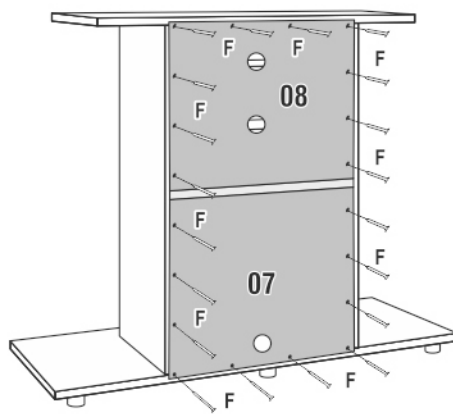

PASSO 05 PRODUTO MONTADO.
 STEP 05 PRODUCT ASSEMBLED.
 PASO 05 PRODUCTO MONTADO.

