



**MANUAL DE MONTAGEM
ASSEMBLY INSTRUCTIONS
INSTRUCCIONES DE MONTAJE**

COD BR: BHO 25 | BHO 54 | BM 225 | BS 48 | BSE 01| BWO 18

Sumário Summary Resumen

Introdução Introduction Introducción	3
Antes de começar Before starting Antes de comenzar	4
Evite acidentes Avoid accidents Evitar accidentes	4
Dimensões e ferramentas Dimensions and tools Dimensiones y herramientas	5
Identificação das peças Identifying parts Identificación de las piezas	6
Acessórios incluídos na caixa Hardware included in box Accesorios incluidos en la caja	7
Montagem do móvel Furniture assembly Montaje del mueble	8

Introdução Introduction Introducción

Leia atentamente este manual e siga os passos indicados para que o produto não perca a garantia e também para uma perfeita montagem.

Read this manual and follow the steps in order to keep the guarantee and also for the perfect fit.

Lea este manual y siga los pasos para que el producto no pierda la garantía y también para el ajuste perfecto.

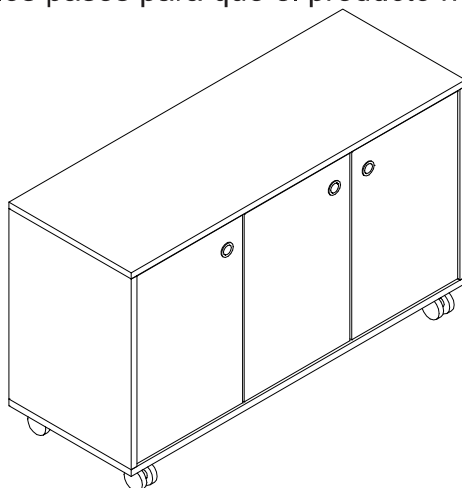

Antes de começar Before starting Antes de comenzar

Antes de começar a montagem prepare o ambiente, deixando-o completamente limpo e com bom espaço para iniciar o trabalho.

Prepare the room before starting the assembly, leaving it completely clean and the area in good condition to start the work.

Antes de comenzar el montaje prepare el ambiente, dejándolo completamente limpio y con espacio para empezar el trabajo.

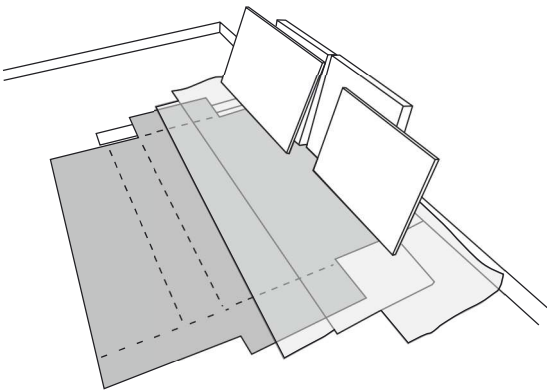

Utilize o papelão da própria embalagem para separar e apoiar as peças retiradas das caixas.

Use the cardboard of the packaging to separate and support the parts removed from the boxes.

Utilice el cartón del embalaje para separar y apoyar las piezas.

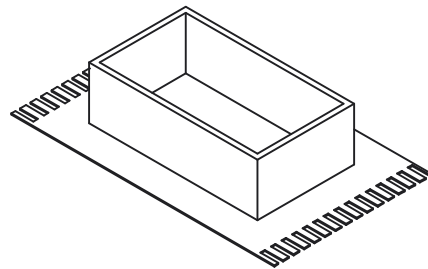

Forre a área de montagem com um cobertor ou tapete. Assim, você evita avarias nas peças durante o processo de montagem.

Cover the assembly area with a blanket or carpet to avoid damaging the parts during the assembly process.

Cubrir la zona de ensamble con una manta o alfombra. De este modo, se evitan daños en las piezas durante el proceso de montaje.



Evite acidentes Avoid accidents Prevenir accidentes

Solicitamos observar atentamente as orientações de montagem como: fixação do produto na parede, colocação de cola em locais específicos necessários, o peso suportado pelo produto, etc...

You are requested to carefully observe the assembly instructions regarding: fixing of products to the wall, adding glue where indicated, product weight limit, etc.

Pedimos que lea atentamente las instrucciones, principalmente las informaciones de fijación del producto en la pared, colocación de pegamento en local específico y necesario, el peso soportado por el producto etc...

Não escale ou se apoie no móvel.

Do not climb or lean on the furniture.

No se suba ni se apoye en el mueble.

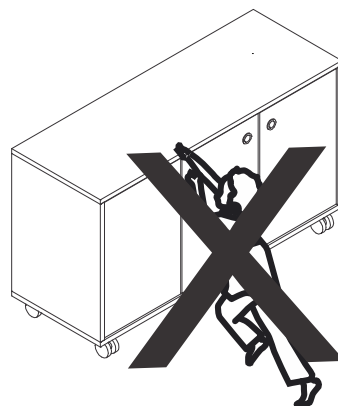

Dimensões e ferramentas
Dimensions and tools
Dimensiones y herramientas

Dimensões:

L: 900 A: 535 P: 330 mm

Dimensions:

W: 35.43 H: 21.06 D: 12.99 inches

Dimensiones:

L: 900 A: 535 P: 330 mm

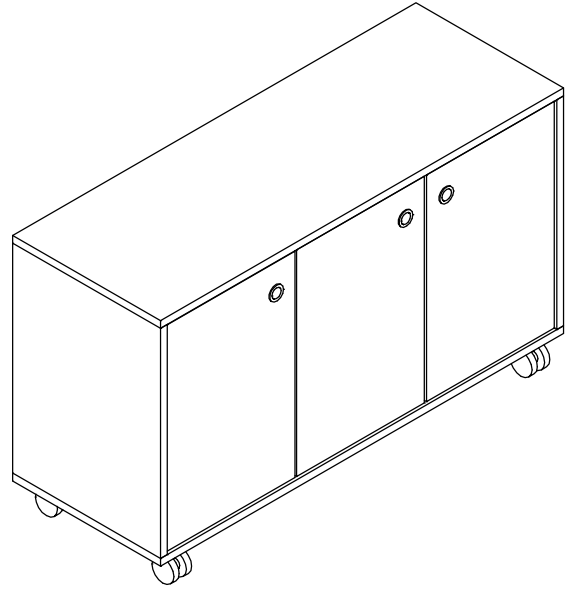

Limpeza
Cleaning
Limpieza

Pano levemente umedecido com água, seguido de pano seco, não utilizar produtos químicos ou abrasivos.
You can clean the product with slightly dampened cloth followed by a dry cloth. Do not use chemicals or abrasives.
Solamente utilizar un paño húmedo y después un paño seco, no utilice productos químicos o abrasivos.

Todas as peças do móvel foram marcadas com um número. Antes de começar a montagem, identifique as peças numeradas em relação às instruções de montagem. Uma vez concluída a montagem, os números podem ser facilmente removidos com um pano ligeiramente embebido em álcool. Use álcool apenas para remover números das peças.

All the furniture parts have been marked with a number. Before you start assembling, please identify the numbered parts in relation to the assembly instructions. Once assembly is completed, the numbers can be easily removed with a cloth slightly dampened in alcohol. Use alcohol only to remove part numbers.

Todos las piezas del mueble fueron marcadas con un número. Antes de empezar el montaje, identifique las piezas numeradas en relación con las instrucciones de montaje. Una vez que se completa el armado, los números se pueden quitar fácilmente con un paño ligeramente empapado en alcohol. Use alcohol solo para eliminar los números de las piezas.

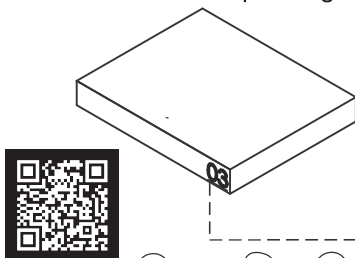

UTILIZE ALCOOL APENAS PARA REMOVER O NUMERO DAS PEÇAS
USE ALCOHOL ONLY TO REMOVE PART NUMBERS
UTILICE ALCOHOL SOLAMENTE PARA ELIMINAR EL NUMERO DE LAS PIEZAS

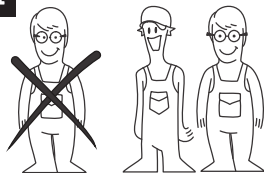

Para facilitar a montagem, utilize uma parafusadeira elétrica.
To speed assembly, use an electronic screwdriver.
Para facilitar el armado, utilice un destornillador eléctrico.

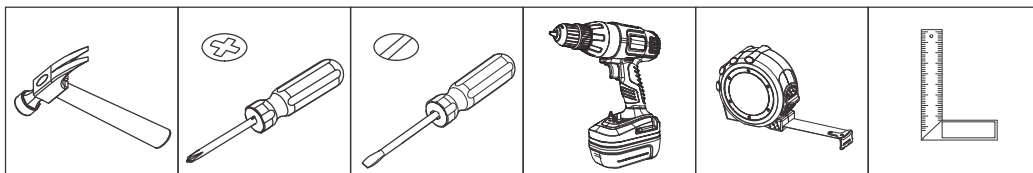

COD BR: BHO 25 | BHO 54 | BM 225 | BS 48 | BSE 01| BWO 18

PEÇA	DESCRIÇÃO	QUANT.	PART	DESCRIPTION	QTY	PIEZA	DESCRIPCIÓN	CANTIDAD
001	BASE	1	001	BASE	1	001	BASE	1
002	TAMPO	1	002	TOP	1	002	TAPA	1
003	LATERAL DIREITA	1	003	RIGHT SIDE	1	003	LATERAL DERECHA	1
004	LATERAL ESQUERDA	1	004	LEFT SIDE	1	004	LATERAL IZQUIERDA	1
005	DIVISÓRIA	1	005	PARTITION	1	005	DIVISÓRIO	1
006	PRATELEIRA	1	006	SHELF	1	006	ESTANTE	1
007	PORTA ESQUERDA	2	007	LEFT DOOR	2	007	PUERTA IZQUIERDA	2
008	PORTA DIREITA	1	008	RIGHT DOOR	1	008	PUERTA DERECHA	1
009	COSTAS	3	009	BACK	3	009	REVÉS	3

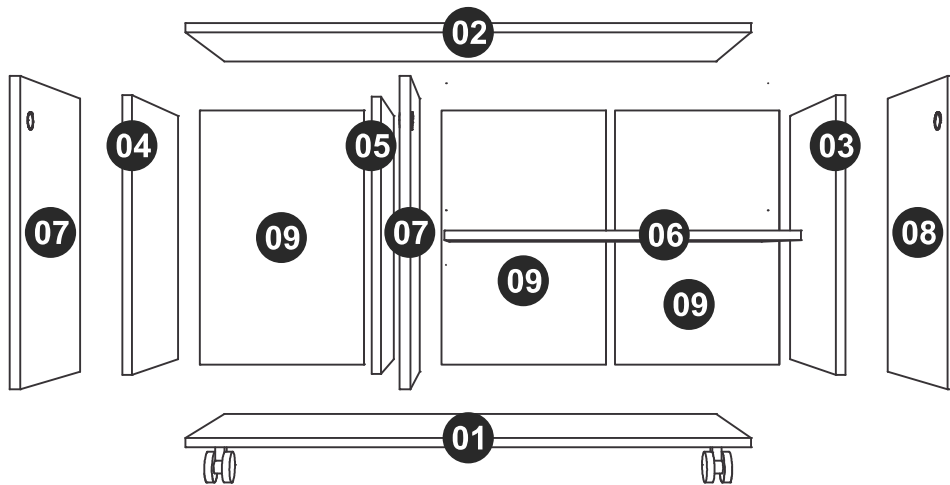



A- 
EF 000032 x 12
6x30

B- 
EF 000892 x 3

D- 
EF 000101 X 46
3,5X12CC

E- 
EF 000830 x 6
3x40 CC

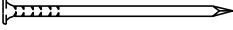
F- 
EF 000168 X 40
10x10 C/C

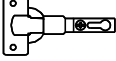
G- 
EF 000043 X 6

H- 
EF 000025 X 6

J- 
PUXADOR x 3
HANDLE x 3
MANIJA x 3

M- 
SUPORTE PLÁSTICO x 4
PLASTIC SUPPORT x 4
SOPORTE PLASTICO x 4

P- 
RODÍZIOS x 4
CASTERS x 4
RUEDAS x 4

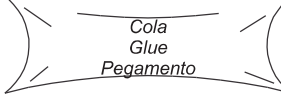
Q- 
EF 000008 x 1
*Cola
Glue
Pegamento*

Y- 
GIZ x 01
CHALK x 01
TIZA x 01

Z- 
TAPA FUROS x 06
STICKER x 06
TAPA HUECOS x 06

Utilize para medir as ferragens.

Utilice para medir el herraje.

Use for measuring the hardware.

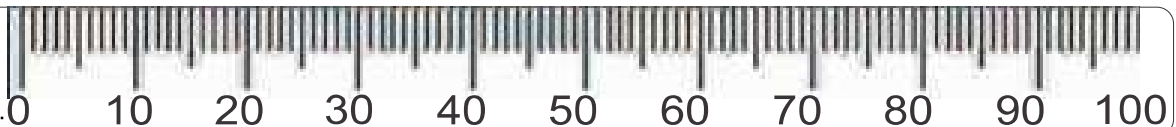

Garantia (exclusivo para o Brasil/exclusivo de Brasil/exclusive to Brazil):

A garantia dos produtos fabricados pela BRV Móveis, abrange eventuais defeitos-vícios de fabricação, no prazo estabelecido pelo código de Defesa do Consumidor, em seu artigo 26.II. o qual prevê a garantia de 90 (noventa) dias.

A = 4 KG - 8.81 LB

B = 6 KG - 13.22 LB

C = 10 KG - 22.04 LB

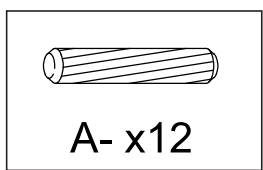
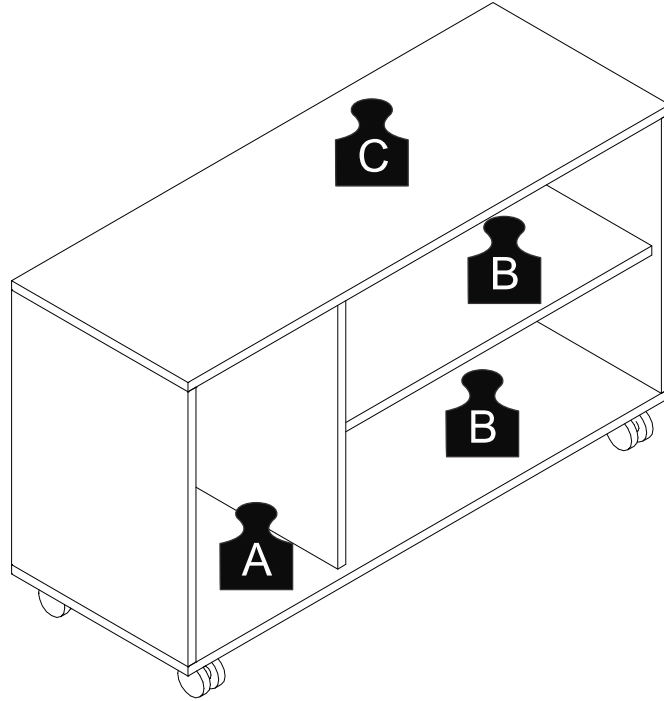

1

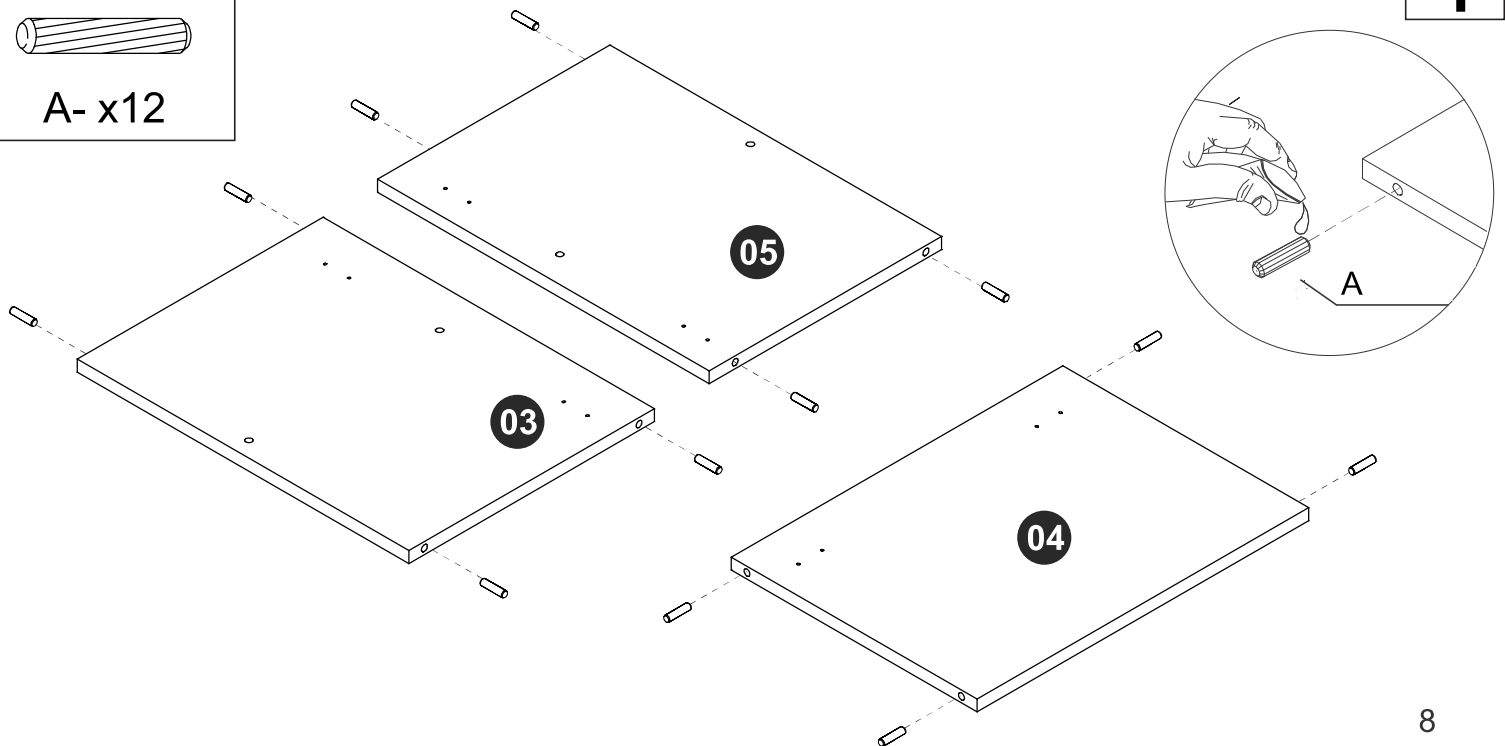

2



M- x4

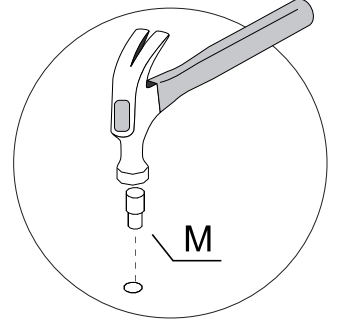
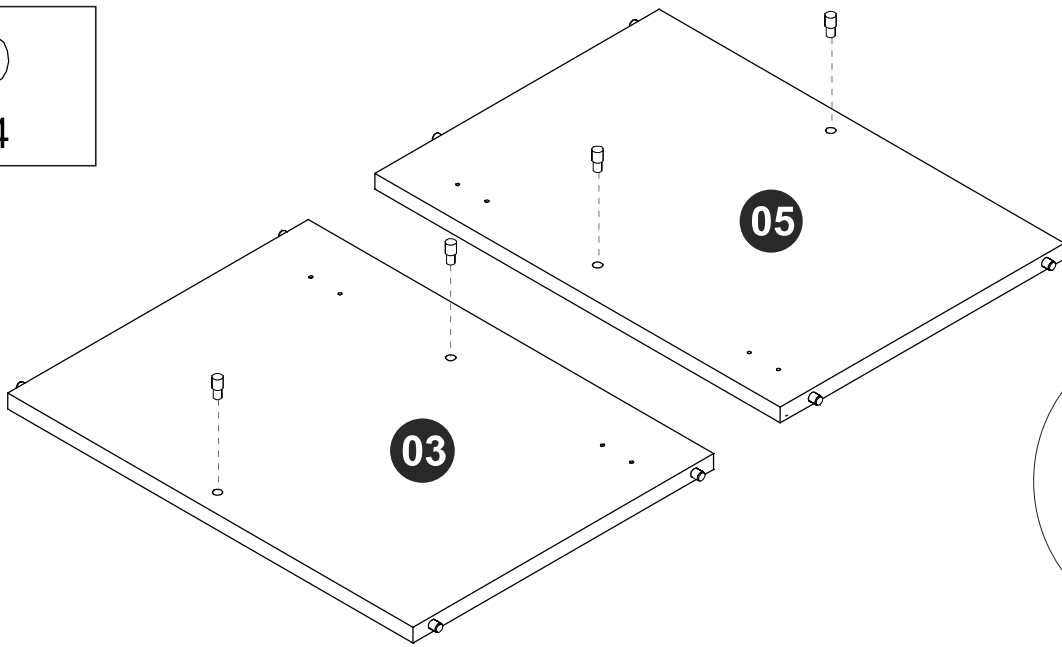

3



D- x12



H- x6

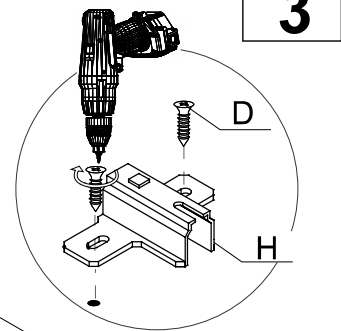
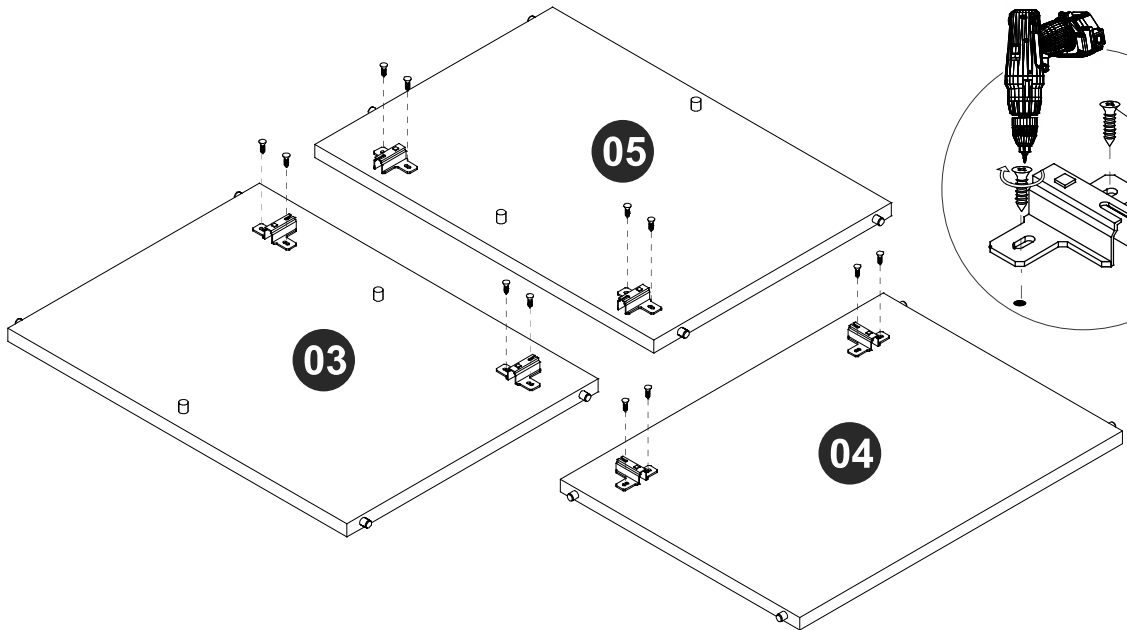

4



D- x12

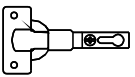

G- x6



J- x3

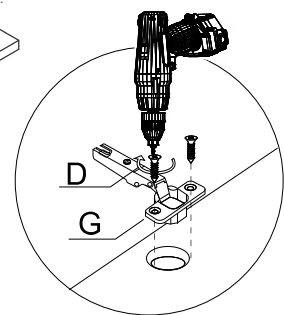
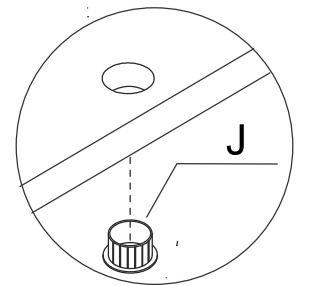
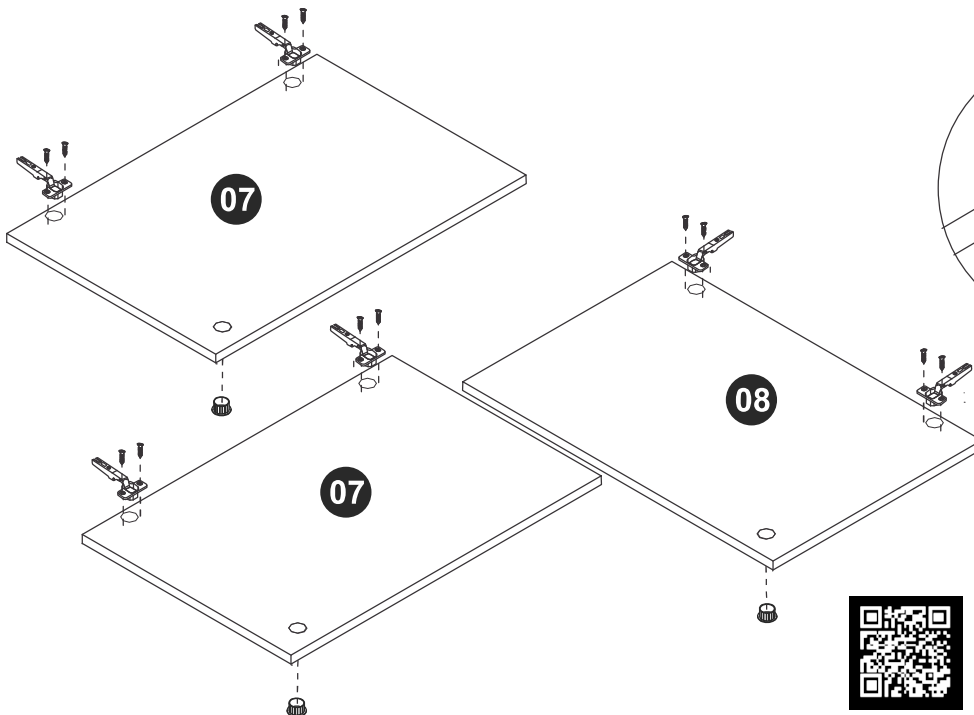

5

B- x3

D- x6

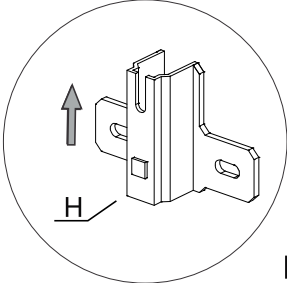
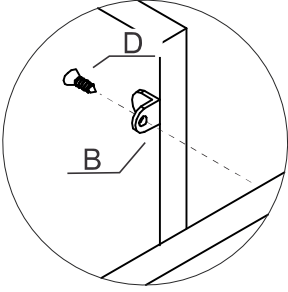
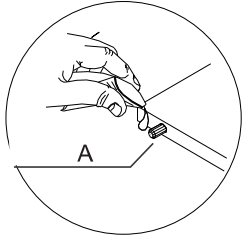
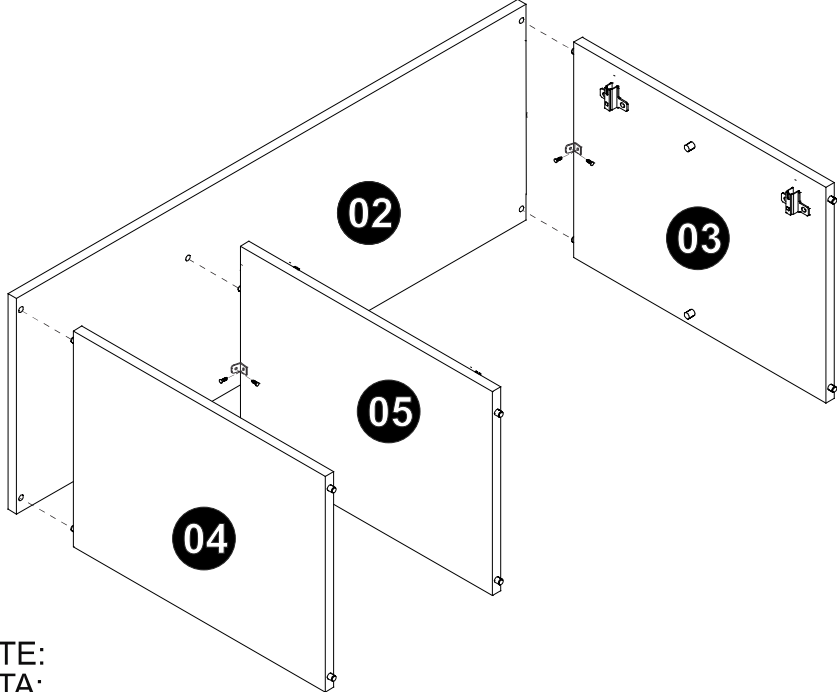

NOTE:
NOTA:

6

E- x6

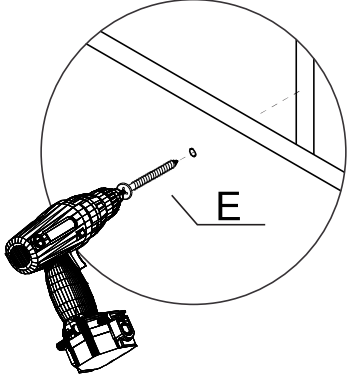
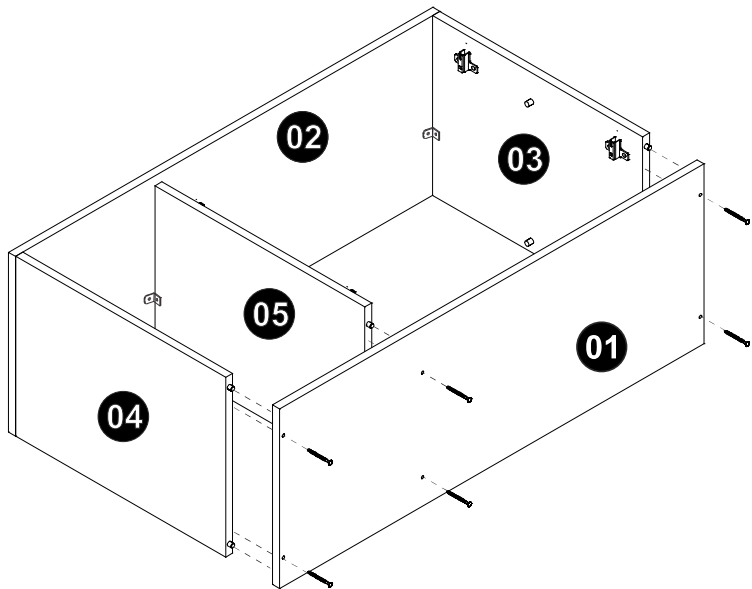

NOTE:
NOTA:

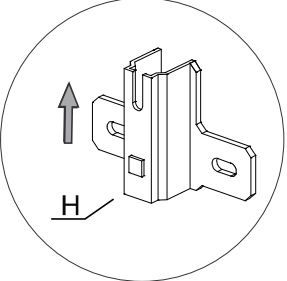

7

D- x16

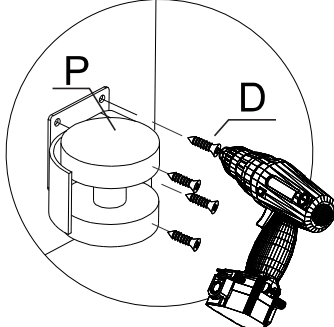
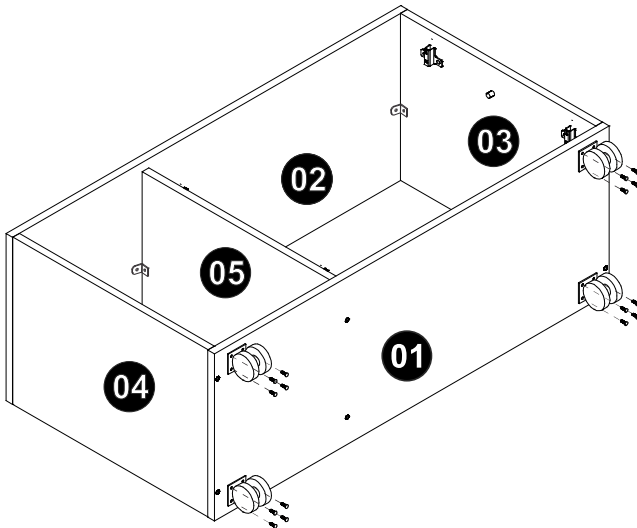

P- x4

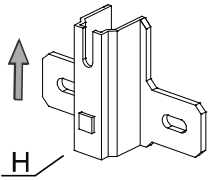

NOTE:
NOTA:

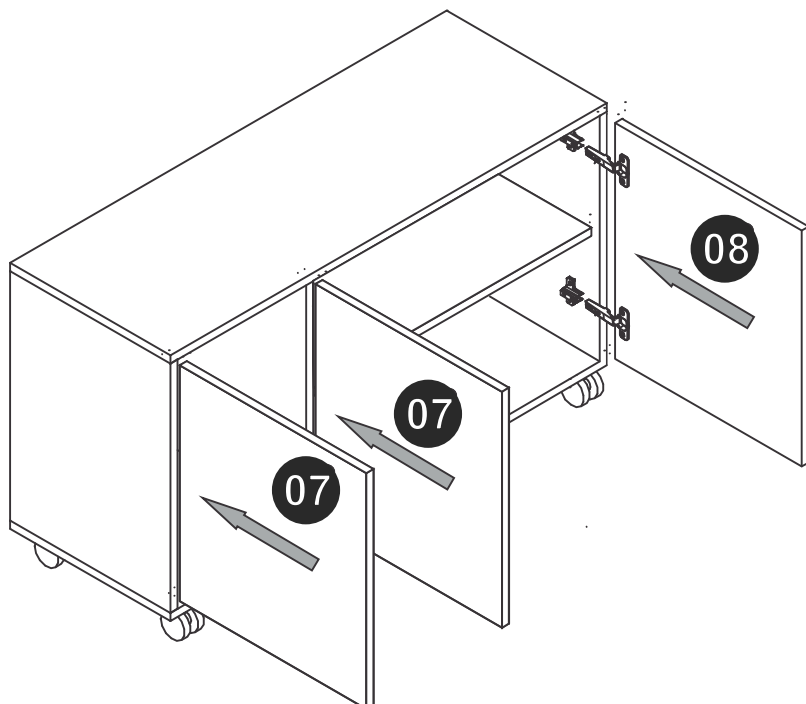
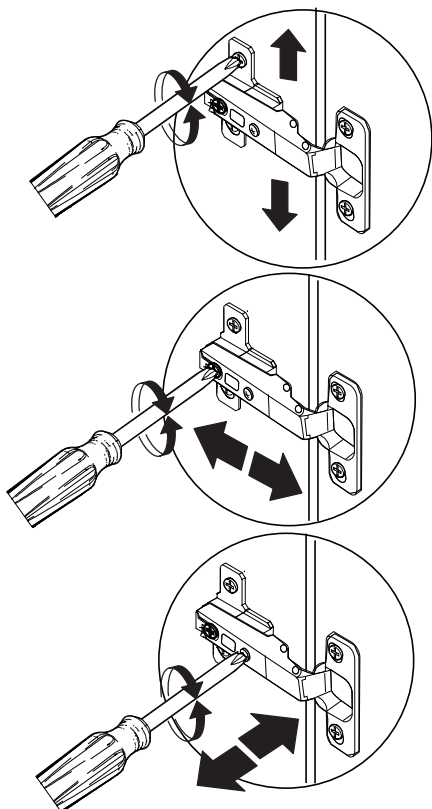
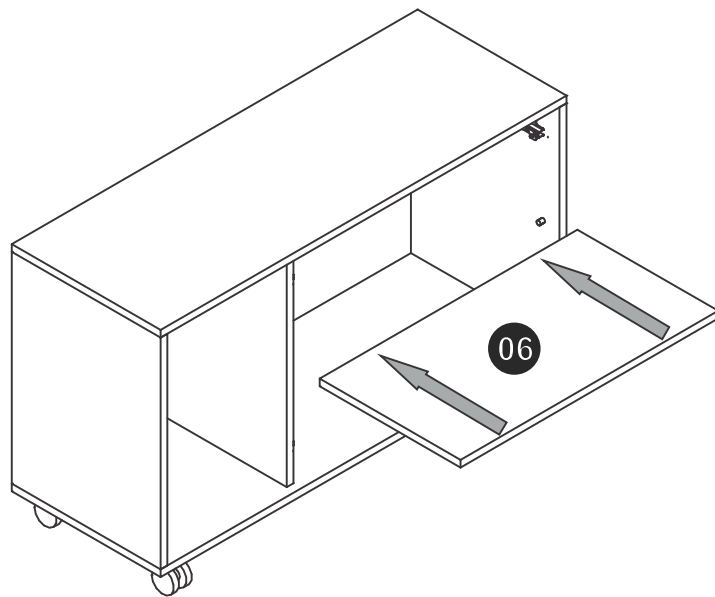
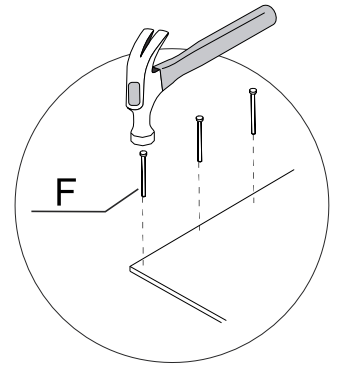
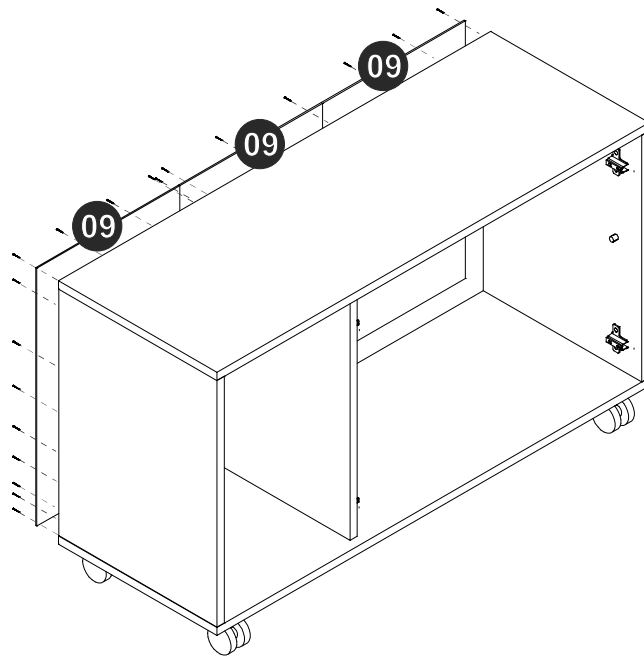
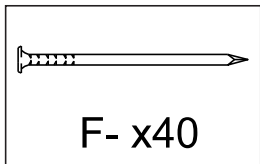

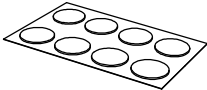

Z- x06

Y- x1

