

PEÇAS NUMERADAS/ NUMBERED PARTS/
PIEZAS NUMERADAS
EX: 1915X-X 05 (peça/ piece/ pieza number)

DIMENSÕES DO PRODUTO / PRODUKT DIMENSIONS / DIMENSIONS PRODUCT - WxDxH / LxDxA - 1350 X 353 X 594 MM

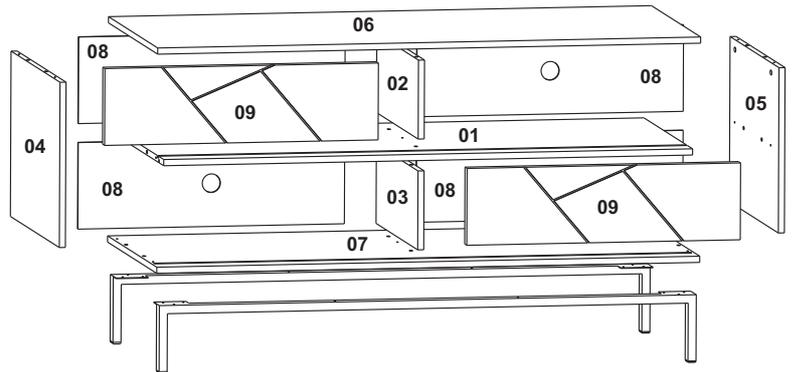
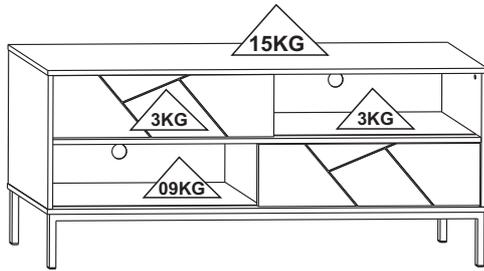

ATENÇÃO / ATTENTION / ATENCION
Nunca utilizar óleos, lustra móveis, produtos abrasivos, saponáceos, esponja de aço e outros.
Never use oils, furniture polish, abrasive products, soaps, steel sponge and others.
Nunca use aceites, pulimentos, abrasivos, jabones, esponja de acero y otros.

CUIDADOS ESPECIAIS/ SPECIAL CARE/ CUIDADOS ESPECIALES
- Evitar expor o móvel ao sol, e em lugares úmidos.
- Limpar com flanela seca ou com pano levemente umedecido em água.
- Avoid exposing the furniture to the sun, and in damp places.
- Clean with dry flannel or lightly cloth moistened with water.
- Evite exponer los muebles al sol y en lugares húmedos.
- Limpiar con flanela seca o un paño ligero, humedecido con agua.

Ferramentas necessárias / Necessary tools / Herramientas Necesarias (não fornecidas) (not provided) (No proporcionadas)

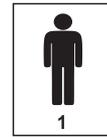

MONTAR O PRODUTO SOBRE A EMBALAGEM, EVITANDO DANOS NA PINTURA. ACONSELHAMOS QUE A MONTAGEM DO PRODUTO SEJA POR UM PROFISSIONAL.

SETUP THE PRODUCT ON TOP OF THE PACKAGING, AVOIDING DAMAGE TO THE PAINT. WE RECOMMEND THAT THE INSTALLATION IS DONE BY A PROFESSIONAL.

MONTAR EL PRODUCTO EN EL PAQUETE, EVITAR LESIONES EN PINTURA. AVISAMOS QUE EL MONTAJE DEL PRODUCTO SEA UN PROFESIONAL.

ITEM		DESCRIÇÃO DA PEÇAS / DESCRIPTION OF PARTS / UNIT MEASURE USED IS MILLIMETERS (MM)	CORES/ COLORS/ COLORES					
COD. CODE	Nº	NOME/NAME/NOMBRE	MEDIDAS / MEASURES (MM)	QUANT AMOUNT CANTIDAD	TIPO TYPE	OFF WHITE	PRETO NEGRO BLACK	AZUL NAVY
16815	1	PRATELEIRA / SHELF / ESTANTE	1315X346X15	1	MDP	01/06	01/07	01/15
16816	2	DIVISOR SUPERIOR / HIGHER DIVIDER	296X192X15	1	MDP	02/06	02/07	02/15
16817	3	DIVISOR INFERIOR / BOTTOM DIVIDER /	296X192X15	1	MDP	03/06	03/07	03/15
16818	4	LATERAL ESQUERDA / LEFT SIDE / LADO IZQUIERDO	400X348X15	1	MDP	04/06	04/07	04/15
16819	5	LATERAL DIREITA / RIGHT SIDE / LADO DERECHO	400X348X15	1	MDP	05/06	05/07	05/15
16820	6	TAMPO / TOP	1350X350X15	1	MDP	06/06	06/07	06/15
16821	7	BASE	1350X350X15	1	MDP	07/06	07/07	07/15
16822	8	FUNDO TRÁS / BACK / TRASEIRO	662X209X3	4	MDF	08/06	08/07	08/15
16823	9	PORTA / DOOR / PUERTA	680X186X15	2	MDF	09/06	09/07	09/15
438	A	PF. / Screw / Tornillo 4,0x40(MM) CH		6				
436	B	PF. / Screw / Tornillo 4,0x30(MM)		8				
986	C	PF. / Screw / Tornillo 3,5x14(MM) CRR		8				
137	D	Cavilha / Wooden Dowel / Tarugo 8x30(MM)		20				
532	E	Pino Minifix / Minifix Screw 32(MM)		10				
508	F	Tambor Minifix / Minifix Round Nut 15(MM)		10				
13877	G	Tapa Furo Adesivo / Holler Stiker / Pegatina de Agugero 18 (MM)		06		GELO		
13363							PRETO	
13878								AZUL.N
911	H	Garra / Jont Metal Plate / Embragues		11				
248	I	Prego / Nail / Clavo 8x8(MM)		50				
16943	J	Trilho PL / Rail 1314 (MM)		01		OFF W.		
16942							PRETO	PRETO
16947							OURO	OURO
16946	J	Estrutura de Metal / Metal Structure / Estructura Metalica 1335X40X169 (MM)		02		PRETO		
3441	K	Amortecedor / Pu Bumper / Parachoques Poliuretanos		04				
9002	L	Kit Porta de correr / Sliding Door Kit / Kit Puerta Corrediza		01				
		Certif. de Garant. / Warranty Certif.		01				

MEDIDA UTILIZADA EM MM / UNIT MEASURE USED IS MILLIMETERS (MM)

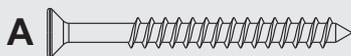

PF / SCREW / TORNILLO 4.0X40(MM) CH (06)



PF / SCREW / TORNILLO 4,0x30 (MM) CH (08)

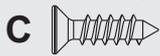

PF / SCREW / TORNILLO 3.5x14CRR (66)



CAVILHA / WOODEN DOWEL TARUGO 8X30 (MM) (20)

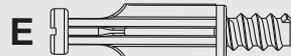

PINO MINIFIX / MINI FIX SCREW 32 (MM) (10)



TAMBOR MINIFIX / MINI FIX ROUND NUT 15 (MM) (10)



TAPA F. ADES. / HOLLER STIKER / PEGATINA DE AGUGERO 18 MM(06)



GARRA / JONT METAL PLATE EMBRAGUES (11)



PREGO / NAIL / CLAVO 8X8 (MM) (50)



TRILHO / RAIL 1314 (MM) (02)

K AMORTECEDOR / PU BUMPER / PARACHOQUES POLIURETANO (08)

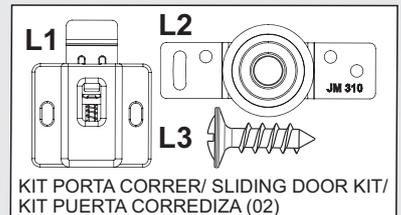

KIT PORTA CORRER / SLIDING DOOR KIT / KIT PUERTA CORREDIZA (02)



ESTRUTURA DE METAL / METAL STRUCTURE / ESTRUCTURA METALICA 1335x40x164 MM(02)

PREPARAÇÃO DE PEÇAS/ PARTS PREPARATION
PREPARACION DE PIEZAS

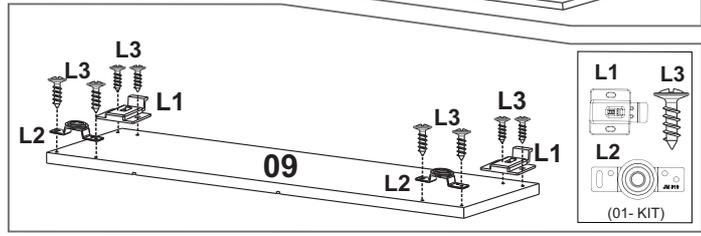
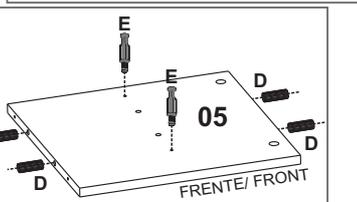
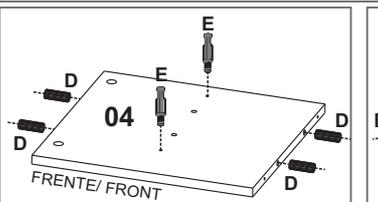
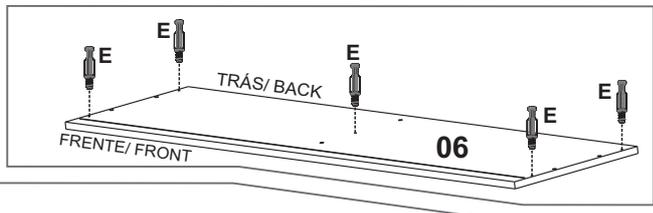
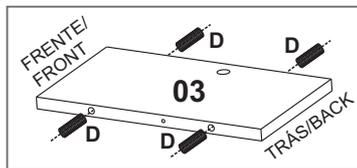
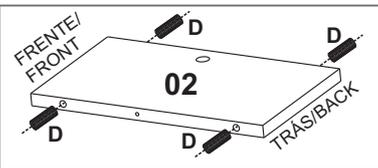
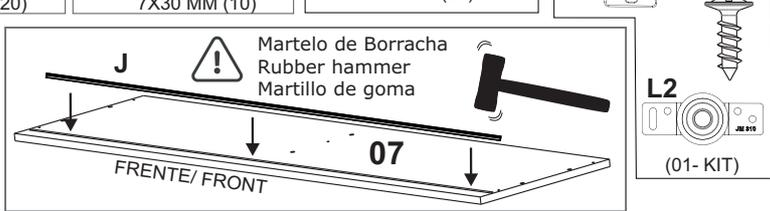
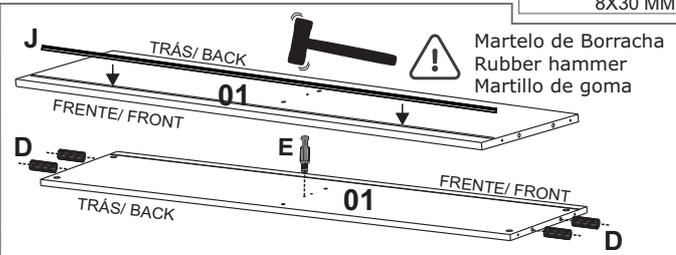
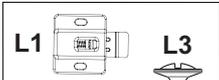
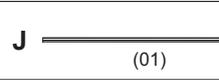
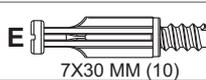
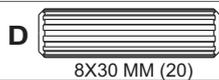

1 Obs: As peças pintadas nos passos são apenas ilustrativas.
 The parts painted in the steps are illustrative only.
 Las partes pintadas en los pasos son solo ilustrativas.

A=01

2

F=05
G=01

3

F=05
G=05

4

A=05

5

H=11
I=50

6

B=08
C=08
M=02

ATENÇÃO/ ATTENTION / ATENCION

7

REGULAR O PARAFUSO/ SCREWADJUSTMENT/ AJUSTE EL TORNILLO

ABAIXAR E ENCAIXAR/ LOWER THE DEVICE FOR IT TO FIT IN ABAJAR E AJUSTAR

K=04

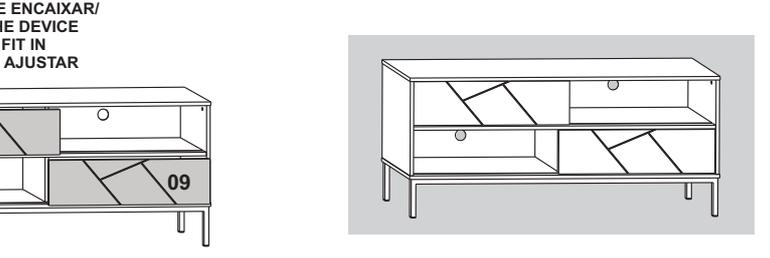

NOTA / NOTE
 Não nos responsabilizamos por acidentes, se a instalação do móvel não estiver com os procedimentos deste Manual e não for realizado por pessoa habilitada.
 We are not responsible for accidents if the installation of the furniture is not in accordance with the procedures in this Manual and is not carried out by a qualified person.
 No nos hacemos responsables de accidentes si la instalación de los muebles no se realiza de acuerdo con los procedimientos de este Manual y no es realizada por una persona calificada.